

TC

Modular clamping equipment

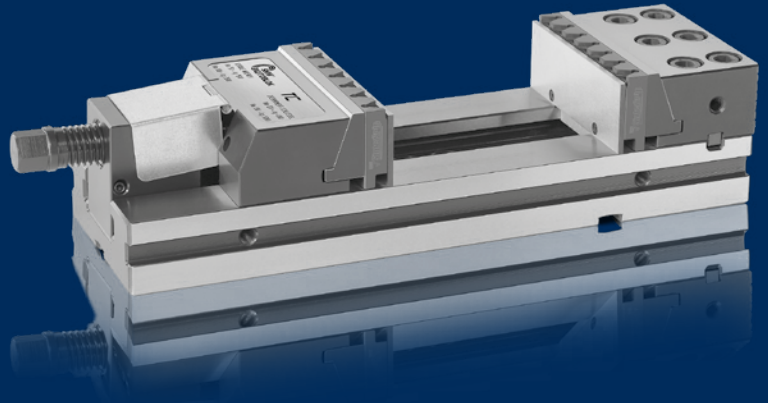

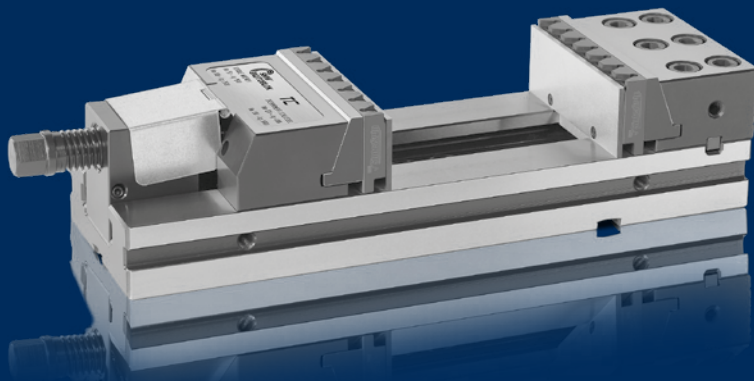

Modular clamping equipment

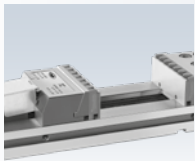

TC
Modular clamping equipment

Page 2.4

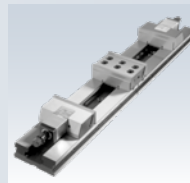

DCS-TCt
double clamping equipment

Page 2.11



TC & SinterGrip
The New Choice

Page 2.6



TC
Clamping modules

Page 2.14

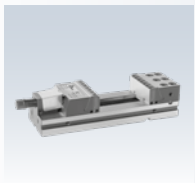

TCt
Clamping equipment for T-slots

Page 2.8

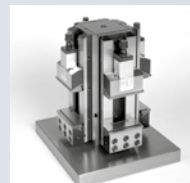

TC
Modular vertical clamping system

Page 2.18

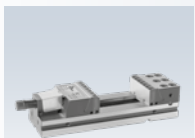

TCg
Clamping equipment for grid

Page 2.9



TC
Accessories for TC clamping equipment

Page 2.23



TCt-XL
Clamping equipment for T-slots

Page 2.10

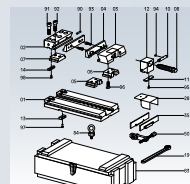

TC
Spare parts for TC clamping equipment

Page 2.27

TC

Modular clamping equipment

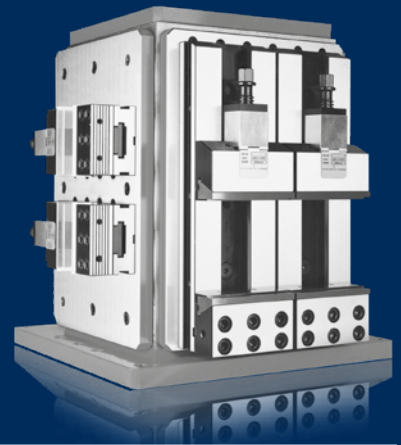

TC is ...

Modular

We use the true definition of the term modular; product which is composed of separate or separable elements. With these separate or separable elements we can achieve many different clamping solutions.

The only different component of these clamping solutions is the base.

The base length determines the clamping capacity while all other components remain the same.

Fixed and movable vise jaws can be used with any base configuration, offering the most flexible workholding solutions available.

This modular system allows the user to realize the maximum number of workholding combinations with the minimum investment in equipment.

Precision

All sliding and joining surfaces are precision ground.

Each item is thoroughly inspected and tested both before and after assembly.

This rigid quality control allows us to offer the high tolerance levels shown on page 47.

Alignment of the clamping equipment is ensured by using high tolerance ground keys.

Other key dimensions are available upon request.

The clamping jaws pull the workpiece down 0.2 mm. (0.008") against the ground base for unmatched accuracy.

Durability

All components are constructed from oversize steel profiles ensuring the equipment is exceptionally sturdy and can provide the user with optimal performance.

Wear parts are special treated to achieve a surface hardness of 50/60 HRC.

All non-ground surfaces are burnished to protect against corrosion.

Quick-change

A patented system allows quick repositioning of the clamping jaws.

The clamping jaw is lifted slightly from the base and shuttled to the next clamping position then lowered into place.

Part changeovers and size changes can be made quickly and easily.

Reliable

The six bolts mounting the fixed jaw to the base provide the most rigid platform possible to support the clamped workpiece.

Versatility

The fixed jaw has serrations on the rare face so that by reversing it, unmachined workpieces can be clamped.

The movable jaw can be rigid or floating (for clamping on uneven surfaces).

The interchangeability of the rigid slide-way with the floating slide-way (both included as standard equipment) allows the user to clamp finished or raw workpieces.

The standard CLAK system allows the quick-change of parallels, angular parallels, soft jaws and "V" jaws in order to machine any workpiece.

Manageable

The weight of 27 kg (59 lb.) for the 150 mm. x 200 mm. (6"x 8") vise and simple clamping system allow for easy movement from one machine tool to another.

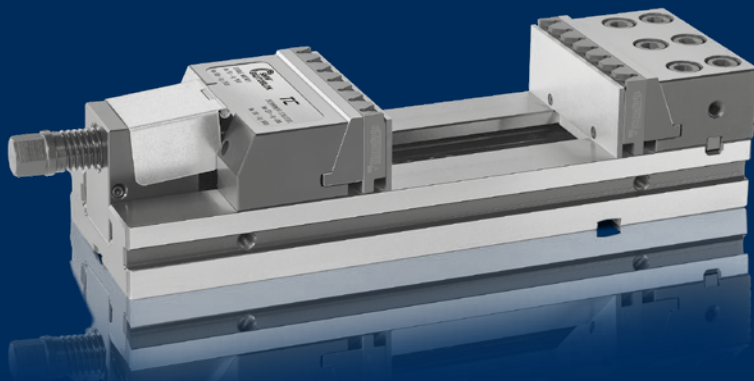

The advantages of modularity

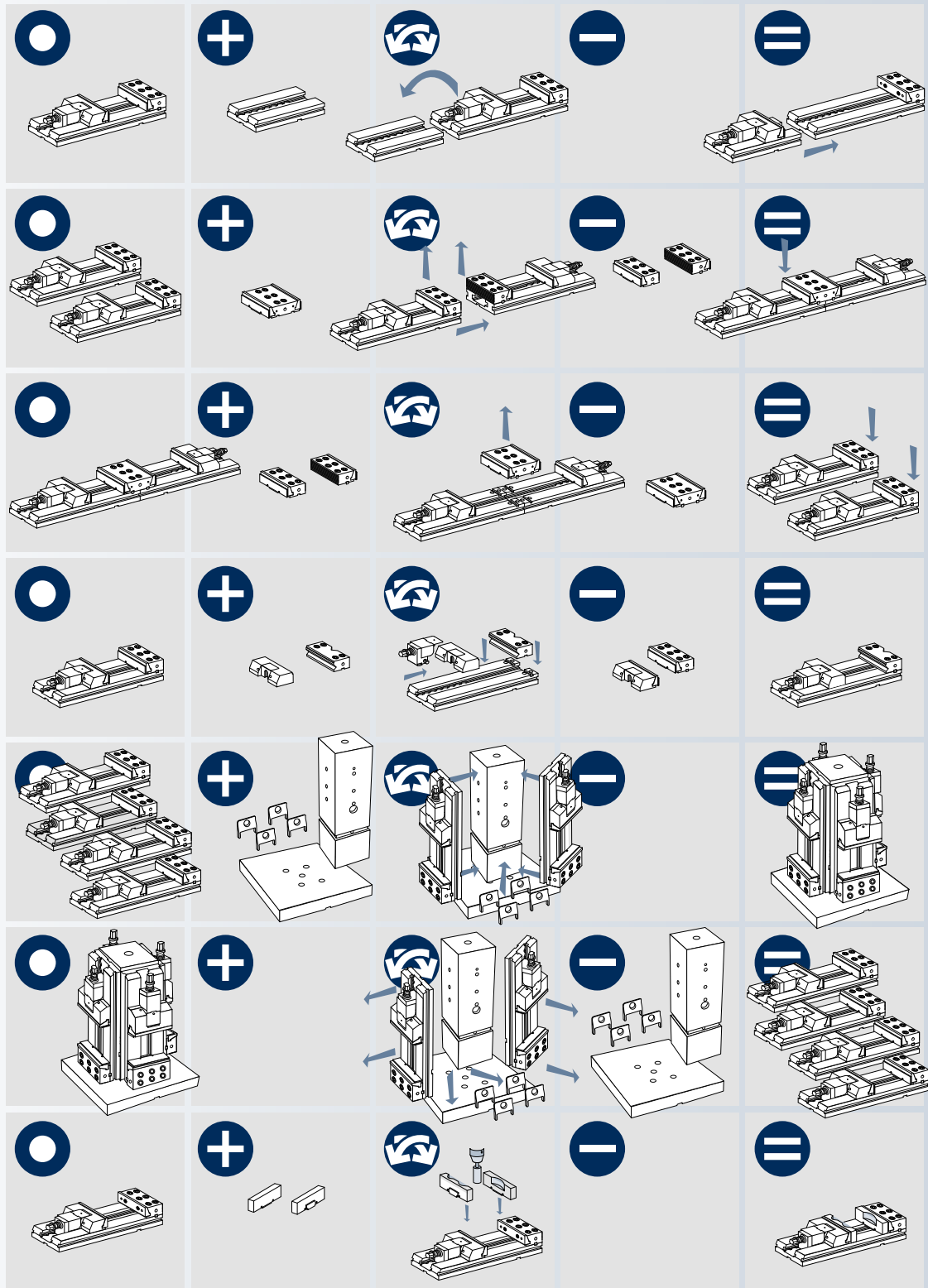

● Start

⊕ Add

↻ Combine

⊖ Remove

= Result

TC

Modular clamping equipment

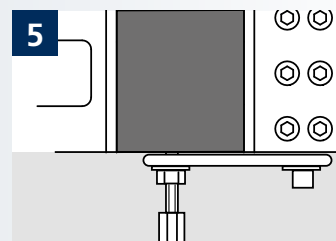
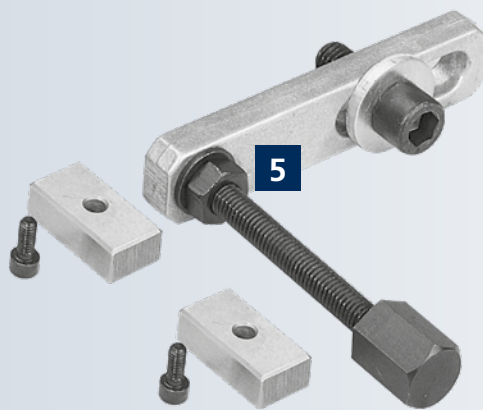

Work stop

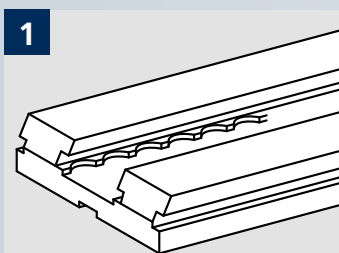

Patented system for quick positioning

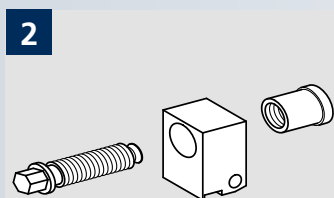

Block for clamping screw with threaded anti-friction bronze bushing

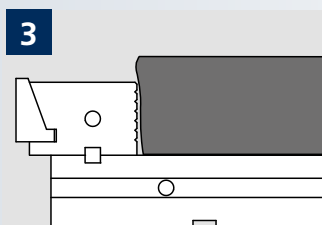

Fixed support turned of 180° (grooved part)

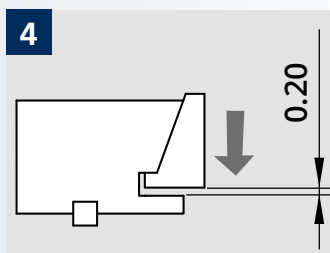

Pull down jaws

Modular clamping equipment

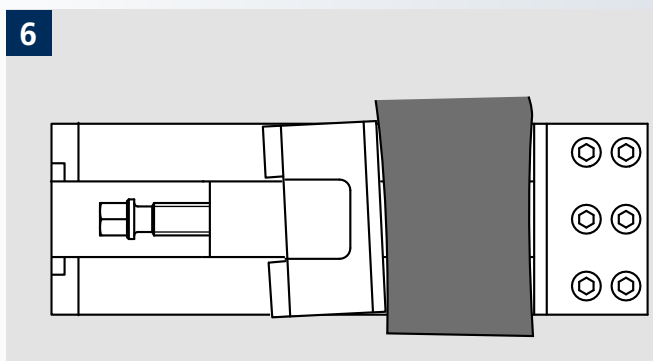
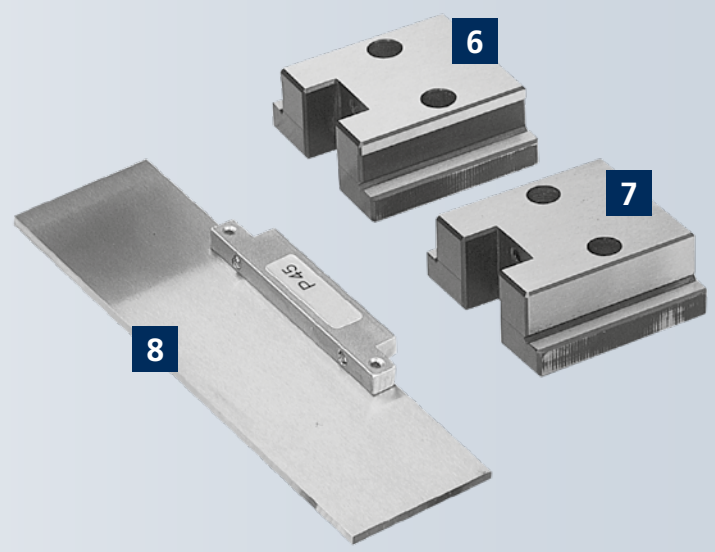
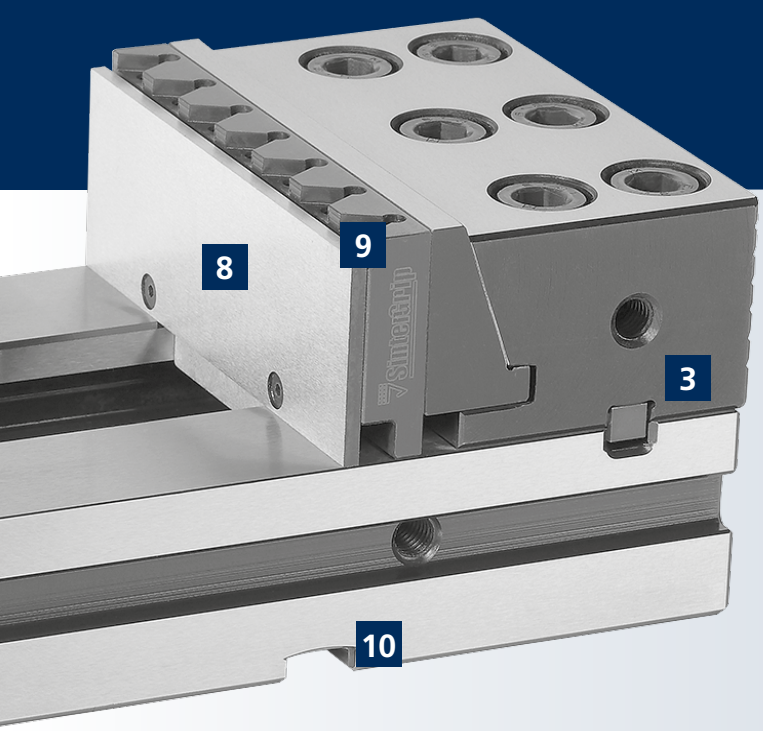

Floating slide - way raw workpieces

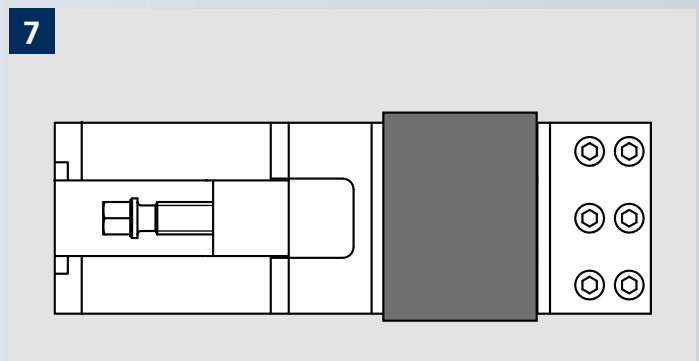

Rigid slide-way for finished workpieces

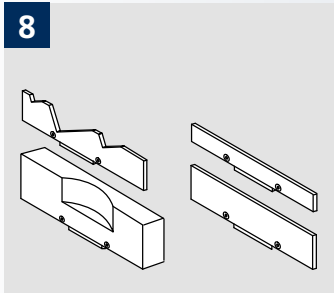

Parallels, Angulars parallels, soft jaws quick change



Jaws for SinterGrip inserts

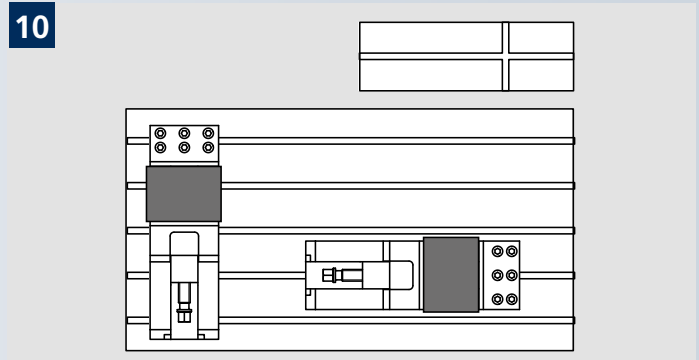

Cross key for T-slots M.T.

Our new patented product **SinterGrip** is born to satisfy the current need to clamp a workpiece for very few millimeters (with SinterGrip 3,5 mm clamping surface), and this for the following reasons:

- 1) In order to machine the workpiece completely in a single operation (especially for 5 axis machines);
- 2) In order to save money for the raw materials, especially when they have a big impact on the price (aluminum, titanium, etc.)

Indirectly to these reasons, and in order to improve the performance of the machine tool and the tools

**higher cutting speed + higher feed rate =
bigger volume of metal removed =
less time to machine the workpiece**

the market requires safe clamping, which could at the same time possibly avoid the deformations of the piece itself.

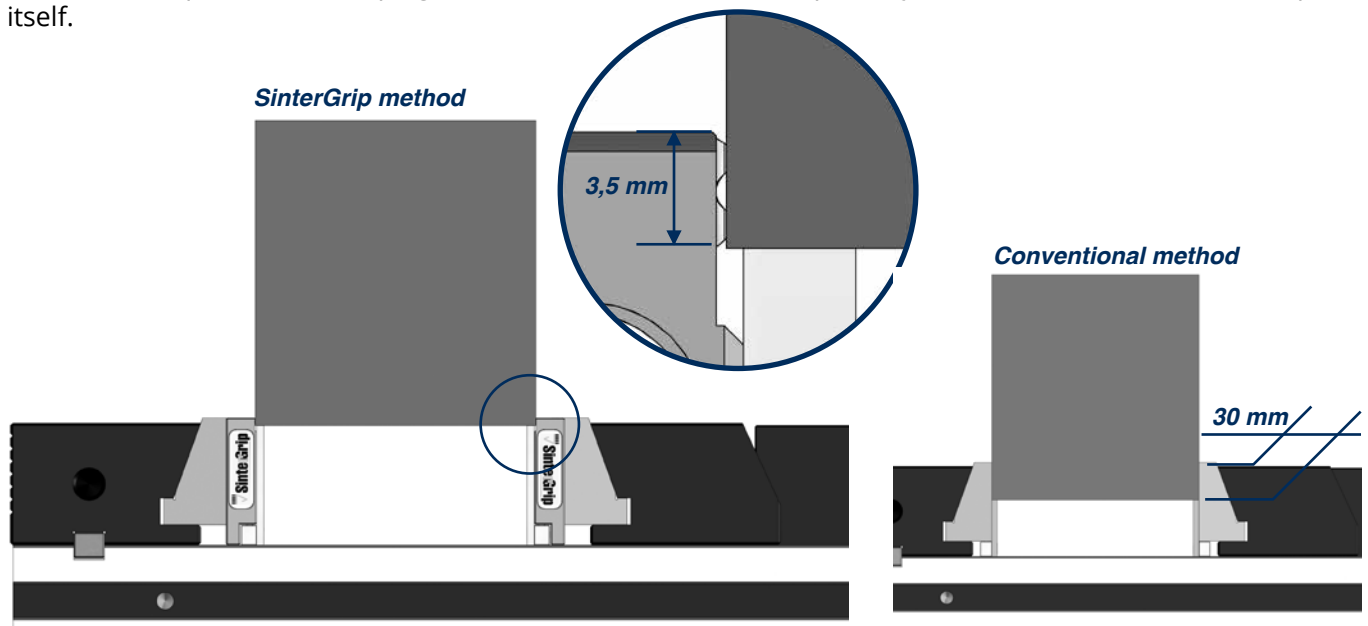

Only 3,5 mm clamping surface, no need of pre-machining the workpiece, clamping stability, higher cutting rate: **SinterGrip** brings only advantages compared to the traditional systems.

On the contrary, traditional systems need, for the clamping of the workpiece, a bigger clamping surface, with the result of waste of raw materials and greater possibility of deformation of the workpiece.

Working example: jaws mounted on a TC Vise



Working example: with inserts SinterGrip mounted.



The company policy from OML has always been to seek the best solution for the customer, developing and updating all our products with the latest technologies available.

In this sense, the modular vises of the TC series will now be supplied with: pair of jaws without tungsten carbide coating, 1 pair of parallels, 1 T9 TORX wrench and 1 kit of 10 screws, which allow to assemble the latest products **SinterGrip** also on this series.

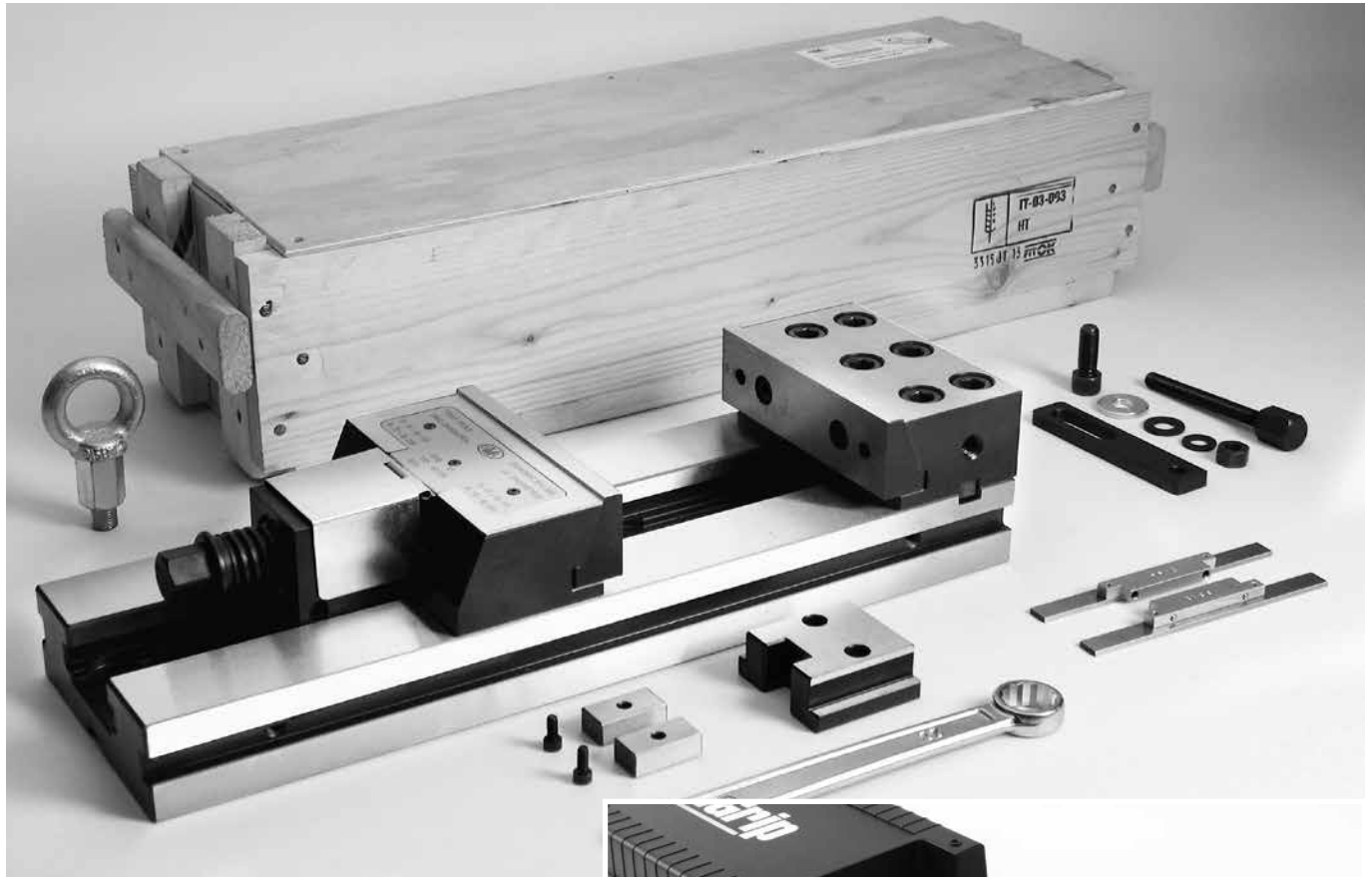

Working example:
jaws mounted on a TC vise.
SinterGrip inserts are not included:
ask to your local dealer.



Working example: mounting of the jaws.



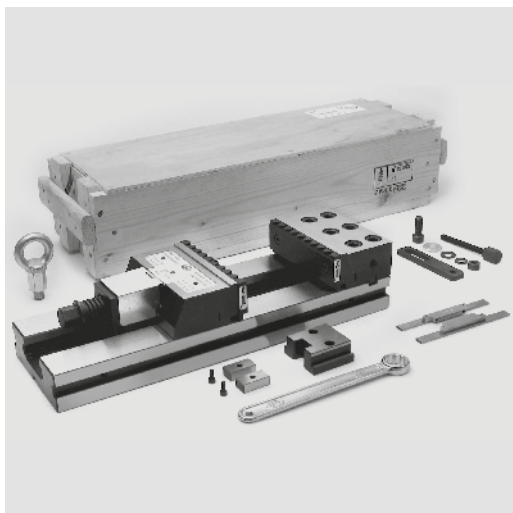

Clamping equipment **TcT** complete with wrench, work stop, rigid slide way, floating slide-way (for raw workpiece), pair of positioning keys, pair of SinterGrip jaws (inserts not included), pair of **CLAK** parallels, cover for the protection of the screw, eye bolt for lifting, wooden packing case.

NOTE: SinterGrip jaws see page S.15

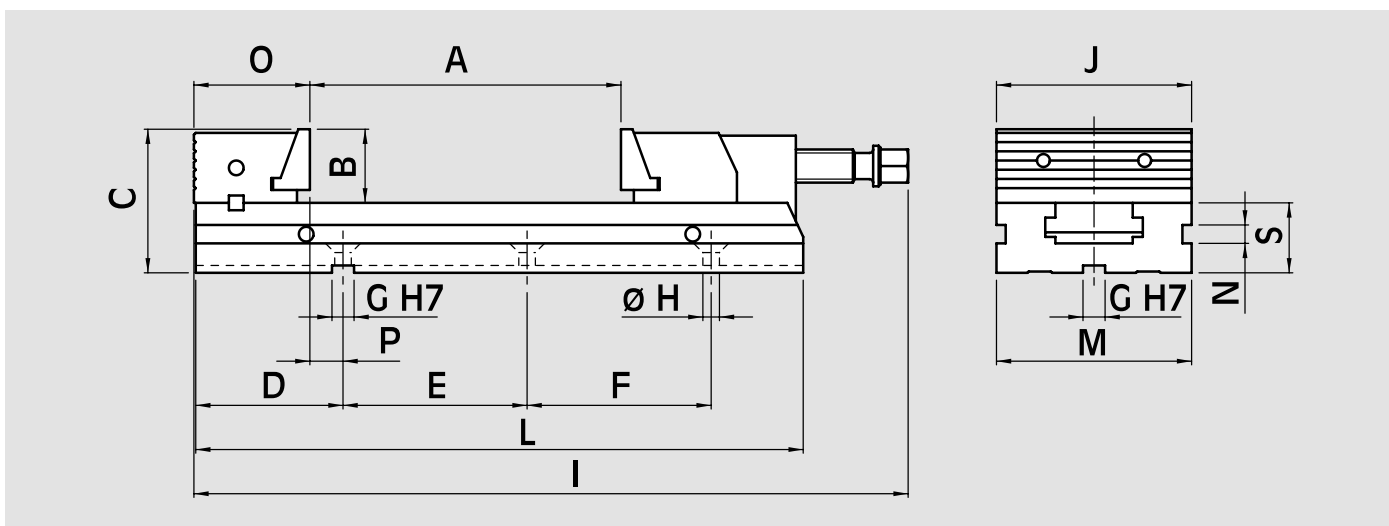

Type	Id. No.	A mm	B mm	C mm	D mm	E mm	F mm	G mm	H mm	I mm	J mm	L mm	M mm	N mm	O mm	P mm	S mm	Weight kg
TCt 110x100	77580101	100	40	78	80	150	-	12	9	338	110	280	110	10	63	18	38	11.5
TCt 110x150	77580102	150	40	78	80	100	100	12	9	388	110	330	110	10	63	18	38	12.5
TCt 150x200	77580201	200	50	98	114	200	-	18	12.5	481	150	413	150	13	85	30	48	27
TCt 150x250	77580202	250	50	98	114	100	150	18	12.5	531	150	463	150	13	85	30	48	29
TCt 150x300	77580203	300	50	98	114	100	100	18	12.5	588	150	520	150	13	85	30	48	31.5
TCt 200x300	77580302	300	70	138	149	200	200	18	12.5	697	200	610	200	15.5	123	27	68	78
TCt 200x400	77580303	400	70	138	149	150	150	18	12.5	797	200	710	200	15.5	123	27	68	86

Special executions on request.

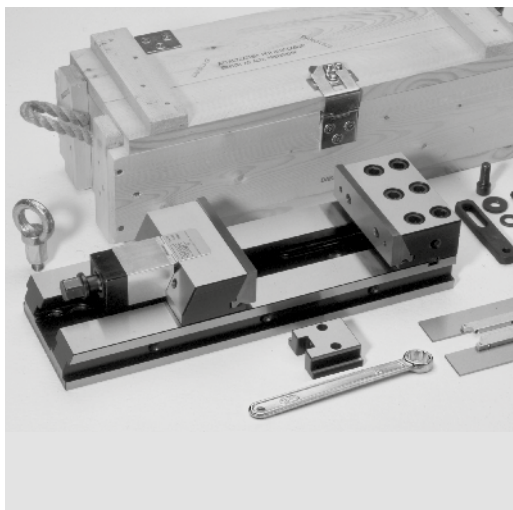

Clamping equipment **TCg** (machined for positioning holes mm16 H7*) complete with wrench, work stop, rigid slide way, floating slide-way (for raw workpiece), pair of SinterGrip jaws (inserts not included), pair of **CLAK** parallels, cover for the protection of the screw, eye bolt for lifting, wooden packing case.

* Other fixing and positioning holes dimensions upon request.
NOTE: SinterGrip jaws see page S.15

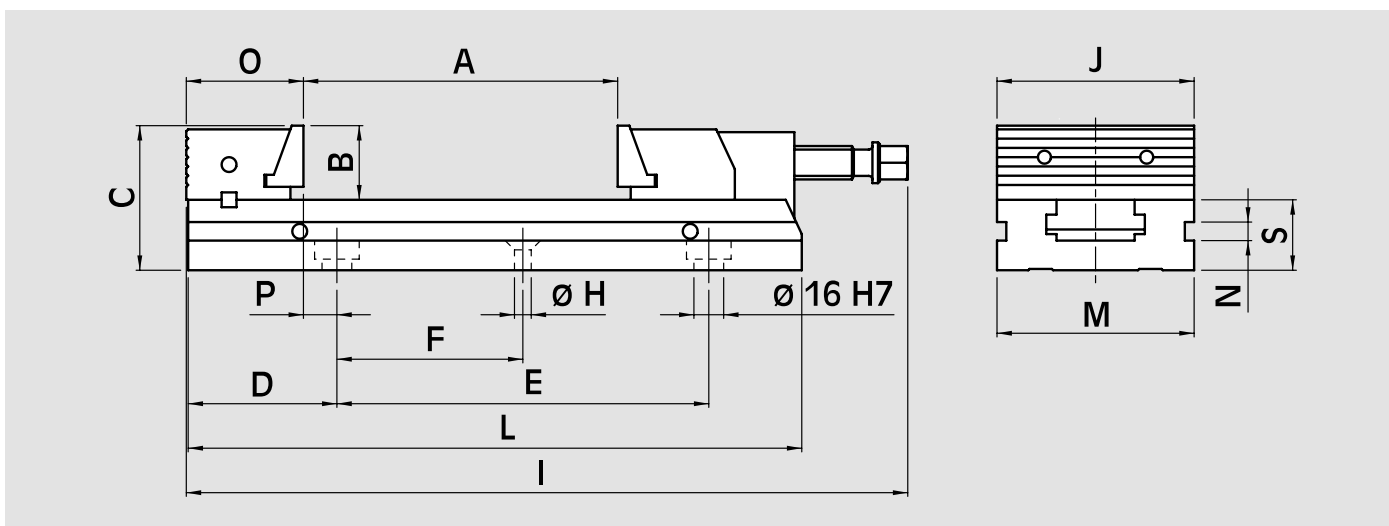

Type	Id. No.	A mm	B mm	C mm	D mm	E mm	F mm	H mm	I mm	J mm	L mm	M mm	N mm	O mm	P mm	S mm	Weight kg
TCg 110x100	77580107	100	40	78	80	150	-	9	338	110	280	110	10	63	18	38	11.5
TCg 110x150	77580108	150	40	78	80	200	-	9	388	110	330	110	10	63	18	38	12.5
TCg 150x200	77580207	200	50	98	114	200	-	12.5	481	150	413	150	13	85	30	48	27
TCg 150x250	77580208	250	50	98	114	200	-	12.5	531	150	463	150	13	85	30	48	29
TCg 150x300	77580209	300	50	98	114	200	-	12.5	588	150	520	150	13	85	30	48	31,5
TCg 200x300	77580308	300	70	138	149	400	200	12.5	697	200	610	200	15.5	123	27	68	78

TCT-XL

Clamping equipment for T-slots

- Quick positioning for the jaw
- Extra long clamping range



Clamping equipment **TCT-XL**, complete with wrench, work stop, rigid slide-way, floating slide-way (for raw workpiece), pair of positioning keys, pair of **CLAK** parallels, cover for the protection of the screw, eye bolt for lifting, wooden packing case.

NOTE: SinterGrip jaws see page S.15

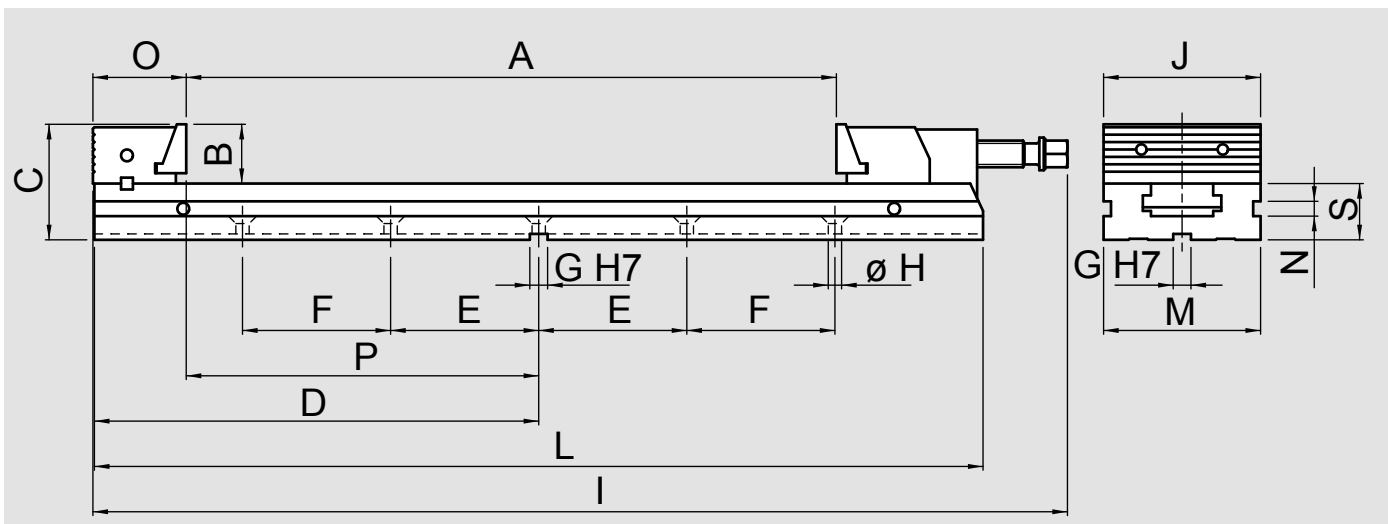

Type	Id. No.	A mm	B mm	C mm	D mm	E mm	F mm	G mm	H mm	I mm	J mm	L mm	M mm	N mm	O mm	P mm	S mm	Weight kg
TCT-XL 110x425	77580104	425	40	78	300	100	100	12	9	658	110	600	110	10	63	238	38	18.2
TCT-XL 150x545	77580204	545	50	98	379	100	150	18	12.5	825	150	758	150	13	85	298	48	40.0
TCT-XL 150x665	77580205	665	50	98	439	100	200	18	12.5	946	150	878	150	13	85	355	48	44.7

- Quick positioning for the jaw
- Double clamping system

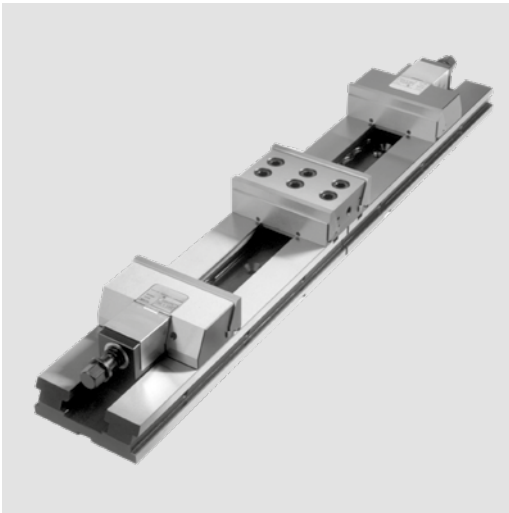

Double clamping equipment DCS-TCt complete with:

- 1 wrench,
- 2 work stops,
- 2 rigid slide-ways,
- 2 floating slide-ways (for raw workpiece),
- 1 pair of positioning keys,
- 2 pair of CLAK parallels,
- 2 covers for the protection of the screw,
- 2 eye bolts for lifting,
- wooden packing case.

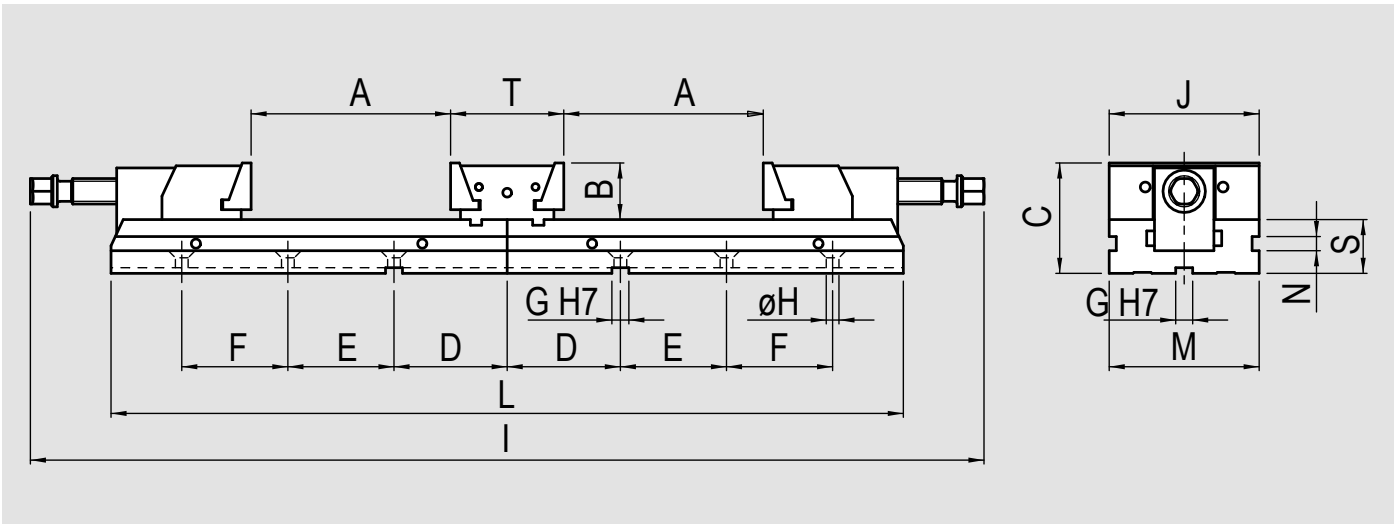

Type	Id. No.	A mm	B mm	C mm	D mm	E mm	F mm	G mm	H mm	I mm	J mm	L mm	M mm	N mm	S mm	T mm	Weight kg
DCS-TCt 110x130	77581101	130	40	78	80	150	-	12	9	676	110	56	110	10	38	80	22
DCS-TCt 110x180	77581102	180	40	78	80	100	100	12	9	776	110	660	110	38	80	24	24
DCS-TCt 150x230	77581201	230	50	98	116	200	-	18	12.5	966	150	830	150	13	48	108	52
DCS-TCt 150x280	77581202	280	50	98	116	100	150	18	12.5	1066	150	930	150	13	48	108	56
DCS-TCt 200x330	77581302	330	70	138	150	200	200	18	12.5	1394	200	1222	200	15.5	68	194	144

Working example

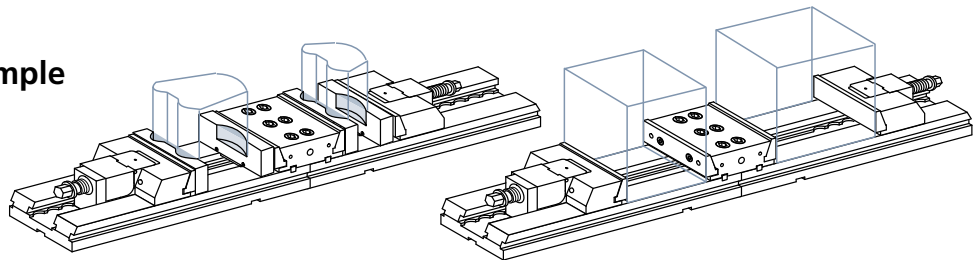

The modularity of the system combined with some other components offers many additional clamping solutions.

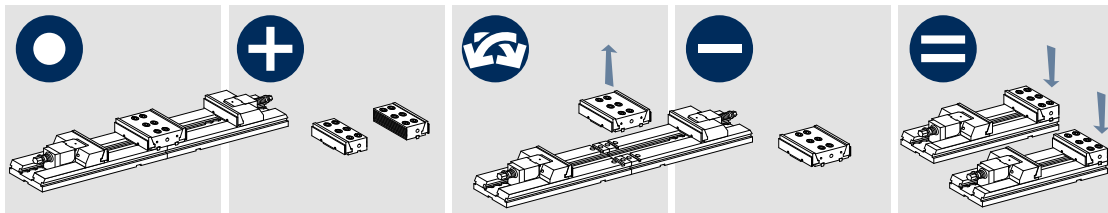

Clamping the workpiece

For controlled clamping and the best repetibility use of a torque wrench is recommended:

- 1 clamp the workpiece with the torque wrench at the necessary clamping force in accordance with the following diagram
- 2 Zero set on the workpiece
- 3 Machine the first workpiece
- 4 Clamp the other workpieces at the same clamping force

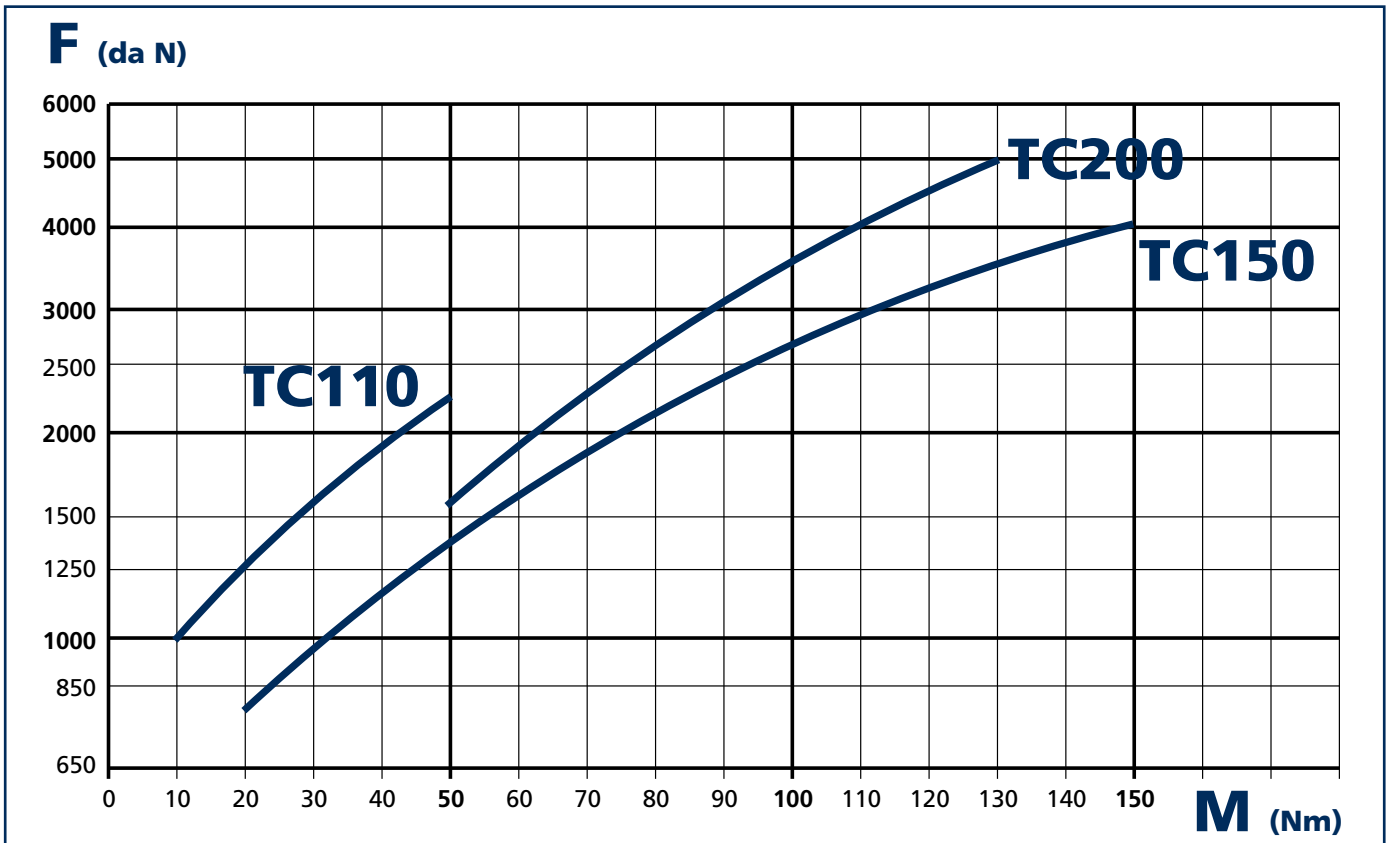

Jaw alignment

When it is necessary to replace the jaws in order to ensure the best part pull-down, we recommended the following steps:

1) make sure the jaws are properly secured to the support.

2) loosen the adjustment screws until the jaws are backed off about 0.2 mm. (0.008") tighten the lock nuts located on the back side of the support in the opposite direction of the adjustment screws

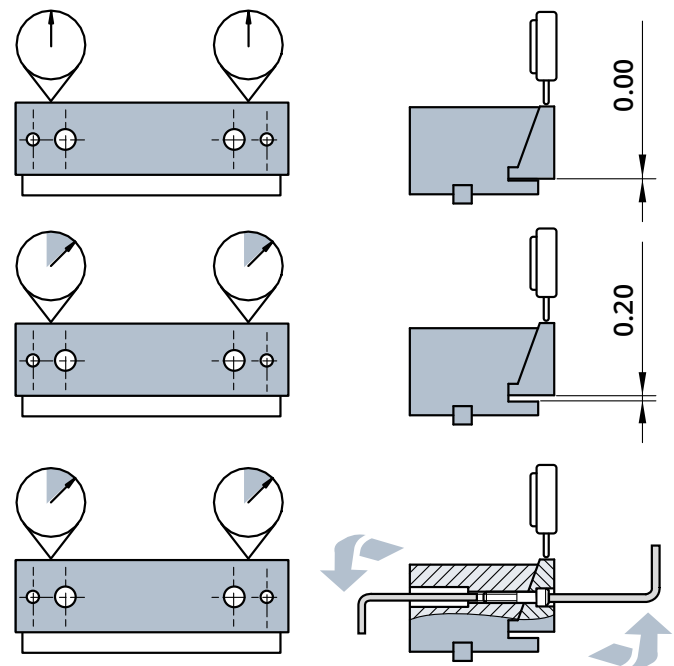

How to clamp the vises at the table of the machine tool.

In order to obtain a perfect clamping of the workpiece and in order to obtain the tolerances of which point " E " is necessary to clamp the vise on the table of the machine tool by means of the ORIGINAL OML'S CLAMPS (Ex cod. 58022795 see drawing n. 1).

Or by means of the T-nuts (58022595 see drawing n. 2)

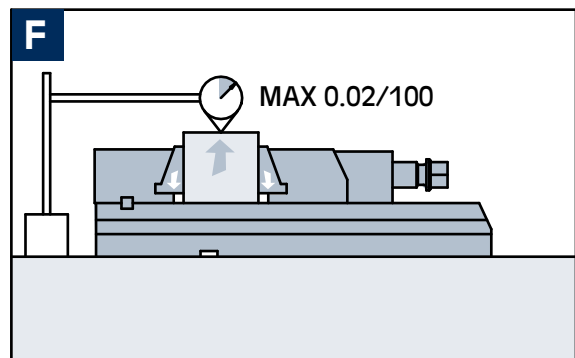
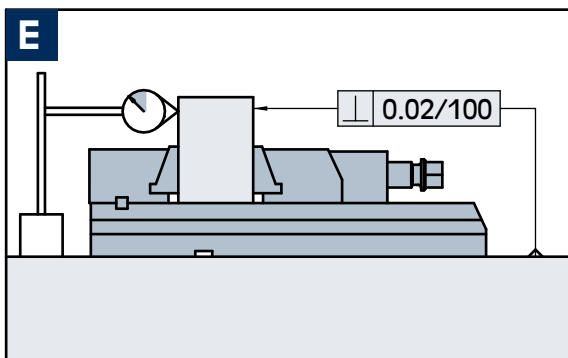
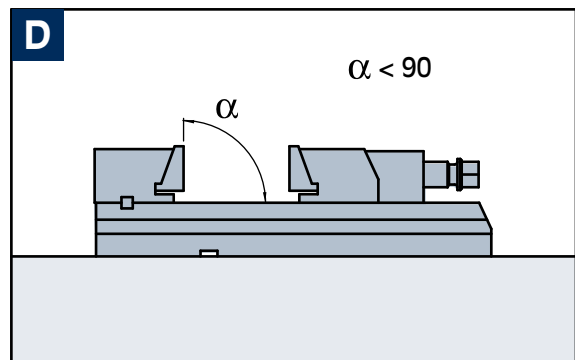
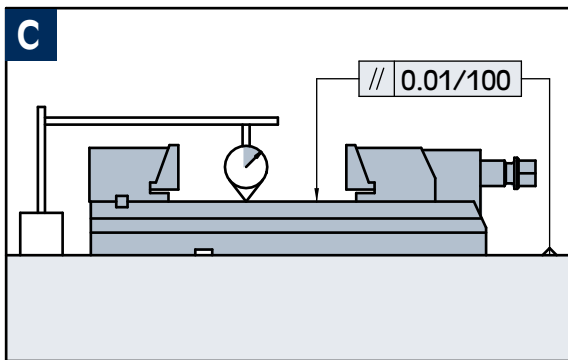
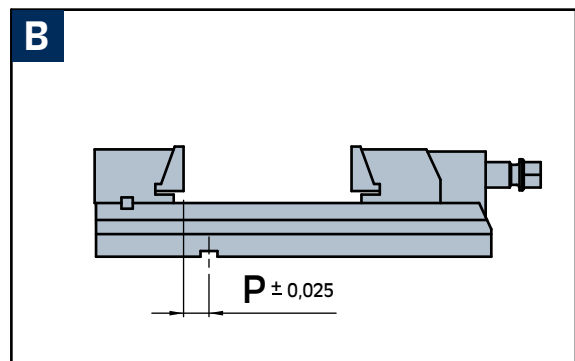
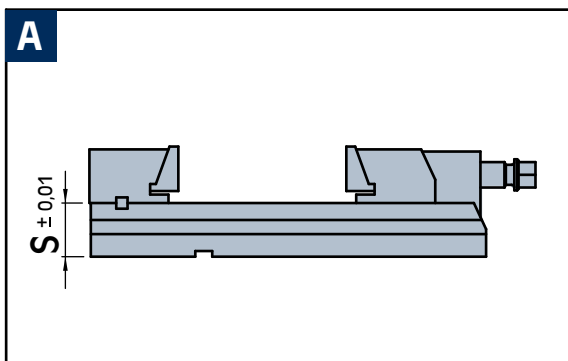
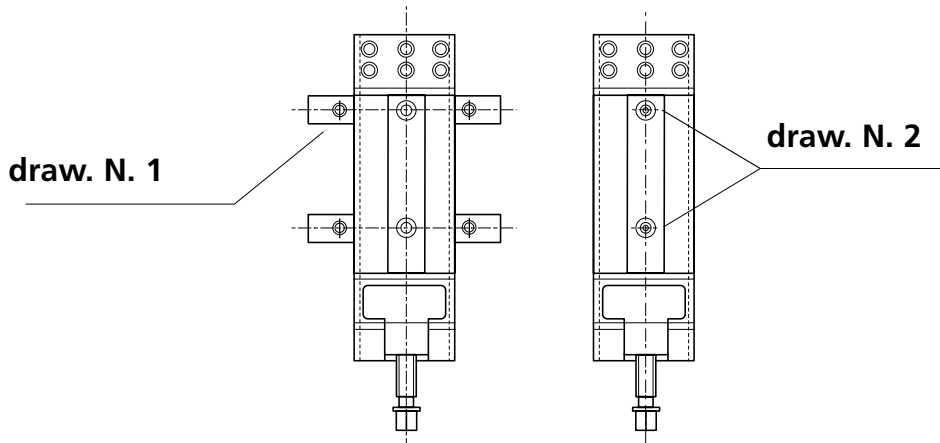

Tct extension element with pair of positioning keys

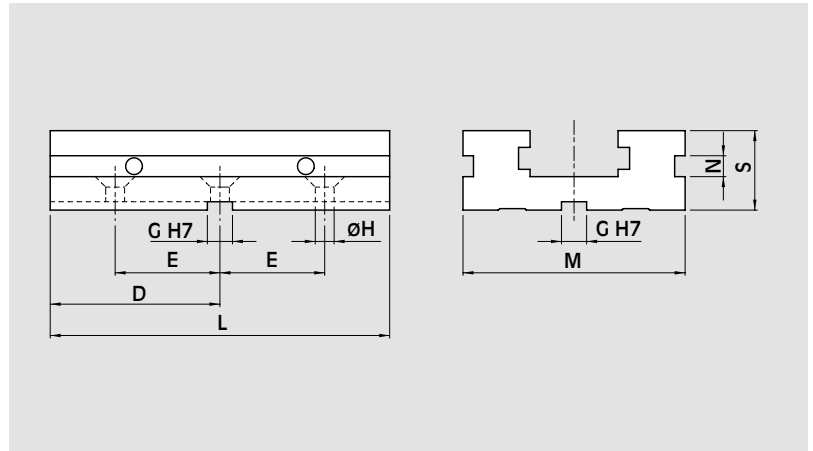

Id. No.	for type	D mm	E mm	G mm	H mm	L mm	M mm	N mm	S mm	Weight kg
58 01 17 00	Tct 110 x ...	81	50	12	9	162	110	10	38	3,5
58 02 17 00	Tct 150 x ...	114	75	18	12,5	228	150	13	48	9
58 03 17 00	Tct 200 x ...	150	100	18	12,5	300	200	15,5	68	22

Working example

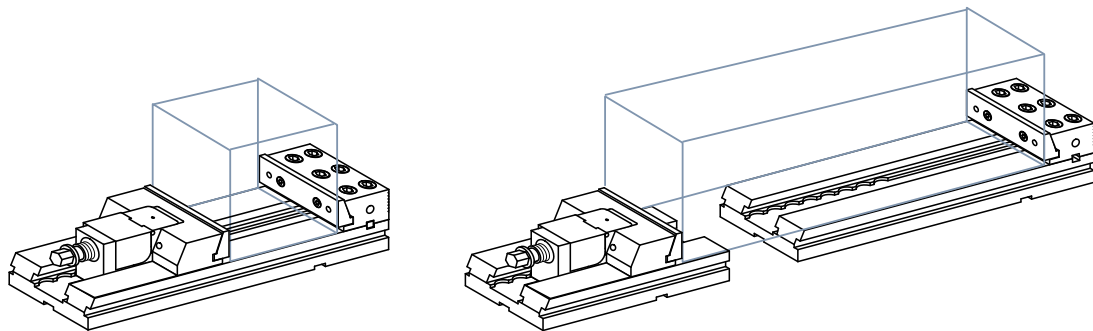

The modularity of the system combined with some other components offers many additional clamping solutions.

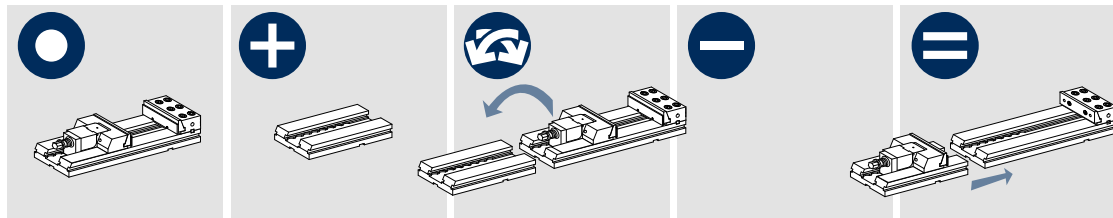

TC double fixed support with jaw

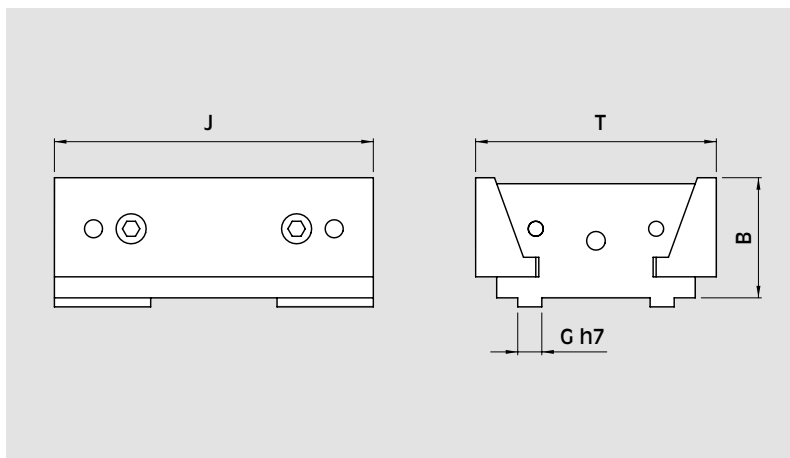

Id. No.	for type	B mm	G mm	J mm	T mm	Weight kg
58 11 72 10	TC 110 x ...	40	8	110	80	2,2
58 12 72 10	TC 150 x ...	50	12	150	108	5
58 13 72 10	TC 200 x ...	70	14	200	194	11,6

Tct complete extension element

with pair of positioning keys h6 (by choice)

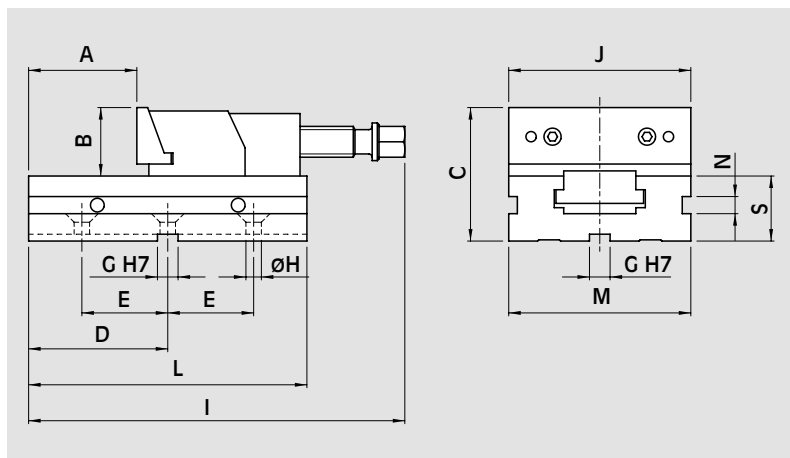
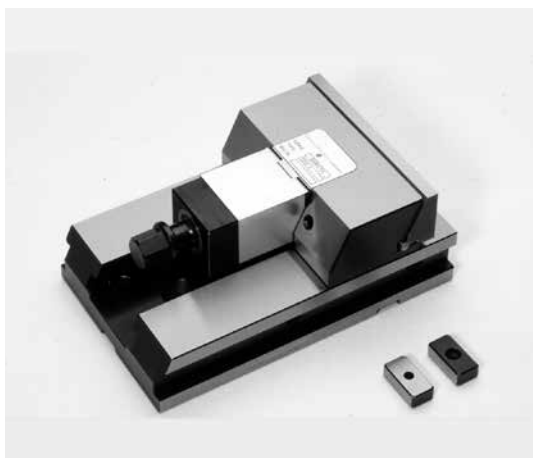

Id. No.	for type	A mm	B mm	C mm	D mm	E mm	G mm	H mm	I mm	J mm	L mm	M mm	N mm	S mm	Weight kg
58 01 71 10	Tct 110 x ...	60	40	78	81	50	12	9	220	110	162	110	10	38	6,2
58 02 71 10	Tct 150 x ...	100	50	98	114	75	18	12,5	295	150	228	150	13	48	15,1
58 03 71 10	Tct 200 x ...	120	70	138	150	100	18	12,5	390	200	300	200	15,5	68	39,2

TC base with fixed support with jaw

complete with pair of positioning keys h6 (by choice)

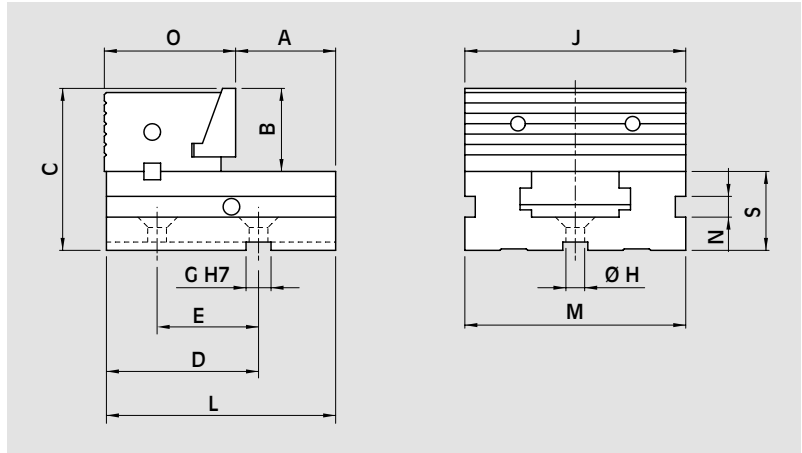

Id. No.	for type	A mm	B mm	C mm	D mm	E mm	G mm	H mm	J mm	L mm	M mm	N mm	O mm	S mm	Weight kg
58 01 70 10	TcT 110	58	40	78	80	50	12	9	110	120	110	10	63	38	4
58 02 70 10	TcT 150	81	50	98	114	75	18	12,5	150	165	150	13	85	48	9
58 03 70 10	TcT 200	82	70	138	149	100	18	12,5	200	205	200	15,5	123	68	28

TC base with double fixed support with jaw

complete with pair of positioning keys h6 (by choice)

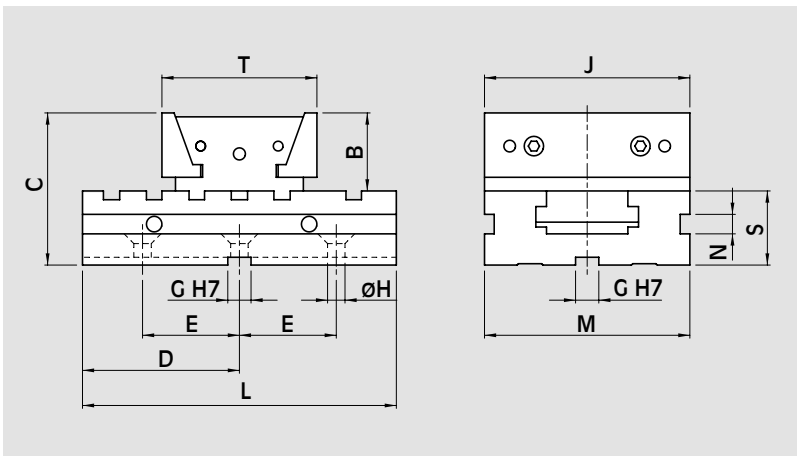
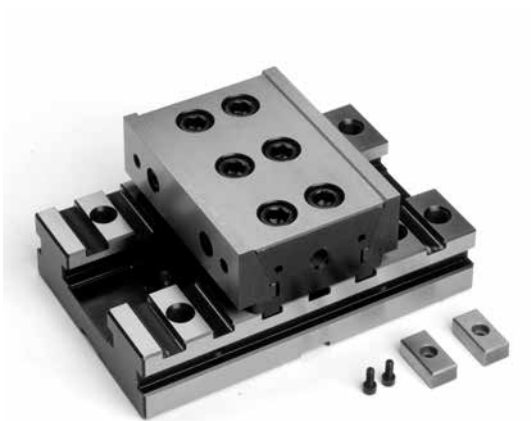

Id. No.	for type	B mm	C mm	D mm	E mm	G mm	H mm	J mm	L mm	M mm	N mm	S mm	T mm	Weight kg
58 11 70 10	TcT 110 x ...	40	78	81	50	12	9	110	162	110	10	38	80	5,6
58 12 70 10	TcT 150 x ...	50	98	114	75	18	12,5	150	228	150	13	48	108	13,5
58 13 70 10	TcT 200 x ...	70	138	150	100	18	12,5	200	300	200	15,5	68	194	34,7

Examples

Number of pieces
Code number

1 58 01 70 10

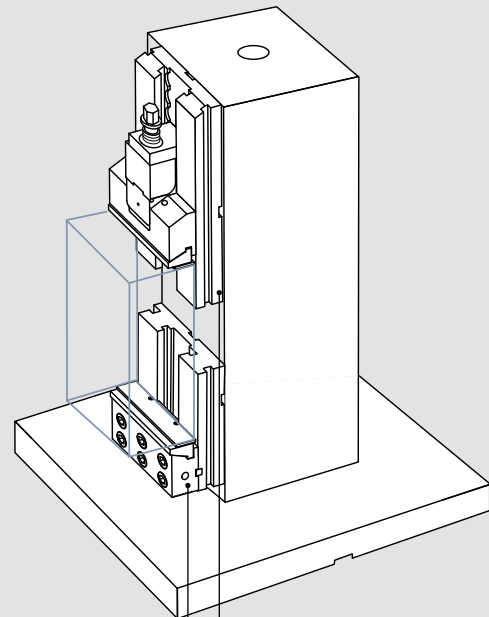
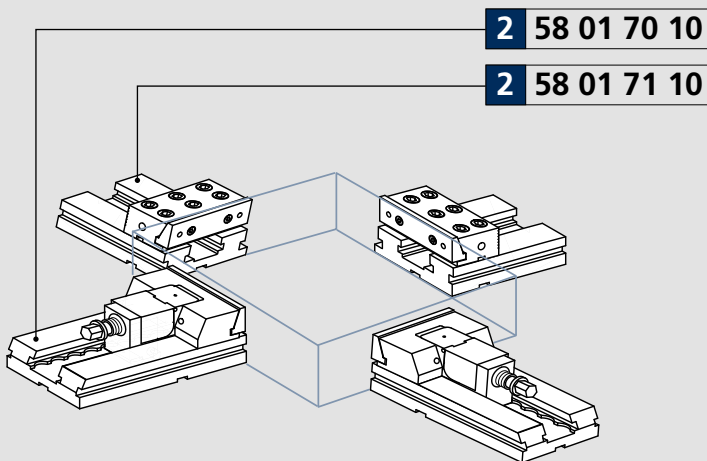
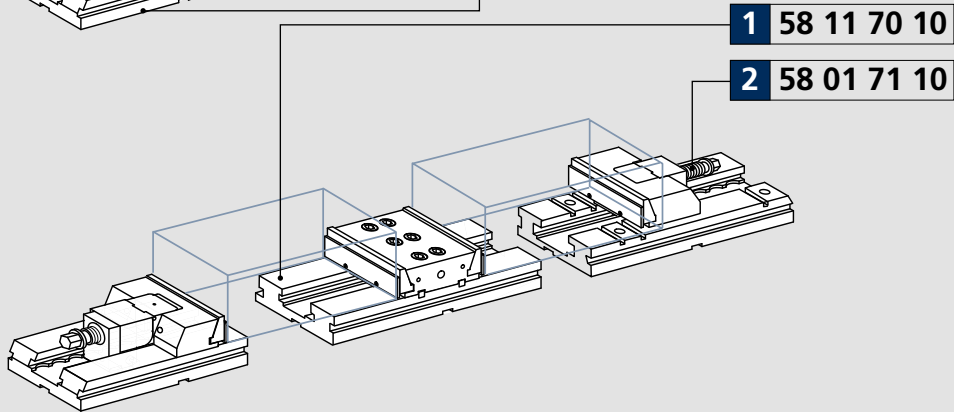
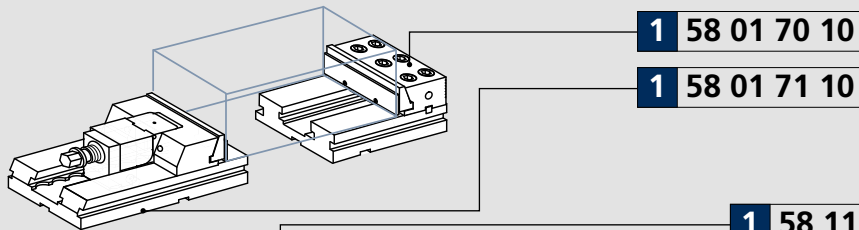

1 58 01 71 10

1 58 01 70 10

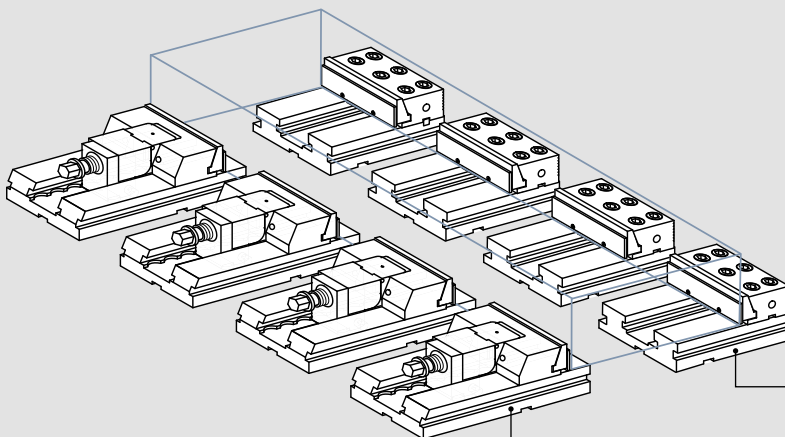

Vertical clamping system complete with:

4 clamping equipment TCt

1 column

1 base for vertical system TCt

4 pair of CLAK parallels

4 covers for protection of the screws

4 rigid slide-ways

4 floating slide-ways (for raw workpieces)

4 work stops

4 wrenches

eye bolt for lifting,

wooden packing case

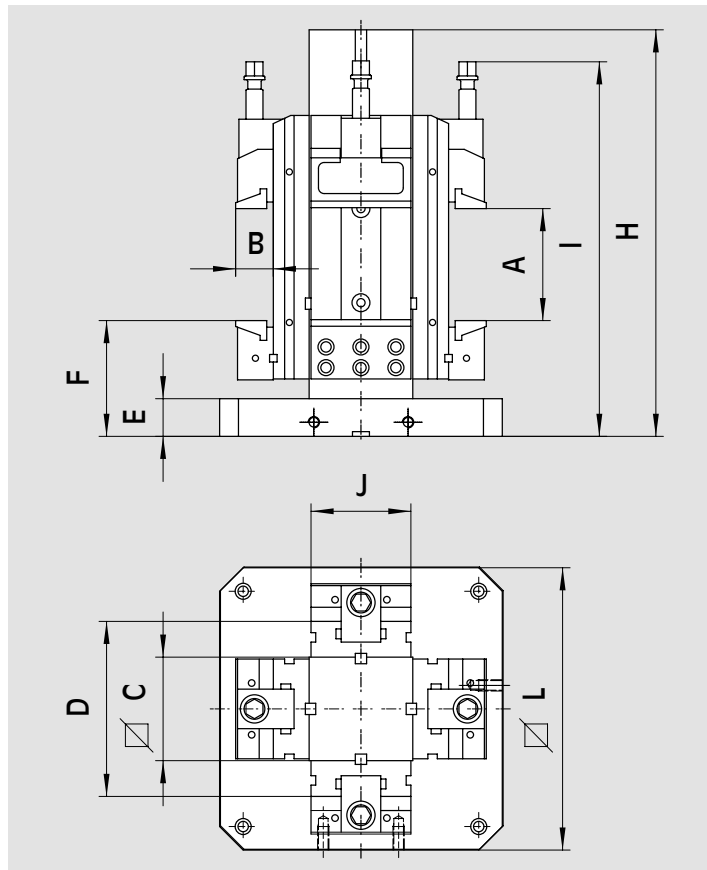

Id. No.	for type	A mm	B mm	C mm	D mm	E mm	F mm	H mm	I mm	J mm	L mm	Weight kg
77 58 21 11	TcT 110 x 100	100	40	110	186	40	123	391	400	110	300	108
77 58 21 12	TcT 110 x 150	150	40	110	186	40	123	391	450	110	300	112
77 58 22 21	TcT 150 x 200	200	50	150	246	40	151	580	550	150	400	255
77 58 22 22	TcT 150 x 250	250	50	150	246	40	151	580	600	150	400	263
77 58 22 23	TcT 150 x 300	300	50	150	246	40	151	580	655	150	400	273
77 58 22 31	TcT 150 x 200	200	50	150	246	40	151	580	550	150	500	282
77 58 22 32	TcT 150 x 250	250	50	150	246	40	151	580	600	150	500	290
77 58 22 33	TcT 150 x 300	300	50	150	246	40	151	580	655	150	500	300
77 58 23 32	TcT 200 x 300	300	70	200	336	40	173	661	750	200	500	580

The modularity of the system combined with same other components offers many additional clamping solutions.

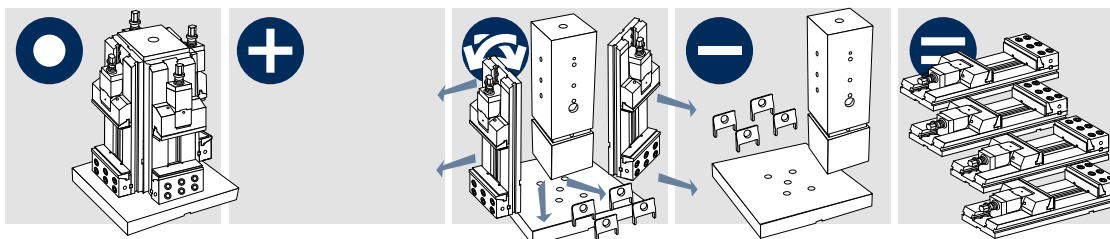

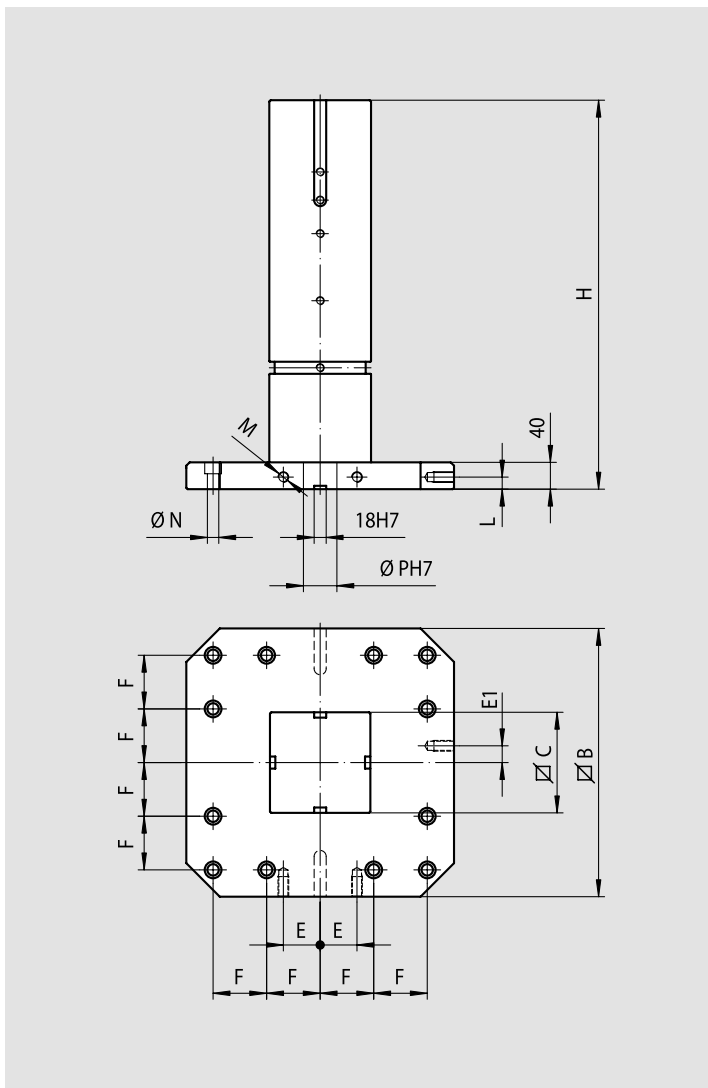

Id. No.	for type	B mm	C mm	E mm	E1 mm	F mm	H mm	L mm	M mm	N mm	P mm	Weight kg
58 21 80 10	TC 110	300	110	40	0	125	391	15	12	13	25	57
58 22 80 20	TC 150	400	150	55	25	80	580	18	16	17	50	142
58 22 80 30	TC 150	500	150	75	25	100	580	18	16	17	50	169
58 23 80 30	TC 200	500	200	75	25	100	661	18	16	17	50	266

Insert for vertical use



Id. No.	for type
58 21 33 00	TC 110 x ...
58 22 33 00	TC 150 x ...
58 23 33 00	TC 200 x ...

Vertical clamping system complete with:

4 clamping equipment TCt

1 cross cube

4 pair of CLAK parallels

4 covers for protection of the screws

4 rigid slide-ways

4 floating slide-ways (for raw workpieces)

4 work stops

4 wrenches

eye bolt for lifting

wooden packing case

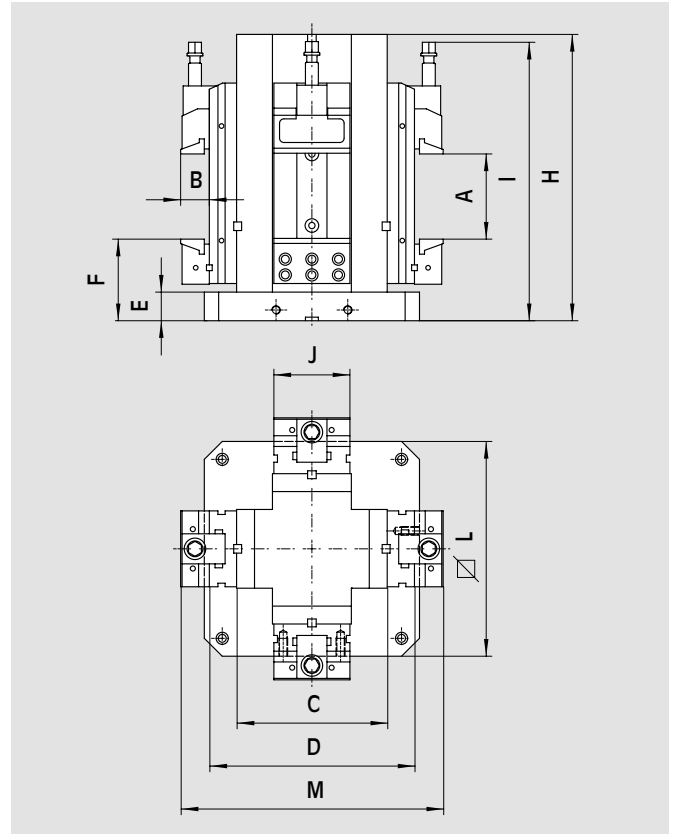
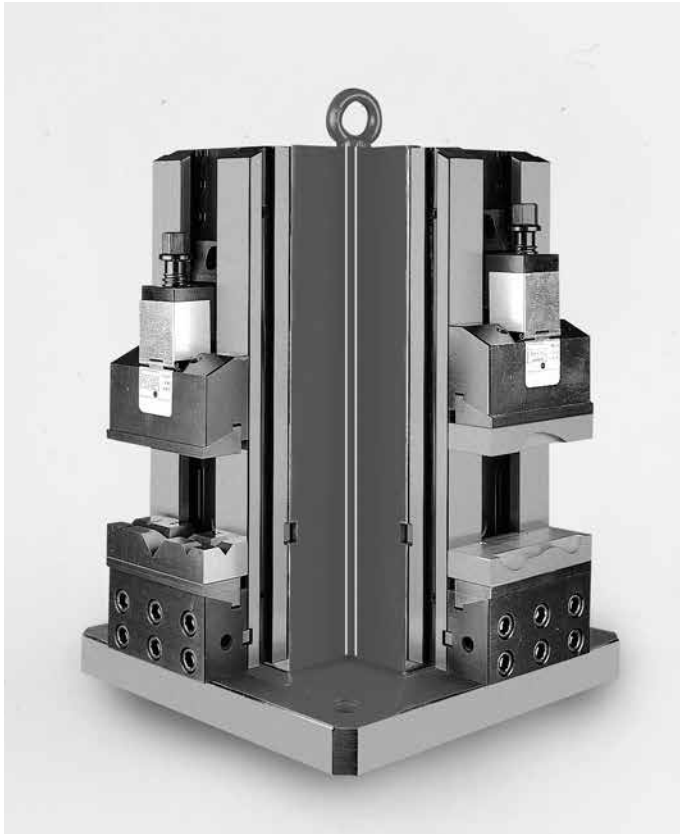

Id. No.	for type	A mm	B mm	C mm	D mm	E mm	F mm	H mm	I mm	J mm	L mm	M mm	Weight kg
77 58 51 11	TCt 110 x 100	100	40	210	286	40	114	382	390	110	300	366	121
77 58 51 12	TCt 110 x 150	150	40	210	286	40	114	382	440	110	300	366	125
77 58 52 21	TCt 150 x 200	200	50	300	396	40	145	580	545	150	400	496	320
77 58 52 22	TCt 150 x 250	250	50	300	396	40	145	580	595	150	400	496	328
77 58 52 23	TCt 150 x 300	300	50	300	396	40	145	580	652	150	400	496	338
77 58 52 31	TCt 150 x 200	200	50	300	396	40	145	580	545	150	500	496	348
77 58 52 32	TCt 150 x 250	250	50	300	396	40	145	580	595	150	500	496	356
77 58 52 33	TCt 150 x 300	300	50	300	396	40	145	580	652	150	500	496	366
77 58 53 42	TCt 200 x 300	300	70	350	486	45	182	670	760	200	630	626	675

Working example

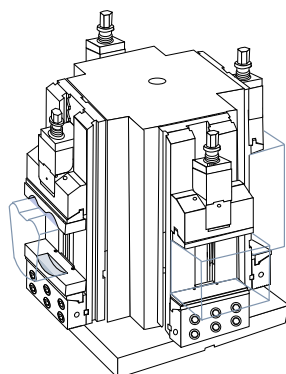

Vertical clamping system complete with:

- 4 double clamping equipment Tct
- 1 cross cube XL
- 8 pair of CLAK parallels
- 8 covers for protection of the screws
- 8 rigid slide-ways
- 8 floating slide-ways (for raw workpieces)

- 8 work stops
- 8 wrenches
- 8 inserts for vertical use
- eye bolt for lifting
- wooden packing case

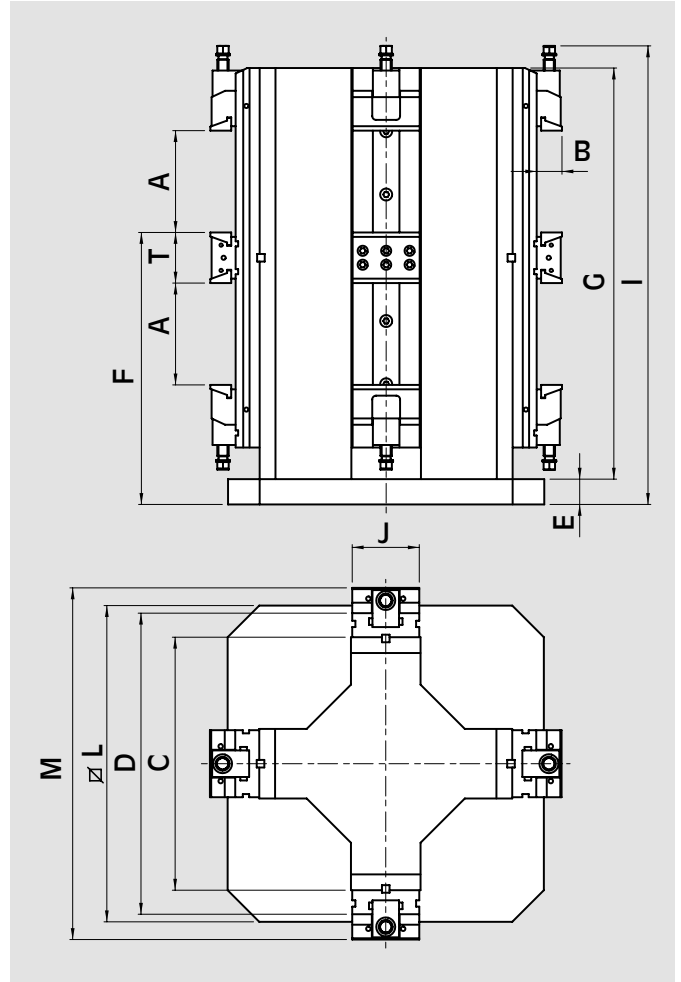

Id. No.	for type	A mm	B mm	C mm	D mm	E mm	F mm	G mm	I mm	J mm	L mm	M mm	T mm	Weight kg
77 58 61 01	DVCS-Tct 110 x 155	155	40	400	476	40	430	650	725	110	500	556	80	352
77 58 62 01	DVCS-Tct 150 x 195	195	50	550	646	45	515	795	890	150	630	746	108	647

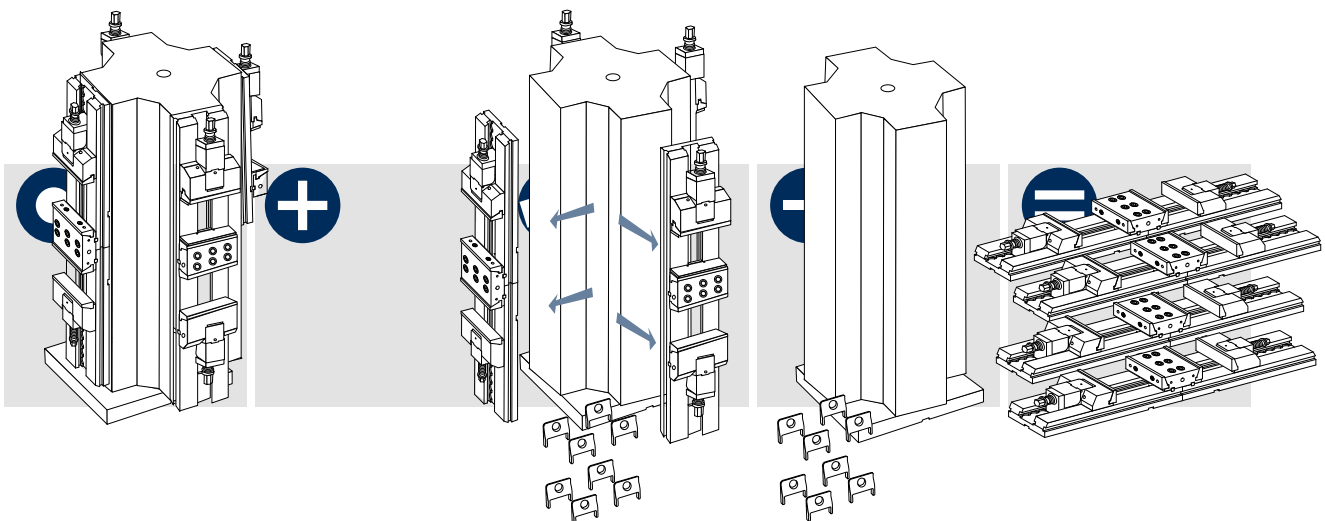



Cross cube for VCS-TCt

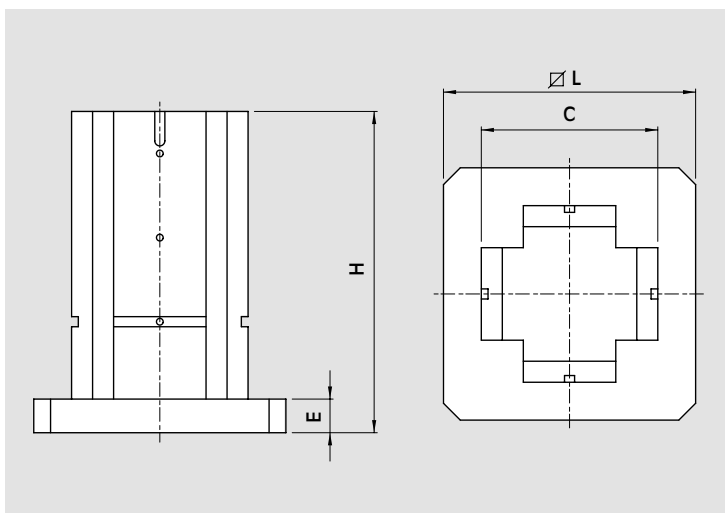

Id. No.	for type	C mm	E mm	H mm	L mm	Weight kg
58 51 80 10	TCt 110	210	40	382	300	75
58 52 80 20	TCt 150	300	40	580	400	212
58 52 80 30	TCt 150	300	40	580	500	240
58 53 80 30	TCt 200	350	40	670	500	305
58 53 80 40	TCt 200	350	45	670	630	363



Cross cube for DVCS-TCt

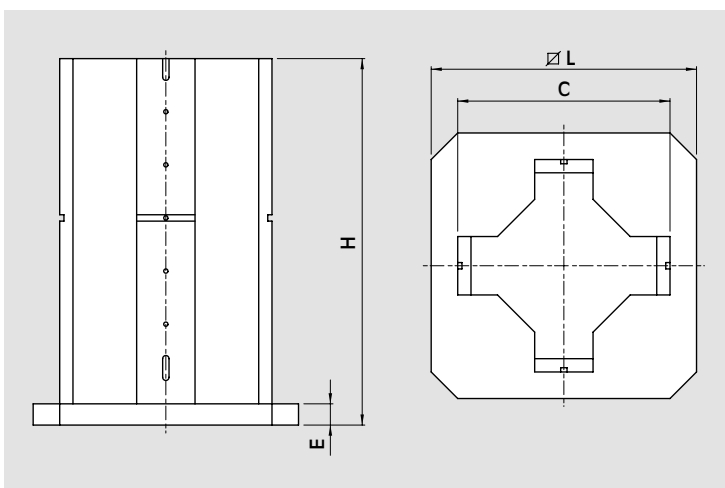

Id. No.	for type	C mm	E mm	H mm	L mm	Weight kg
58 61 80 00	DVCS-TCt 110 x ...	400	40	690	500	266
58 62 80 00	DVCS-TCt 150 x ...	550	45	840	630	458



Insert for vertical use

Id. No.	Model
58 21 33 00	VCS-TCt 110 x ...
58 22 33 00	VCS-TCt 150 x ...
58 23 33 00	VCS-TCt 200 x ...



Pair of grooved jaws

Id. No.	for type	
58 01 44 09	TC 110 x ...	
58 02 44 09	TC 150 x ...	
58 03 44 09	TC 200 x ...	



Insert for vertical use

(MVS,VCS,DVCS)

Id. No.	for type	
58 21 33 00	TC 110 x ...	
58 22 33 00	TC 150 x ...	
58 23 33 00	TC 200 x ...	



Torque wrench

Id. No.	for type	
51 50 10 01	TC 110 x ...	
51 50 10 02	TC 150 x ...	
51 50 10 03	TC 200 x ...	

**Air/oil block**

complete with cylinder and tang

Id. No.	for type	
58 01 75 00	TC 110 x ...	
58 02 75 00	TC 150 x ...	
58 03 75 00	TC 200 x ...	

**Air/oil foot pump**

with joining pipe cm 180 (71") and complete block for air/oil application.

Id. No.	for type	
77 58 01 51	TC 110 x ...	
77 58 02 51	TC 150 x ...	
77 58 03 51	TC 200 x ...	

**Air/oil foot pump**

Id. No.	for type	
71 66 03 05	TC 110 x ...	
71 66 03 05	TC 150 x ...	
71 66 03 05	TC 200 x ...	

**Air/oil manual pump**

Id. No.	for type	
71 66 03 15	TC 110 x ...	
71 66 03 15	TC 150 x ...	
71 66 03 15	TC 200 x ...	

**Pressure-gauge**

Id. No.	for type	
51 43 12 51	TC 110 x ...	
51 43 12 51	TC 150 x ...	
51 43 12 51	TC 200 x ...	



Joining pipe M. 1,80 (71")

Id. No.	for type
71 70 87 13	TC 110 x ...
71 70 87 13	TC 150 x ...
71 70 87 13	TC 200 x ...



Joining pipe M. 3 (118")

Id. No.	for type
71 70 87 14	TC - 110
71 70 87 14	TC - 150
71 70 87 14	TC - 200



Joining pipe M. 6 (236")

Id. No.	for type
71 70 87 15	TC 110 x ...
71 70 87 15	TC 150 x ...
71 70 87 15	TC 200 x ...



Pair of clamps

complete with screws and T-nuts

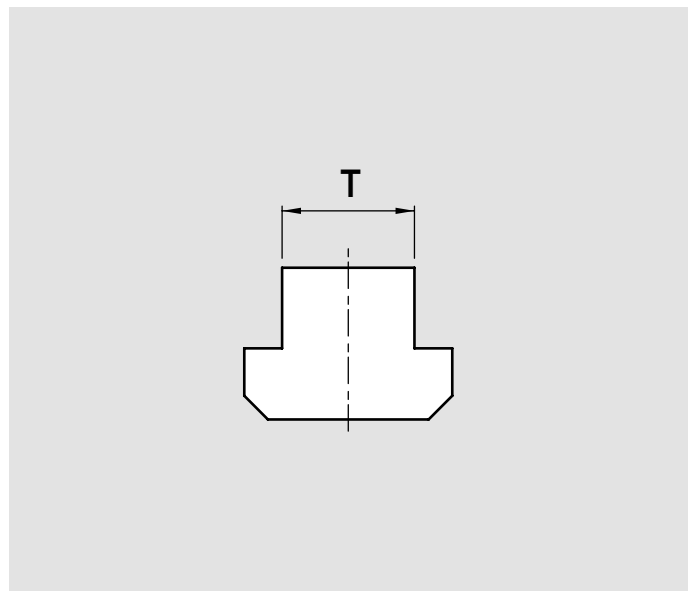

Code for T-slots					
mm 12	mm 14	mm 16	mm 18	mm 20	mm 22
58 01 27 92	58 01 27 93	58 01 27 94	58 01 27 95	58 01 27 96	58 01 27 97
58 02 27 92	58 02 27 93	58 02 27 94	58 02 27 95	58 02 27 96	58 02 27 97
58 03 27 92	58 03 27 93	58 03 27 94	58 03 27 95	58 03 27 96	58 03 27 97

for type
 TCt 110 x ...
 TCt 150 x ...
 TCt 200 x ...



Pair of T-nuts

Complete with screws at 45°

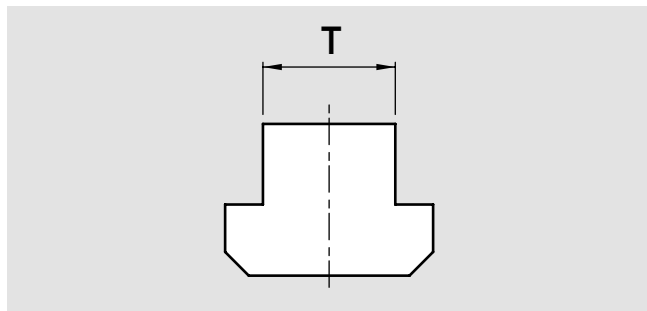

Code for T-slots					
mm 12	mm 14	mm 16	mm 18	mm 20	mm 22
58 01 25 92	58 01 25 93	58 01 25 94	58 01 25 95	58 01 25 96	58 01 25 97
58 02 25 92	58 02 25 93	58 02 25 94	58 02 25 95	58 02 25 96	58 02 25 97
58 03 25 92	58 03 25 93	58 03 25 94	58 03 25 95	58 03 25 96	58 03 25 97

for type
 TCt 110 x ...
 TCt 150 x ...
 TCt 200 x ...



Pair of positioning keys

with special dimensions

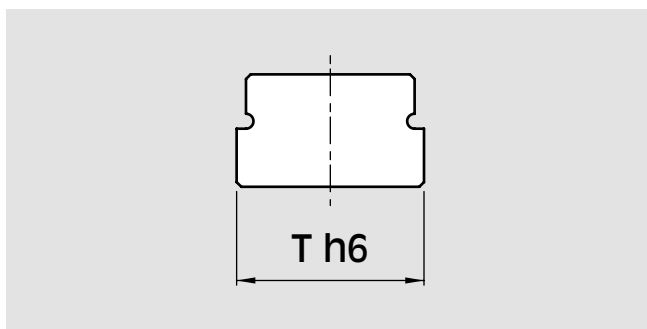

Code for T-slots					
mm 12	mm 14	mm 16	mm 18	mm 20	mm 22
-	58 01 13 93	58 01 13 94	58 01 13 95	58 01 13 96	58 01 13 97
58 02 13 92	58 02 13 93	58 02 13 94	-	58 02 13 96	58 02 13 97
58 02 13 92	58 02 13 93	58 02 13 94	-	58 02 13 96	58 02 13 97

for type
 TCt 110 x ...
 TCt 150 x ...
 TCt 200 x ...

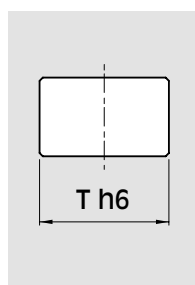

Pair of standard positioning keys

Id. No.	Model	T h6 mm
58 01 13 92	TCt - 110	12
58 02 13 95	TCt - 150	18
58 02 13 95	TCt - 200	18

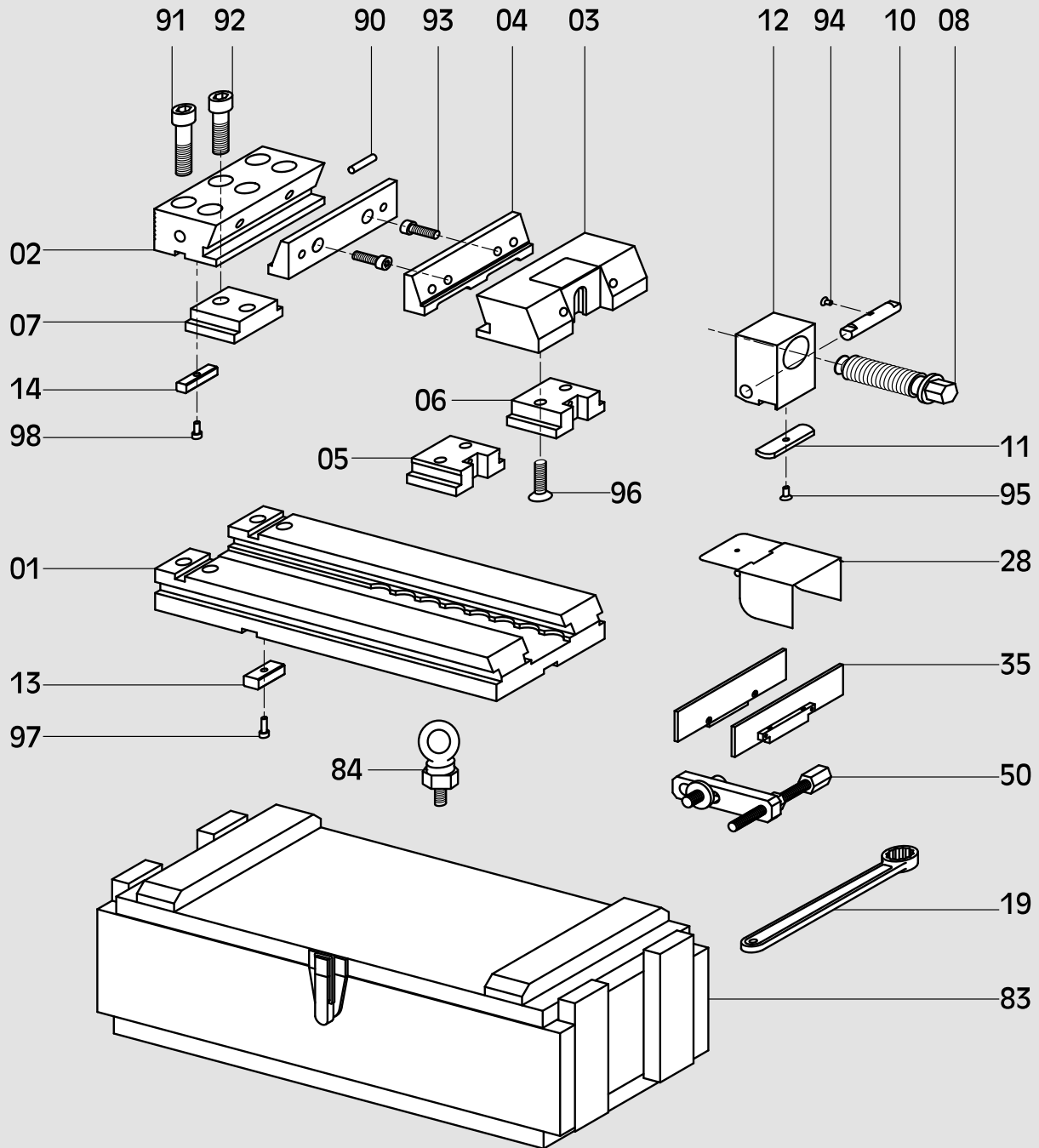

Description

01.....Base	12.....Block for clamping screw	90.....Rubber pad
02.....Fixed support	13.....Positioning key	91.....Screw TCEI
03.....Moveable support	14.....Key for support	92.....Screw TCEI
04.....Jaws	19.....Wrench	93.....Screw TCEI
05.....Floating slide-way	28.....Cover for protection	94.....Screw TPS
06.....Rigid slide-way	of the screw	95.....Screw TPS
07.....Fixed slide-way	35.....Pair of CLAK parallels	96.....Screw TPS
08.....Clamping screws	50.....Work stop	97.....Screw TCEI
10.....Contrast pin	83.....Wooden packing case	98.....Screw TCEI
11.....Positioning plate	84.....Eye bolt	



Pair of smooth jaws

Id. Nr.	for type	
58 01 04 09	TC 110 x ...	
58 02 04 09	TC 150 x ...	
58 03 04 09	TC 200 x ...	



Fixed support with jaw

Id. Nr.	for type	
58 01 72 10	TC 110 x ...	
58 02 72 10	TC 150 x ...	
58 03 72 10	TC 200 x ...	



Moveable support with jaw

Id. Nr.	for type	
58 01 73 10	TC 110 x ...	
58 02 73 10	TC 150 x ...	
58 03 73 10	TC 200 x ...	



Floating slide-way

Id. Nr.	for type	
58 01 05 00	TC 110 x ...	
58 02 05 00	TC 150 x ...	
58 03 05 00	TC 200 x ...	



Rigid slide-way

Id. Nr.	for type	
58 01 06 00	TC 110 x ...	
58 02 06 00	TC 150 x ...	
58 03 06 00	TC 200 x ...	



Fixed slide-way

Id. Nr.	for type	
58 01 07 00	TC 110 x ...	
58 02 07 00	TC 150 x ...	



Pair of keys for fixed support

Id. Nr.	for type	
58 01 14 09	TC 110 x ...	
58 02 14 09	TC 150 x ...	
58 03 14 09	TC 200 x ...	



Wrench

Id. Nr.	for type	
58 01 19 00	TC 110 x ...	Hexagon 18
58 02 19 00	TC 150 x ...	Hexagon 22
58 03 19 00	TC 200 x ...	Hexagon 27



Complete clamping block (new type)

Id. Nr.	for type	
58 01 74 11	TC 110 x ...	
58 02 74 11	TC 150 x ...	
58 03 74 11	TC 200 x ...	



Block for clamping screw (new type)

Id. Nr.	for type	
58 01 12 12	TC 110 x ...	
58 02 12 12	TC 150 x ...	
58 03 12 12	TC 200 x ...	



Clamping screw

Id. No.	for type	
58 01 08 12	TC 110 x ...	
58 02 08 12	TC 150 x ...	
58 03 08 12	TC 200 x ...	



Contrast pin

Id. No.	for type	
58 01 10 01	TC 110 x ...	
58 02 10 01	TC 150 x ...	
58 03 10 01	TC 200 x ...	



Positioning plate

Id. No.	for type	
58 01 11 11	TC 110 x ...	
58 02 11 11	TC 150 x ...	
58 03 11 11	TC 200 x ...	

**Work stop**

Id. No.	for type	
58 01 50 00	TC 110 x ...	
58 02 50 00	TC 150 x ...	
58 03 50 00	TC 200 x ...	

**Cover for protection of the screw**

Id. No.	for type	
58 01 28 10	TC 110 x ...	
58 02 28 10	TC 150 x ...	
58 03 28 10	TC 200 x ...	

**Block for cylinder**

Id. No.	for type	
58 01 12 20	TC 110 x ...	
58 02 12 20	TC 150 x ...	
58 03 12 20	TC 200 x ...	



Tang for cylinder

Id. No.	for type
58 01 16 00	TC 110 x ...
58 02 16 00	TC 150 x ...
58 03 16 00	TC 200 x ...



Can of oil

Id. No.	for type
10 72 99 40	TC 110 x ...
10 72 99 40	TC 150 x ...
10 72 99 40	TC 200 x ...