

Modular clamping equipment

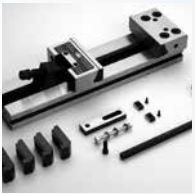

LC
Modular clamping equipment

Page 3.2.3

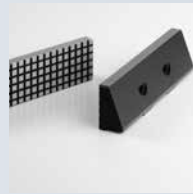

LC
Spare parts for clamping equipment

Page 3.2.8



LC
Accessories for clamping equipment

Page 3.2.4

LC
is...



LOW COST

The new LC VISE joins the original OML TC and MC VISES
as "low cost" solution.

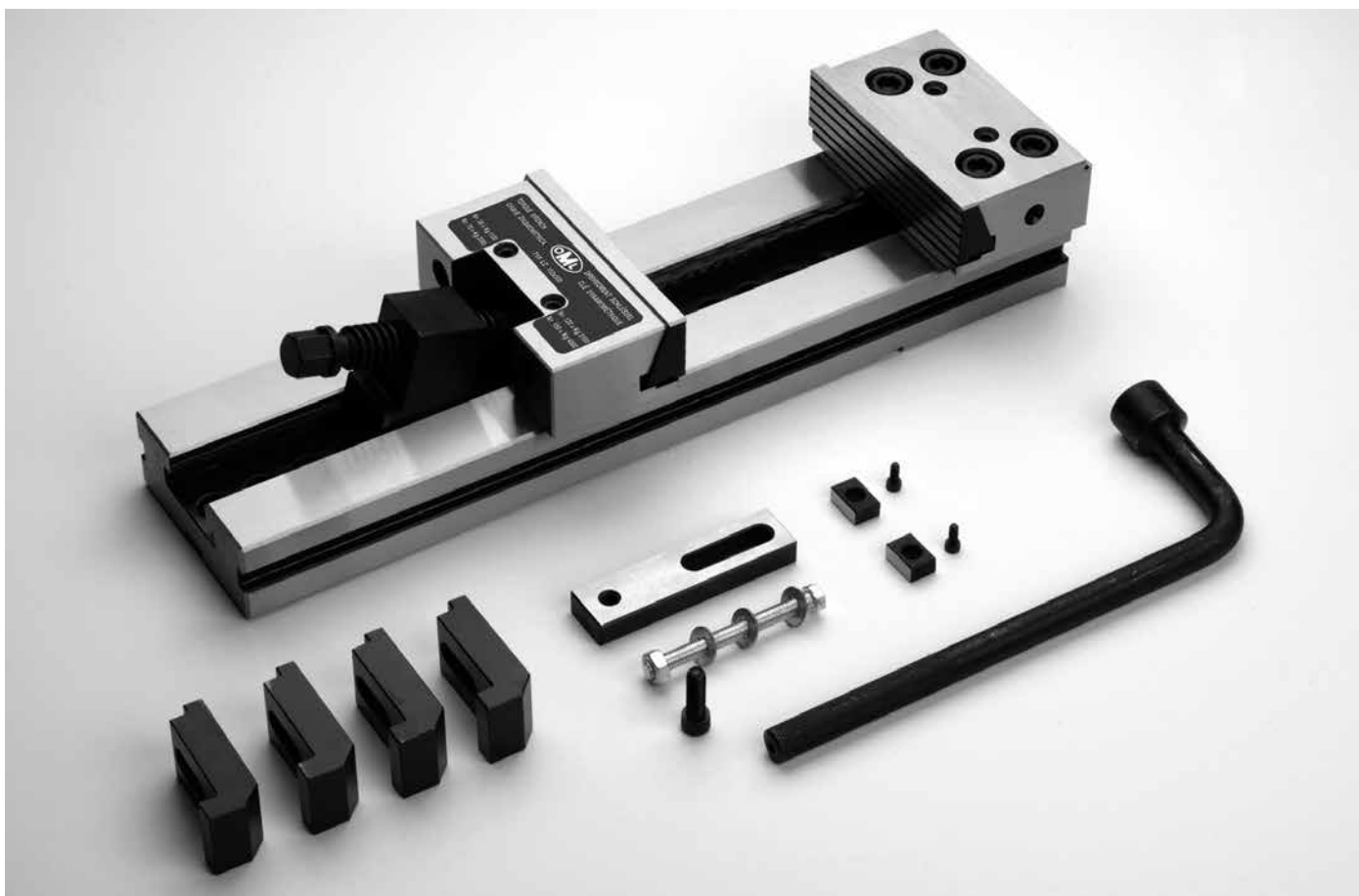

Clamping equipment LC complete with: wrench, rigid slide way (floating slide-way at request for raw workpiece), work stop, pair of positioning keys h6, cover for protection of the screw, 4 clamps, cardboard box.

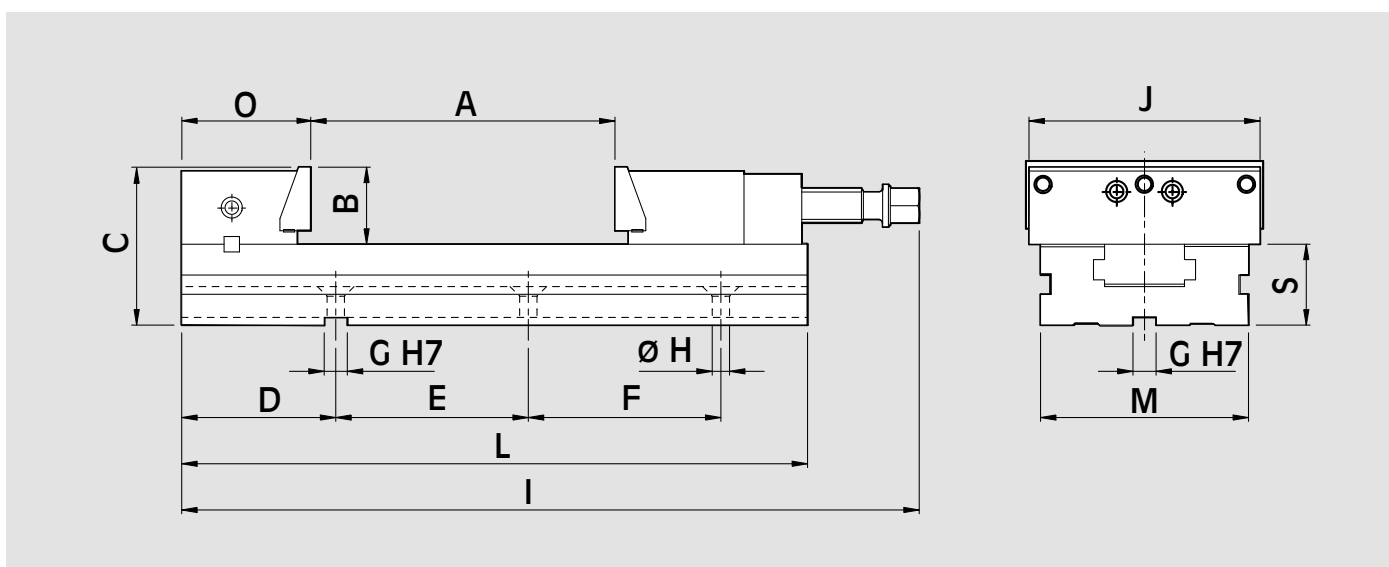

Id. No.	type	A mm	B mm	C mm	D mm	E mm	F mm	G mm	H mm	I mm	J mm	L mm	M mm	O mm	S mm	weight kg
77 58 95 01	LC 125 x 150	150	40	80	111	100	100	16	8,5	410	125	345	95	77,9	40	13
77 58 96 01	LC 150 x 200	200	50	100	122,5	100	100	16	12,5	500	150	420	125	89,4	50	26
77 58 96 02	LC 150 x 300	300	50	100	122,5	100	100	16	12,5	600	150	520	125	89,4	50	29
77 58 97 01	LC 200 x 300	300	65	135	145	100	100	16	12,5	680	200	595	170	113	70	69
77 58 97 02	LC 200 x 400	400	65	135	145	100	100	16	12,5	780	200	695	170	113	70	74

Swivel base for clamping equipment LC

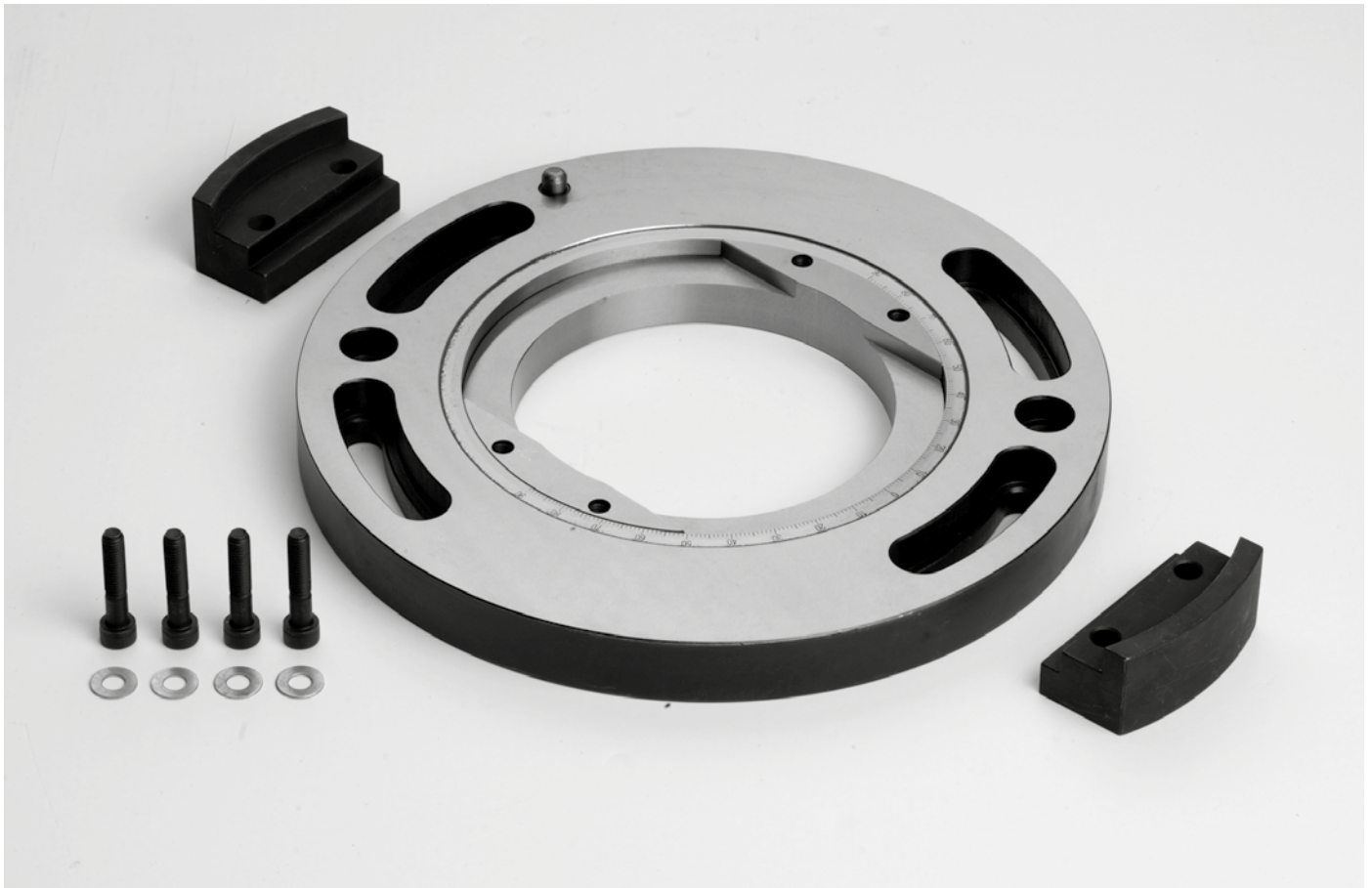

Id. No.	for type
77 58 95 50	LC 125
77 58 96 50	LC 150
77 58 97 50	LC 200

LC extension element

with pair of positioning keys (at customer's choice)

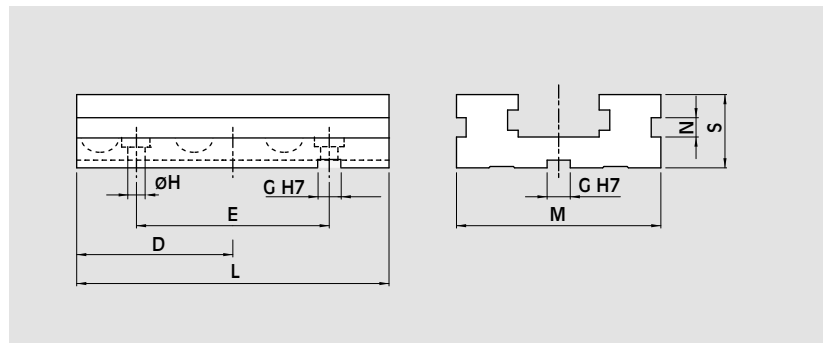
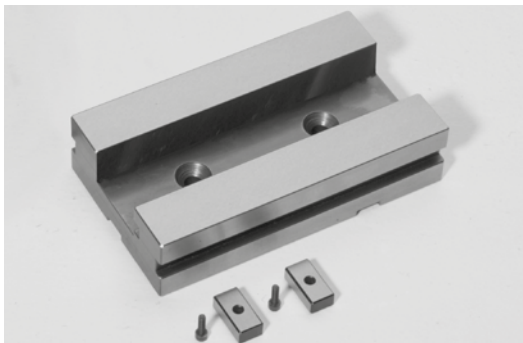

Id. No.	for type	D mm	E mm	G mm	H mm	L mm	M mm	S mm
58 95 17 00	LC 125	40	40	16	8,5	160	95	40
58 96 17 00	LC 150	40	50	16	13	230	125	50
58 97 17 00	LC 200	50	100	16	17	300	170	70

Complete extension element LC

with pair of positioning keys (at customer's choice)

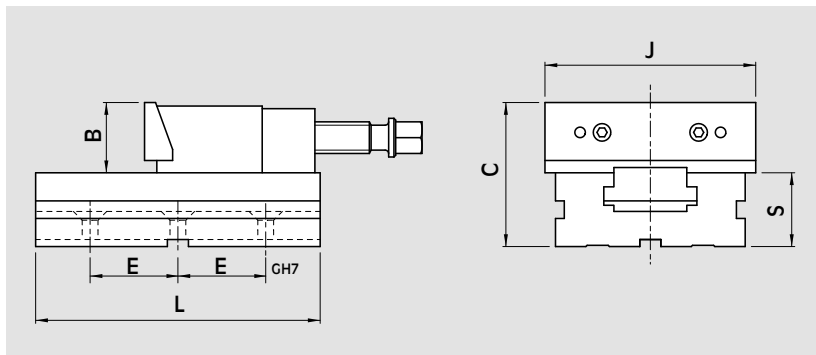
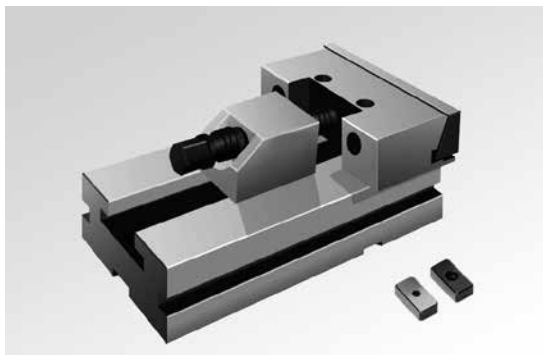

Id. No.	for type	B mm	C mm	J mm	L mm	S mm	E mm	Weight kg
58 95 71 20	LC 125	40	80	125	160	40	40	6,3
58 96 71 20	LC 150	50	100	150	230	50	50	14,2
58 97 71 20	LC 200	65	135	200	300	70	100	35,0

Base with fixed support LC

with pair of positioning keys (at customer's choice)

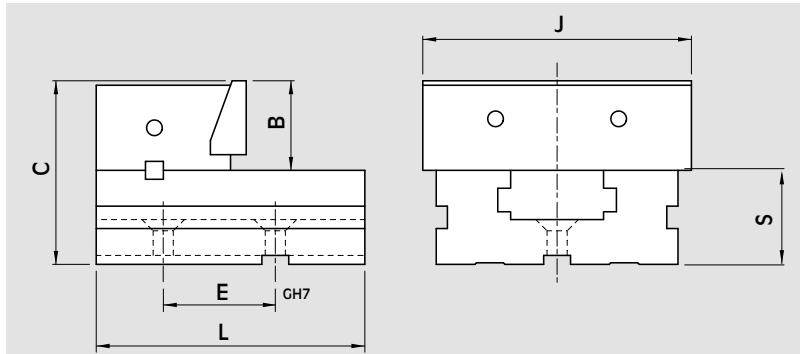

Id. No.	for type	B mm	C mm	J mm	L mm	S mm	E mm	Weight kg
58 95 70 20	LC 125	40	80	125	160	40	40	5,8
58 96 70 20	LC 150	50	100	150	230	50	50	12,6
58 97 70 20	LC 200	65	135	200	300	70	100	29,8

Base with double fixed support - LC

with pair of positioning keys (at customer's choice)

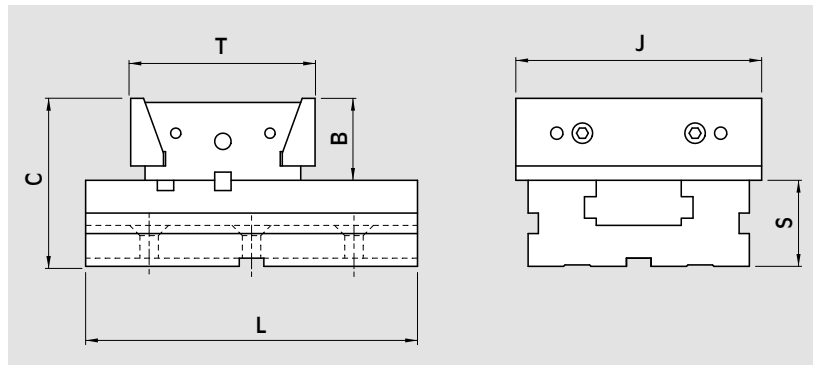
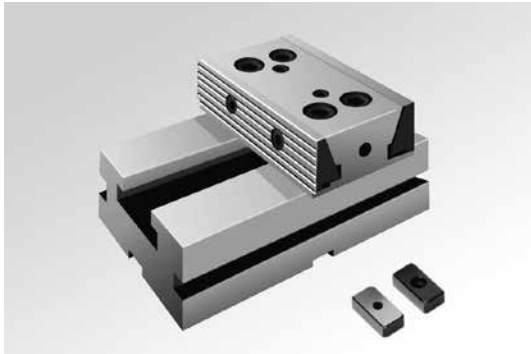

Id. No.	for type	B mm	C mm	J mm	L mm	S mm	T mm	Weight kg
58 95 70 60	LC 125	40	80	125	160	40	84,8	6,0
58 96 70 60	LC 150	50	100	150	230	50	101,8	13,3
58 97 70 60	LC 200	65	135	200	300	70	132,8	30,0

Middle jaw LC

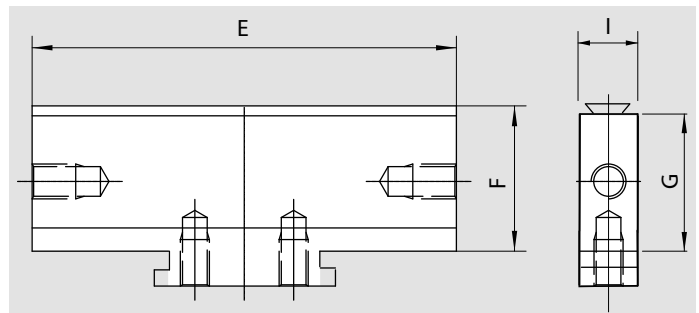

Id. No.	for type	E mm	F mm	G mm	I mm
58 95 41 10	LC 125	121	38	33	30
58 96 41 10	LC 150	146	48	43	30
58 97 41 10	LC 200	196	68	53	30

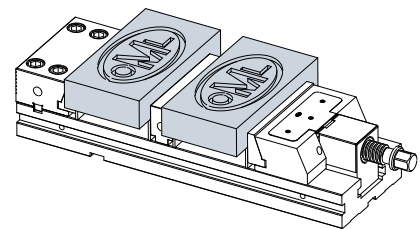

Floating movable support with jaw LC

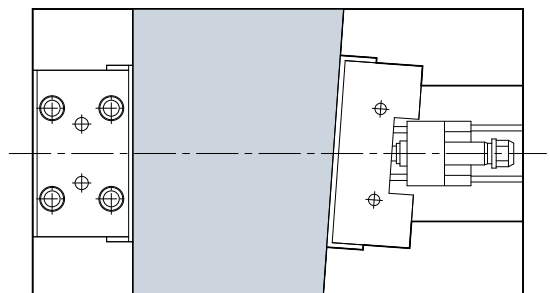

Id. No.	for type
58 95 73 50	LC 125
58 96 73 50	LC 150
58 97 73 50	LC 200

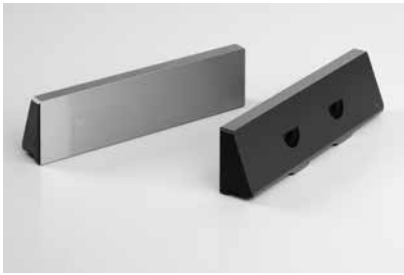

Pair of smooth jaws LC

Id. No.	for type
58 95 04 09	LC 125
58 96 04 09	LC 150
58 97 04 09	LC 200

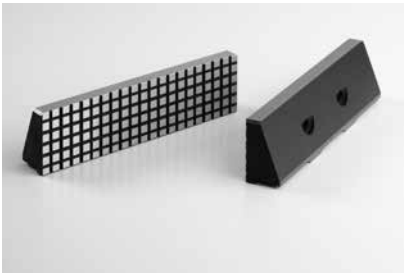

Pair of serrated jaws LC

Id. No.	for type
58 95 44 29	LC 125
58 96 44 29	LC 150
58 97 44 29	LC 200



Insert for vertical use

Id. No.	for type
58 95 33 00	LC 125
58 96 33 00	LC 150
58 97 33 00	LC 200



Set of 6 pairs of parallels (no clak) LC

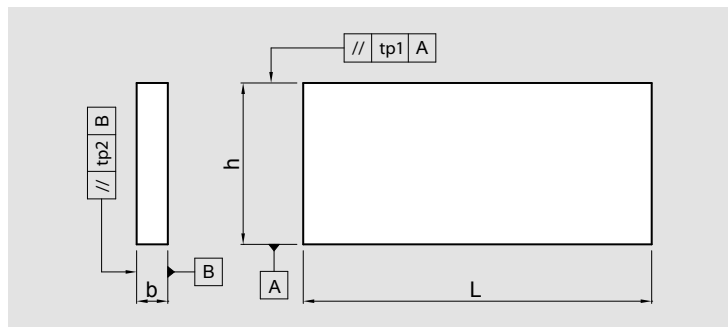

Id. No.	for type	h mm	L mm	B mm	tolerance	
					A	B
58 96 92 06	LC 150	25 - 30 - 35 - 40 - 45 - 47	150	8	0,009	0,005
58 97 92 06	LC 200	40 - 45 - 50 - 55 - 60 - 62	200	8	0,009	0,005

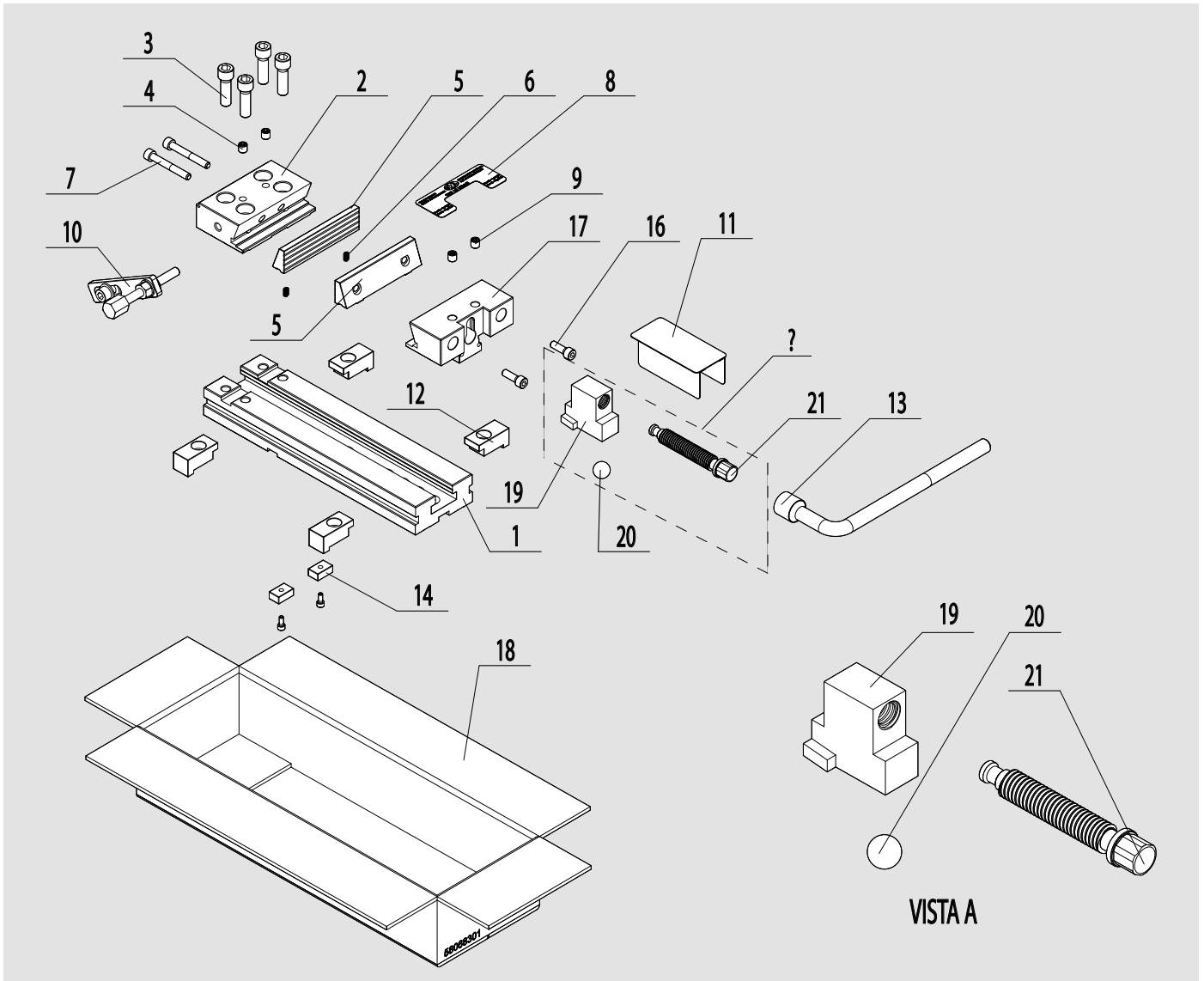

Pos.	Description	Quantity	Pos.	Description	Quantity
21	Clamping screw	1	10	Workstop	1
20	Positioning ball	1	9	Screw STEI	2
19	Block for clamping screw	1	8	Label	1
18	Cardboard box	1	7	Screw STEI	2
17	Guided movable support	1	6	Spring	4
16	Screw TCEI	2	5	Grooved jaw	2
15	Screw TCEI	2	4	Screw STEI	2
14	Positioning key	2	3	Screw STEI	4
13	Wrench	1	2	Fixed support	1
12	Set 4 clamps	4	1	Base	1
11	Cover for protection of the screw	1			

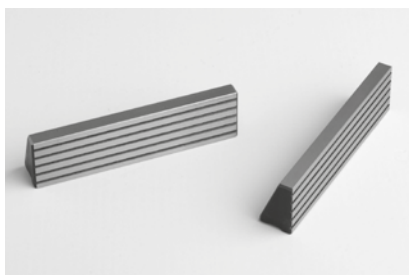

Pair of grooved jaws

Id. No.	for type	
58 95 44 19	LC 125	
58 96 44 19	LC 150	
58 97 44 19	LC 200	



Fixed support with jaw

Id. No.	for type	
58 95 72 10	LC 125	
58 96 72 10	LC 150	
58 97 72 10	LC 200	

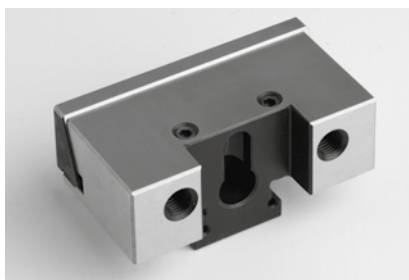

Guided support with jaw

Id. No.	for type	
58 95 73 60	LC 125	
58 96 73 60	LC 150	
58 97 73 60	LC 200	



Wrench

Id. No.	for type	
58 95 19 00	LC 125	
58 96 19 00	LC 150	
58 97 19 00	LC 200	



Complete clamping block

Id. No.	for type	
58 95 74 10	LC 125	
58 96 74 10	LC 150	
58 97 74 10	LC 200	



Block for clamping screw

Id. No.	for type	
58 95 12 10	LC 125	
58 96 12 10	LC 150	
58 97 12 10	LC 200	



Clamping screw

Id. No.	for type
58 95 08 10	LC 125
58 96 08 10	LC 150
58 97 08 10	LC 200



Positioning ball

Id. No.	for type
58 95 10 00	LC 125
58 96 10 00	LC 150
58 97 10 00	LC 200



Pair of positioning keys

Id. No.	T h6	for type
58 96 13 92	16/12	LC 125 - LC 150 - LC 200
58 96 13 93	16/14	
58 96 13 94	16/16	
58 96 13 95	16/18	
58 96 13 96	16/20	
58 96 13 97	16/22	



Work stop

Id. No.	for type
58 95 50 00	LC 125
58 96 50 00	LC 150
58 97 50 00	LC 200



Cover for protection of the screw

Id. No.	for type
58 95 28 10	LC 125
58 96 28 10	LC 150
58 97 28 10	LC 200



Set of 2 pairs of clamps

Id. No.	for type
58 95 27 09	LC 125
58 96 27 09	LC 150
58 97 27 09	LC 200