

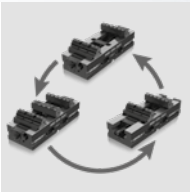

## Vice Self-centering | Double Clamping | Fixed



### IMG

#### Vice

- Self-centering
- Double Clamping
- Fixed

Page 5.1.2

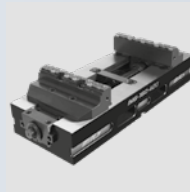

### IMG

#### Self-centering | Double Clamping | Fixed

- IMG 160 - 420

Page 5.1.20



### IMG

#### Self-centering | Double Clamping | Fixed

- IMG 88 - 130

Page 5.1.10



### IMG

#### Accessories

Page 5.1.22



### IMG

#### Self-centering | Double Clamping | Fixed

- IMG 125 - 180

Page 5.1.12

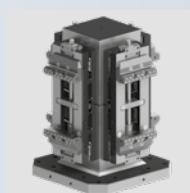

### IMG

#### Accessories

- Riser
- Alu Pyramid
- Triangular tombstone
- Tombstone

Page 5.1.26



### IMG

#### Self-centering | Double Clamping | Fixed

- IMG 125 - 220

Page 5.1.14



### Clamping Pins

#### Accessories

- For APS 140 and APS 190

Page 5.1.36



### IMG

#### Self-centering | Double Clamping | Fixed

- IMG 125 - 320

Page 5.1.16



### CLAK System

#### Accessories

Page 5.1.38



### IMG

#### Self-centering | Double Clamping | Fixed

- IMG 160 - 270

Page 5.1.18



### IMG

- Spare parts

Page 5.1.40



# Self-centering vice | Double

## SinterGrip jaws

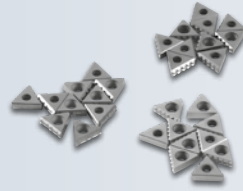
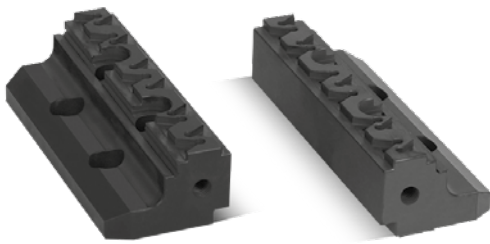

**SinterGrip jaws:**  
Reversible jaws for minimum clamping depth and without pre-machining

## Wide clamping range

Maximum flexibility  
For external and internal clamping

## BASIC jaws

without Sintergrip inserts for **IMG BASIC** models

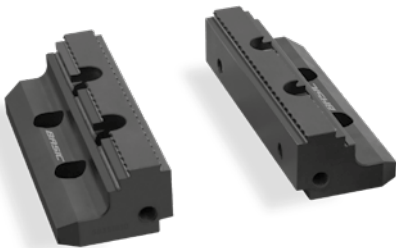

## Mechanical clamping

Totally protected with patented telescopic system.

The large power transmission allows high performance in the manufacturing process

## Interface

For Zero Point clamping systems and mounting holes as standard



Find out more

# Clamping | Fixed

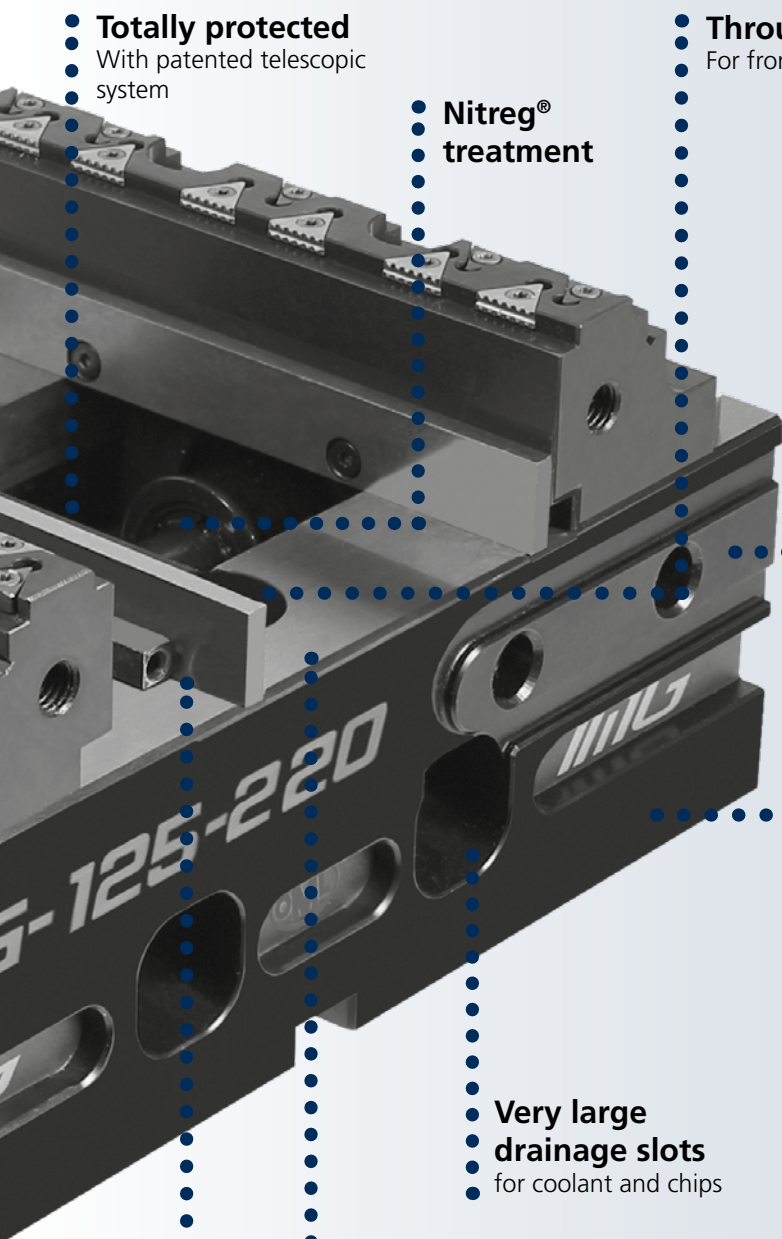

- **Totally protected**  
With patented telescopic system

- **Nitreg® treatment**

- **Through holes**  
For frontal clamping

- **Ideal**  
For automation and palletizing systems

- **Flexible mounting**  
on machine tool pallet using clamps (optional)

**Double clamping jaw**  
(for double clamping)



**Retainer plate**  
(for fixed clamping)



- **Very large drainage slots**  
for coolant and chips

- **Treated and precision ground guides**  
for maximum accuracy and repeatability

- **Parallels**  
with quick change Clak System

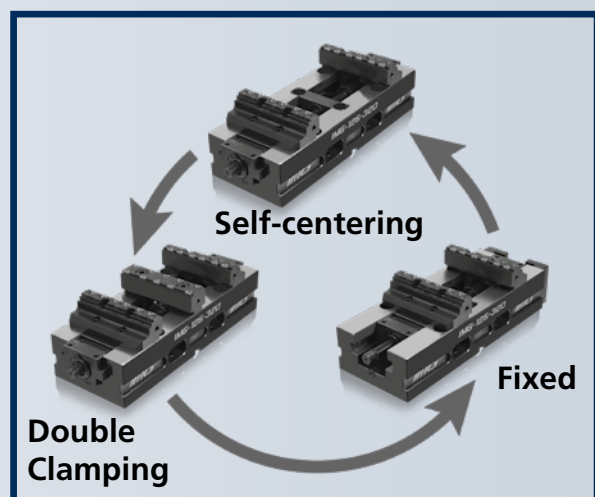

## Vice Self-centering | Double Clamping | Fixed

### PATENTED PROTECTED SCREW



**IMG** vices have a fully protected operating screw with a patented telescopic system.

This innovation makes it possible to avoid having to remove the jaws in order to find the clamping position. In fact, normally, vices with protected screws use the slide-way as a protection.

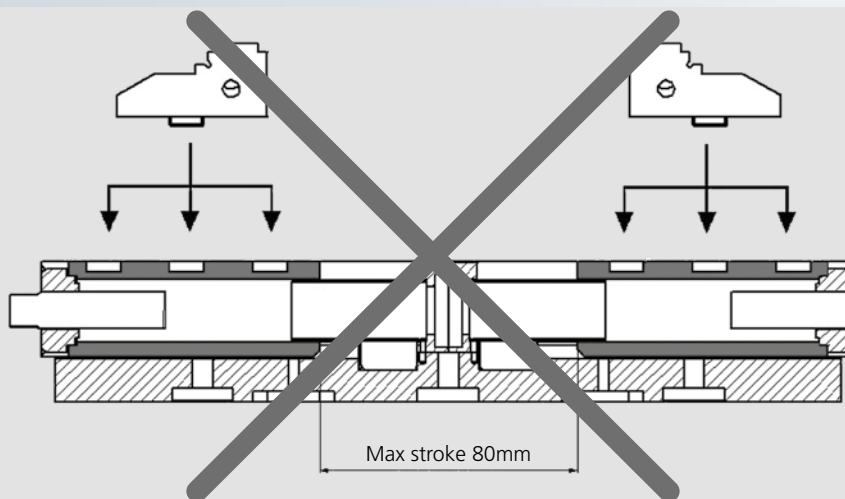

This type of solution forces continuous displacement of the jaws in the appropriate seat.

**IMG**, on the contrary, while keeping the screw completely protected, allows the continuous movement of opening and closing of the vice.

### Clamping force

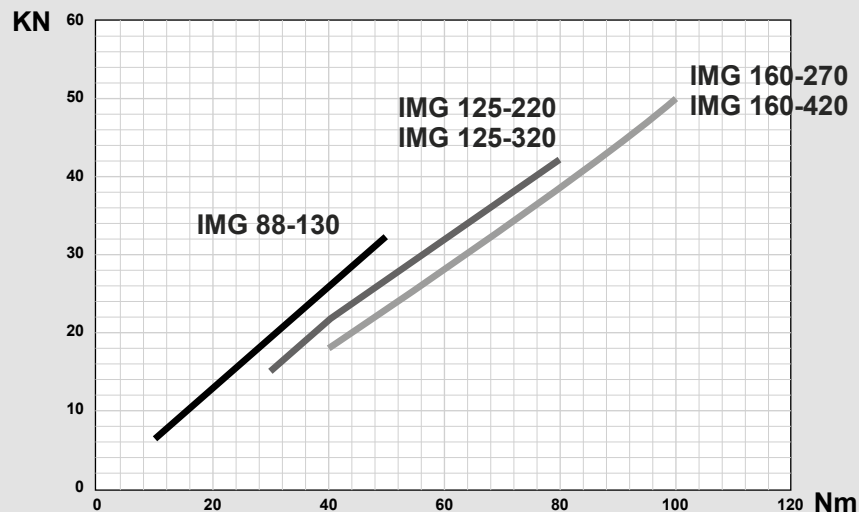

Clamping forces valid for self-centering, Double clamping, Fixed jaw





## Vice Self-centering | Double Clamping | Fixed

### IMG BASIC

The **IMG Basic** models have the same characteristics as the **IMG** vises with the only difference of mounting **Basic jaws** without SinterGrip inserts.

#### BASIC jaws

without Sintergrip inserts for **IMG BASIC** models



## Vice Self-centering | Double Clamping | Fixed

### MODULAR

The IMG self-centering vices can be easily transformed into fixed vices or double clamping vices.

Self-centering

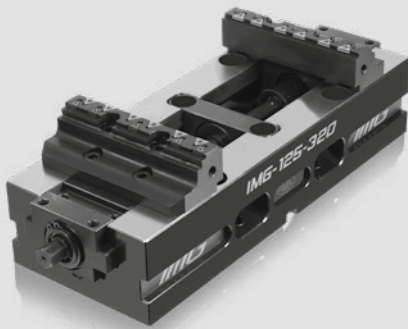

Double Clamping

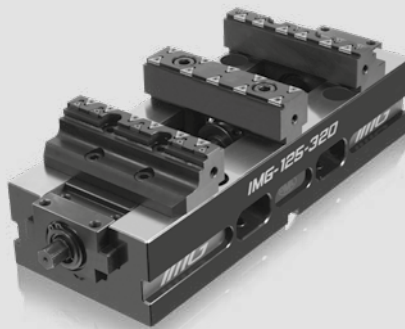

Fixed



The double clamping vices have a completely compensating mechanism (until zero), therefore it is possible to clamp 2 pieces of different sizes.

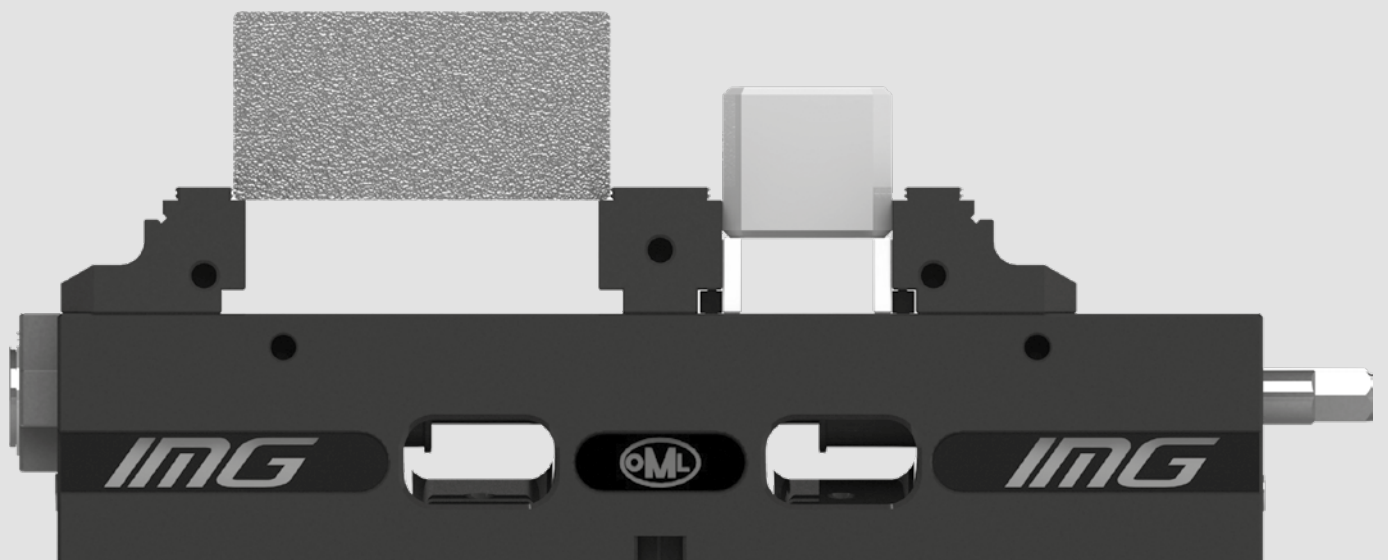



# IMG

5.1

## Modular

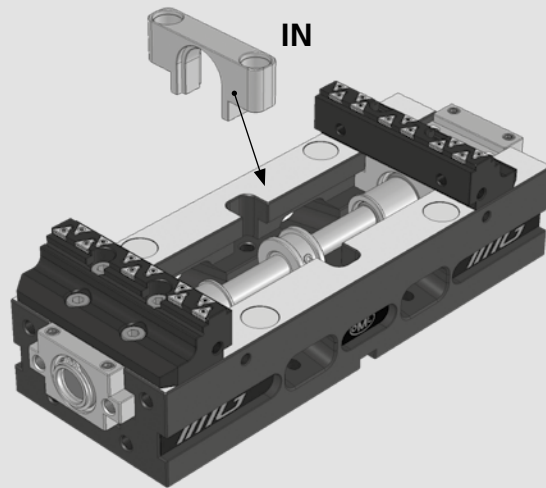

Self-centering

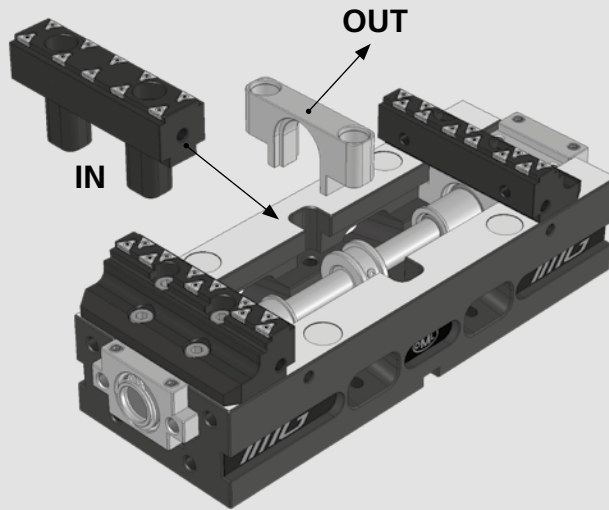

Double Clamping

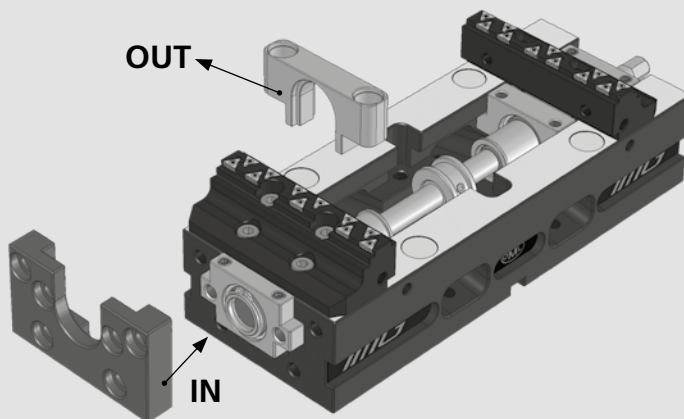

Fixed

## Vice Self-centering | Double Clamping | Fixed

### HIGH CLAMPING PERFORMANCE

IMG vices clamp up to 55 kN.

The clamping force combined with the patented SinterGrip system guarantees high performance.

1 OP.

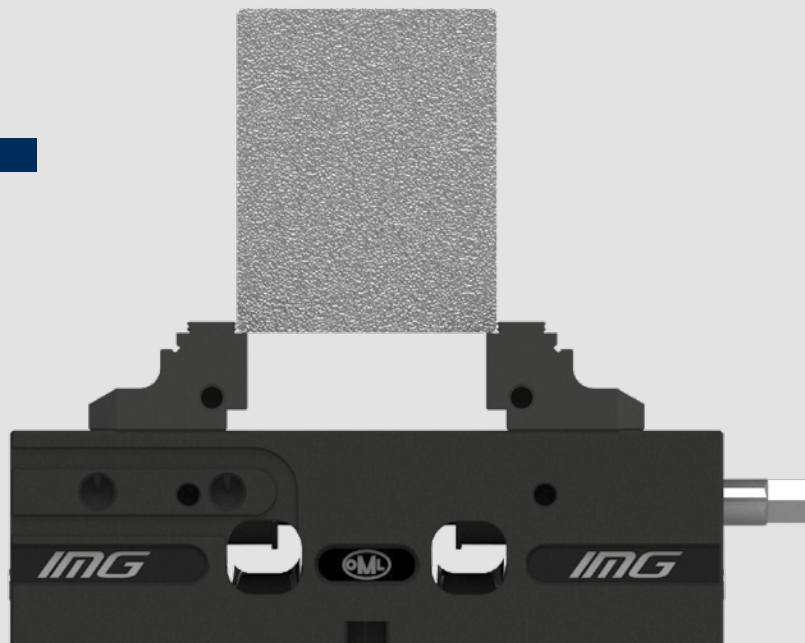

2 OP.

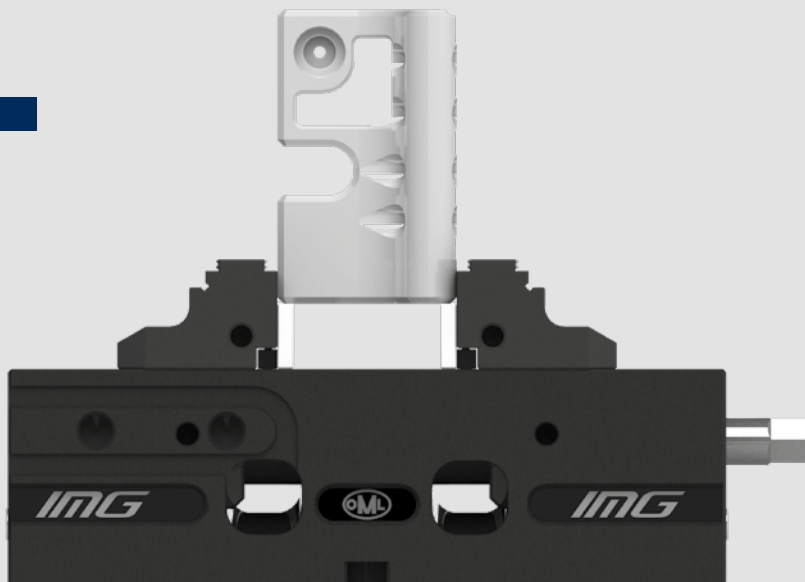





# SinterGrip

Our new patented product **SinterGrip** is born to satisfy the current need to clamp a workpiece for very few millimeters (with SinterGrip 3,5 mm clamping surface), and this for the following reasons:

- 1) In order to machine the workpiece completely in a single operation (especially for 5 axis machines);
- 2) In order to save money for the raw materials, especially when they have a big impact on the price (aluminum, titanium, etc.)

Indirectly to these reasons, and in order to improve the performance of the machine tool and the tools

**higher cutting speed +  
higher feed rate =  
bigger volume of metal removed =  
less time to machine the workpiece**

the market requires safe clamping, which could at the same time possibly avoid the deformations of the piece itself.

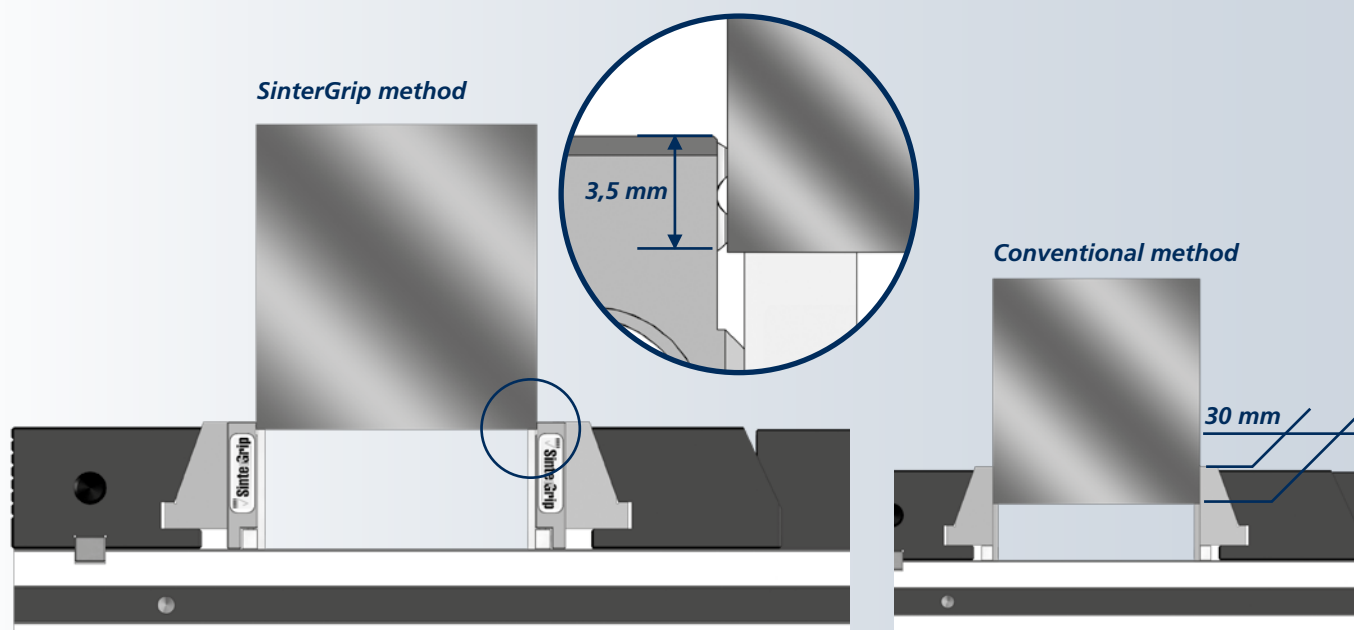

**Only 3,5 mm clamping surface**, no need of pre-machining the workpiece, clamping stability, higher cutting rate: **SinterGrip** brings only advantages compared to the traditional systems.

On the contrary, traditional systems need, for the clamping of the workpiece, a bigger clamping surface, with the result of waste of raw materials and greater possibility of deformation of the workpiece.



■ Patented protected screw

### Applications / Customer Benefits

- Highly precise self-centering clamping with maximum repeatability
- Totally protected
- Compact design for better accessibility and very large drainage slots
- Jaws with SinterGrip clamping inserts for minimum workpiece clamping depth without pre-machining
- Type **IMG BASIC** with jaws without SinterGrip inserts
- Wide clamping range
- Ideal for OP 10 and OP 20

### Technical features

- Self-centering clamping
- Clamping force up to 32 kN (50 Nm)
- Jaw width 87,5 mm
- Interface for zero point systems APS / TDM and Lang 52 mm as standard

### Standard equipment

Wrench, jaws, Sintergrip inserts.

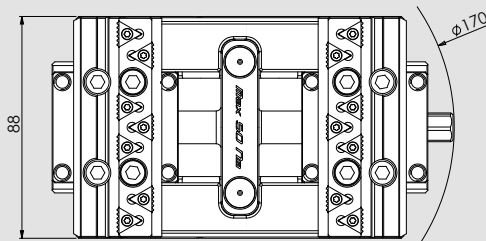
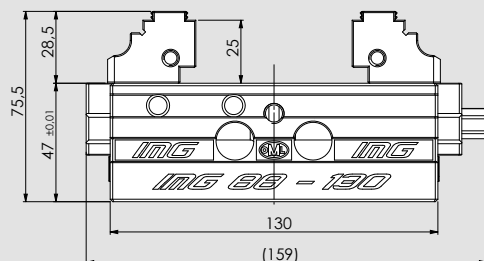
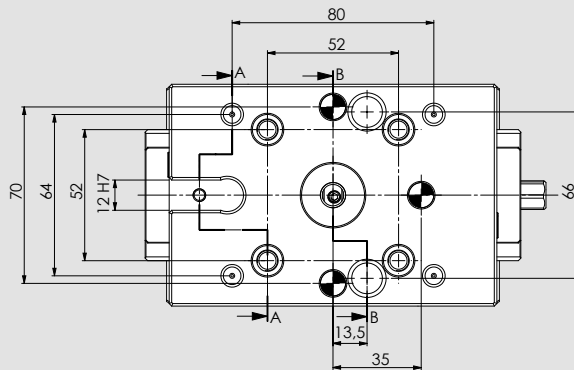

SECTION A-A

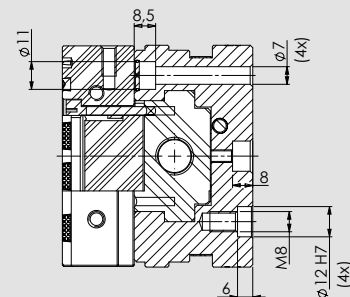

SECTION B-B

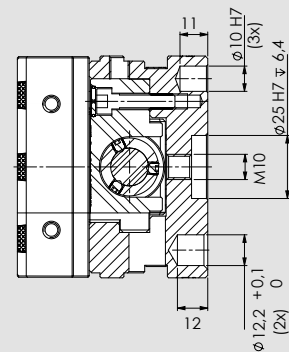

Type	Id. No.	Weight
IMG 88 - 130 with SinterGrip jaws <b>STD</b>	77583411	4,5 Kg
IMG 88 - 130 with SinterGrip jaws <b>ALU</b>	77583412	4,5 Kg
IMG 88 - 130 with SinterGrip jaws <b>HRC</b>	77583413	4,5 Kg
IMG 88 - 130 <b>Basic</b>	77583414	4,5 Kg
IMG 88 - 130 body only	77583401	3,5 Kg

■ Patented protected screw

Self-centering

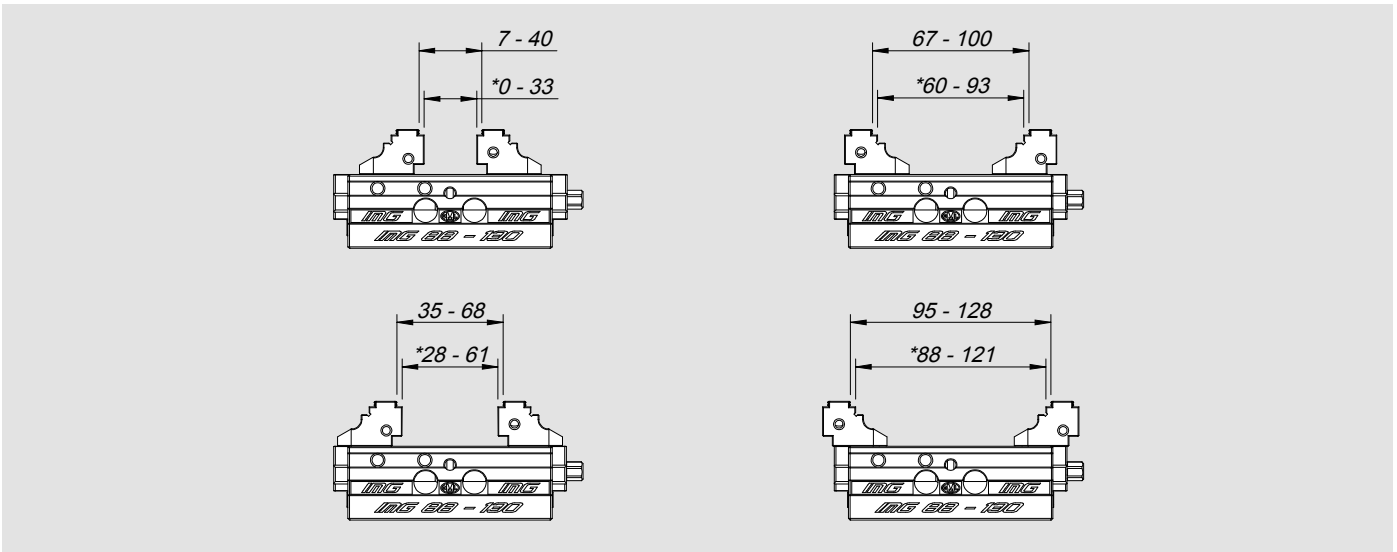

Double Clamping

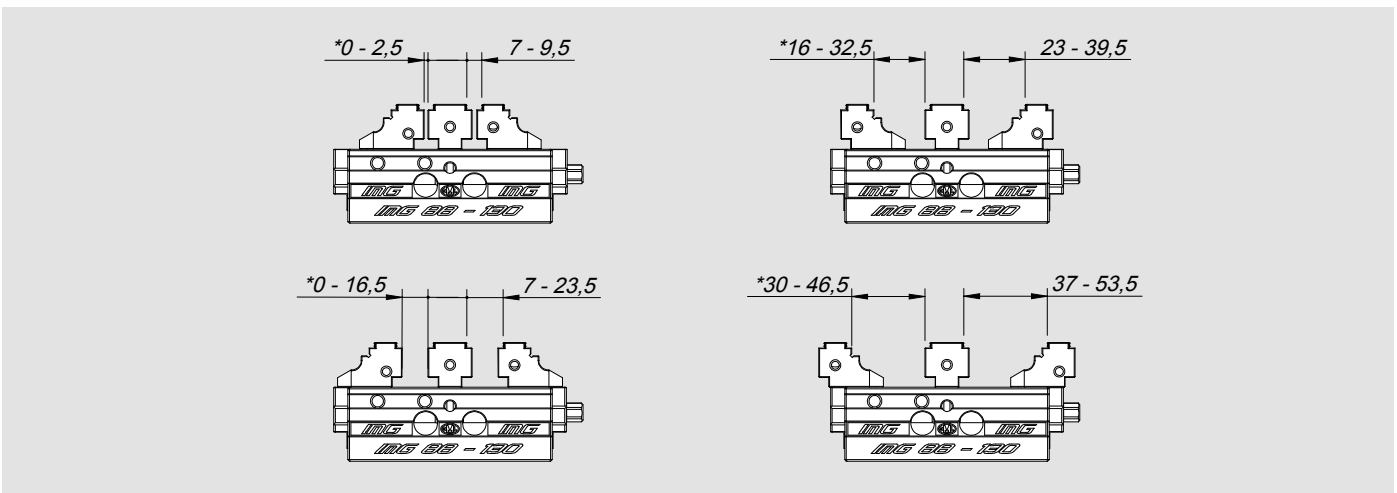

Fixed

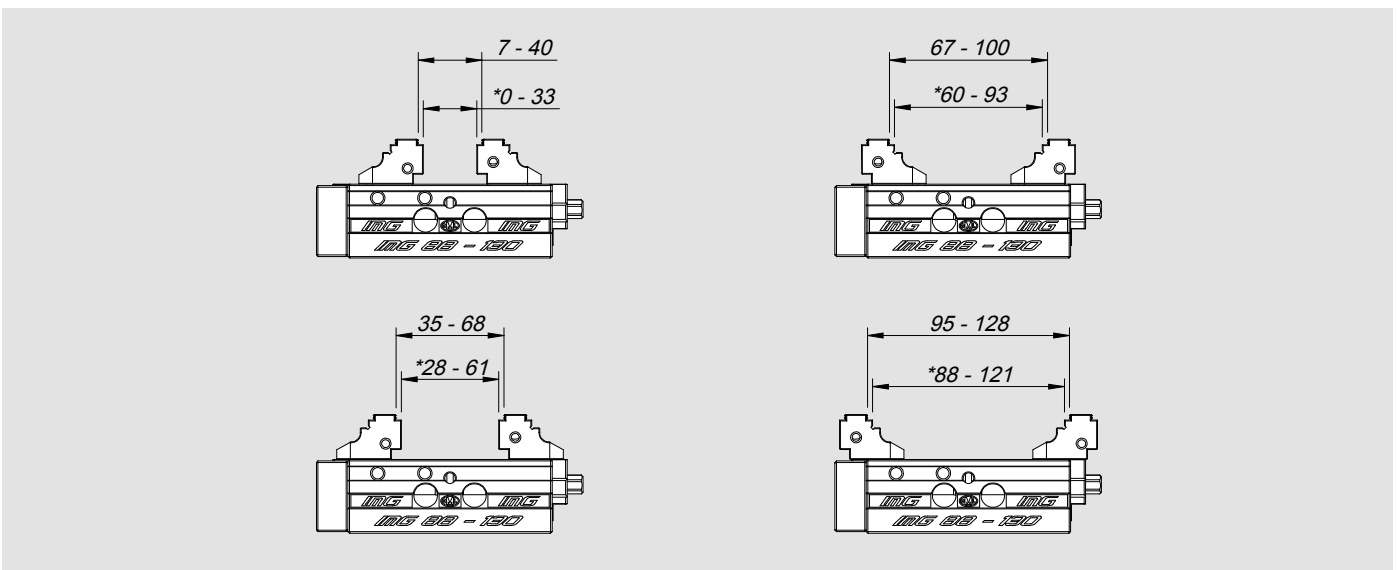

\* Opening with smooth jaws

Valid dimensions for both SinterGrip and Basic type

# IMG 125 - 180

## Self-centering vice | Double Clamping | Fixed

■ Patented protected screw



### Applications / Customer Benefits

- Highly precise self-centering clamping with maximum repeatability
- Totally protected
- Compact design for better accessibility and very large drainage slots
- Jaws with SinterGrip clamping inserts for minimum workpiece clamping depth without pre-machining
- Type **IMG BASIC** with jaws without SinterGrip inserts
- Wide clamping range
- Ideal for OP 10 and OP 20

### Technical features

- Self-centering clamping
- Clamping force up to 40 kN (80 Nm)
- Jaw width 125 mm
- Interface for zero point systems APS / TDM and Lang 52 / 96 mm as standard

### Standard equipment

Wrench, jaws, Sintergrip inserts.

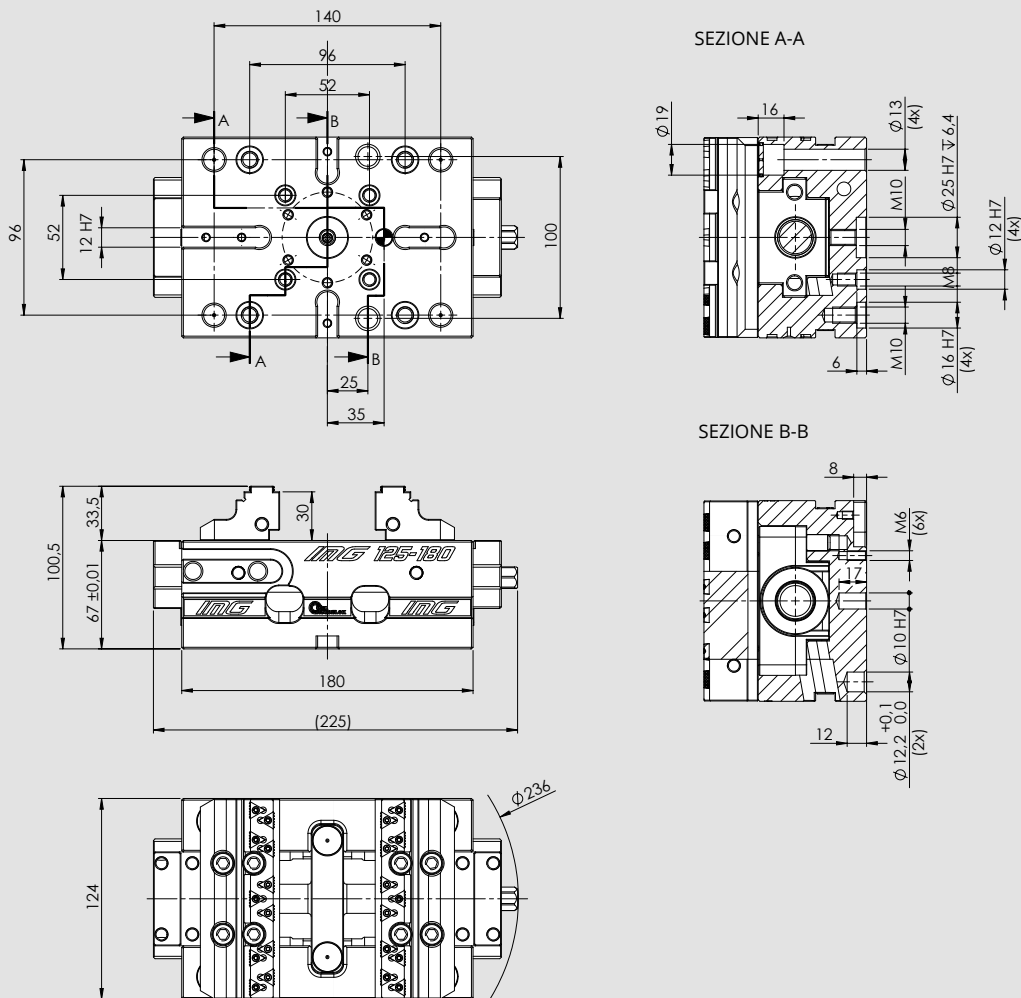

Type	Id. No.	Weight
IMG 125 - 180 with SinterGrip jaws <b>STD</b>	77583531	12 Kg
IMG 125 - 180 with SinterGrip jaws <b>ALU</b>	77583532	12 Kg
IMG 125 - 180 with SinterGrip jaws <b>HRC</b>	77583533	12 Kg
IMG 125 - 180 <b>Basic</b>	77583534	12 Kg
IMG 125 - 180 body only	77583503	10 Kg

■ Patented protected screw

Self-centering

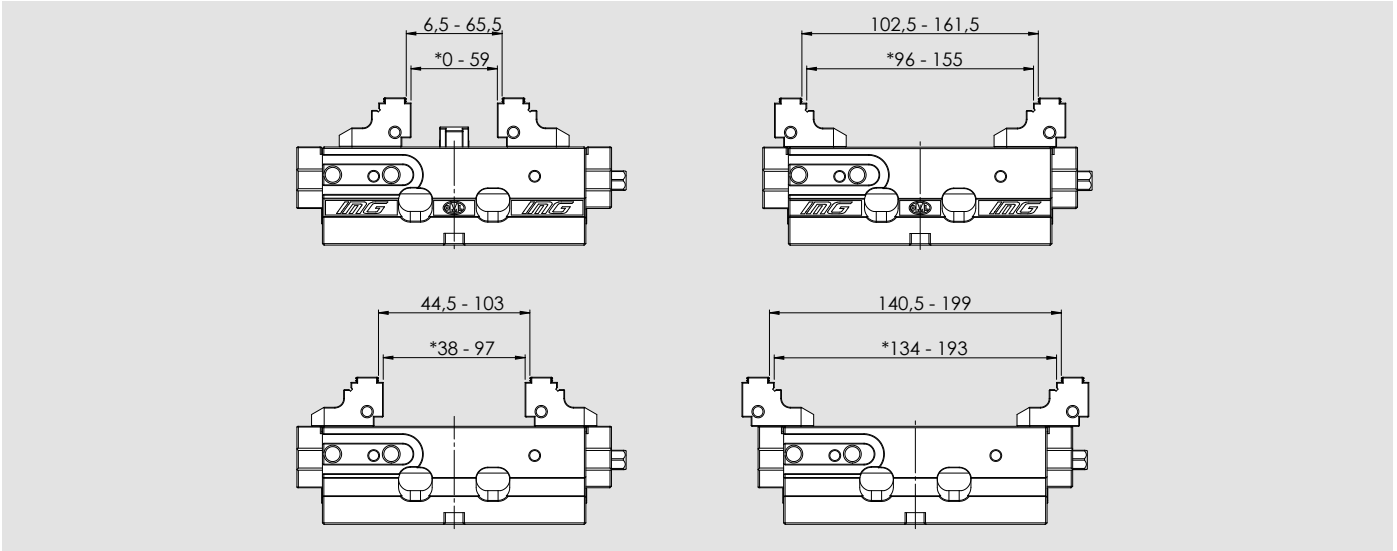

Double Clamping

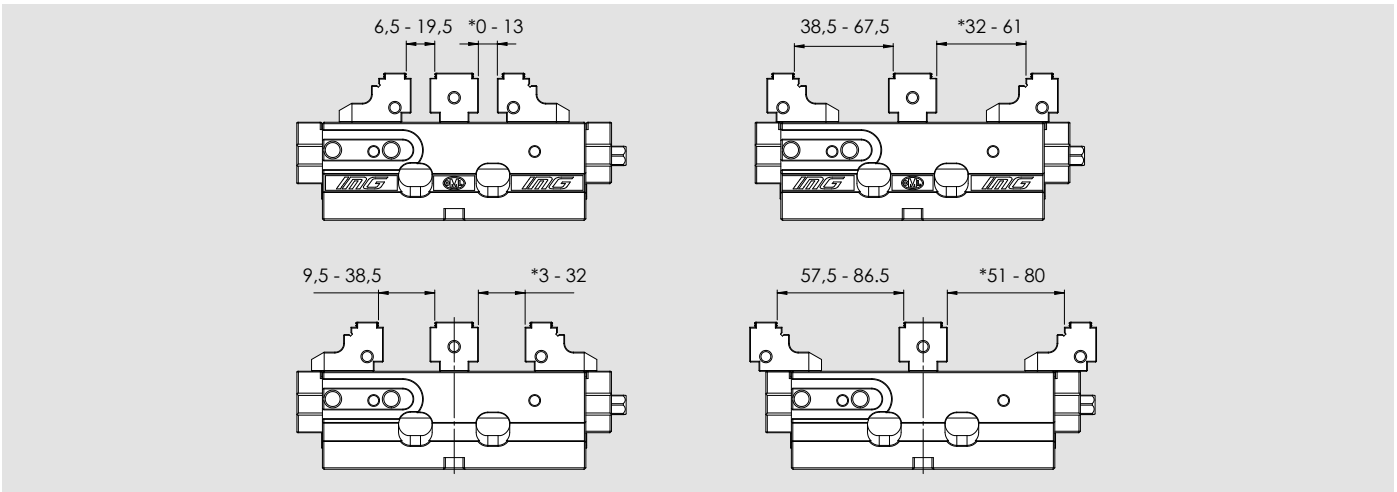

Fixed

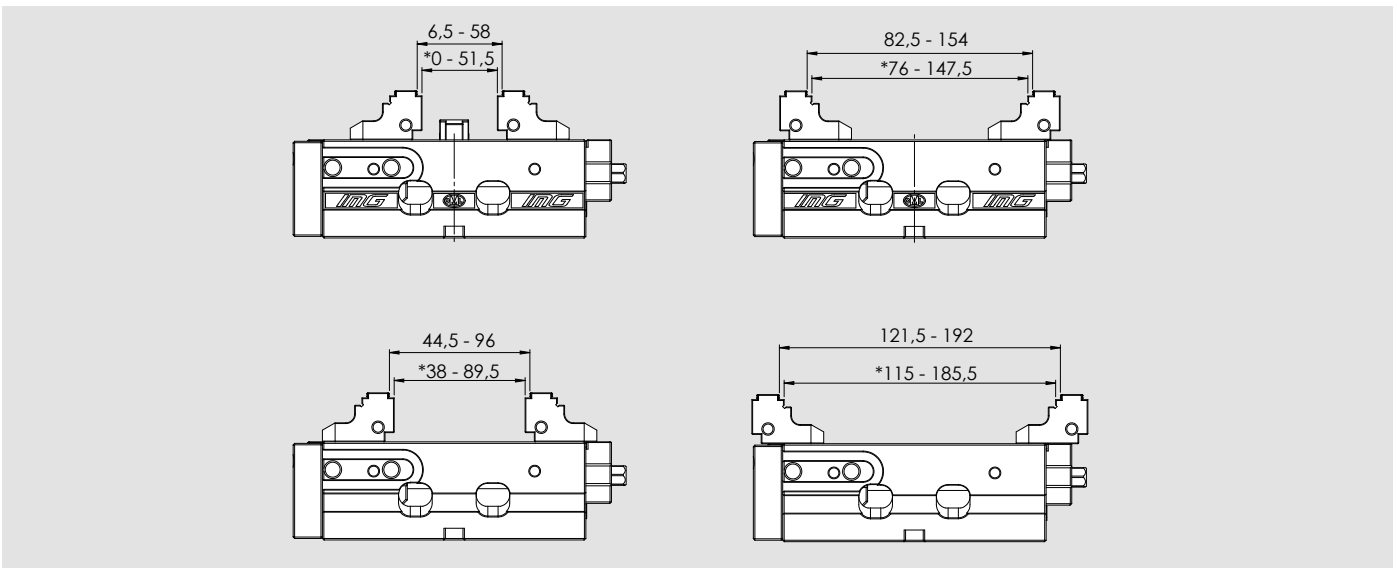

\* Opening with smooth jaws

Valid dimensions for both SinterGrip and Basic type

# IMG 125 - 220

## Self-centering vice | Double Clamping | Fixed

■ Patented protected screw

### Applications / Customer Benefits

- Highly precise self-centering clamping with maximum repeatability
- Totally protected
- Compact design for better accessibility and very large drainage slots
- Jaws with SinterGrip clamping inserts for minimum workpiece clamping depth without pre-machining
- Type **IMG BASIC** with jaws without SinterGrip inserts
- Wide clamping range
- Ideal for OP 10 and OP 20

### Technical features

- Self-centering clamping
- Clamping force up to 40 kN (80 Nm)
- Jaw width 125 mm
- Interface for zero point systems APS / TDM and Lang 52 / 96 mm as standard

### Standard equipment

Wrench, jaws, Sintergrip inserts.

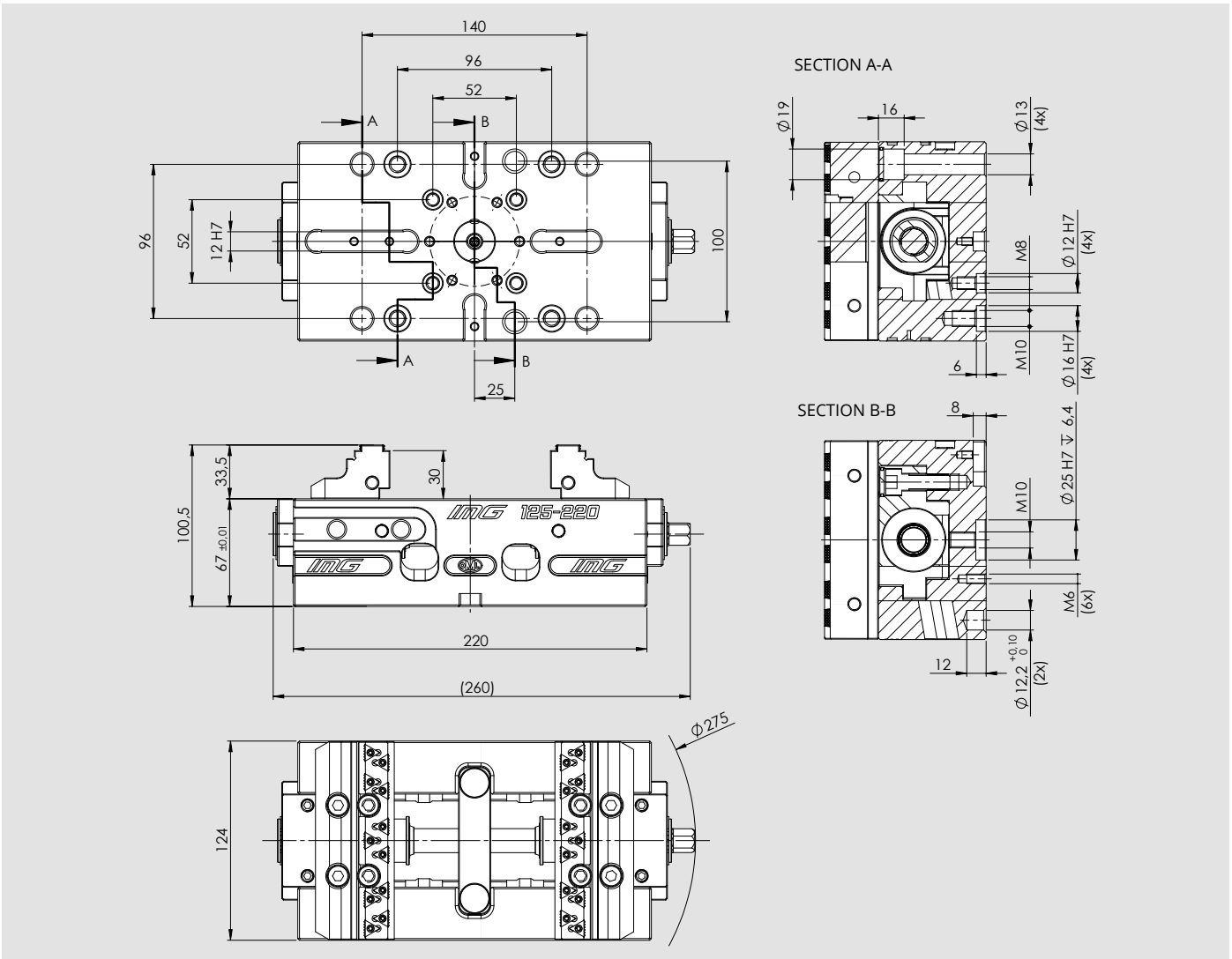

Type	Id. No.	Weight
IMG 125 - 220 with SinterGrip jaws <b>STD</b>	77583511	15 Kg
IMG 125 - 220 with SinterGrip jaws <b>ALU</b>	77583512	15 Kg
IMG 125 - 220 with SinterGrip jaws <b>HRC</b>	77583513	15 Kg
IMG 125 - 220 <b>Basic</b>	77583514	15 Kg
IMG 125 - 220 body only	77583501	13 Kg



■ Patented protected screw

Self-centering

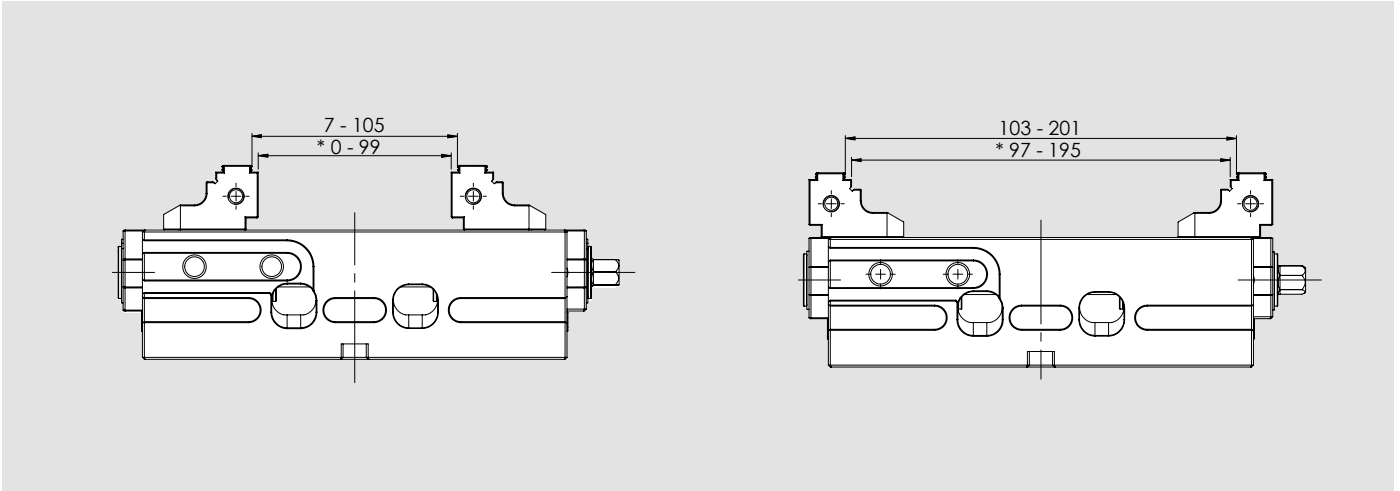

Double Clamping

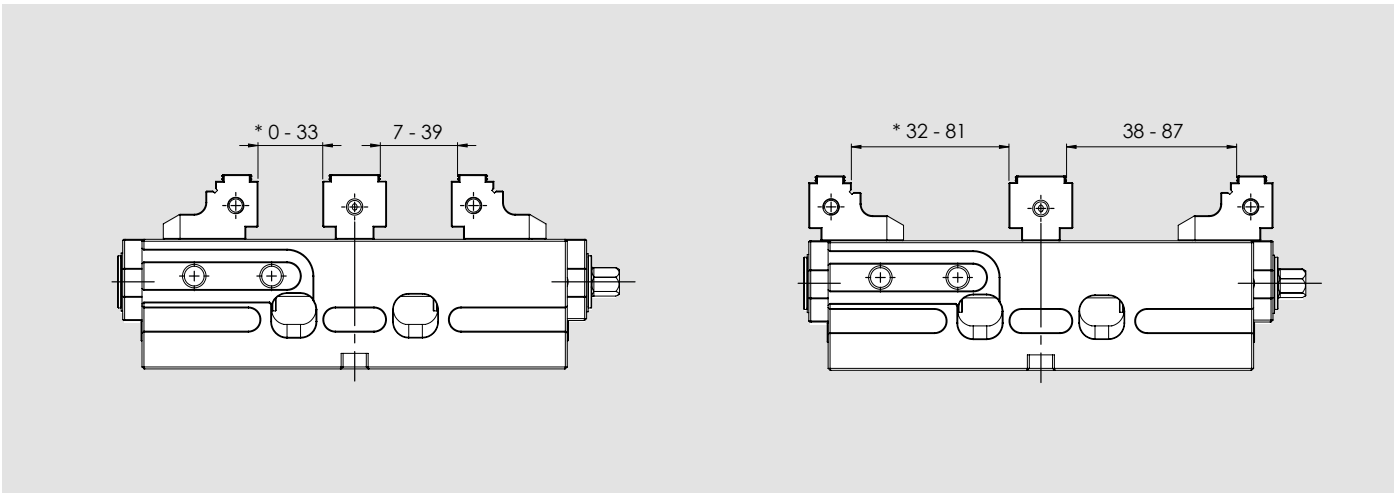

Fixed

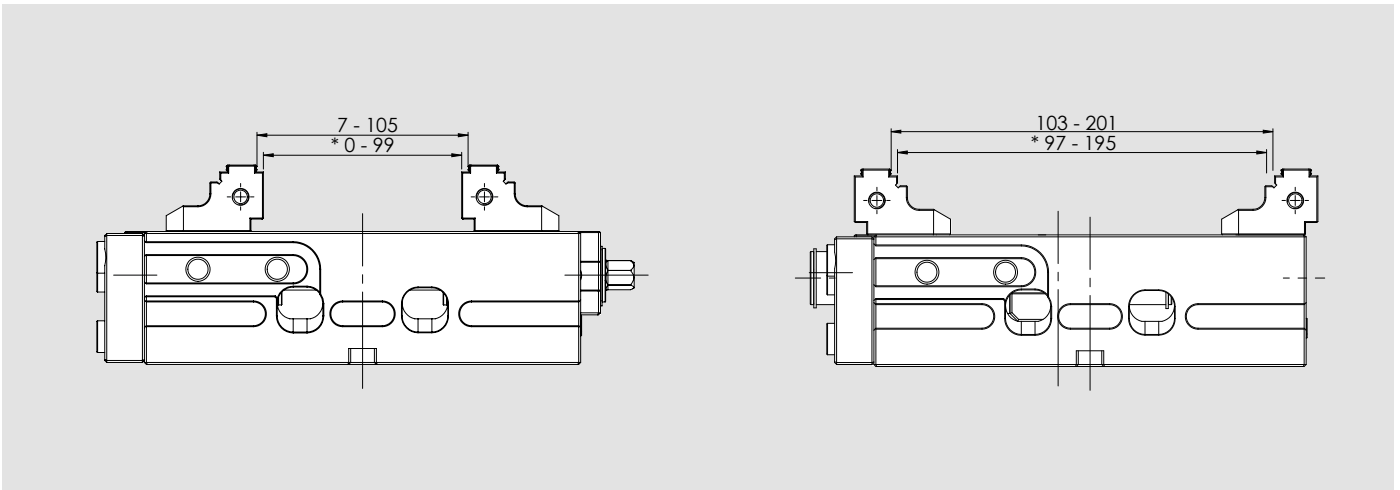

\* Opening with smooth jaws

Valid dimensions for both SinterGrip and Basic type

# IMG 125 - 320

## Self-centering vice | Double Clamping | Fixed

■ Patented protected screw



### Applications / Customer Benefits

- Highly precise self-centering clamping with maximum repeatability
- Totally protected
- Compact design for better accessibility and very large drainage slots
- Jaws with SinterGrip clamping inserts for minimum workpiece clamping depth without pre-machining
- Type **IMG BASIC** with jaws without SinterGrip inserts
- Wide clamping range
- Ideal for OP 10 and OP 20

### Technical features

- Self-centering clamping
- Clamping force up to 40 kN (80 Nm)
- Jaw width 125 mm
- Interface for zero point systems APS / TDM and Lang 96 mm as standard

### Standard equipment

Wrench, jaws, Sintergrip inserts.

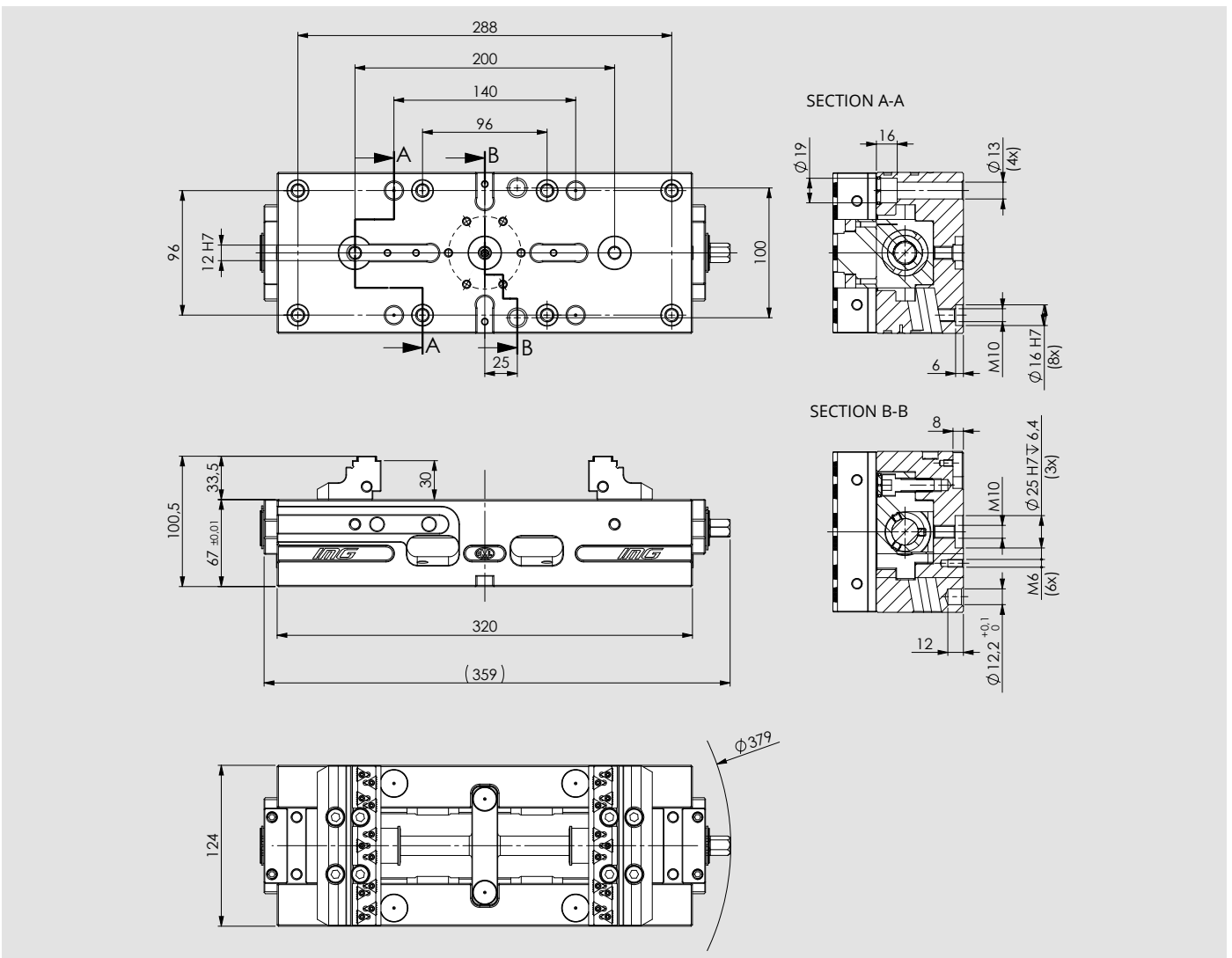

Type	Id. No.	Weight
IMG 125 - 320 with SinterGrip jaws <b>STD</b>	77583521	20 Kg
IMG 125 - 320 with SinterGrip jaws <b>ALU</b>	77583522	20 Kg
IMG 125 - 320 with SinterGrip jaws <b>HRC</b>	77583523	20 Kg
IMG 125 - 320 <b>Basic</b>	77583524	20 Kg
IMG 125 - 320 body only	77583502	18 Kg

■ Patented protected screw

Self-centering

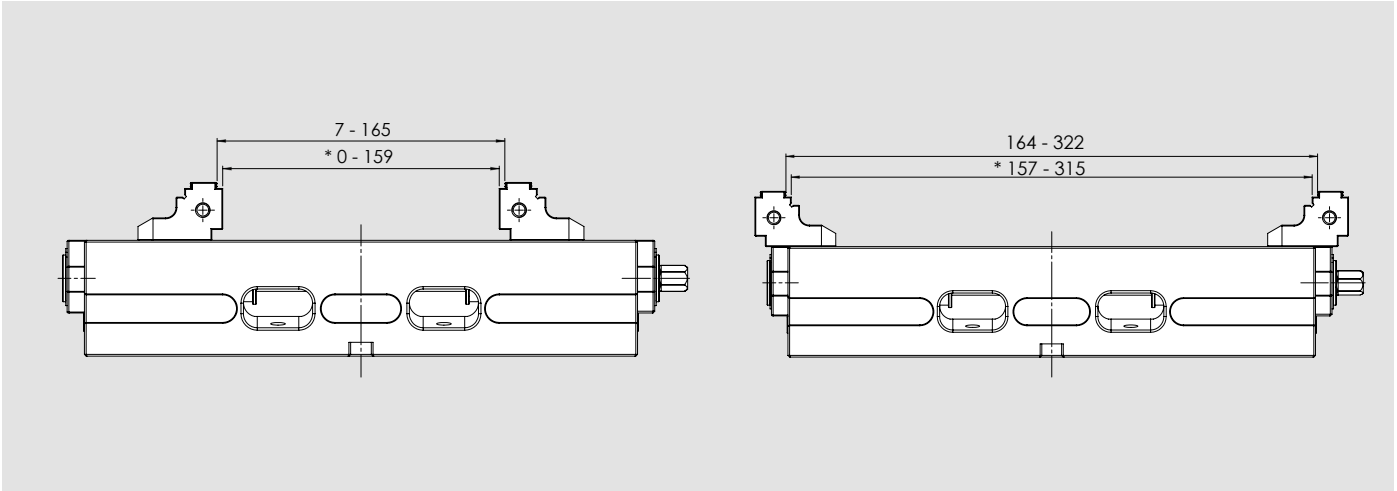

Double Clamping

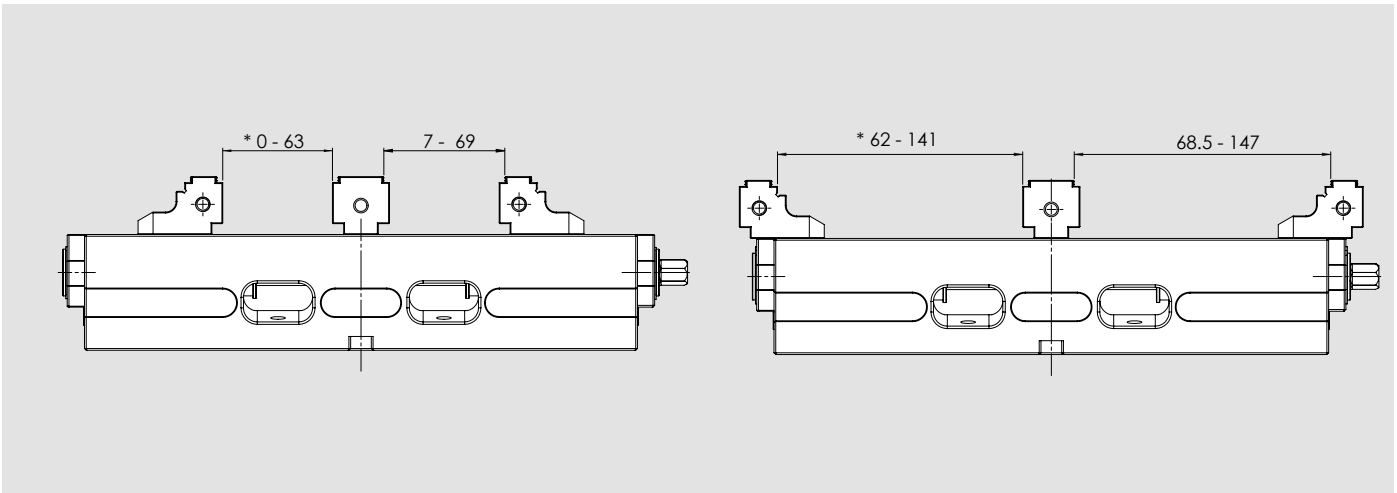

Fixed

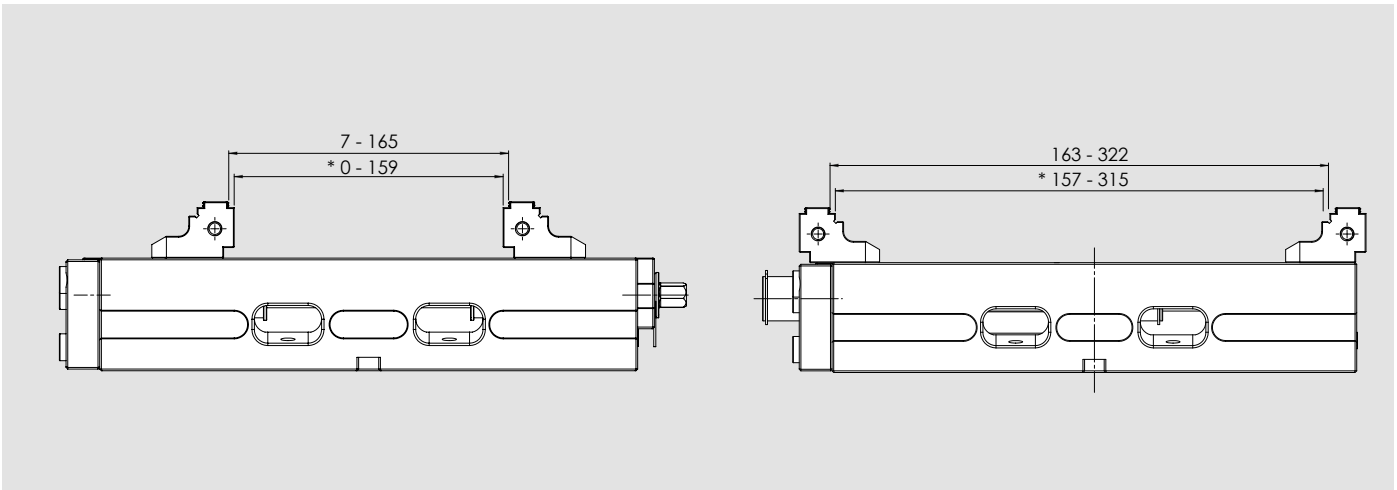

\* Opening with smooth jaws

Valid dimensions for both SinterGrip and Basic type

■ Patented protected screw



### Applications / Customer Benefits

- Highly precise self-centering clamping with maximum repeatability
- Totally protected
- Compact design for better accessibility and very large drainage slots
- Jaws with SinterGrip clamping inserts for minimum workpiece clamping depth without pre-machining
- Type **IMG BASIC** with jaws without SinterGrip inserts
- Wide clamping range
- Ideal for OP 10 and OP 20

### Technical features

- Self-centering clamping
- Clamping force up to 50 kN (100 Nm)
- Jaw width 160 mm
- Interface for zero point systems APS / TDM and Lang 96 mm as standard

### Standard equipment

Wrench, jaws, Sintergrip inserts.

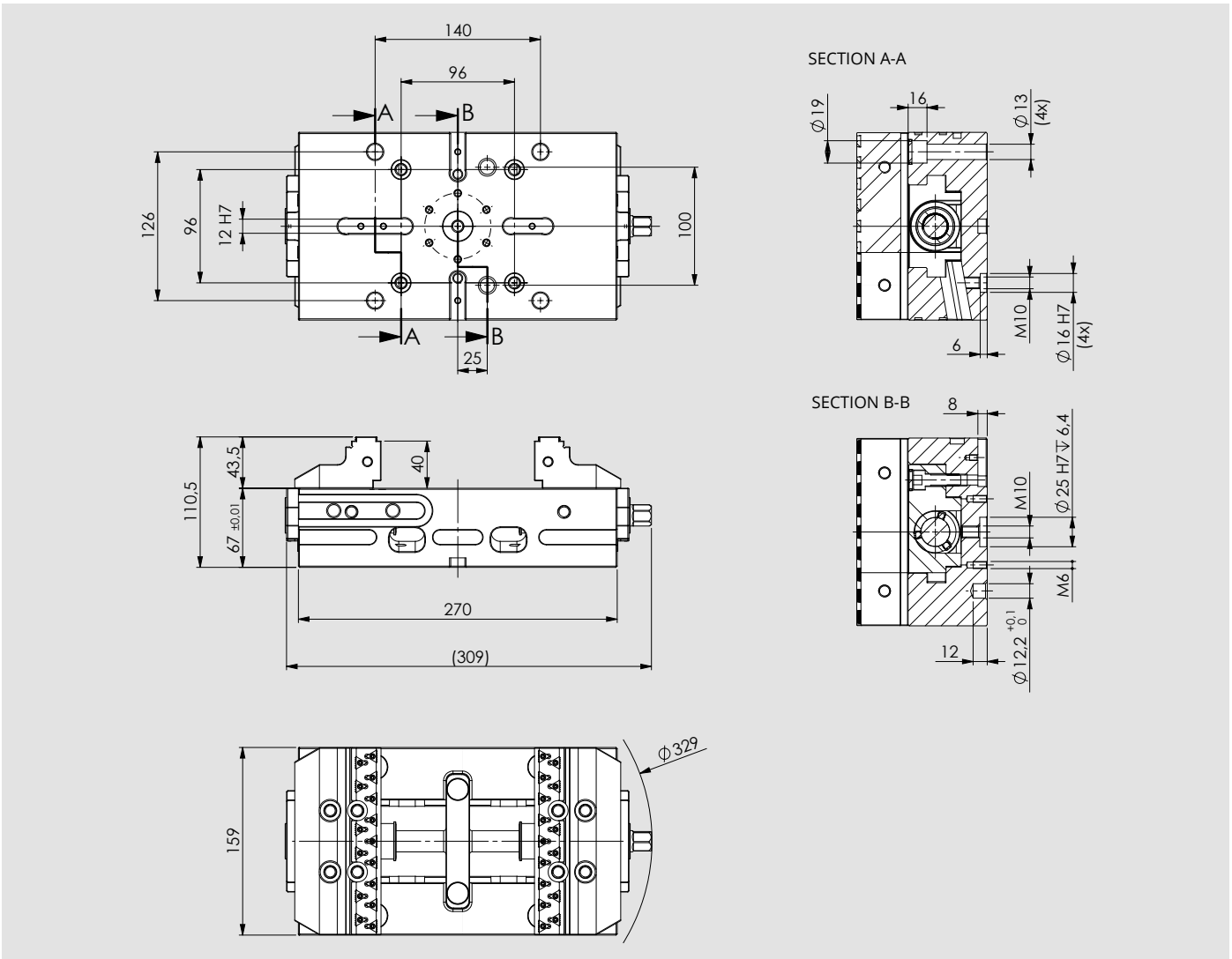

Type	Id. No.	Weight
IMG 160 - 270 with SinterGrip jaws <b>STD</b>	77583611	22 Kg
IMG 160 - 270 with SinterGrip jaws <b>ALU</b>	77583612	22 Kg
IMG 160 - 270 with SinterGrip jaws <b>HRC</b>	77583613	22 Kg
IMG 160 - 270 <b>Basic</b>	77583614	22 Kg
IMG 160 - 270 body only	77583601	17 Kg

■ Patented protected screw

Self-centering

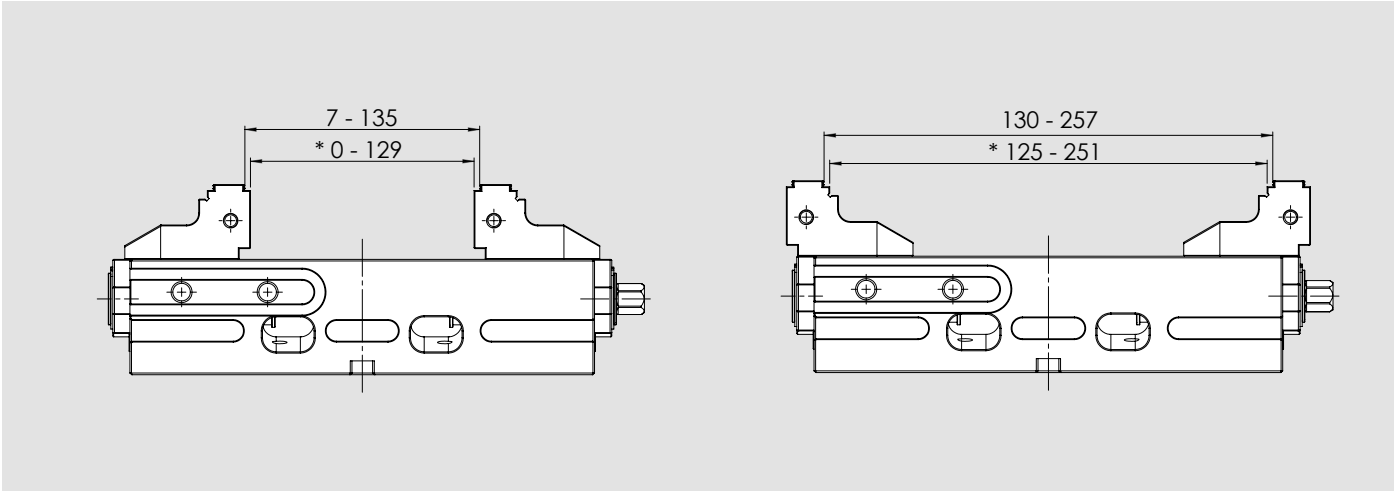

Double Clamping

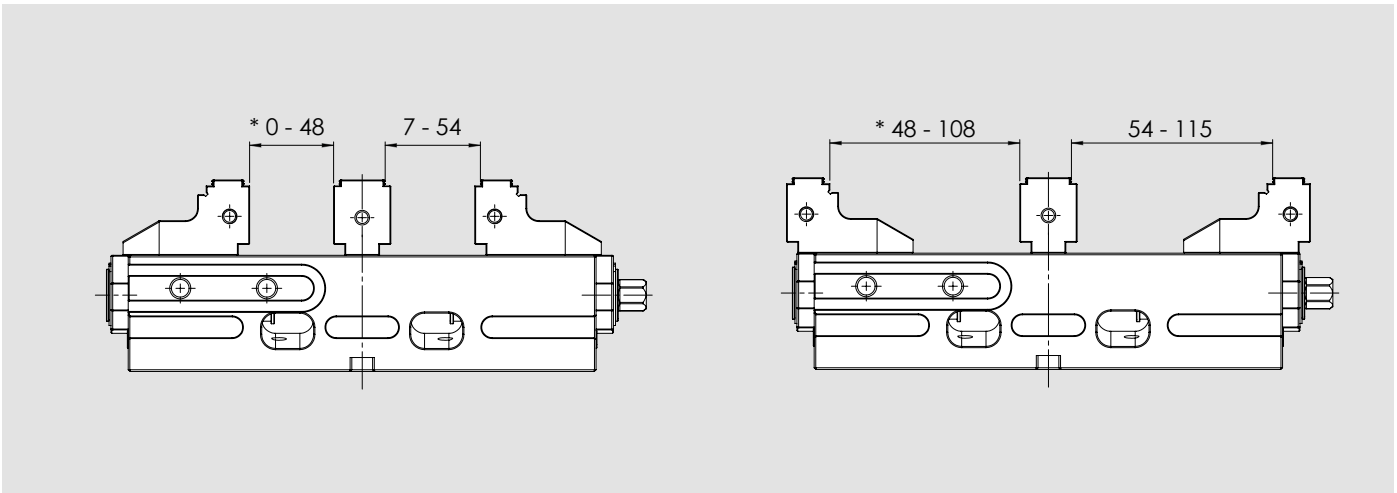

Fixed

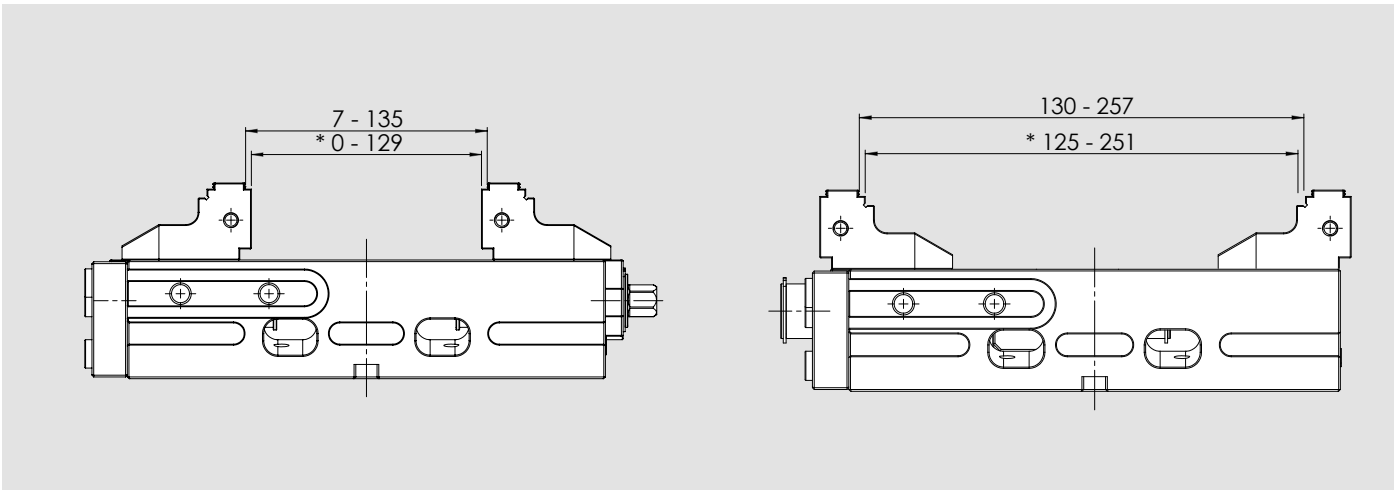

\* Opening with smooth jaws

Valid dimensions for both SinterGrip and Basic type



# IMG 160 - 420

## Self-centering vice | Double Clamping | Fixed

■ Patented protected screw

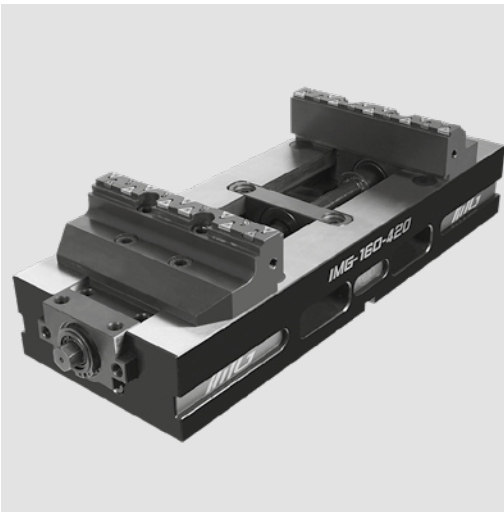

### Applications / Customer Benefits

- Highly precise self-centering clamping with maximum repeatability
- Totally protected
- Compact design for better accessibility and very large drainage slots
- Jaws with SinterGrip clamping inserts for minimum workpiece clamping depth without pre-machining
- Type **IMG BASIC** with jaws without SinterGrip inserts
- Wide clamping range
- Ideal for OP 10 and OP 20

### Technical features

- Self-centering clamping
- Clamping force up to 50 kN (100 Nm)
- Jaw width 160 mm
- Interface for zero point systems APS / TDM and Lang 96 mm as standard

### Standard equipment

Wrench, jaws, Sintergrip inserts.

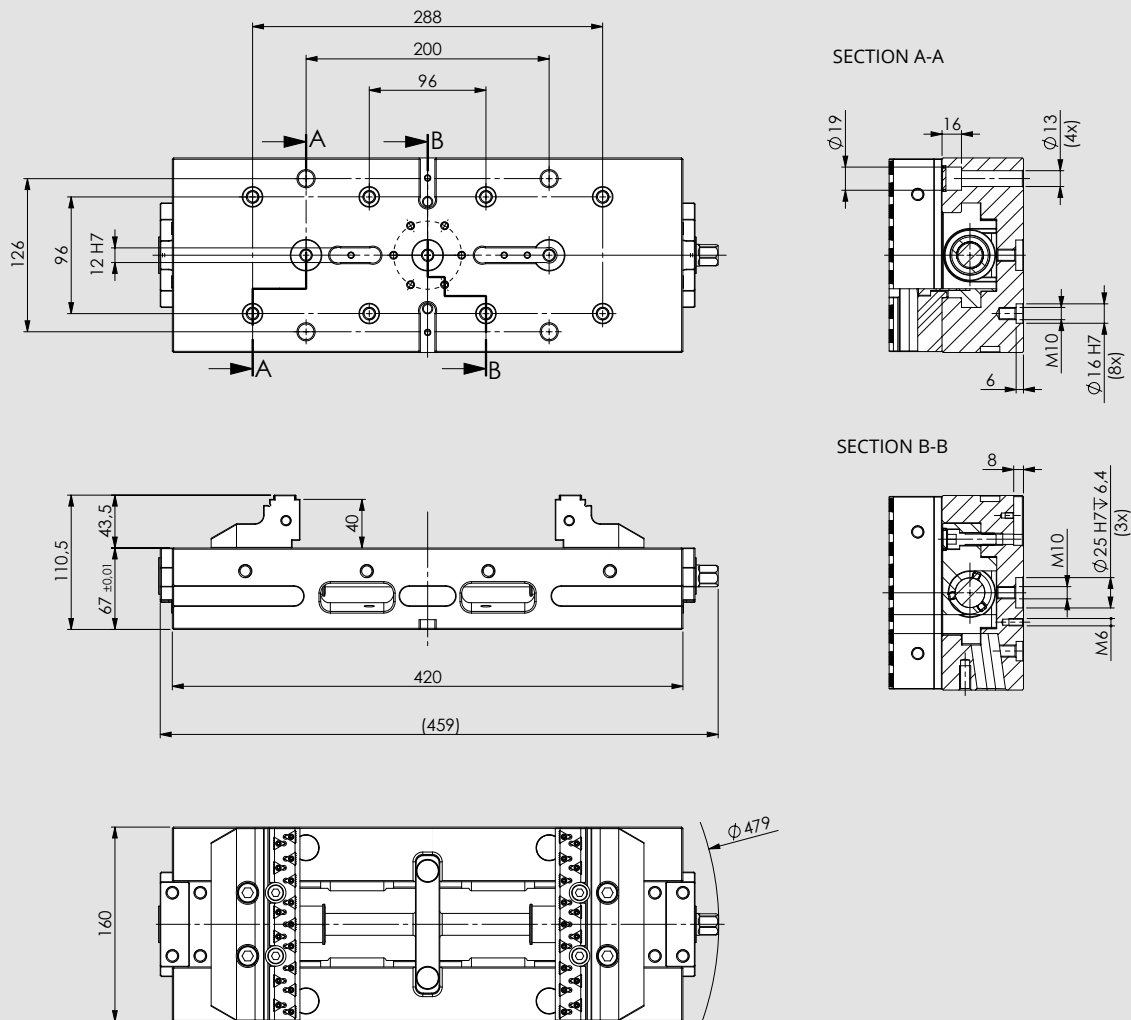

Type	Id. No.	Weight
IMG 160 - 420 with SinterGrip jaws <b>STD</b>	77583621	32 Kg
IMG 160 - 420 with SinterGrip jaws <b>ALU</b>	77583622	32 Kg
IMG 160 - 420 with SinterGrip jaws <b>HRC</b>	77583623	32 Kg
IMG 160 - 420 <b>Basic</b>	77583624	32 Kg
IMG 160 - 420 body only	77583602	27 Kg

■ Patented protected screw

Self-centering

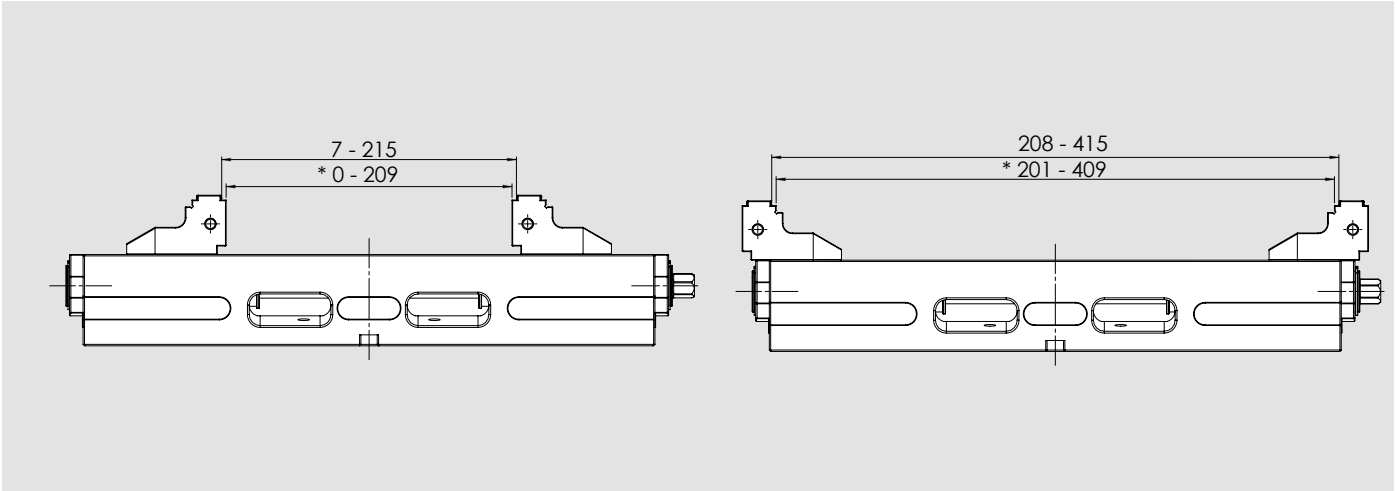

Double Clamping

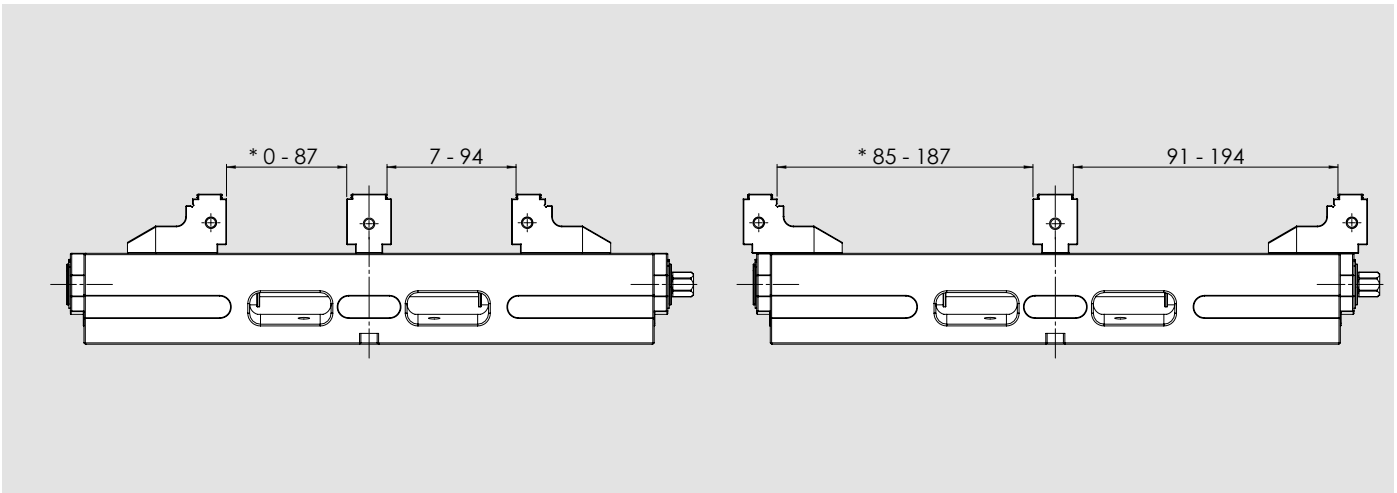

Fixed

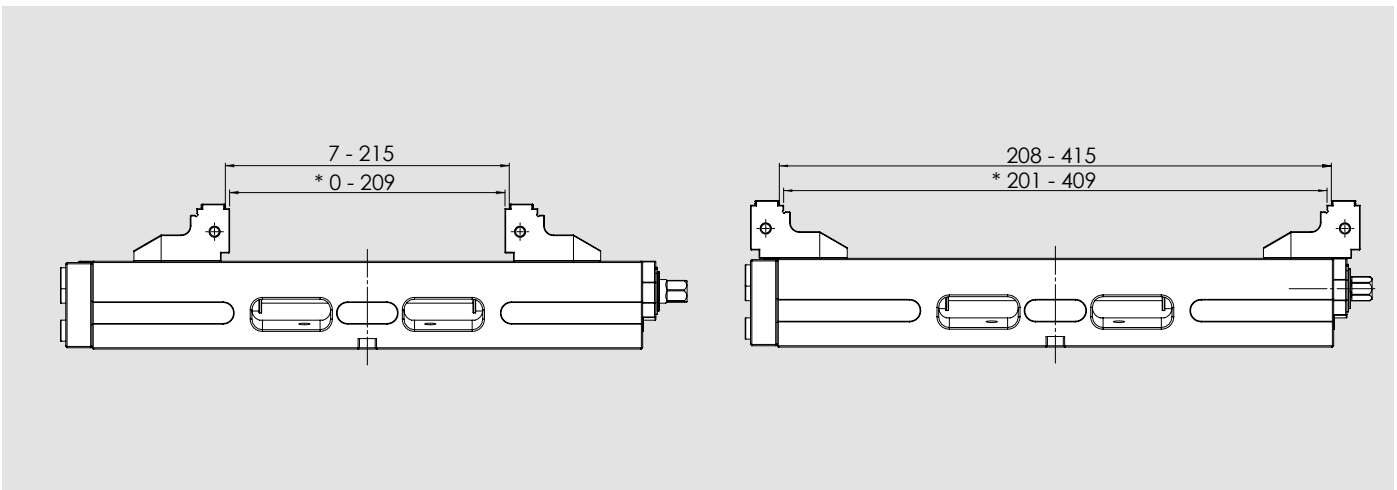

\* Opening with smooth jaws

Valid dimensions for both SinterGrip and Basic type

**Double clamping jaw (SinterGrip not included, to be specified when ordering)**

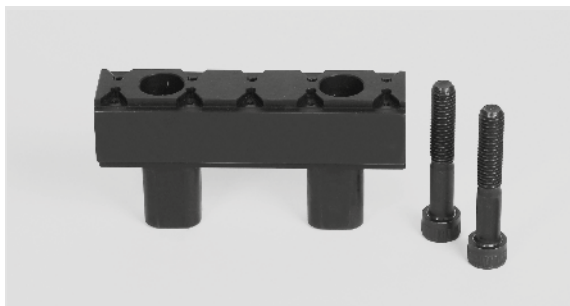

Type	Id. No.
IMG 88	58341719
IMG 125	58351719
IMG 160	58361719

**Double clamping smooth jaw**

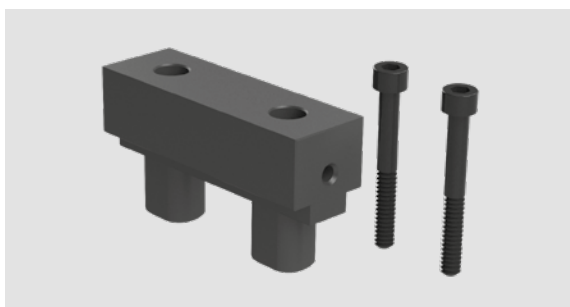

Type	Id. No.
IMG 88	58341739
IMG 125	58351739
IMG 160	58361739

**Double clamping jaw BASIC**



Type	Id. No.
IMG 88	58341759
IMG 125	58351759
IMG 160	58361719

**Reduced double clamping jaw (SinterGrip not included, to be specified when ordering)**

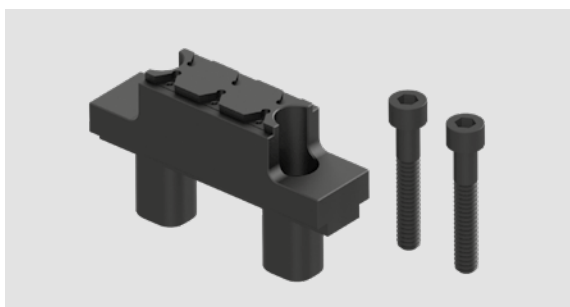

Type	Id. No.
IMG 88	58341729
IMG 125	58351729
IMG 160	58361729

**Retainer plate**



Type	Id. No.
IMG 88	58341019
IMG 125 - 180	58351039
IMG 125 - 220 / 320	58351019
IMG 160	58361019

Pair of smooth jaws

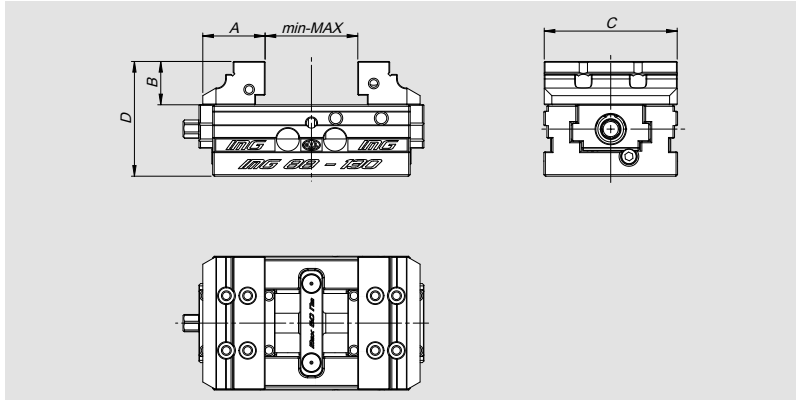
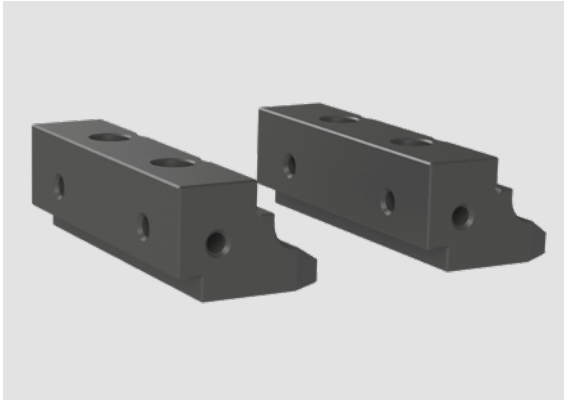

Type	Id. No.	A	B	C	D	min-max
IMG 88	58341819	41	28,5	87,5	75,5	see page 11
IMG 125	58351819	49	33,5	123,5	100,5	see page 13 / 15
IMG 160	58361819	73	43,5	158,5	110,5	see page 19 / 21

Pair of reduced jaws - SinterGrip not included, to be specified when ordering

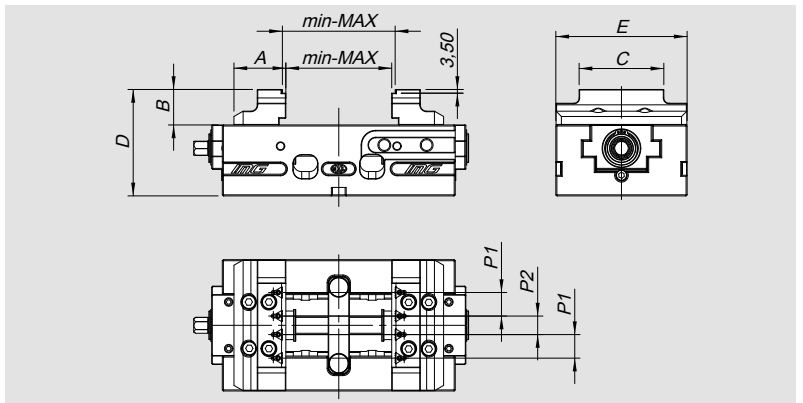
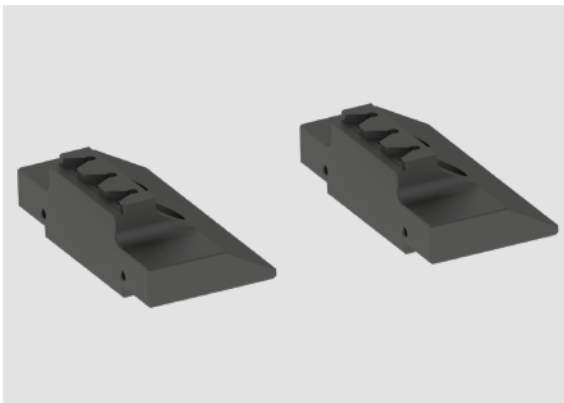

Type	Id. No.	A	B	C	D	E	p1	p2	min.	max.	n. seats
IMG 88 - 130	58341519	35	38,5	48	85,5	87,5	--	18	0 - 7	61 - 67,5	2
IMG 125 - 180	58351519	49	43,5	74	110,5	123,5	21,5	18	0 - 7	59 - 65,5	4
IMG 125 - 220	58351519	49	43,5	74	110,5	123,5	21,5	18	0 - 7	99 - 105	4
IMG 125 - 320	58351519	49	43,5	74	110,5	123,5	21,5	18	0 - 7	159 - 165	4
IMG 160 - 270	58361519	73	53,5	82	120,5	158,5	17	17	0 - 7	129 - 135	5
IMG 160 - 420	58361519	73	53,5	82	120,5	158,5	17	17	0 - 7	209 - 215	5

### Pair of soft jaws (soft steel – ALU)

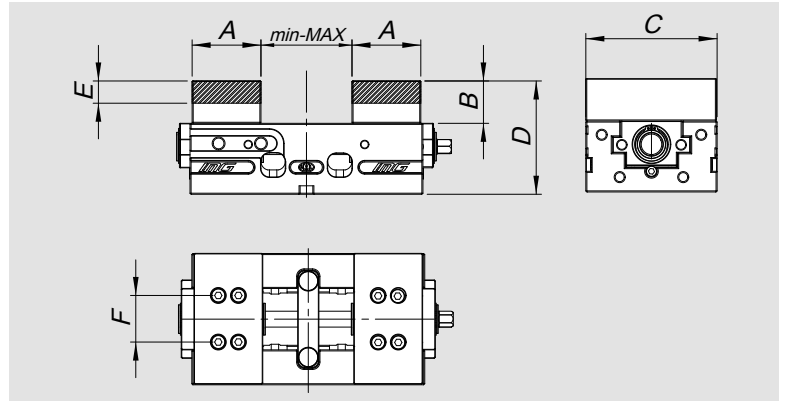
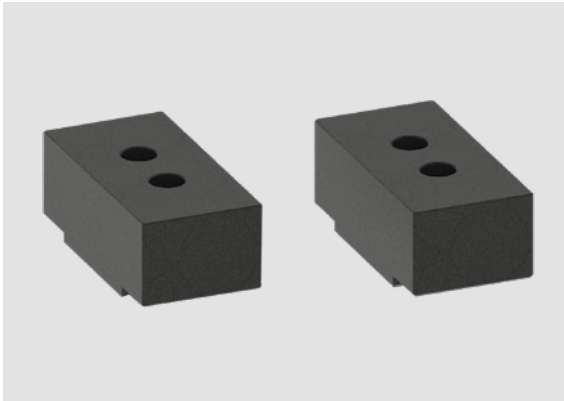

Type		Id. No.	A	B	C	D	E	F	min.	max.
IMG 88	ALU	58341619	45	40	87.5	87	23	36	0	54
IMG 88	Fe	58341629	45	40	87.5	87	23	36	0	54
IMG 125	ALU	58351619	65	40	123,5	107	20	44	0	86 (125x220) / 186 (125x320)
IMG 125	Fe	58351629	65	40	123,5	107	20	44	0	86 (125x220) / 186 (125x320)
IMG 160	ALU	58361619	85	50	158.5	117	25	52	0	141-147 (160x270) / 221-227 (160x420)
IMG 160	Fe	58361629	85	50	158.5	117	25	52	0	141-147 (160x270) / 221-227 (160x420)

### Set of soft jaws for double clamping

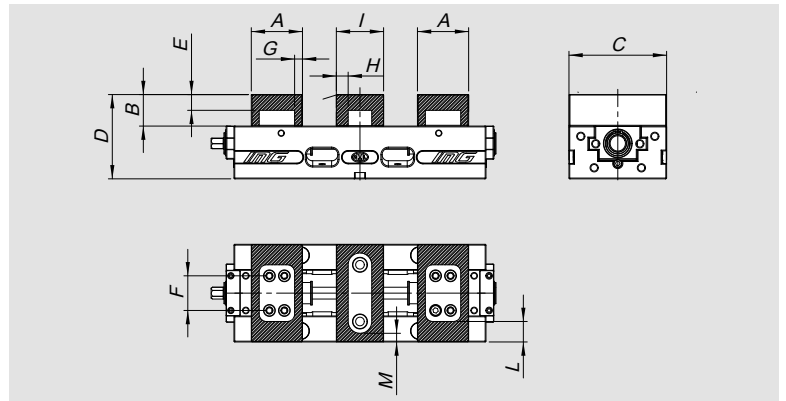
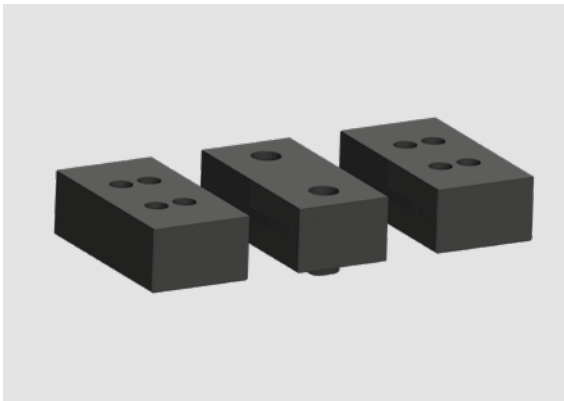

Type		Id. No.	A	B	C	D	E	F	G	H	I	L	M
IMG 125	ALU	58359519	65	40	123,5	107	20	44	10	15	60	25	11
IMG 125	Fe	58359619	65	40	123,5	107	20	44	10	15	60	25	11
IMG 160	ALU	58369519	85	50	158.5	117	25	52	16.5	15	60	35	28
IMG 160	Fe	58369619	85	50	158.5	117	25	52	16.5	15	60	35	28

### Application example

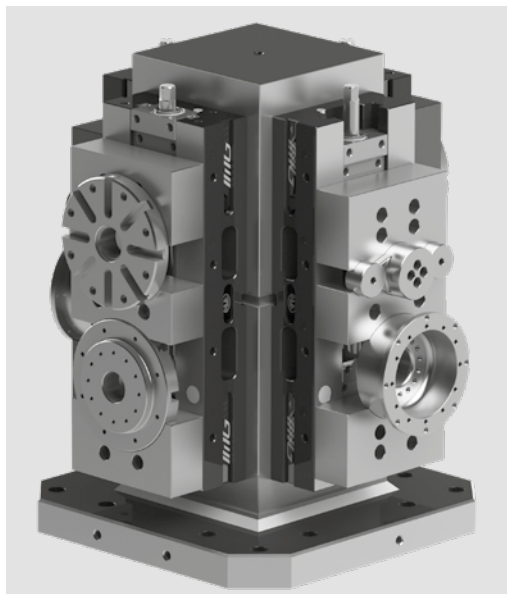



## OP10 - OP20 Kit double clamping

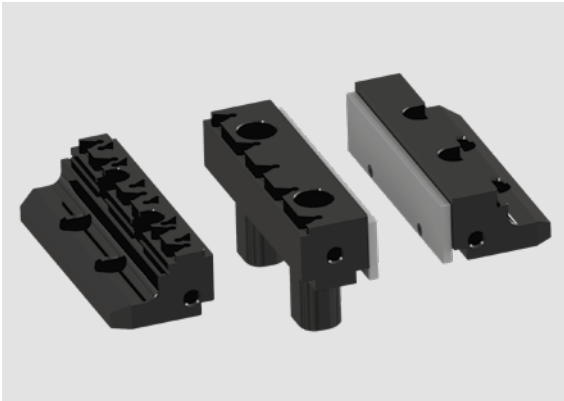

Type	Id. No.
IMG 88	58349719
IMG 125	58359719
IMG 160	58369719

## Application example

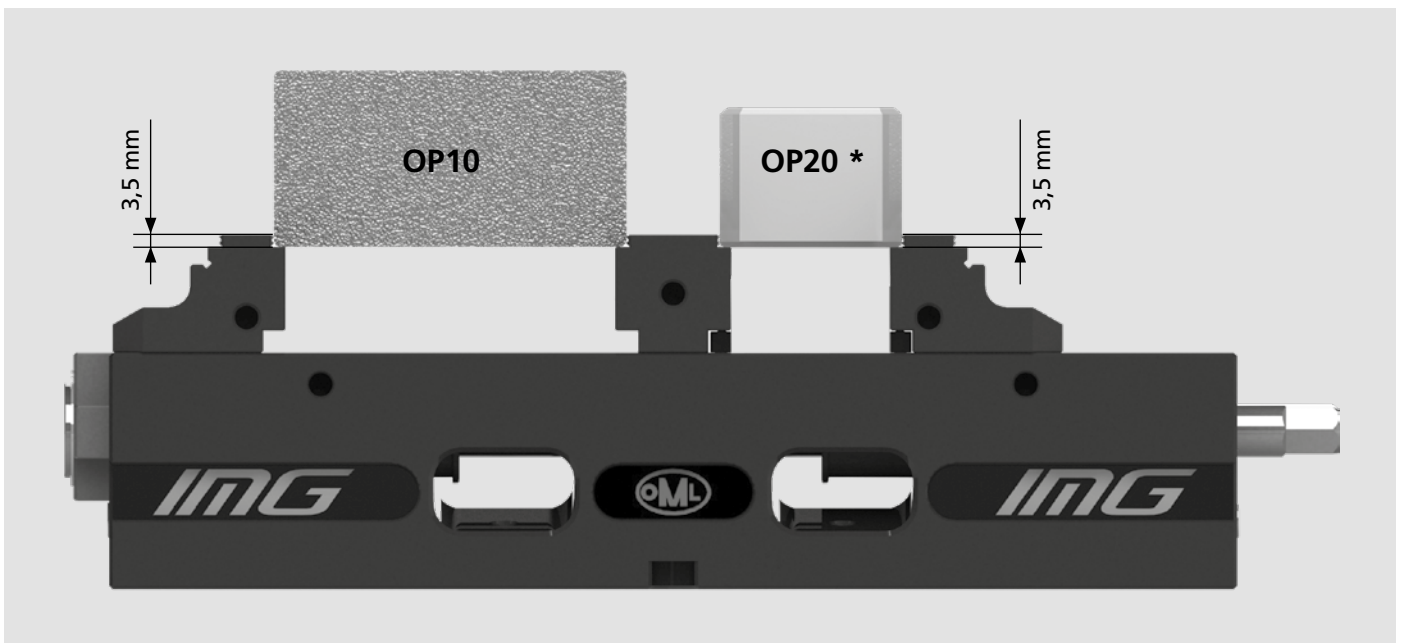

\* **OP20** with smooth jaws and parallels CLAK System.

### Applications / Customer Benefits

- Ideal for 5 axis machines
- Compact design
- Possibility to be mounted directly on machine tools with T slots
- Possibility to be mounted directly on single plate or DUO APS (pitch 200)

### Technical features

- Material: steel

### Standard equipment

On request: Positioning keys for IMG / APS pins / Positioning keys for machine tool

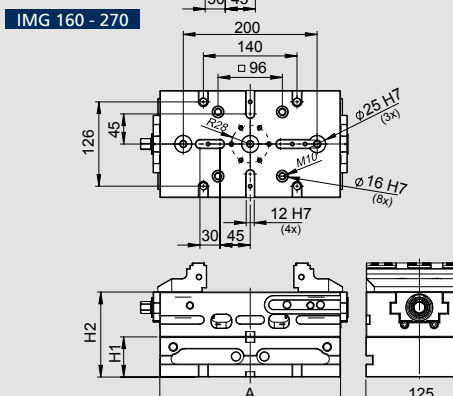
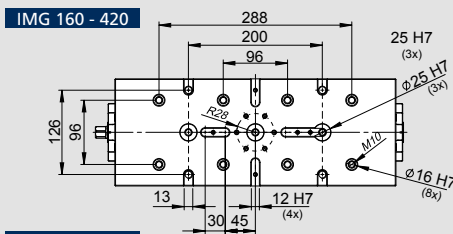
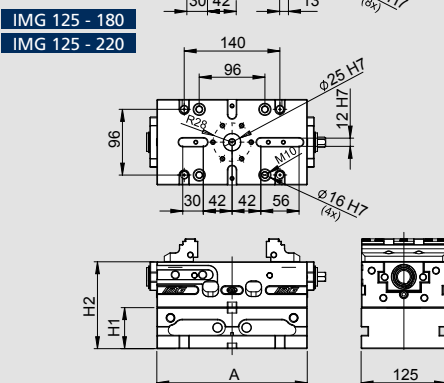
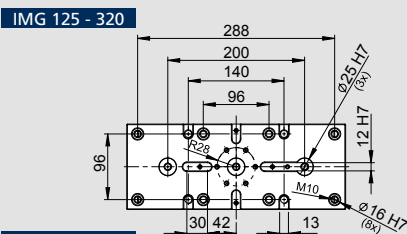
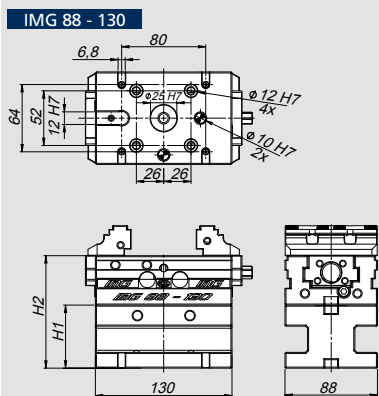
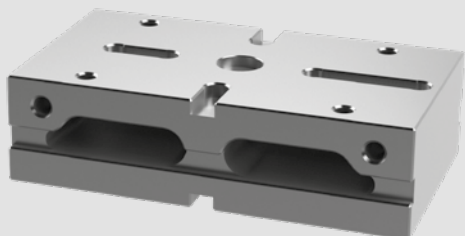

Type	Id. No.	H1	H2	A	Weight
For IMG 88 - 130	58342018	60	107	130	4 Kg
For IMG 88 - 130	58342028	100	207	130	6 Kg
For IMG 125 - 180	58352017	60	124	180	8 Kg
For IMG 125 - 180	58352027	100	147	180	12 Kg
For IMG 125 - 220	58352018	60	127	220	10 Kg
For IMG 125 - 220	58352028	100	167	220	15 Kg
For IMG 125 - 320	58352019	60	127	320	15 Kg
For IMG 125 - 320	58352029	100	167	320	21 Kg
For IMG 160 - 270	58362018	60	127	270	17 Kg
For IMG 160 - 270	58362028	100	167	270	25 Kg
For IMG 160 - 420	58362019	60	127	420	26 Kg
For IMG 160 - 420	58362029	100	167	420	38 Kg

### Application example

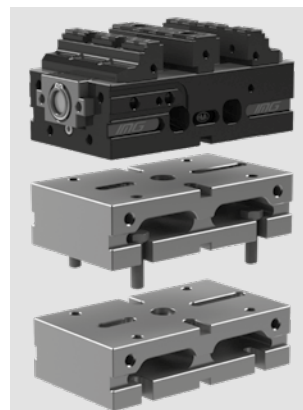
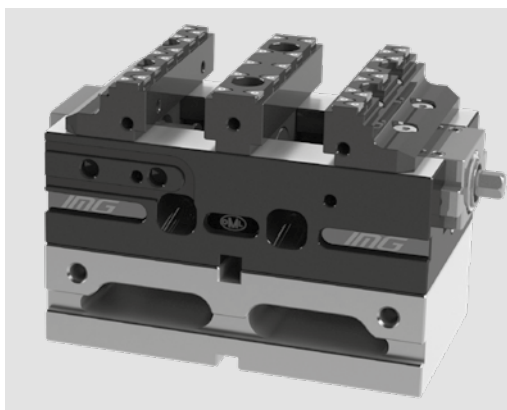

Floating jaw gripper

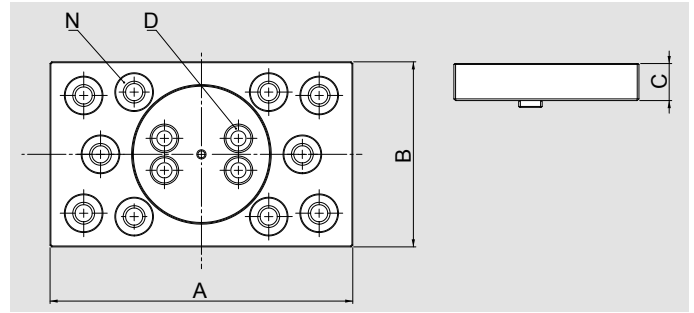
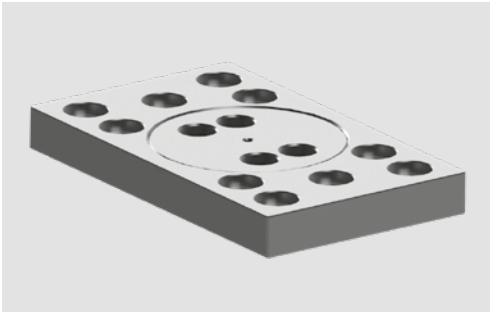

Type	Id. No.	A (mm)	B (mm)	D (mm)	N	C (mm)	Weight (Kg)
IMG 125	58352520	180	110	M8	10	22	3,100
IMG 160	58362520	200	120	M10	10	22	2,700

Fixed/movable jaw gripper

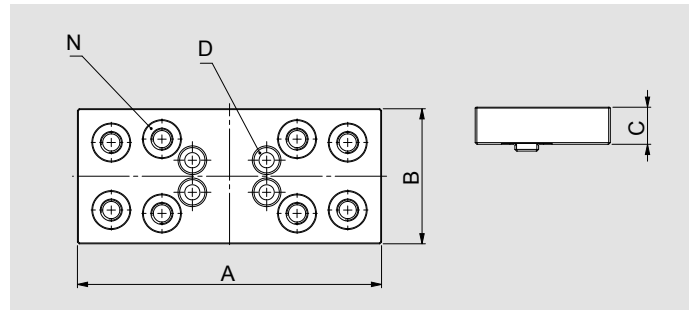
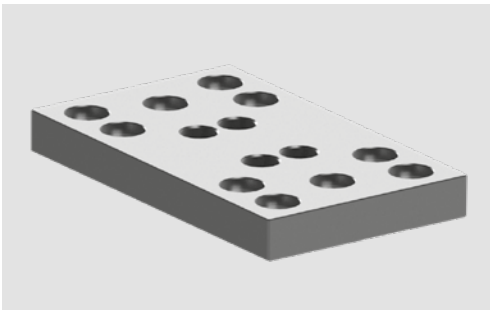

Type	Id. No.	A (mm)	B (mm)	D (mm)	N	C (mm)	Weight (Kg)
IMG 125	58352510	180	80	M10	8	22	2,300
IMG 160	58362510	200	90	M10	8	22	3,700

Fixed jaw for double clamping gripper

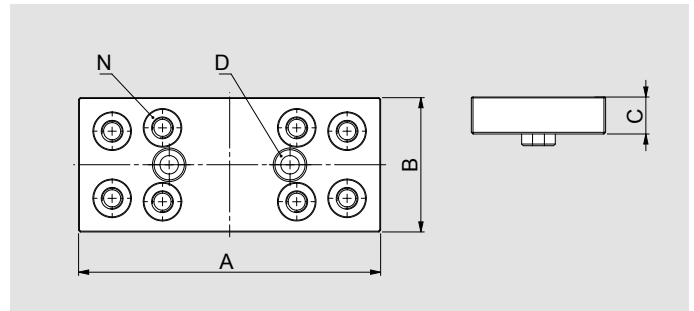
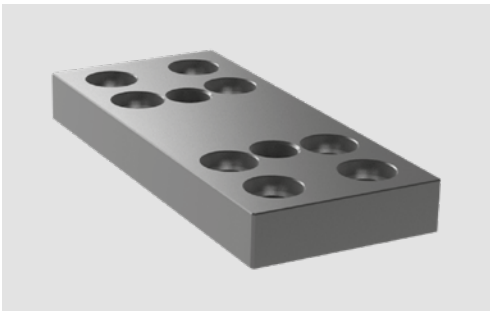

Type	Id. No.	A (mm)	B (mm)	D (mm)	N	C (mm)	Weight (Kg)
IMG 125	58352530	180	80	M8	8	22	2,300
IMG 160	58362530	200	120	M10	10	22	2,900

Application example

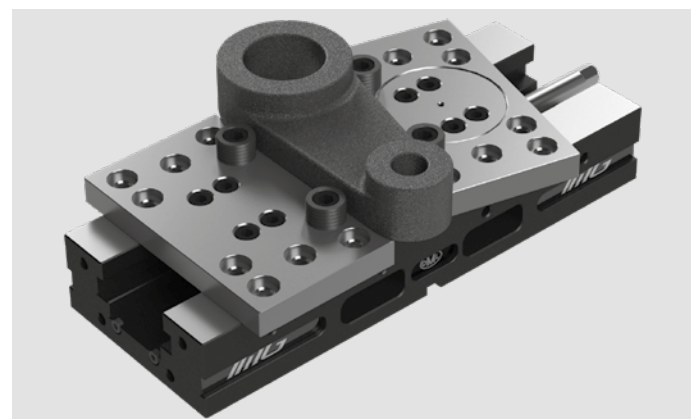

### Pair of supports with pull down jaws



Type	Id. No.	Weight (Kg)
IMG 125	58351419	4,100
IMG 160	58361419	8,300

### Pair of grooved jaws

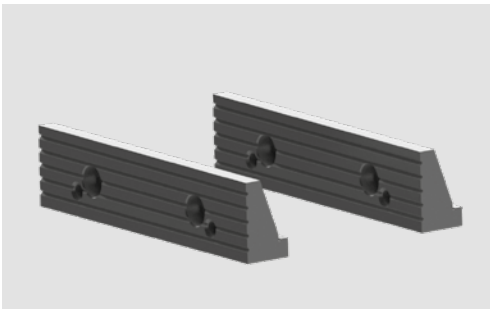

Type	Id. No.	Weight (Kg)
IMG 125	58351425	0,600
IMG 160	58361425	1,400

### Pair of smooth jaws

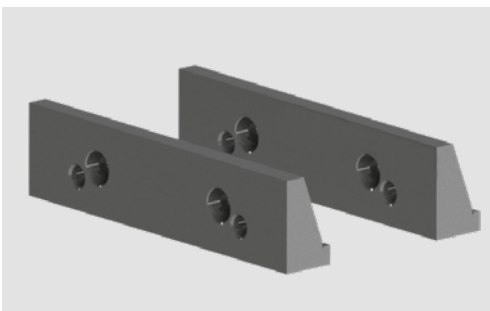

Type	Id. No.	Weight (Kg)
IMG 125	58351415	0,600
IMG 160	58361415	1,450

### Application example

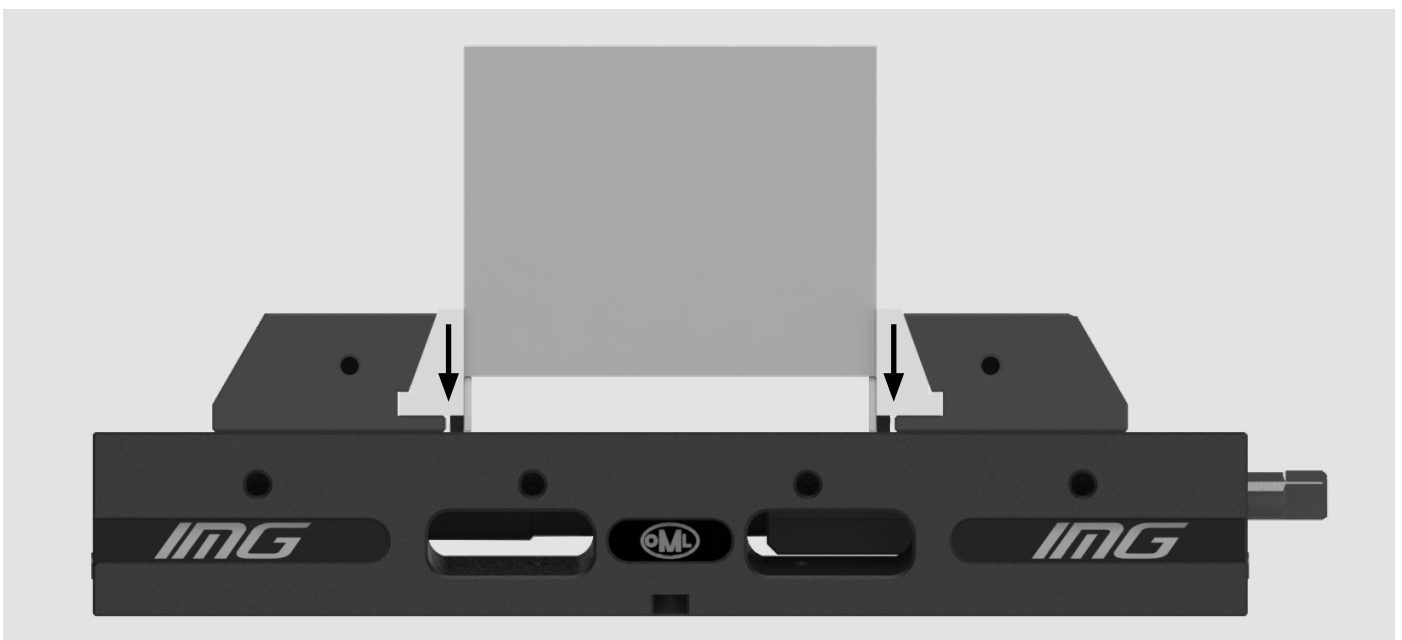

Floating jaws dimensions

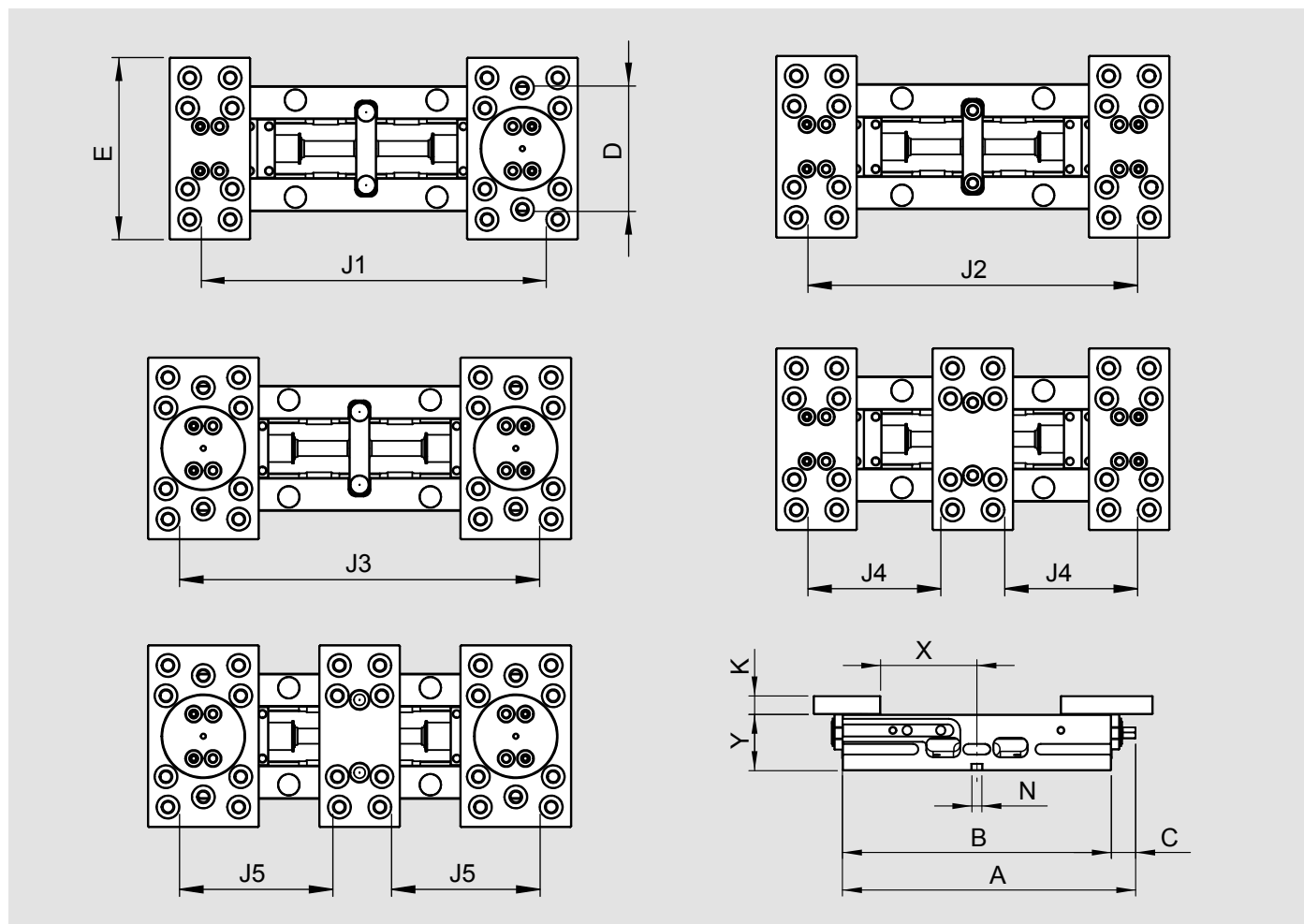

	A	B	C	D	E	K	N	X	Y	J1	J2	J3	J4	J5
IMG 125-220	247	220	27	124	180	22	12	54	67	215	200	230	65,5	X
IMG 125-320	349	320	29	124	180	22	12	115	67	335	349	350	125,5	140,5
IMG 160-270	299	270	29	159	200	22	12	59,5	67	290	290	290	105,5	105,5
IMG 160-420	449	420	29	160	200	22	12	150	67	448	448	448	184,5	184,5

Pull down jaws dimensions

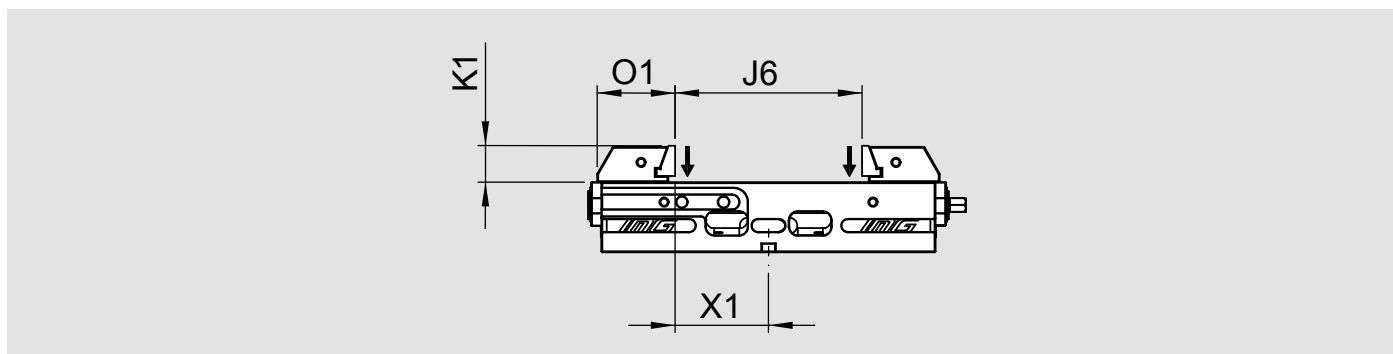

	K1	O1	X1	J6
IMG 125-220	35	74,4	59,5	119
IMG 125-320	35	74,4	119,5	239
IMG 160-270	45	91,5	76	152
IMG 160-420	45	91,5	155	310

### Maximum diameters of floating jaws

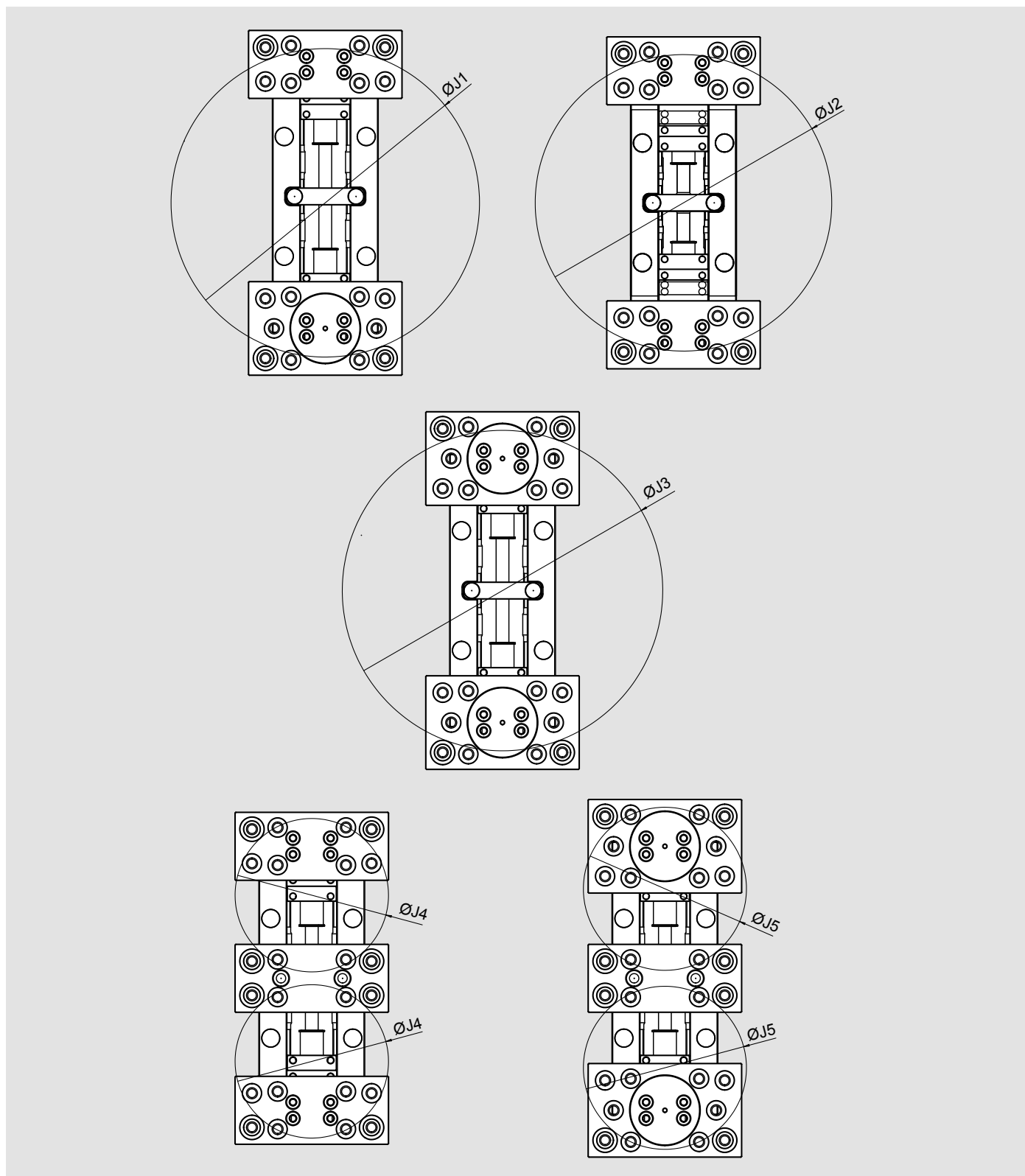

	Ø J1	Ø J2	Ø J3	Ø J4	Ø J5
IMG 125-220	252	239	265	122	X
IMG 125-320	360	347	375	179	190
IMG 160-270	327	327	327	180	180
IMG 160-420	441	441	441	224	224



Set of 4 grippers h11 smooth



**Id. No.**  
58906114

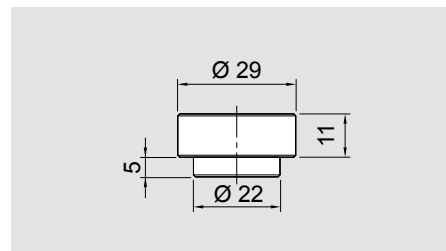

Set of 4 grippers h11 serrated



**Id. No.**  
58906124

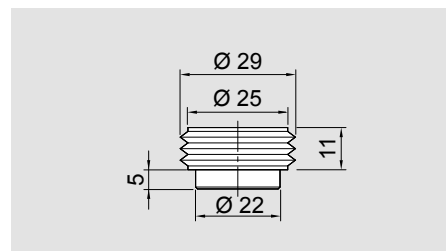

Set of 4 grippers h19 smooth



**Id. No.**  
58906214

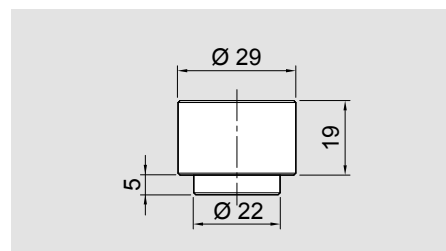

Set of 4 grippers h19 serrated



**Id. No.**  
58906224

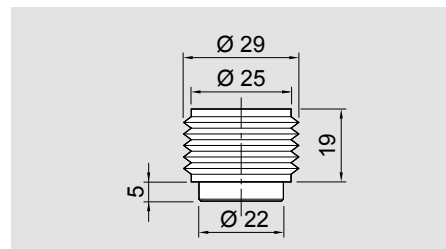

Set of 4 grippers h24 smooth



**Id. No.**  
58906314

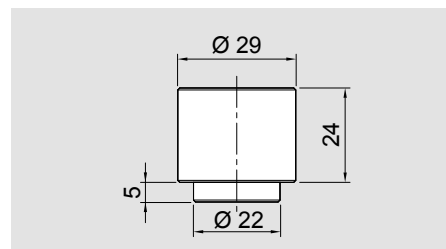

Set of 4 grippers h24 serrated



**Id. No.**  
58906324

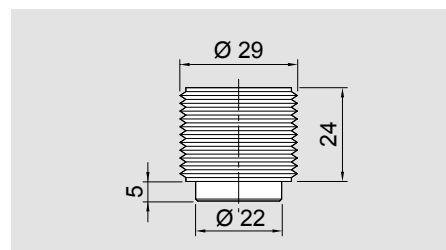

## Working examples

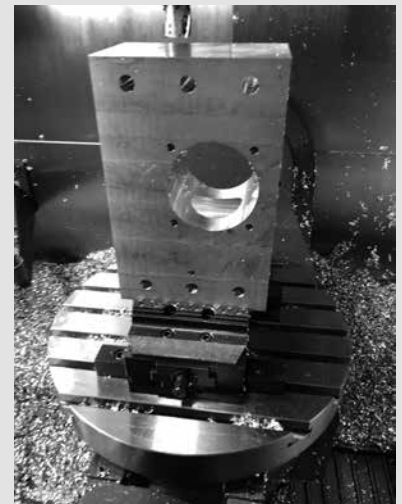
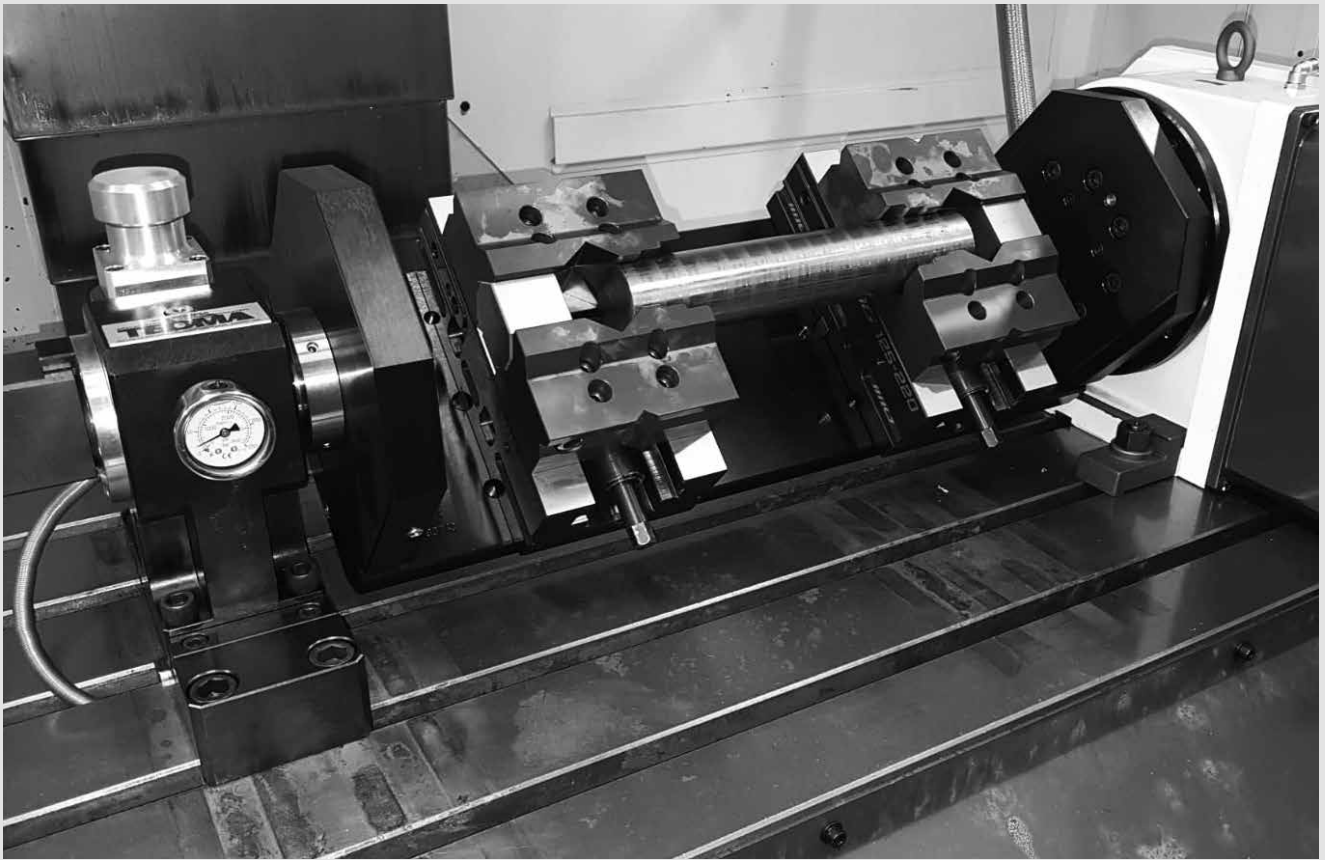

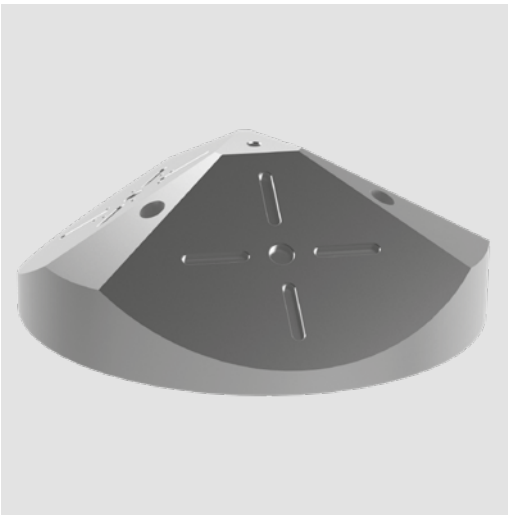

**Applications / Customer Benefits**

- Ideal for 5 axis machines
- Compact design
- Possibility to be mounted directly on machine tools with radial slots at 45 / 60 degrees
- Possibility to be mounted directly on single plate or DUO APS (pitch 200)

**Technical features**

- Material: ALU

**Standard equipment**

On request: Positioning keys for IMG / APS pins / Positioning keys for machine tool

IMG 88 - 130

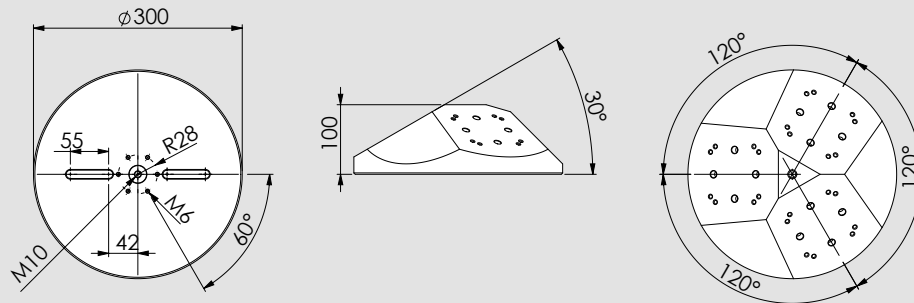

IMG 125 - 180

IMG 125 - 220

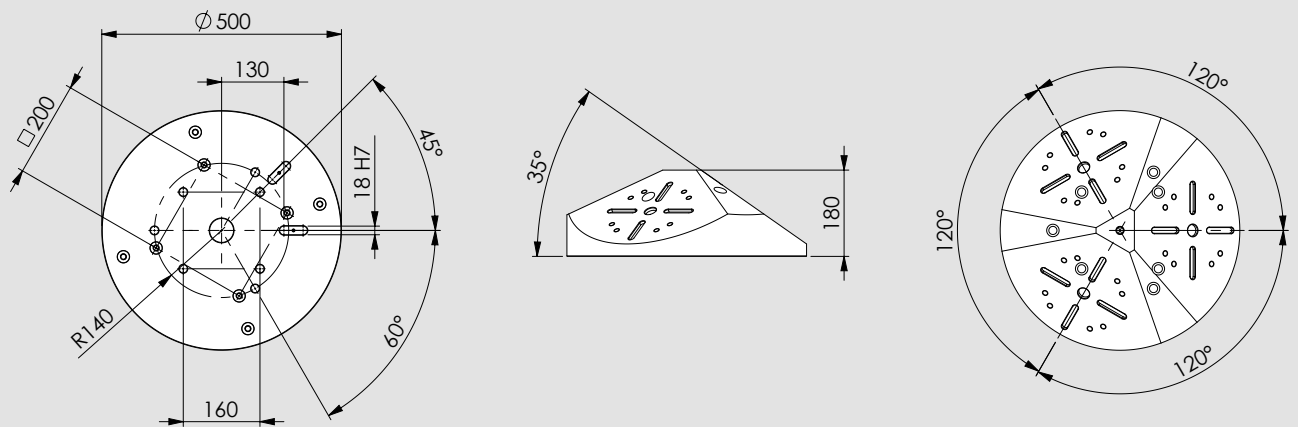

Type	Id. No.	Weight
Alu Pyramid for IMG 88-130	58343210	12 Kg
Alu Pyramid for IMG 125-180 and IMG 125-220	58353210	55 Kg

**Application example**

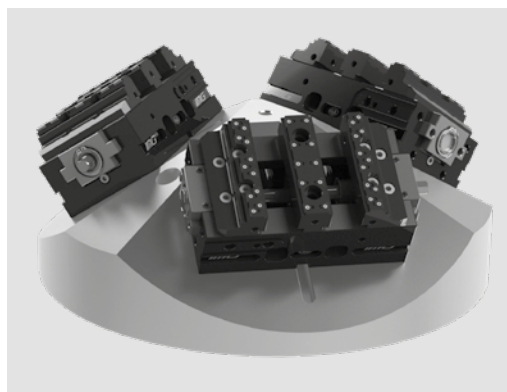

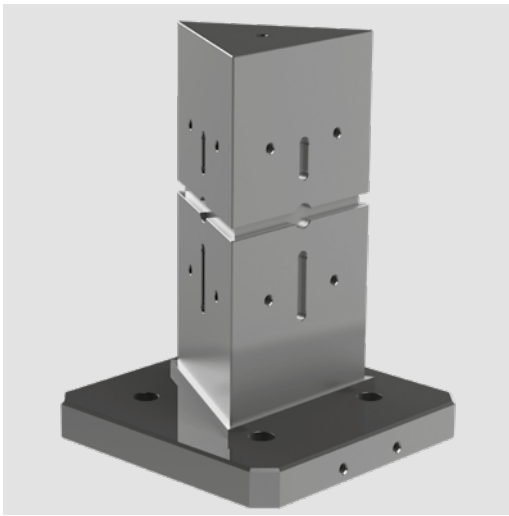

### Applications / Customer Benefits

- Ideal for 5 axis machines
- Ideal for horizontal machines
- Compact design
- Wide clamping range

### Technical features

- Material: steel

### Standard equipment

Steel tombstone

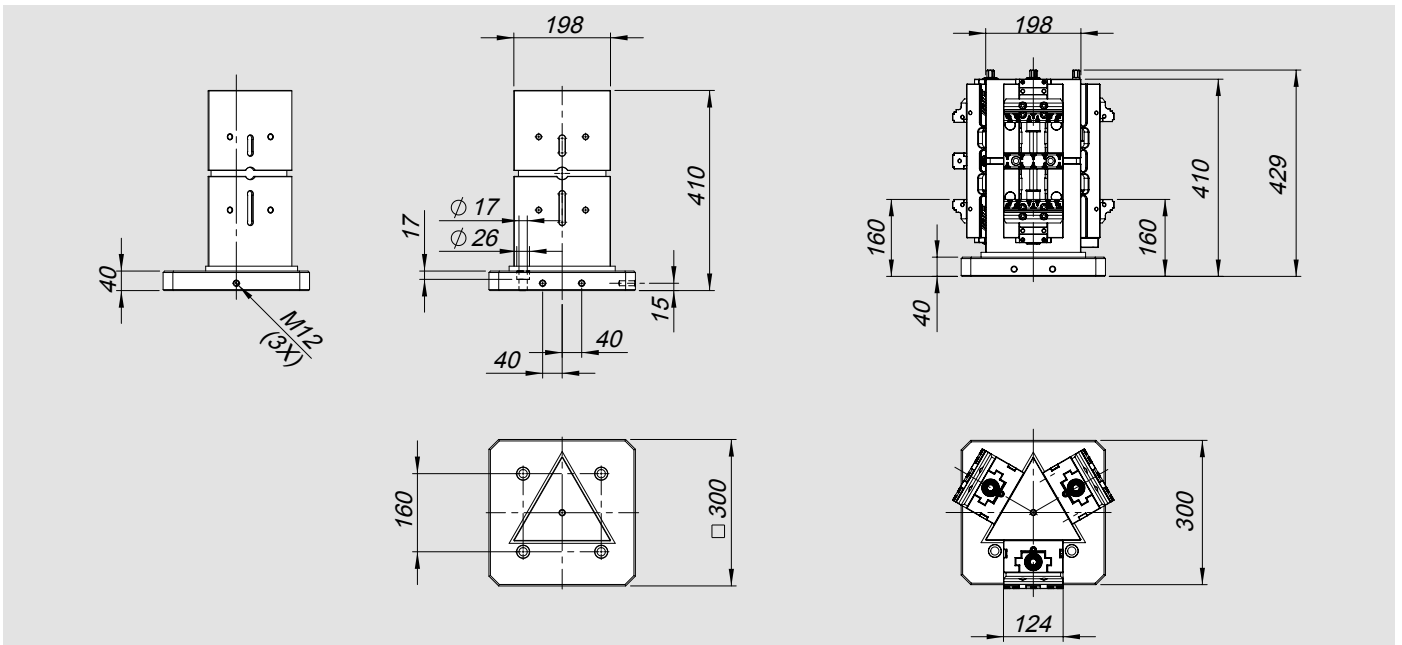

Type	Id. No.	Weight
Triangular tombstone for IMG 125-320	58353010	74 Kg

### Application example

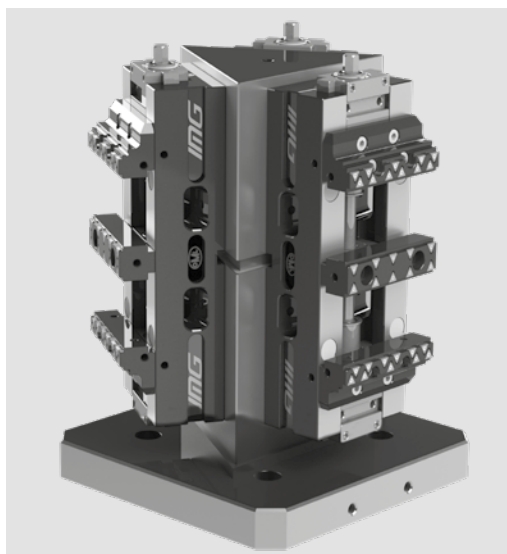



**Applications / Customer Benefits**

- Ideal for horizontal machines
- Compact design
- Wide clamping range

**Technical features**

- Material: steel

**Standard equipment**

Steel tombstone

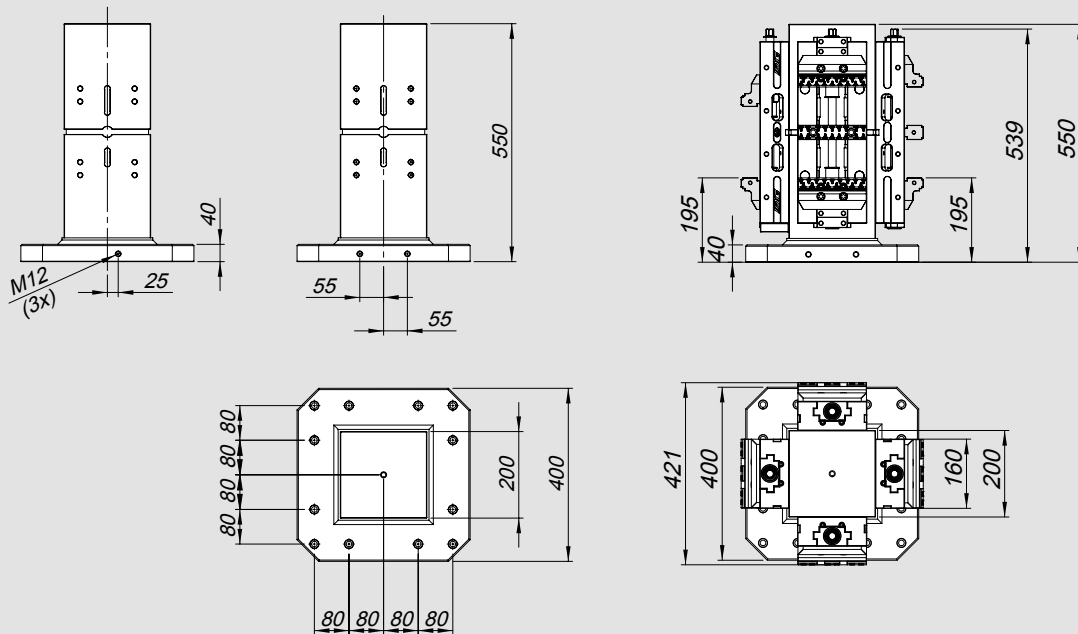

Type	Id. No.	Weight
Tombstone for IMG 160-420	58363120	140 Kg

Application example

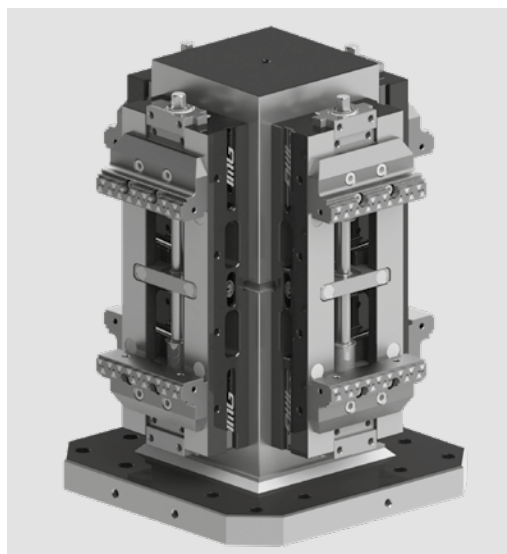

### Clamping pins APS 140



**Typo A**  
centering pin



**Typo B**  
reference pin

#### Application/customer benefits

- Fixation and positioning on the clamping systems APS 140
- Wear-resistant due to an extra hard protective coating
- Large entry radii of the clamping pins for easy and safe loading

#### Technical features

- Centering pin Type A (Standard)
- Sword pin Type B (Positioning pin)

#### Standard equipment

Clamping pin with mounting screw M10x45

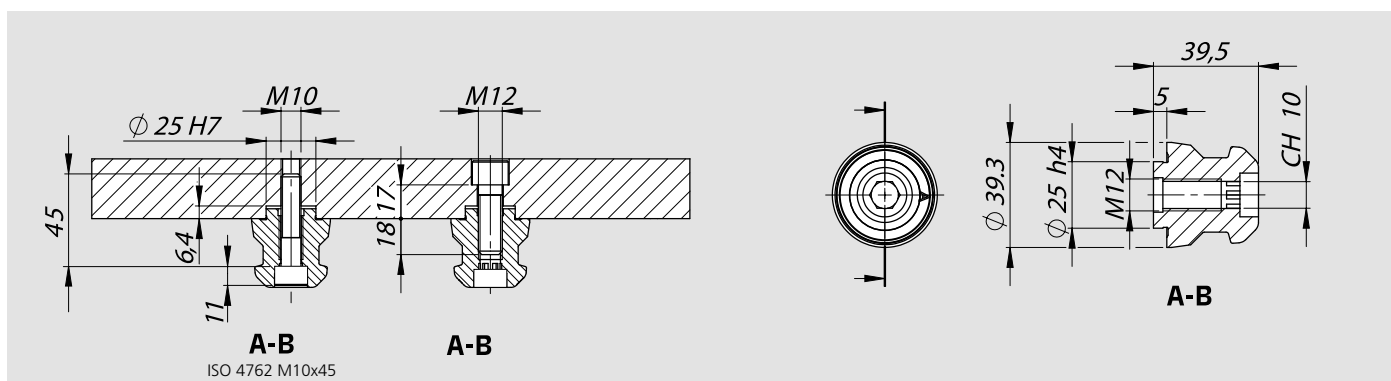

	Thread	Type A	Type B	Weight
Clamping pins APS 140	M12	46162355	46162356	0.3 Kg

### Clamping pins APS 190



#### Application/customer benefits

- Fixation and positioning on the clamping systems APS 190
- Large entry radii of the clamping pins for easy and safe loading

#### Technical features

- Centering pin Type A (Standard)

#### Standard equipment

Clamping pin with mounting screw M8x40 (6 pieces)

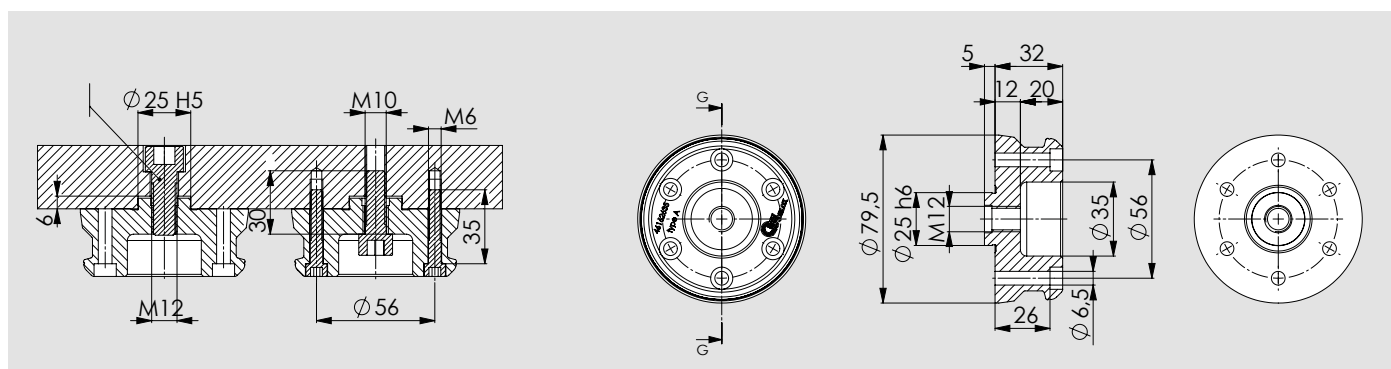

Id. No.	Type	Weight
46 16 26 35	A $\phi 25 = \text{at pin APS-140 M12}$	0,85Kg



Application examples

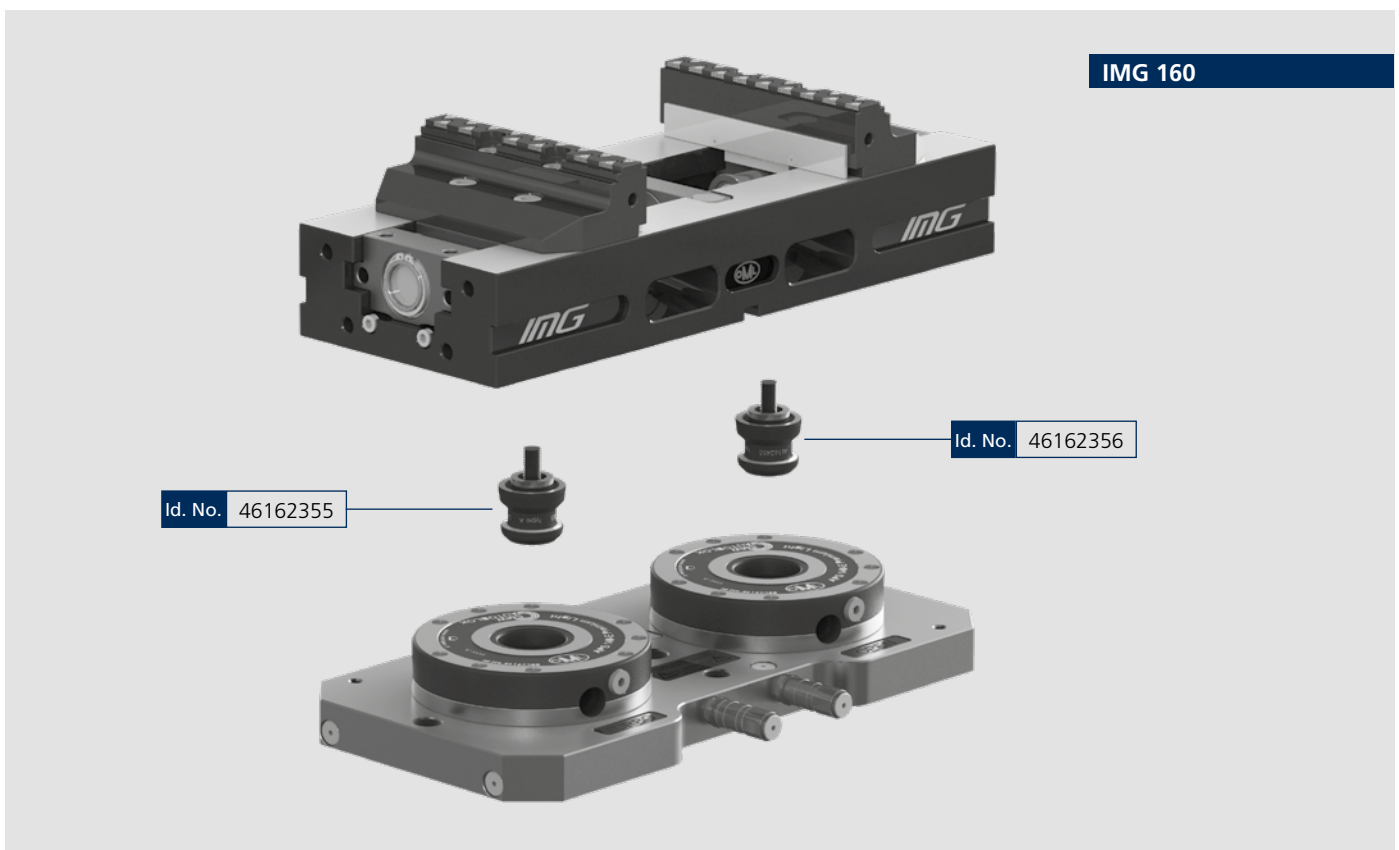
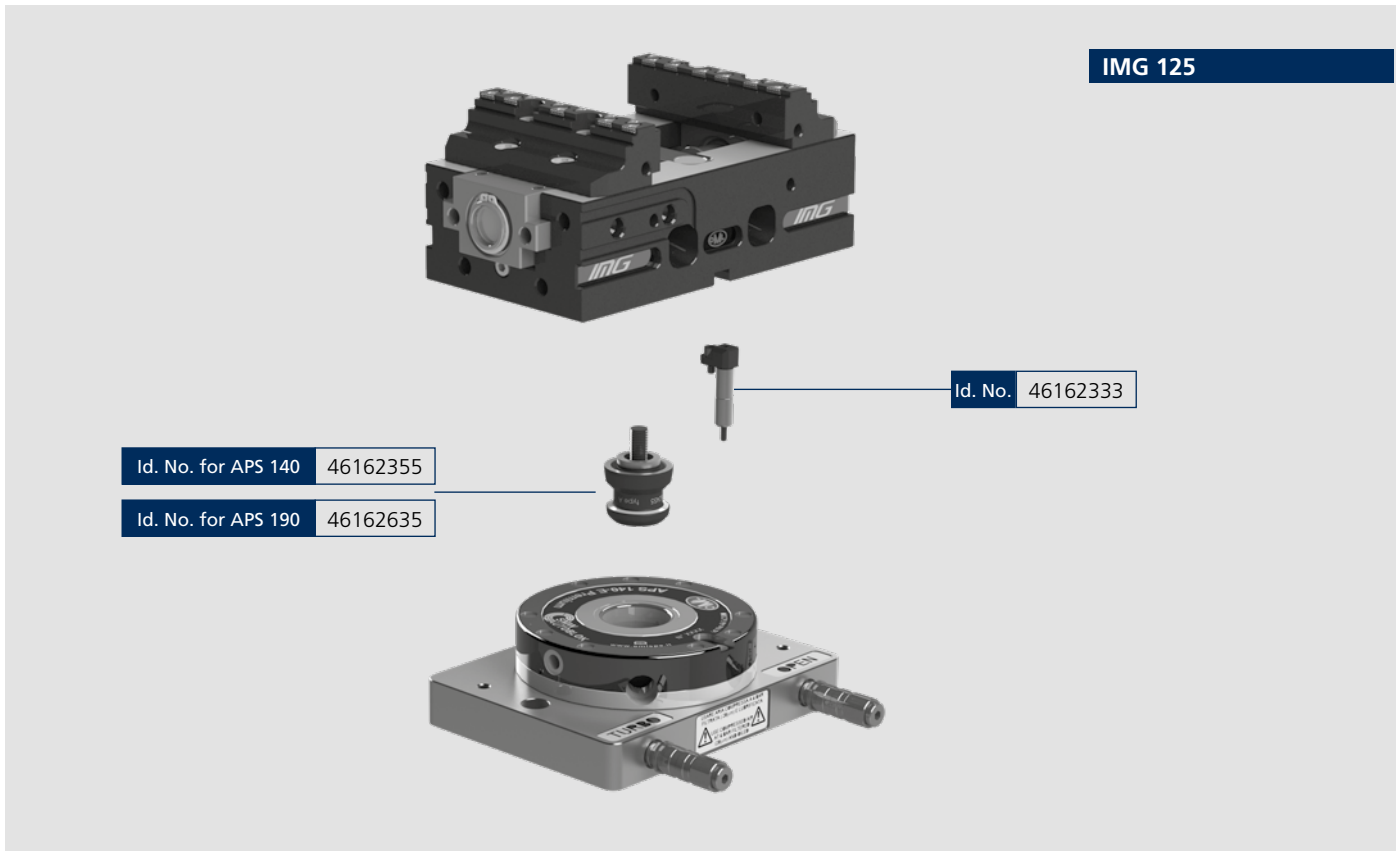



### Quick change modular parallels

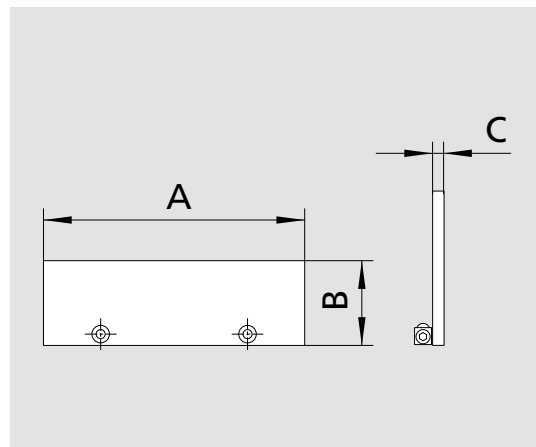
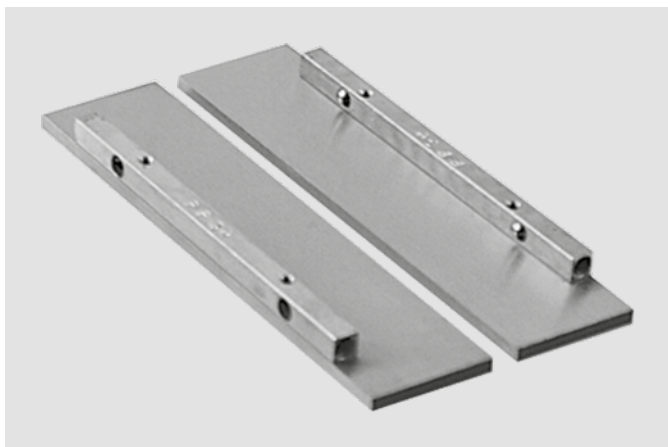

Type	Id. No.	B	A	C
For IMG 88	58343510	10	87	4
For IMG 88	58343515	15	87	4
For IMG 88	58343520	20	87	4
For IMG 88	58343525	25	87	4

Type	Id. No.	B	A	C
For IMG 125	58455115	15	124	4
For IMG 125	58455120	20	124	4
For IMG 125	58455125	25	124	4
For IMG 125	58455130	30	124	4
For IMG 160	58455315	15	159	4
For IMG 160	58455325	25	159	4
For IMG 160	58455335	35	159	4
For IMG 160	58455340	40	159	4

### Application example

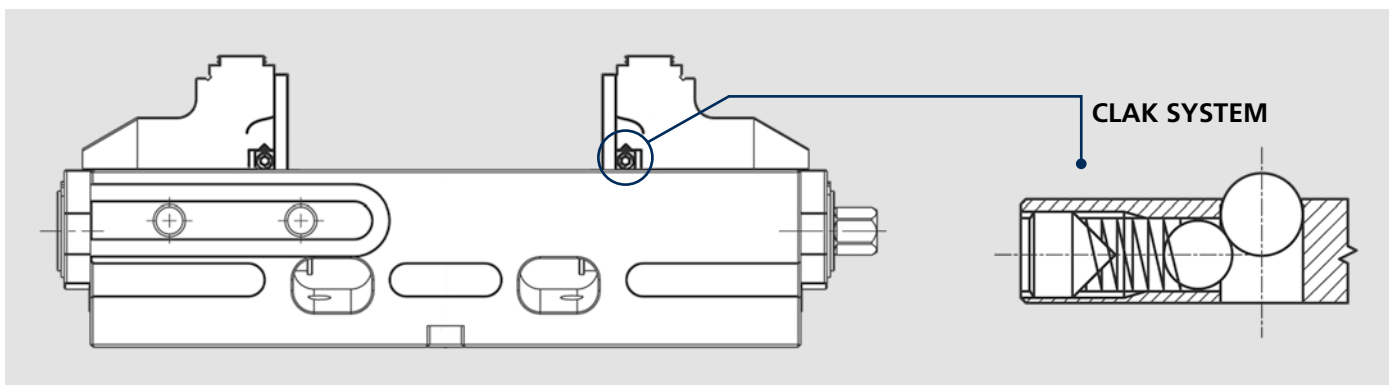

### Torque Wrench



Type	Id. No.
IMG 88	51501026
IMG 125	51501021
IMG 160	51501022

### Workstop

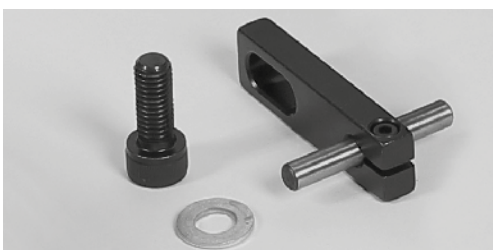

Type	Id. No.
IMG 88	58415030
IMG 125-160	58315020

Key for APS for single use (APS side)



Type	Id. No.
APS 140 / 190	46162333

Pair of positioning keys for T Slot

Only for IMG 125-160



IMG 125 - 160	mm 12 - h6
mm 12 - h6	58351392
mm 14 - h6	58351393
mm 16 - h6	58351394
mm 18 - h6	58351395
mm 20 - h6	58351396
mm 22 - h6	58351397

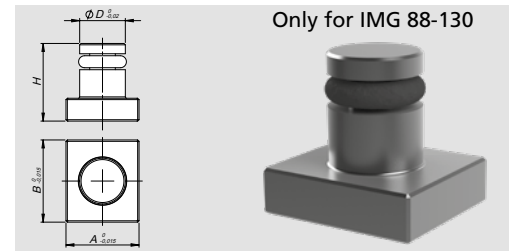

Only for IMG 88-130

IMG 88 - 130	A	B	H	D
58341393	12	14	17	10
58341395	16	18	17	10

Key for single use on APS 140 for IMG 125 (vice body side)

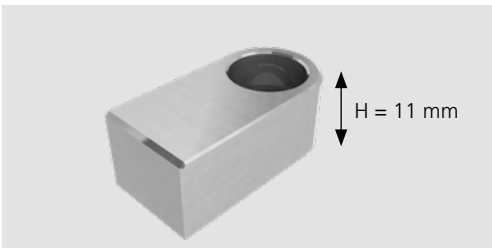

Type	Id. No.
IMG 88	58351312
IMG 125	

Key for single use on APS 160 for IMG 160 (vice body side)

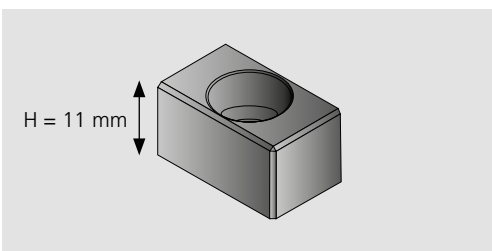

Type	Id. No.
IMG 160	58361312

Pair of Clamps

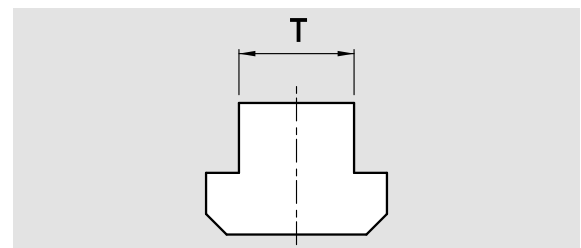
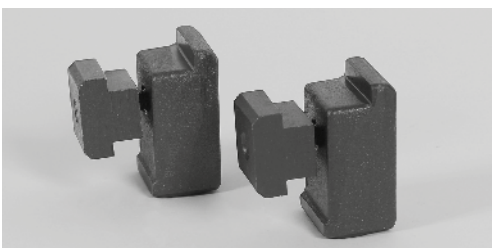

Type	mm 12	mm 14	mm 16	mm 18	mm 20	mm 22
IMG 88	58012792	58012793	58012794	58012795	58012796	58012797
IMG 125 / 160	58022792	58022793	58022794	58022795	58022796	58022797

### SinterGrip

	Id. No.	Description
	58 45 01 19	Set of 10 SinterGrip inserts <b>STD</b> for steel
	58 45 01 29	set of 10 SinterGrip inserts <b>HRC</b> for hardened steel / titanium until 50-54 HRC
	58 45 01 39	Set of 10 SinterGrip inserts for <b>ALU</b>
	58 45 02 19	Kit 10VTX30 for inserts SINTERGRIP
	58 45 05 19	Kit 10 protection inserts in aluminum



Find out more

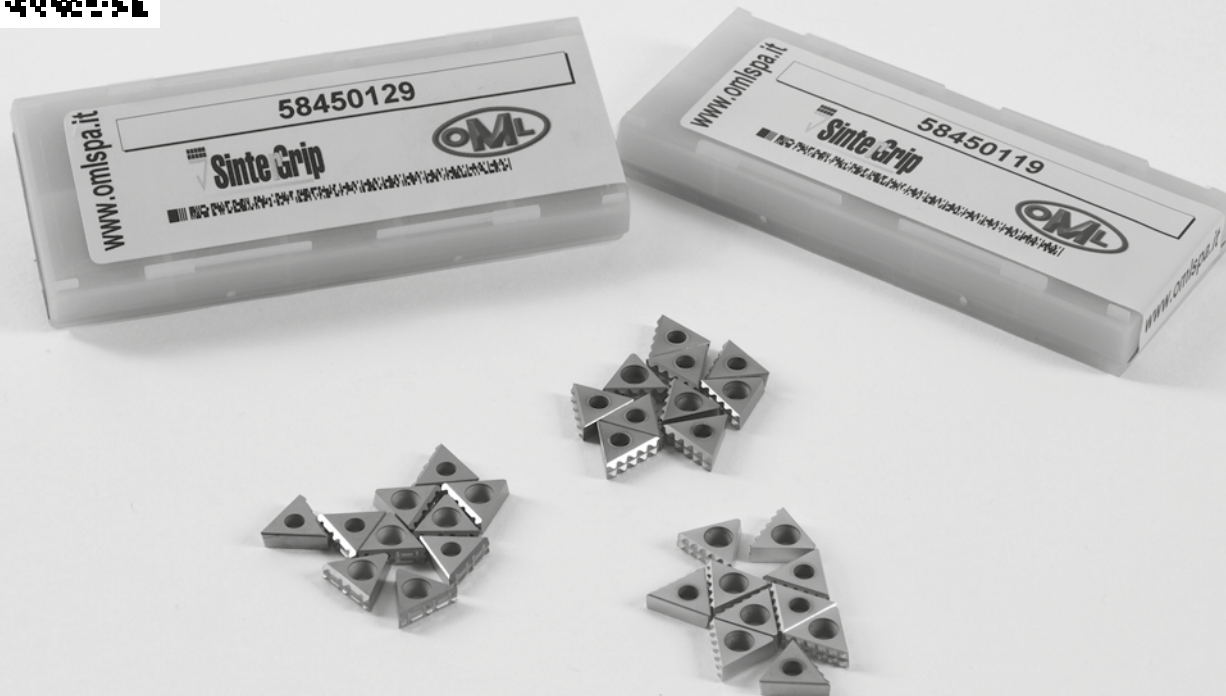

## Pair of SINTERGRIP jaws

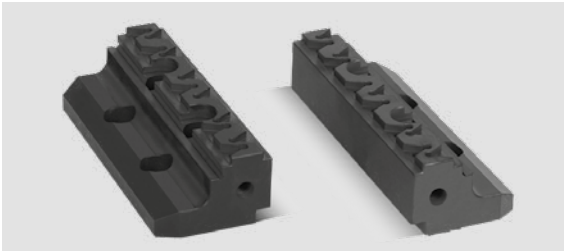

Type	Id. No.
IMG 88	58341219
IMG 125	58351219
IMG 160	58361219

## Pair of BASIC jaws

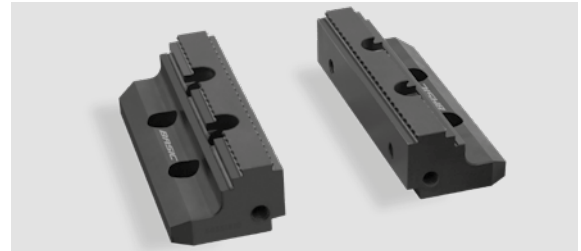

Type	Id. No.
IMG 88	58341259
IMG 125	58351259
IMG 160	58361259

## Wrench

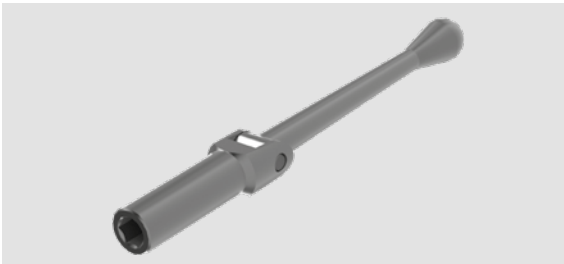

Type	Id. No.
IMG 125	58351910
IMG 160	58361910

## Wrench



Type	Id. No.
IMG 88	58341910

## Spindel group

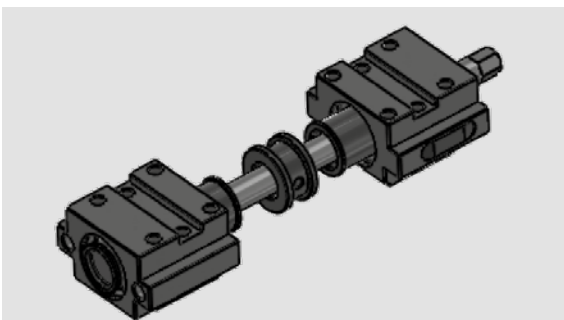

Type	Id. No.
IMG 88-130	58349010
IMG 125-180	58359030
IMG 125-220	58359010
IMG 125-320	58359020
IMG 160-270	58369010
IMG 160-420	58369020

## Magnetic extractor for IMG protection plug



Id. No.	71290755
---------	----------

### Exploded

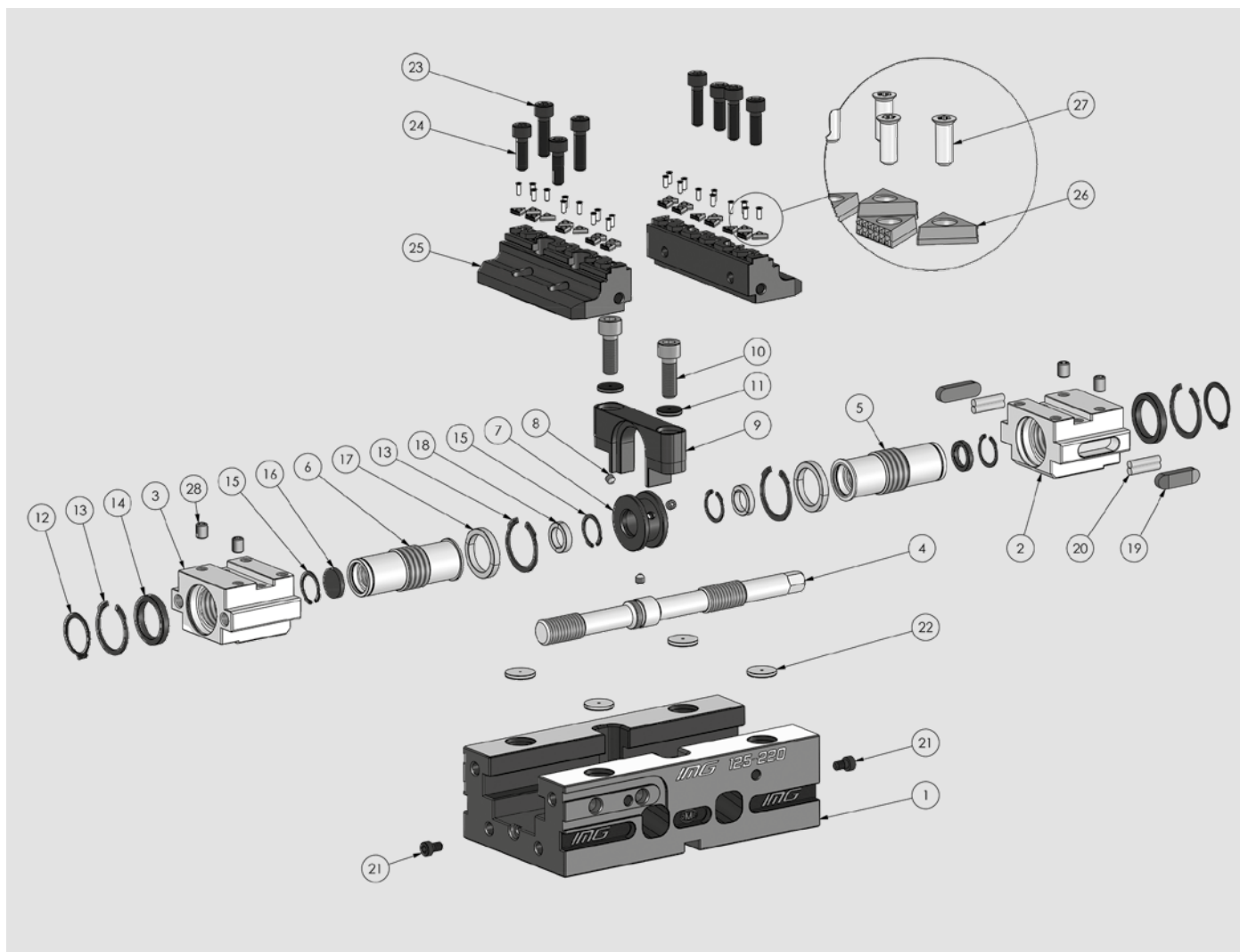

	Description
1	IMG BASE
2	LEFT SLIDE WAY
3	RIGHT SLIDE WAY
4	OPERATING SCREW
5	LEFT BUSHING
6	RIGHT BUSHING
7	SCREW STOP
8	SCREW
9	UPPER SUPPORT
10	SCREW

	Description
11	ALU PLUG FOR M10
12	SEEGER RING
13	SEEGER RING
14	O - RING
15	SEEGER RING
16	PLUG
17	BRONZE RING
18	SNAP RING
19	STOP KEY
20	RUBBER KEY

	Description
21	SCREW
22	ALU PLUG FOR M12
23	SCREW
24	SCREW
25	SINTERGRIP JAW
26	SINTERGRIP INSERTS
27	SCREW FOR SINTERGRIP
28	GRUB SCREW