

## Multiple clamping system

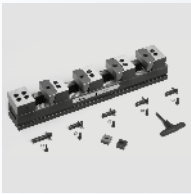

**TETRABLOK**  
4 positions clamping equipment

Page 6.3.2

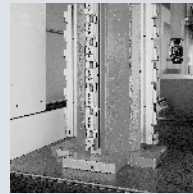

**TETRABLOK**  
Spare parts

Page 6.3.6



**TETRABLOK**  
Accessories

Page 6.3.4

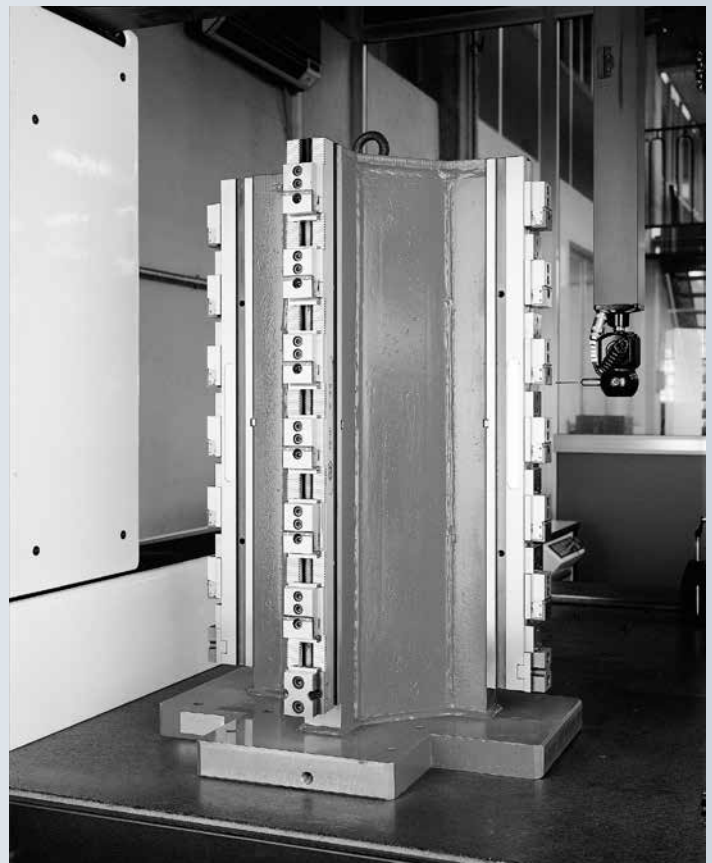

# TETRABLOK

## 4 POSITIONS CLAMPING EQUIPMENT

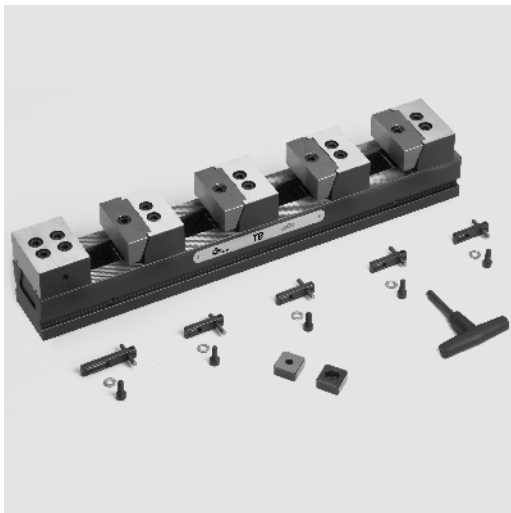

4 positions clamping equipment "TETRABLOK" joins CIVI 2000 with a good price/quality ratio

Complete with: 1 base (length optional), 1 fixed support, 4 sets of movable jaws, 4 workstops, 1 t-wrench.

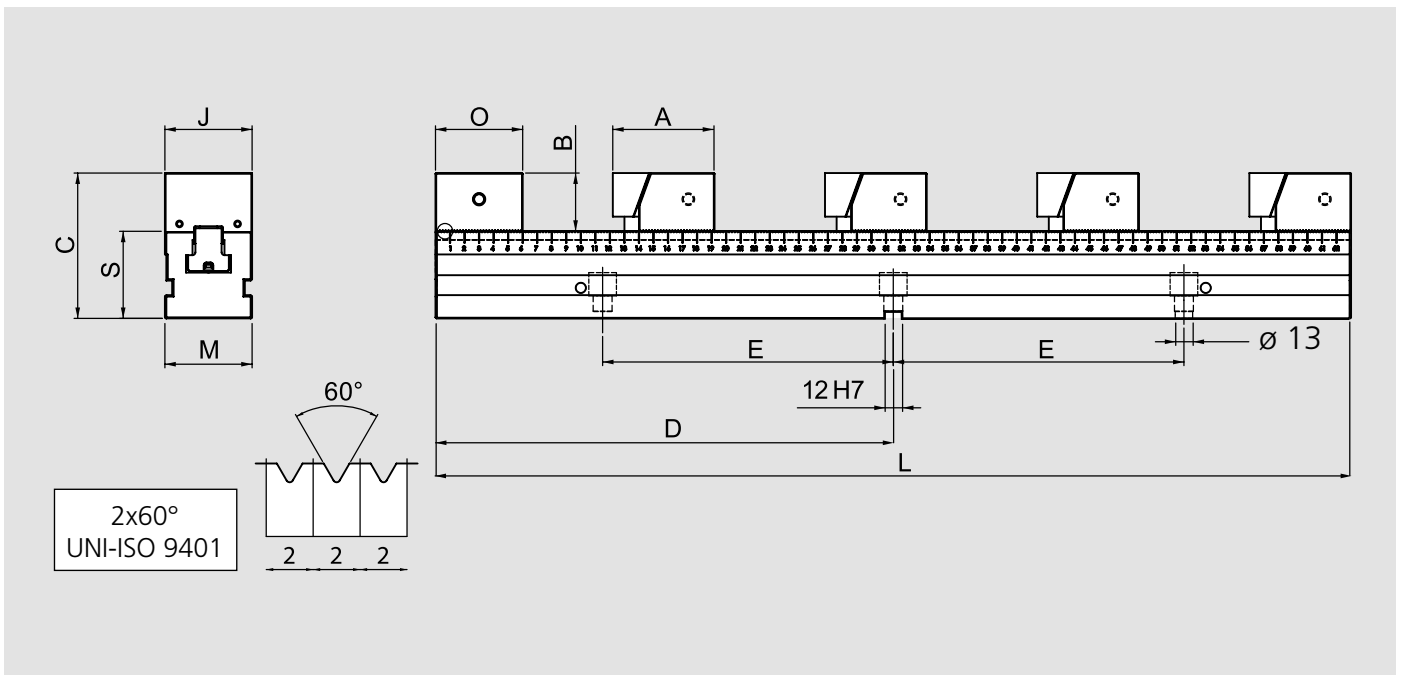

For type	Id. No.	A mm	B mm	C mm	D mm	E mm	J mm	L mm	M mm	O mm	S ±0.01 mm	Weight kg
TB 60-400	77588101	70	40	100	200	100	60	400	60	60	60	16.9
TB 60-500	77588102				250	150		500				18.9
TB 60-630	77588103				315	200		630				22.0
TB 90-400	77588201	80	45	115	200	100	90	400	90	70	70	27.6
TB 90-500	77588202				250	150		500				32.8
TB 90-630	77588203				315	200		630				36.7

Clamping force diagram

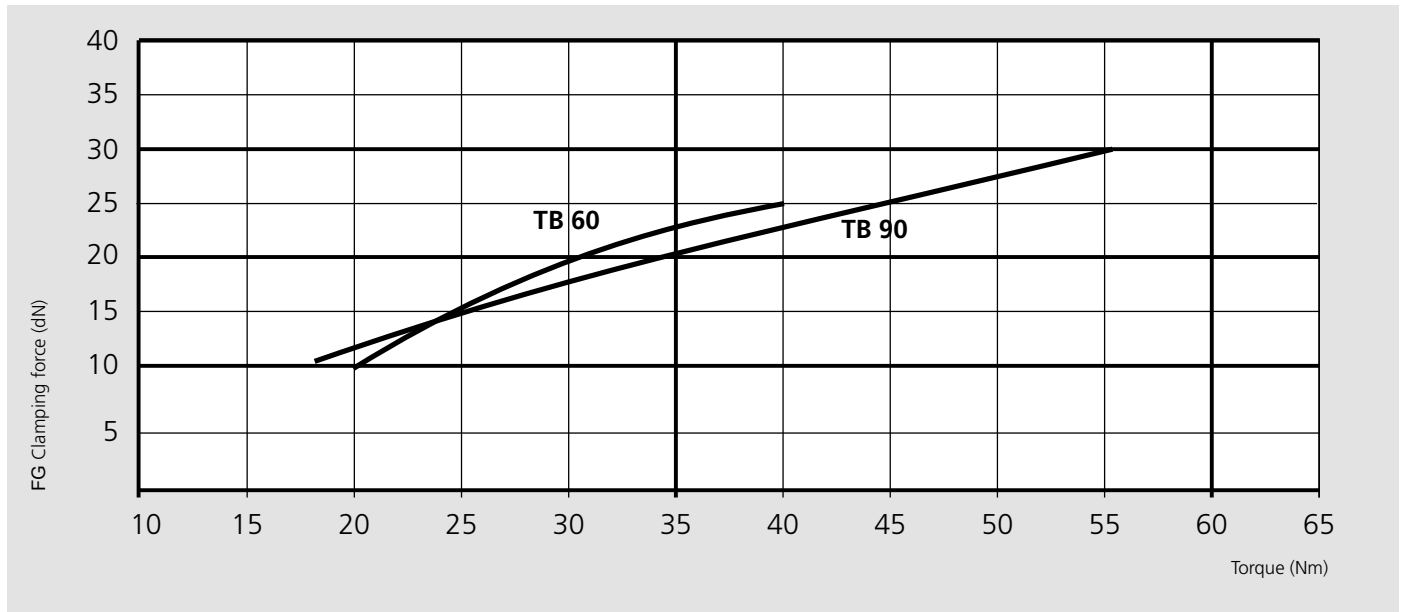

Clamping capacity

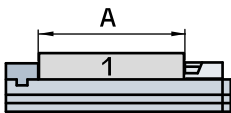
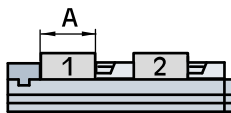
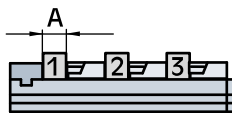
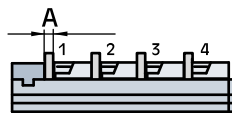
				
TB 60-400	270	100	43	15
TB 60-500	370	150	76	40
TB 60-630	500	215	120	73
TB 90-400	249	84	29	-
TB 90-500	349	134	62	26
TB 90-630	479	199	106	59

#### Set of n. 4 pair of parallels for TETRABLOK

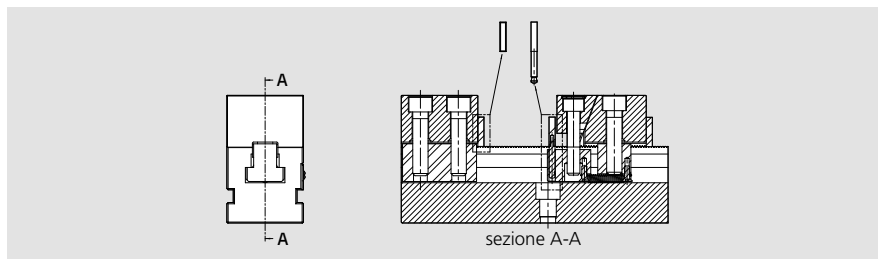

For type	Id. No.	Weight kg
TB 60	58819204	0.4
TB 90	58829204	0.7

#### Pair of parallels for TETRABLOK

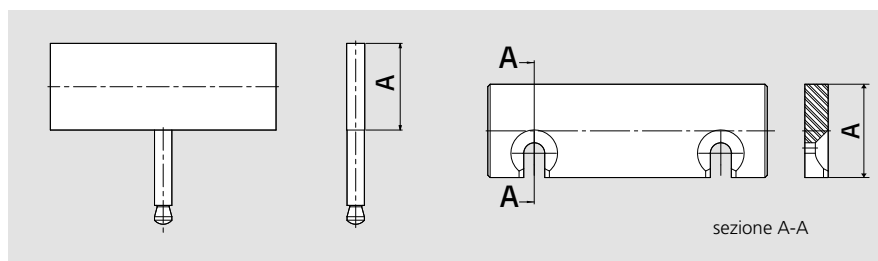
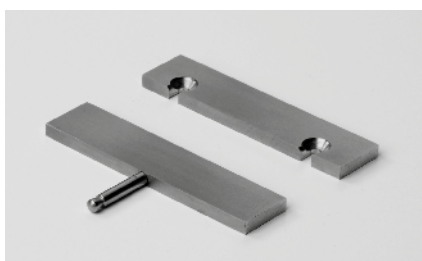

For type	Id. No.	A mm
TB 60	58813518	18
TB 60	58813523	23
TB 60	58813528	28
TB 60	58813537	37
TB 90	58823518	18
TB 90	58823523	23
TB 90	58823533	33
TB 90	58823542	42

#### Pair of standard positioning keys

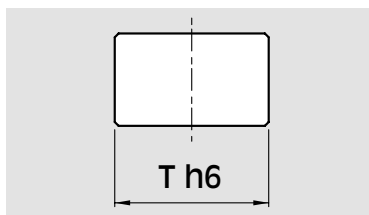
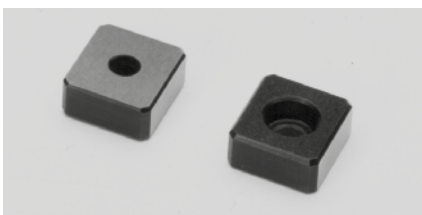

For type	Id. No.	T h6 mm
TB 60/90	58011592	12

#### Pair of special positioning keys

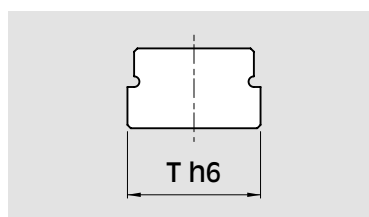
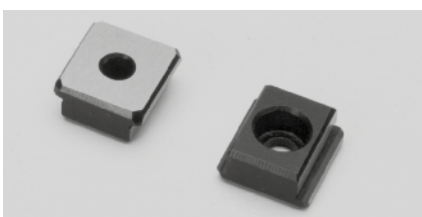

For type	Id. No.						
	Th6	12 mm - h6	14 mm - h6	16 mm - h6	18 mm - h6	20 mm - h6	22 mm - h6
TB 60/90	-	58011593	58011594	58011595	58011596	58011597	

Complete fixed support

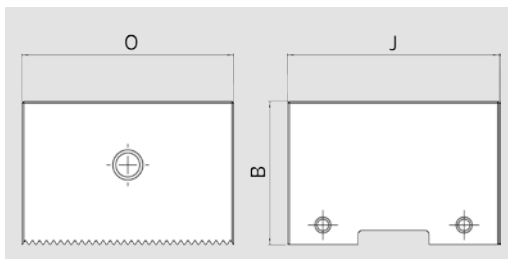

For type	Id. No.	B mm	J mm	O mm	Weight kg
TB 60	58817220	40	60	70	1.3
TB 90	58827220	45	90	80	2.8

Movable support with jaw

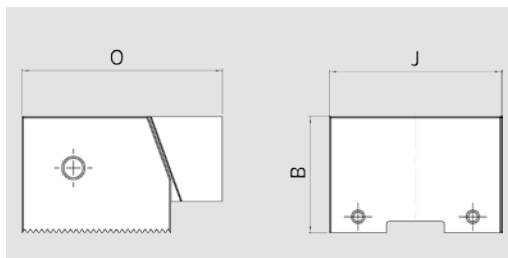

For type	Id. No.	B mm	J mm	O mm	Weight kg
TB 60	77588123	40	60	70	1.4
TB 90	77588223	45	90	80	3

Smooth jaw



For type	Id. No.
TB 60	58810409
TB 90	58820409

Work stop

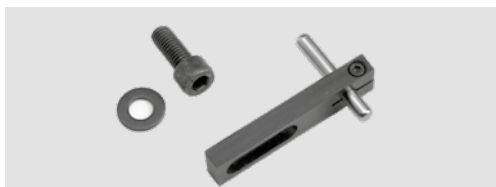

For type	Id. No.
TB 60	58315010 fixed
TB 90	58325010 fixed
TB 60/90	58315020 movable

Pair of clamps complete with screw and T-nut

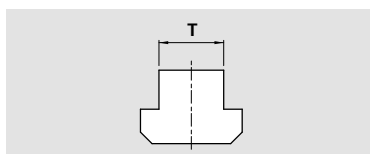

For type	Id. No.					
	12 mm	14 mm	16 mm	18 mm	20 mm	22 mm
TB 60	58012792	58012793	58012794	58012795	58012796	58012797
TB 90	58022792	58022793	58022794	58022795	58022796	58022797

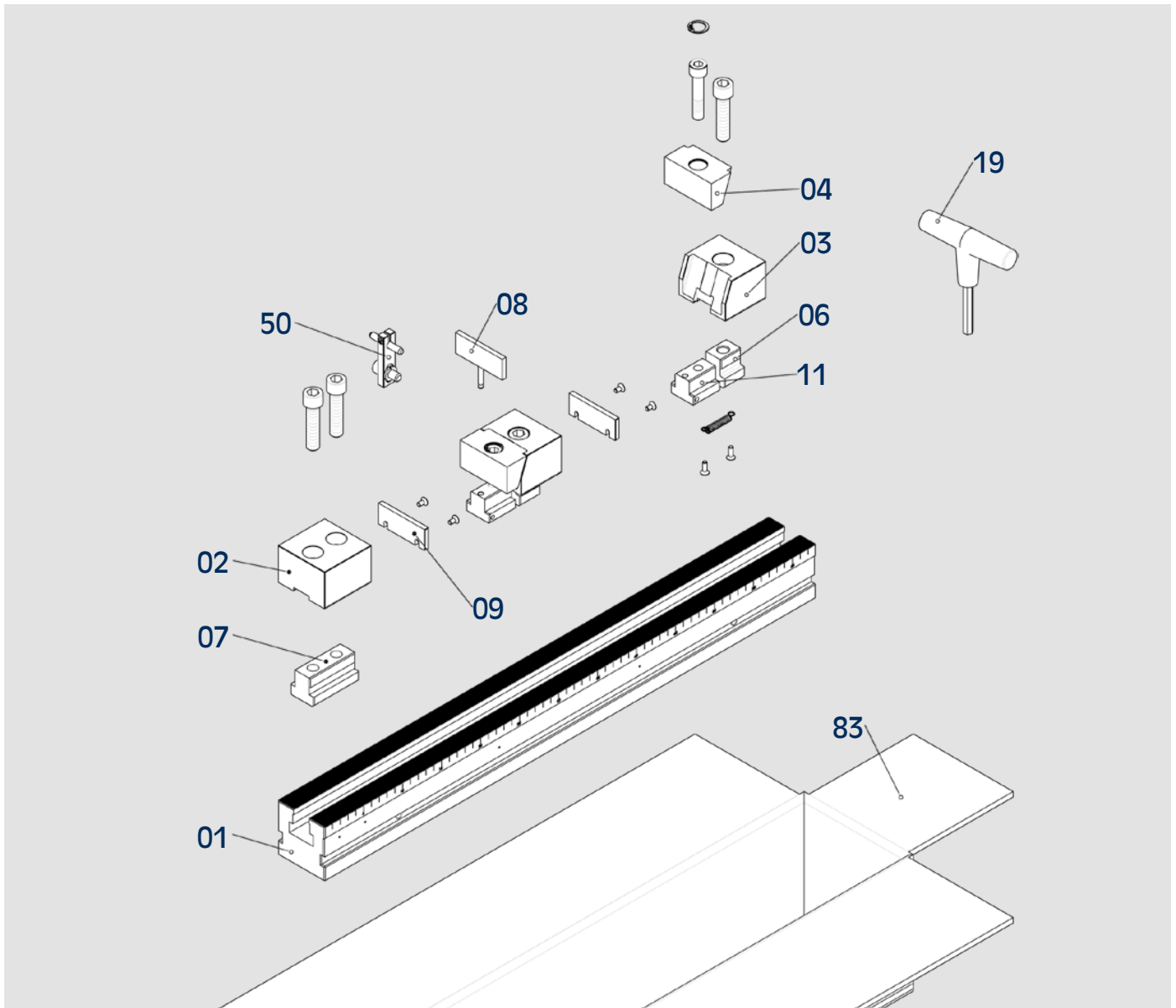

### Description

01	Base	06	Nuts	11	Nuts
02	Fixed support	07	Nuts	19	T-wrench
03	Movable support	08	Parallel	50	Work stop
04	Jaw	09	Parallel	83	Cardboard box