

VP-N

9.2



NC Clamping Vice



VP-N

NC Clamping Vice

Page 9.2.4



VP-N

SINTERGRIP

Page 9.2.9



VP-N

Accessories

Page 9.2.6



Quick change system of the spindle unit
 Disassembling of the spindle unit without tools
 Easy and quick cleaning of the vice

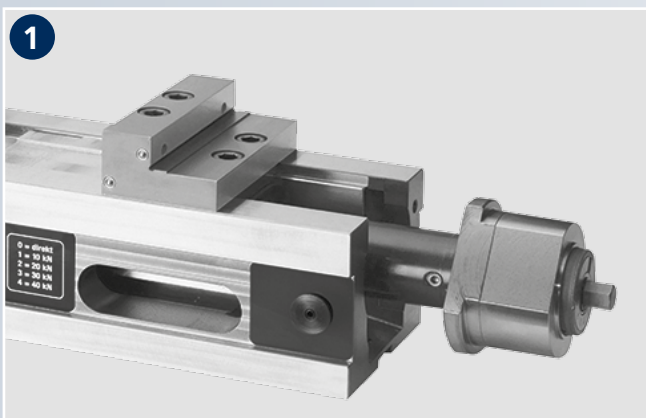

Parallels with quick change system
 Mounting of parallels without tools
 No penetration of chips below parallels



NC Clamping Vice

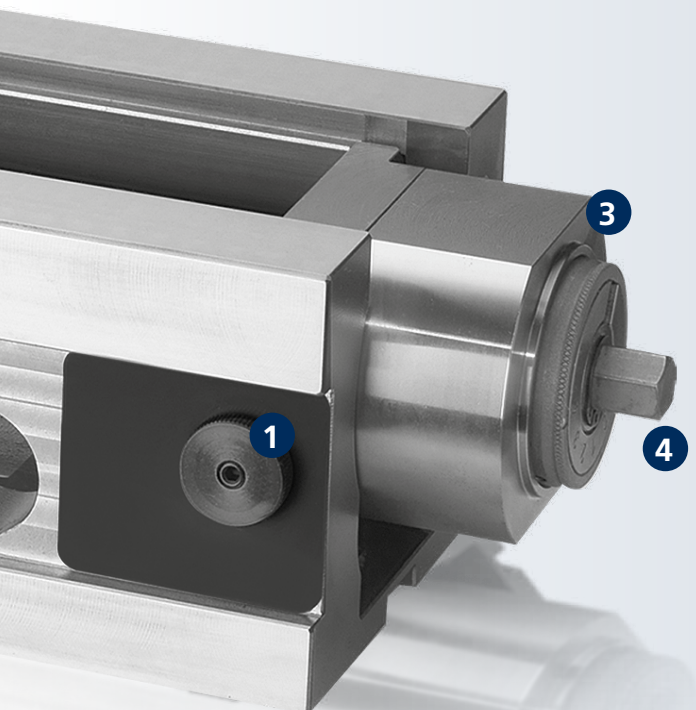

Protected spindle with mechanical power intensifier
Exact pre-select of the clamping force (up to 11 steps)
Constant clamping force for maximum process reliability

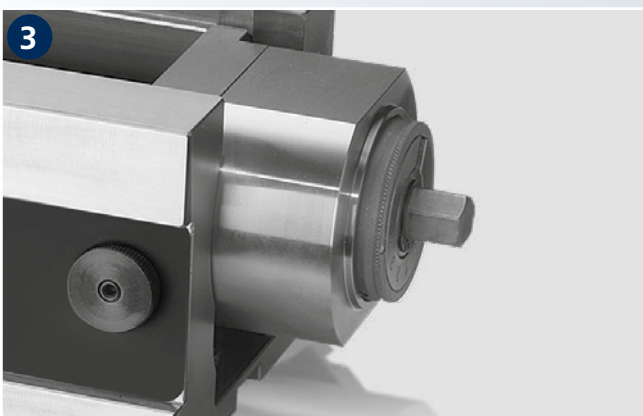

Interface for zero point clamping systems APS | WPS
as a standard for highest efficiency while set-up

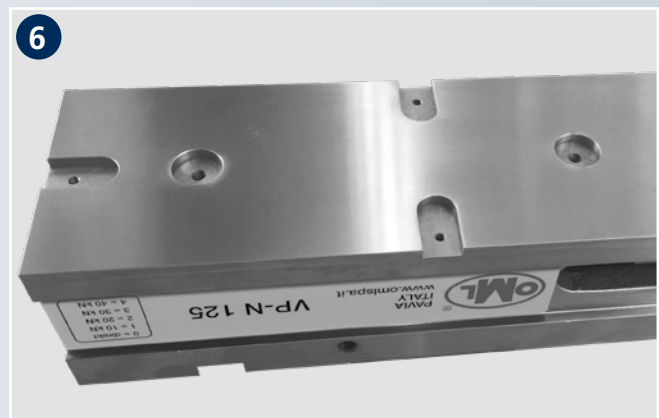

SinterGrip
Jaws for SinterGrip clamping inserts as an accessory for
OP 10 operations available



Angle drive (accessory)
Easy use on the machine table
Best accessibility for the setting of the clamping force



- With precision power transmitter
- Clamping against fixed jaw

Technical features

- High clamping forces (up to 60 kN)
- 3 different sizes
- Precision guideway hardened and ground
- Interface for zero point clamping systems
- APS / WPS as a standard

Standard equipment

- VP-N clamping vice together with hand crank
- 4 pieces clamps for fixing

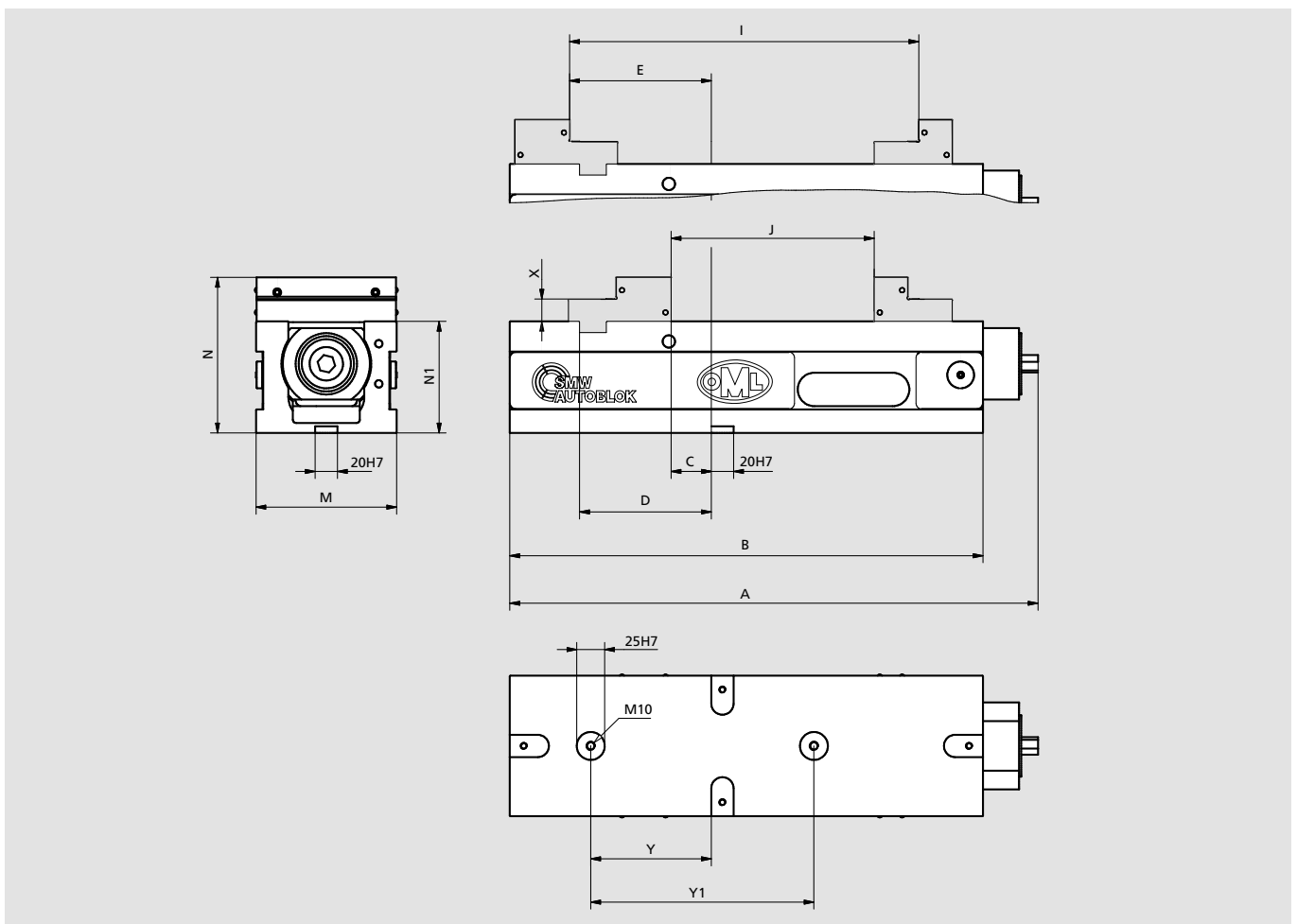

Id. no	Type	A	B	C	D	E	J	I	M	N	N1	X	Y	Y1	Clamping force	Weight
46 27 34	VP-N 90	340	305	15	73	75	0-126	91-217	90	114,0	80	16	58	200	kN	Kg
46 27 35	VP-N 125	483	424	36	118	127	0-182	131-313	126	139,5	100	20	108	200	40	35
46 27 36	VP-N 160	616	560	70	164	178	17-263	187-433	164	164,8	115	25	114	300	60	60

- With precision power transmitter
- Clamping against fixed jaw

Clamping force diagrams

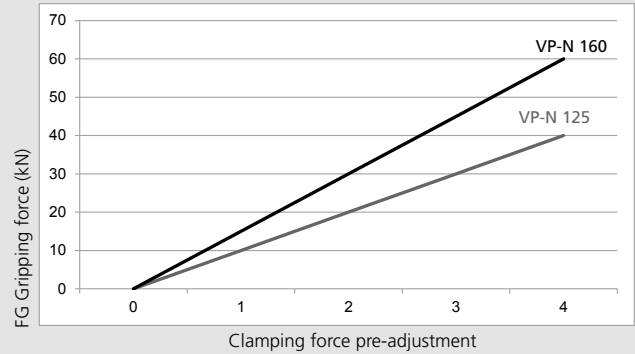
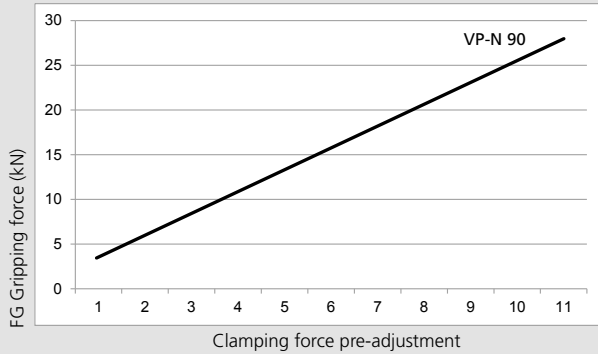

Manufacturing tolerances for all types of vices

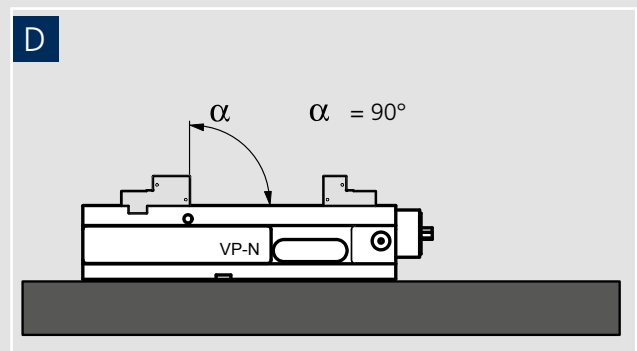
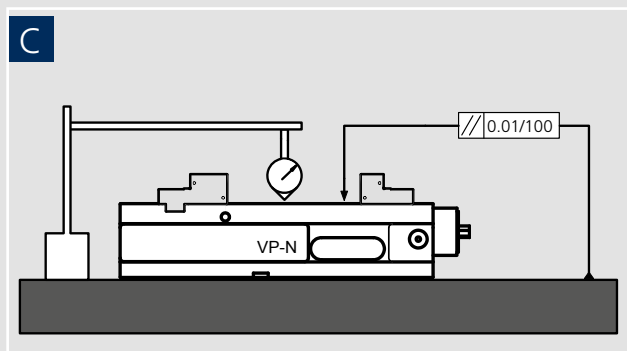
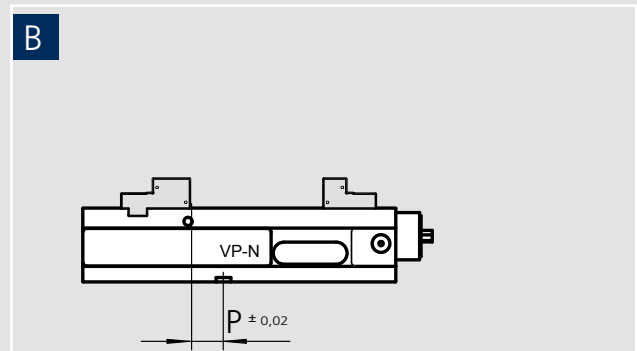
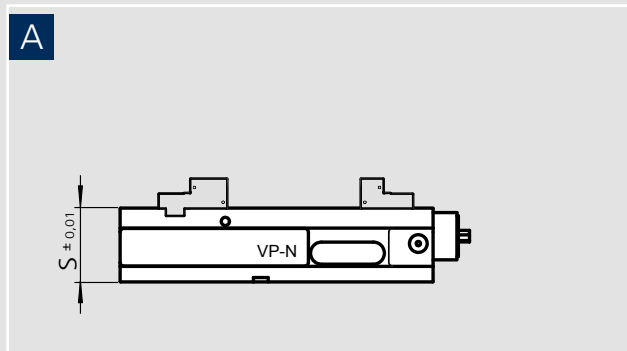

Flat clamping jaw hardened and grinded

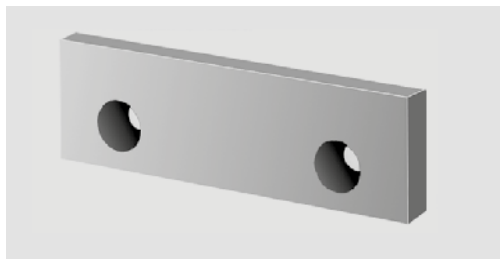

Id. No.	Type	Height	Depth
		mm	mm
46 27 38	VP-N 90	34.0	10
46 27 39	VP-N 125	39.2	12
46 27 40	VP-N 160	49.2	16

Consisting of: 1 piece clamping jaw

Flat clamping jaw soft (material 1.2842)

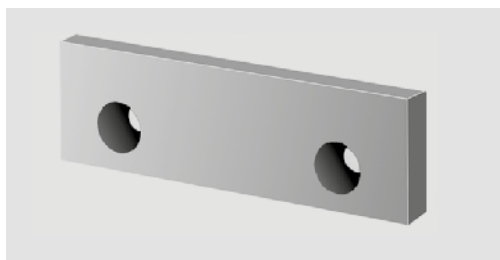

Id. No.	Type	Height	Depth
		mm	mm
46 27 41	VP-N 90	34.0	10
46 27 42	VP-N 125	39.2	12
46 27 43	VP-N 160	49.2	16

Consisting of: 1 piece clamping jaw

Clamping jaw with groove

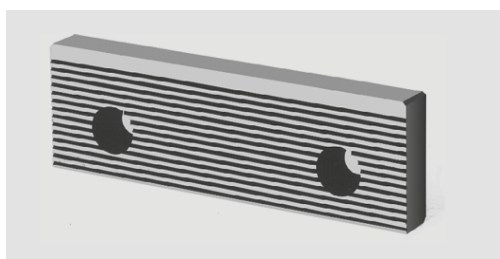

Id. No.	Type	Height	Depth
		mm	mm
46 27 44	VP-N 90	34.0	10
46 27 45	VP-N 125	39.2	12
46 27 46	VP-N 160	49.2	16

Consisting of: 1 piece clamping jaw

Parallel with quick change system



Id. No.	Type	Height	Depth
		mm	mm
46 27 47	VP-N 90	14	3
46 27 48	VP-N 90	30	3
46 27 49	VP-N 125	39	3
46 27 50	VP-N 125	35	3
46 27 51	VP-N 125	15	3
46 27 52	VP-N 160	14	3
46 27 53	VP-N 160	30	3
46 27 54	VP-N 160	44	3

Consisting of: 1 piece level bar

SinterGrip clamping jaw

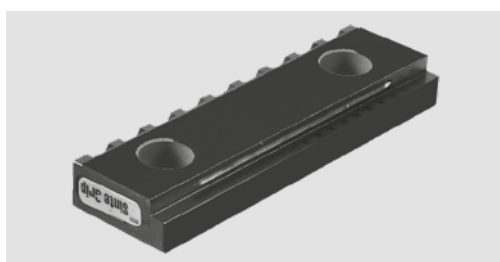

Id. No.	Type	Nr. Sintergrip per jaw	Height	Depth
			mm	mm
46 27 55	VP-N 125	9	39.5	12
46 27 56	VP-N 160	11	49.8	12

Consisting of: 1 piece SinterGrip clamping jaw (without clamping inserts)

Smooth clamping jaw with step

Id. No.	Type	Step	Height	Depth
		mm	mm	mm
46 27 57	VP-N 125	3 x 6	34.0	10
46 27 58	VP-N 125	5 x 10	39.2	12
46 27 59	VP-N 160	5 x 8	49.2	16

Consisting of: 1 piece clamping jaw

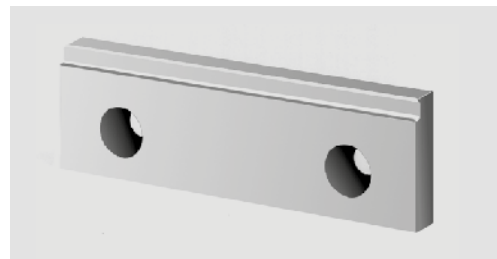

Step jaw for raw parts VP-N 125

Id. No.	Type	Model	Height	Step
		mm	mm	mm
46 27 60	VP-N 125	High step	39.5	1.4 x 4.5
46 27 61	VP-N 125	Low step	19.5	2.0 x 4.5

Consisting of: 1 piece step jaw

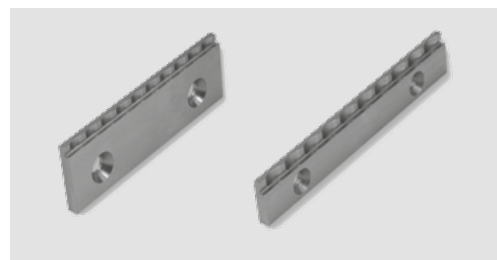

Serrated Clamping jaw with grippers

Id. No.	Type	Height	Depth	Thread	Id. No. Grippers
		mm	mm	mm	
46 27 62	VP-N 90	34	12	M10	46 27 62
46 27 63	VP-N 125	40	12	M10	46 27 63
46 27 64	VP-N 160	50	16	M12	46 27 64

Consisting of: 1 piece clamping jaw

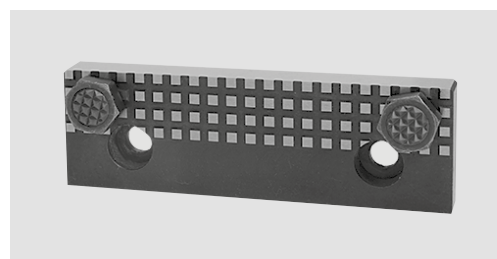

Prismatic jaw horizontal and vertical prisma 90° hardened and grinded

Id. No.	Type	Height	Depth	Clamping min/max mm	
		mm	mm	1 ganascia	2 ganascie
46 27 65	VP-N 90	36.0	17	ø 12-14	ø 18-42
46 27 66	VP-N 125	39.2	28	ø 15-42	ø 24-42
46 27 67	VP-N 160	49.2	32	ø 18-50	ø 28-50

Consisting of: 1 piece clamping jaw

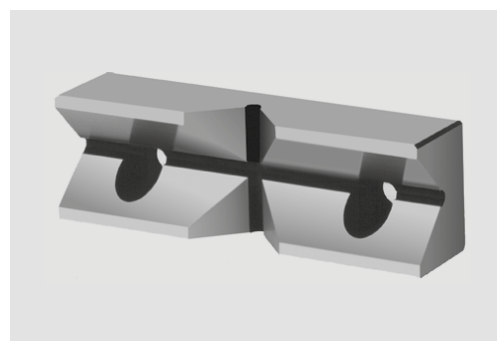

Pull-down jaw with interchangeable insert

Id. No.	Type	Height	Depth
		mm	mm
46 27 68	VP-N 90	34.0	24
46 27 69	VP-N 125	39.2	25
46 27 70	VP-N 160	49.2	28

Consisting of: 1 piece clamping jaw

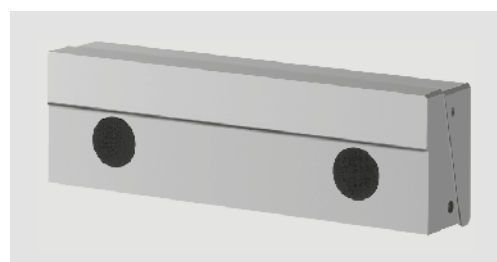

Pull-down jaw for raw parts with spring blade

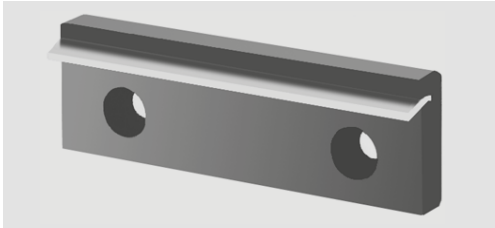

Code	Type	Height mm	Depth mm
46 27 71	VP-N 90	34	18
46 27 72	VP-N 125	40	21
46 27 73	VP-N 160	50	24

Consisting of: 1 piece clamping jaw

Fixed jaw with grippers, Floating jaw with gripper

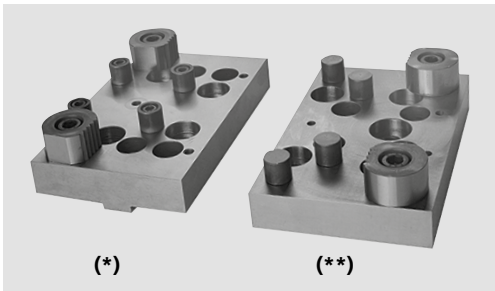

Code	Type	Height mm	Width mm	Lenght mm
46 27 74	VP-N 90 (*)	25	145	90
46 27 75	VP-N 125 (*)	25	170	105
46 27 76	VP-N 160 (*)	25	200	115
46 27 86	VP-N 90 (**)	25	145	90
46 27 87	VP-N 125 (**)	25	170	105
46 27 88	VP-N 160 (**)	25	200	115

Consisting of: 1 piece clamping jaw (*) fixed jaw - (**) movable jaw

Floating jaw

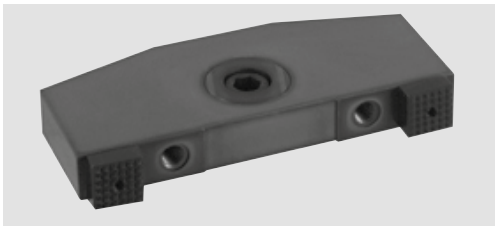

Code	Type	Width mm	Lenght mm	Height mm
46 27 77	VP-N 90	50	141	20
46 27 78	VP-N 125	65	156	20
46 27 79	VP-N 160	76	196	23

Consisting of: 1 piece clamping jaw

Angle drive for VP-N NC Clamping vices

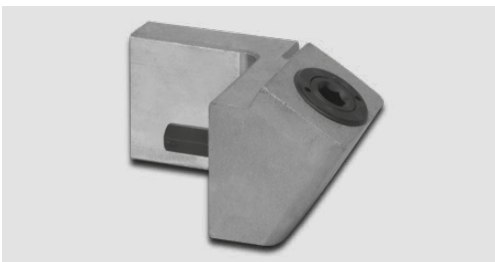

Code	Type	Lenght mm	SW
46 27 80	VP-N 90	12	SW 12
46 27 81	VP-N 125	33	SW 14
46 27 82	VP-N 160	49	SW 14

Consisting of: 1 piece angle jaw

Hand crank standard versione for VP-N NC Clamping vices



Code	Type	Lenght mm	SW
46 27 83	VP-N 90	160	SW 12
46 27 84	VP-N 125	160	SW 14
46 27 85	VP-N 160	160	SW 14

Consisting of: 1 piece hand crank

Positioning Key with screw

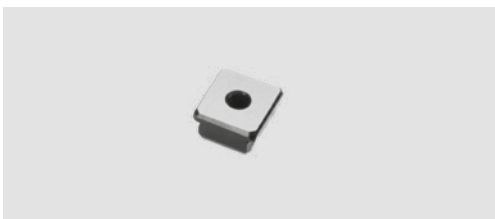

Code	Type mm
46 51 18	20 x 12
46 51 19	20 x 14
46 51 20	20 x 16
46 51 21	20 x 18
46 51 22	20 x 20
46 51 23	20 x 22

Our new product **SinterGrip** is born to satisfy the current need to clamp a workpiece for very few millimeters (with SinterGrip 3,5 mm clamping surface), and this for the following reasons:

- 1) In order to machine the workpiece completely in a single operation (especially for 5 axis machines);
- 2) In order to save money for the raw materials, especially when they have a big impact on the price (aluminum, titanium, etc.)

Indirectly to these reasons, and in order to improve the performance of the machine tool and the tools

**higher cutting speed + higher feed rate =
bigger volume of metal removed =
less time to machine the workpiece**

the market requires safe clamping, which could at the same time possibly avoid the deformations of the piece itself.

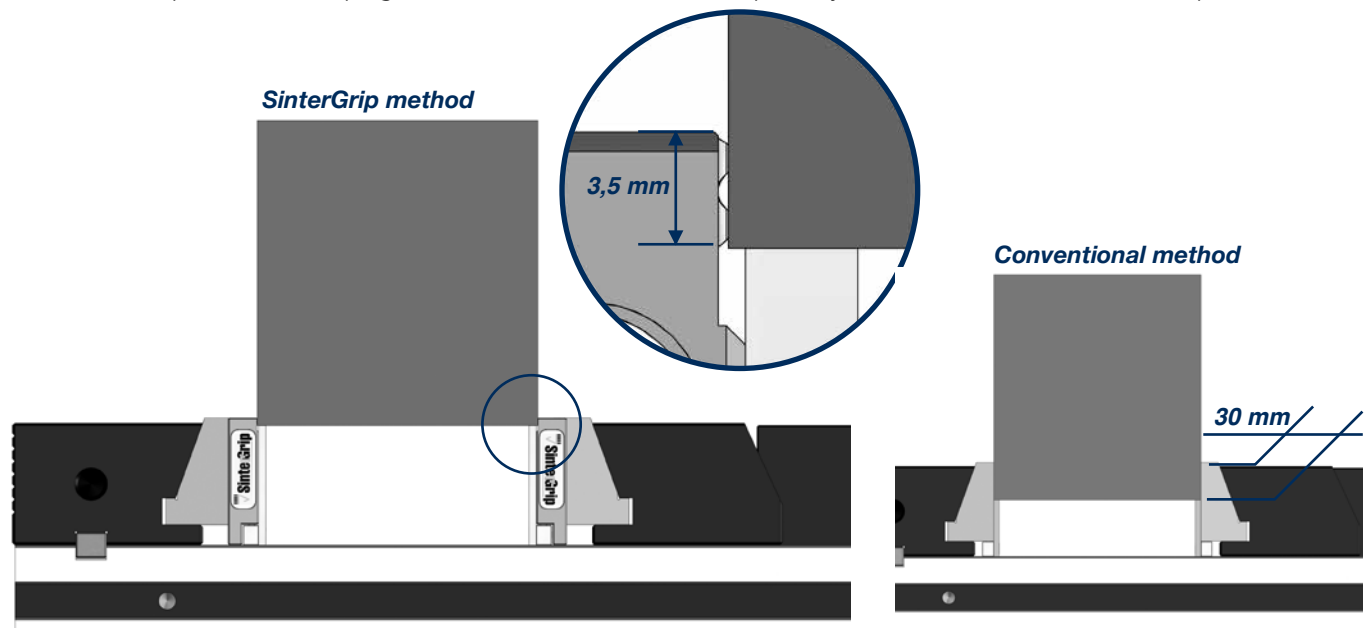

Only 3,5 mm clamping surface, no need of pre-machining the workpiece, clamping stability, higher cutting rate: SinterGrip brings only advantages compared to the traditional systems.

On the contrary, traditional systems need, for the clamping of the workpiece, a bigger clamping surface, with the result of waste of raw materials and greater possibility of deformation of the workpiece.

Working example: jaws mounted on a TC clamp



Working example: inserts SinterGrip mounted.



SinterGrip

	Id. No.	Description
	58 45 01 19	Set of 10 SinterGrip inserts STD for steel
	58 45 01 29	set of 10 SinterGrip inserts HRC for hardened steel / titanium until 50-54 HRC
	58 45 01 39	Set of 10 SinterGrip inserts for ALU
	58 45 02 19	Kit 10VTX30 for inserts SINTERGRIP
	58 45 05 19	Kit 10 protection inserts in aluminum



Find out more

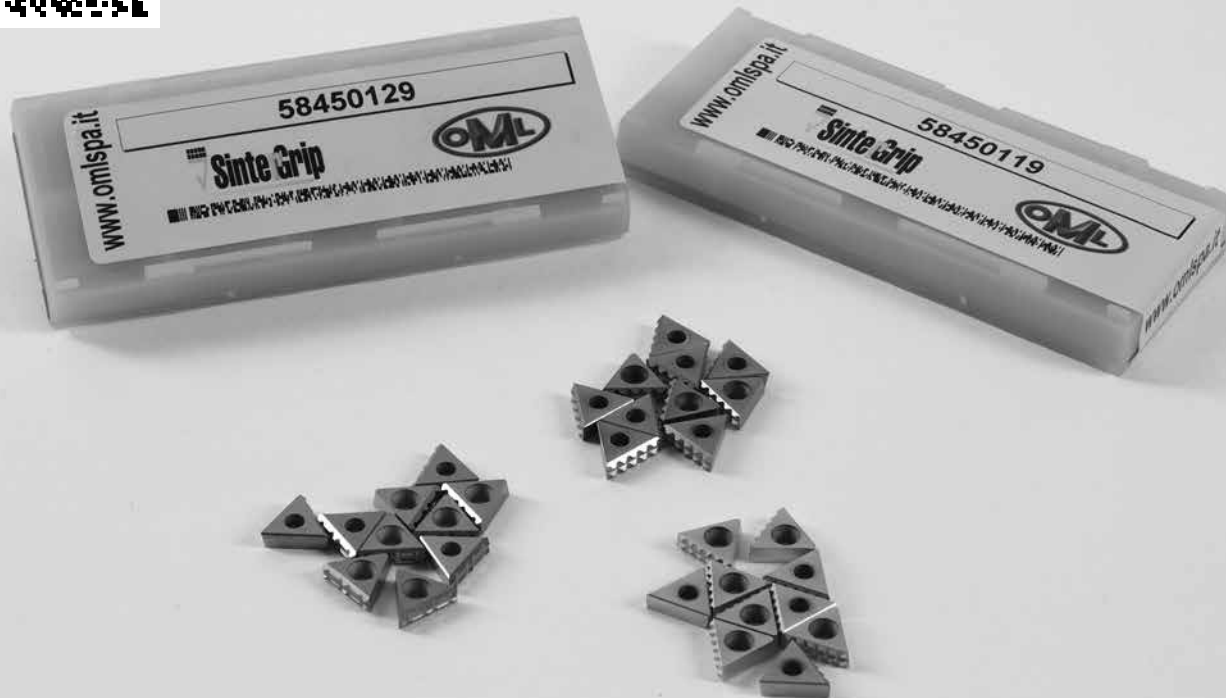



code	description
58450320	Wrench TORX T9

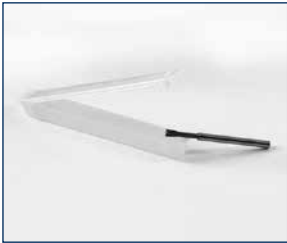

code	description
58450410	Special cutting tool D3

