

SELF-CENTERING

**Non-rotating self-centering units with manual control;
Manual static self-centering chucks,
pneumatic, hydraulic**



Y CHUCK
NC Clamping Vice

Page 12.2



PB-D
PB-C

Page 12.10



US-CL
US-A

Page 12.4



HB-D
HB-C

Page 12.12



M2-PB
M4-PB

Page 12.6

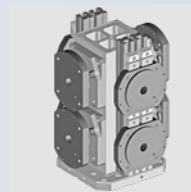

Examples

Page 12.14

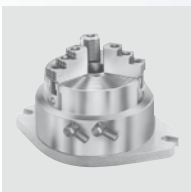

STP

Page 12.8

Y CHUCK

STATIC CHUCK

The static chuck YC joins SC range with a new feature to change in an extremely compact and strong vise.

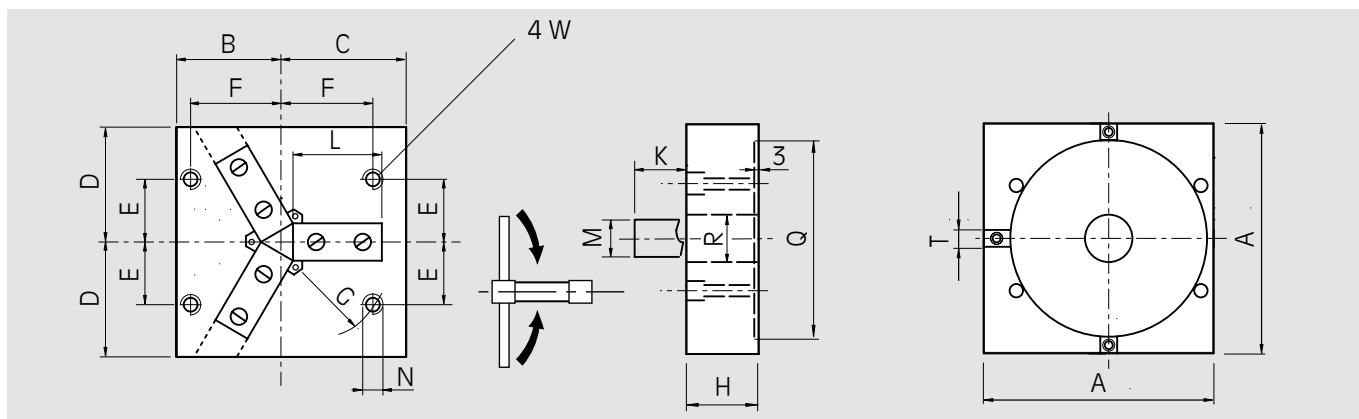

Dimensions

Id. No	type	A mm	B mm	C mm	D mm	H mm	R mm	Q mm	N mm	G mm	T mm	E mm	F mm	W mm
51 99 13 33	Y - 120	120	55	65	60	43	ø25	--	10	55	12	18	49	M 5
51 99 13 34	Y - 160	160	70	90	80	65	ø34	ø119	12	73,5	18	21	63	M 6
51 99 13 35	Y - 200	200	90	110	100	65	ø44	ø170	12	99	18	45	80	M 8
51 99 13 36	Y - 300	300	140	160	150	65	ø104	ø270	12	147	18	80	120	M 10

Specification

type	Jaw stroke	Input torque N-m	Gripping force kN	Gripping range mm	Weight kg
Y - 120	7	50	11	8 ~ 90	4,5
Y - 160	10	100	22	15 ~ 126	12
Y - 200	15	130	33	20 ~ 173	19
Y - 300	25	150	38	40 ~ 266	40

Soft-jaw dimensions

type	K mm	L mm	M mm	Id. No
Y - 120	30	60	19	51991366
Y - 160	41	70	30	51991367
Y - 200	43	85	30	51991368
Y - 300	54	115	45	51991369

Fixed jaw

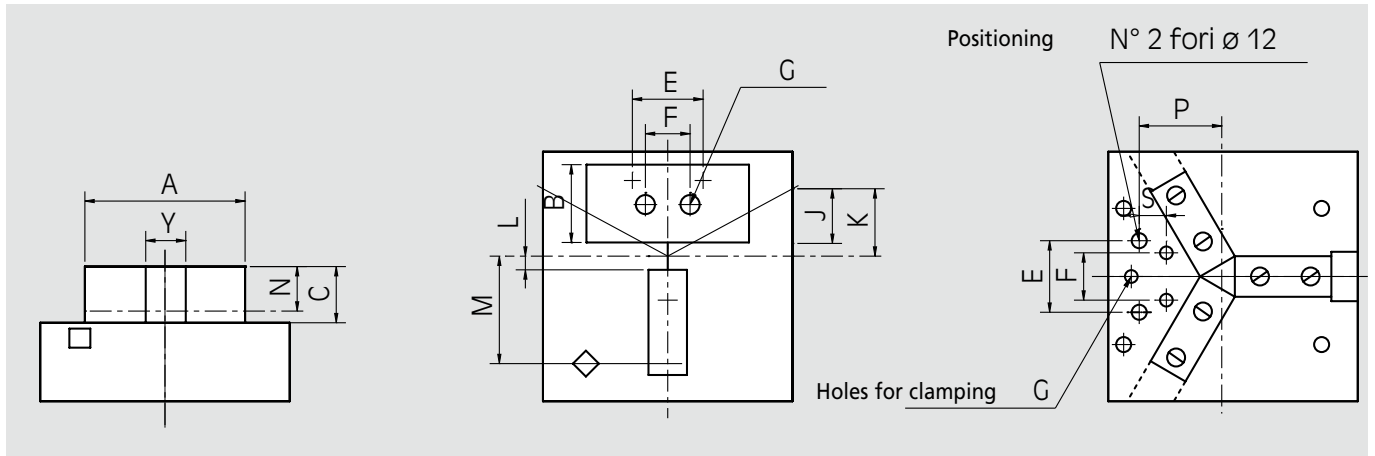

Id. No	type	A mm	B mm	C mm	E mm	F mm	G mm	N mm	Y mm	S mm	P mm	min J mm	max K mm	min L mm	max M mm
51 99 13 37	Y - 120	80	45	30	60	30	2-M6	16	18	10	45	12	45	6	55
51 99 13 38	Y - 160	100	45	41	70	30	2-M8	18	30	10	53	20	40	10	65
51 99 13 39	Y - 200	130	62	43	60	40	2-M10	20	30	20	65	15	50	10	70
51 99 13 40	Y - 300	160	115	54	60	120	3-M12	35	45	20	105	15	100	13	120

Working examples

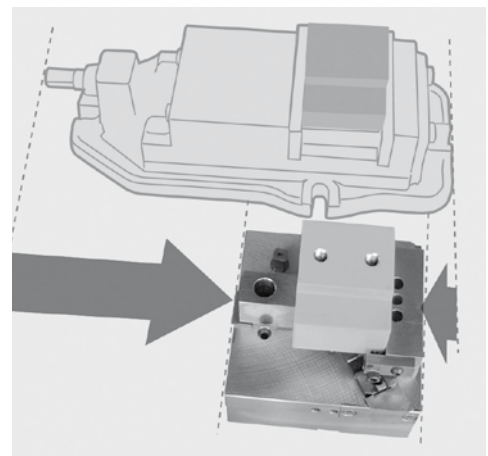
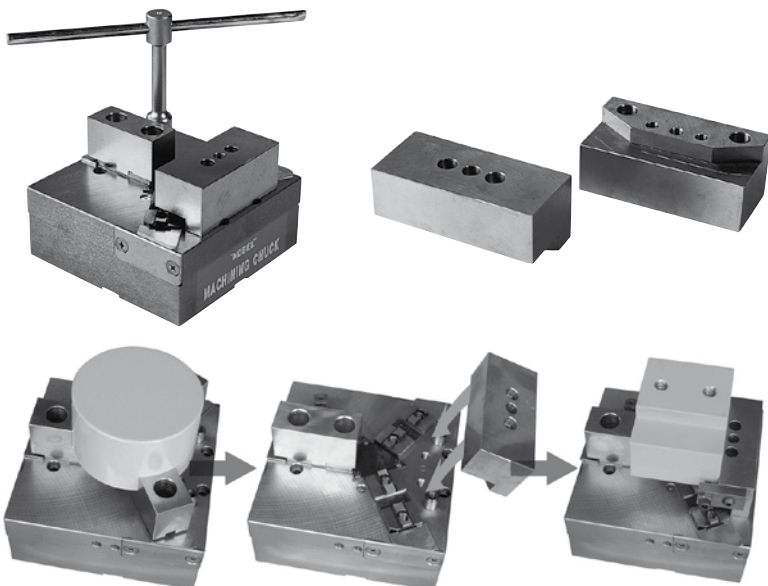

US-CL

with 2 jaw long stroke chuck

US-A

with 3 jaw long or normal stroke chuck

Static hydraulic gripping units Ø 80 - 315 mm

- Static cylinder + chuck units
- Closed center chucks type CL/AN/A

Application/customer's benefit

Gripping units designed to suit special purpose machines and transfer lines
Also used as loading chucks to handle workpieces

Technical features

Fully independent static hydraulic gripping unit with the possibility to equip the actuating cylinder with different kinds of chucks, 2 or 3 jaws, long or short stroke, serrated or tongue & groove master jaws
Aluminium cylinder housing connected to the closed center power chuck with a steel flange
The cylinder needs a constant oil feed during clamping operation

Remark: when ordering please specify the position of the oil connectors (on the side or on the back)

For chuck details please see technical details of the selected chuck

Standard equipment

Standard chuck with cylinder and connecting parts

Ordering example

US 125-CLC with rear oil connection
or
US 250-AND with side oil connection and chuck 90° revolved

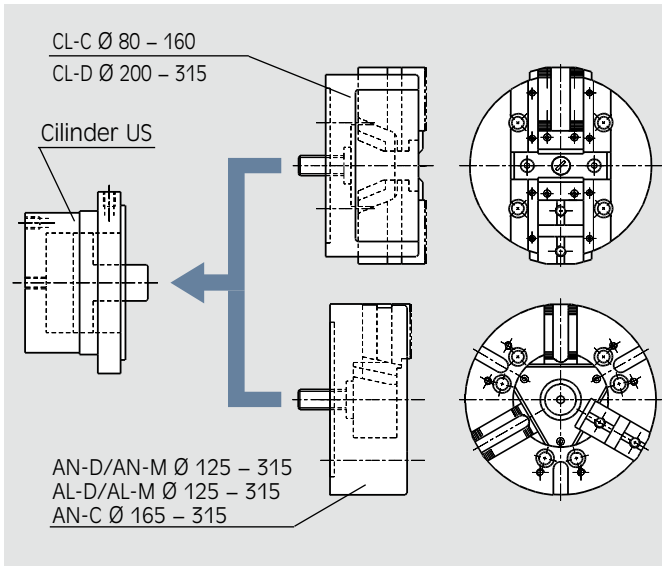

- **US-CL-C** = cylinder equipped with a 2 jaw chuck type CL-C (long stroke/tongue & groove). Chuck Ø 80 to 160 mm
- **US-CL-D** = cylinder equipped with a 2 jaw chuck type CL-D (long stroke/inch serration). Chuck Ø 200 to 315 mm
- **US-AN-D** = cylinder equipped with a 3 jaw chuck type AN-D (normal stroke/inch serration). Chuck Ø 125 to 315 mm
- **US-AN-M** = cylinder equipped with a 3 jaw chuck type AN-M (normal stroke/metric serration). Chuck Ø 125 to 315 mm
- **US-AL-D** = cylinder equipped with a 3 jaw chuck type AL-D (long stroke/inch serration). Chuck Ø 125 to 315 mm
- **US-AL-M** = cylinder equipped with a 3 jaw chuck type AL-M (long stroke/metric serration). Chuck Ø 125 to 315 mm
- **US-AN-C** = cylinder equipped with a 3 jaw chuck type AN-C (normal stroke/tongue & groove). Chuck Ø 165 to 315 mm
- **Special units** = on request the US cylinder can be equipped with other chucks, for example with a quick jaw change chuck type **AN-RM** with stationary cylinder available

CL chuck in standard position

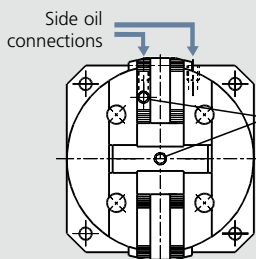

CL chuck 90° revolved

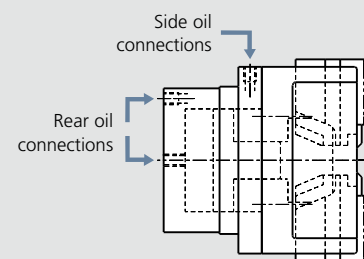
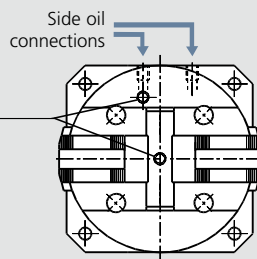

AN/AL chuck in standard position

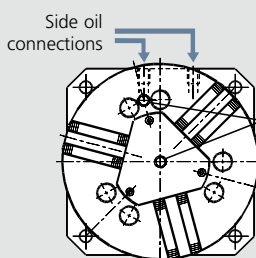

AN/AL chuck 90° revolved

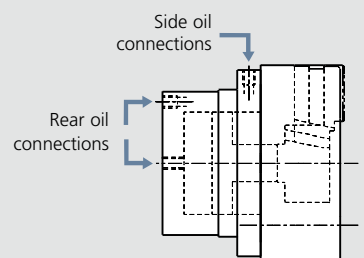
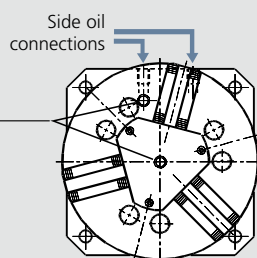

■ The chuck can be mounted on the cylinder 90° revolved if the standard position creates interferences with the working cycle. Please specify in the order, if a revolved position is needed.

■ The oil connections can be on the side or on the back of the cylinder in order to ease the installation of the gripping unit. Please specify in the order, which version is preferred.

- Static cylinder + chuck units
- Closed center chucks type CL/AN/A

with 2 jaw long stroke chuck

with 3 jaw long or normal stroke chuck

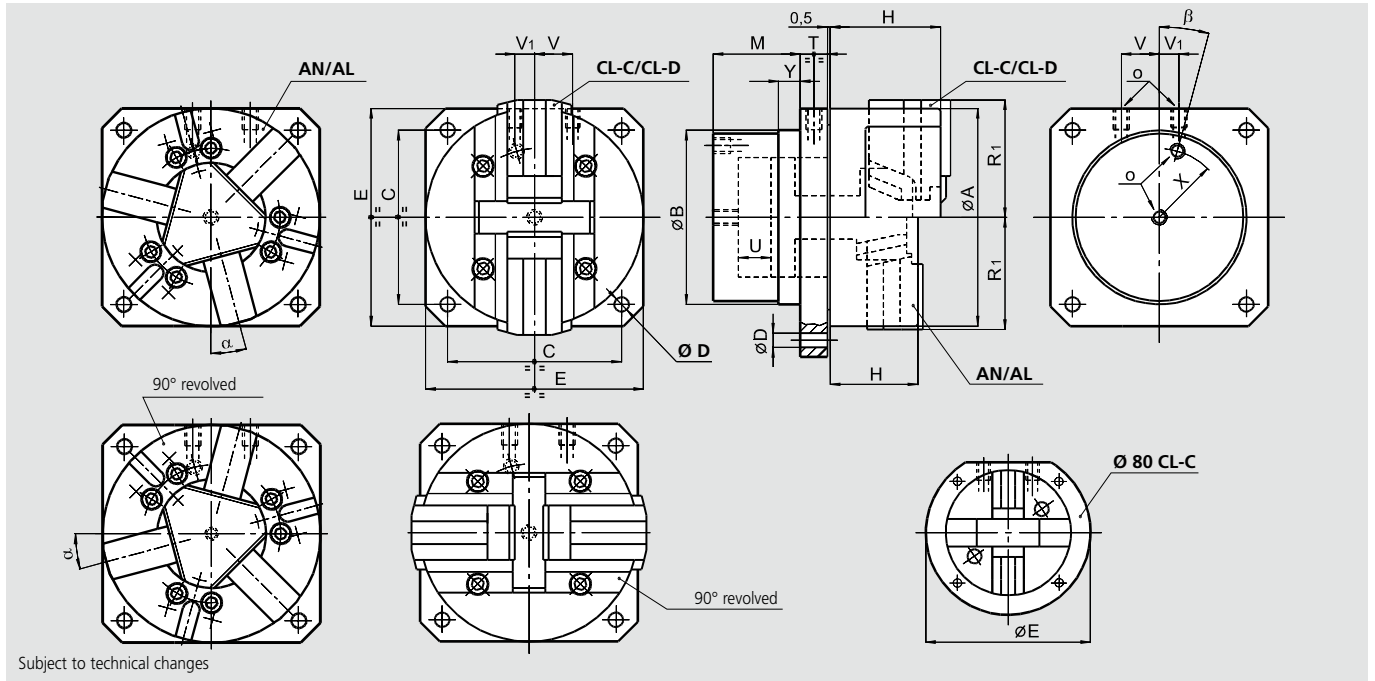

US actuating cylinder dimensions

SMW-AUTOBLOK cylinder		US 80	US 100	US 125	US 160 US 165	US 200	US 250	US 315
Id. No.		77755008	77755010	77755013	77755016	77755120	77755025	77755031
B h7	mm	70	84	106	128	158	185	185
C	mm	66	84	104	130	160	200	250
D	mm	7	9	11	11	13,5	17	17
E	mm	105	100	130	160	200	250	315
M	mm	45	52	60	70	80	90	90
O	oil connections	inch	1/8 BSP	1/8 BSP	1/4 BSP	3/8 BSP	3/8 BSP	3/8 BSP
T	mm	16	16	20	20	25	25	25
U	mm	11	14	20	25	30	35	35
V	mm	15	18	12	28	35	41	41
V1	mm	15	18	12	15	18	15	15
X	mm	27	33	43	52	63	75	75
Y	mm	10	10	10	20	20	20	20
α	deg.	30°	30°	15°	15°	0°	0°	0°
Piston area	cm ²	16	25	42	68	112	166	166

Units with CL-C and CL-D chucks

SMW-AUTOBLOK Type		US 80-CL-C	US 100-CL-C	US 125-CL-C	US 160-CL-C	US 200-CL-D	US 250-CL-D	US 315-CL-D
A	mm	80	100	125	160	200	250	315
H	mm	45	54	76	92	103	109	114
Chuck open	R1	mm	40	50	68	87	108	166
Max. pressure	bar	38	36	36	37	32	30	36
Max. gripping force	kN	9	14	24	40	55	78	95

Units with AN-D/AN-M/AN-C chucks

SMW-AUTOBLOK Type		US 125-AN-D US 125-AN-M	US 165-AN-D US 165-AN-M US 165-AN-C	US 210-AN-D US 210-AN-M US 210-AN-C	US 250-AN-D US 250-AN-M US 250-AN-C	US 315-AN-D US 315-AN-M US 315-AN-C
A	mm	127	165	210	254	315
H	mm	57	71	85	95	105
Chuck open	R1	mm	64	83	105	128
	α	deg.	0°	15°	15°	15°
Max. pressure	bar	47	36	31	28	36
Max. gripping force	kN	56	70	105	140	180

Units with AL-D/AL-M chucks

SMW-AUTOBLOK Type		US 125-AL-D US 125-AL-M	US 165-AL-D US 165-AL-M	US 210-AL-D US 210-AL-M	US 250-AL-D US 250-AL-M	US 315-AL-D US 315-AL-M
A	mm	127	165	210	254	315
H	mm	57	71	85	95	105
Chuck open	R1	mm	67	86	109	133
	α	deg.	0°	15°	15°	15°
Max. pressure	bar	60	44	45	39	45
Max. gripping force	kN	45	54	90	120	135

M2-PB

M4-PB

Pneumatic multiple fixtures for machining centers

Multiple fixture with 2 chucks

Multiple fixture with 4 chucks

- Ø 130 - 315 mm
- 2 or 3 jaws (PB-D / PB-M)
- 3 jaws (PB-C)



Application/customer's benefit

Multiple self centering chuck fixtures used on milling machines or machining centers to clamp and machine multiple pieces in one set-up

M2-PB: Multiple fixture with 2 chucks type PB-D, PB-C or PB-M

M4-PB: Multiple fixture with 4 chucks type PB-D, PB-C or PB-M

Technical features (more features on chucks see pag. 9.2.20)

The basic model needs separate circuits to operate the chucks singularly

1st option: SAB safety unit with non-return valve for every chuck

2nd option: single non-return valve to operate all chucks simultaneously, with coupling unit to repressurize the fixtures after the storage of the pallets

3rd option: every chuck can be equipped with a spring loaded clamping unit (internal or external clamping), to hold the workpieces during the pallet transfer

Standard equipment

- Multiple chuck fixture
- 1 set of soft blank top jaws per chuck (PB-C excluded)
- Grease gun

Ordering example

- Multiple chuck fixture
- M2-PBC 250 (3 jaws)
- or
- Multiple chuck fixture
- M4-PBD 165 (2 jaws)

Technical data

SMW-AUTOBLOK Type Code		M2-PBD 3 (3 jaws) 130 77272513	M2-PBD 3 (3 jaws) 165 77272516	M2-PBD 3 (3 jaws) 210 77272521	M2-PBD 3 (3 jaws) 250 77272525	M2-PBD 3 (3 jaws) 315 77272531
SMW-AUTOBLOK Type Code		M2-PBLD 2 (2 jaws) 130 77272713	M2-PBLD 2 (2 jaws) 165 77272716	M2-PBLD 2 (2 jaws) 210 77272721	M2-PBLD 2 (2 jaws) 250 77272725	M2-PBLD 2 (2 jaws) 315 77272731
SMW-AUTOBLOK Type Code		N.D.	M2-PBC 3 (3 jaws) 165 77277916	M2-PBC 3 (3 jaws) 210 77277921	M2-PBC 3 (3 jaws) 250 77277925	M2-PBC 3 (3 jaws) 315 77277931
Chucks radial jaw stroke	mm	3.2	3.6	4.4	5	6.3
Chucks radial jaw stroke PBL-D2 (2 jaws)*	mm	6	6.8	8.4	9.7	12
Actuating cylinder piston area	cm²	82	143	236	358	548
Max. operating pressure	bar	7	7	7	7	7
Chucks gripping force at 6 bar	kN	14	24	42	64	98
Chucks gripping force at 6 bar PBL-D2 (2 jaws)*	kN	9	16	26	39	60
M2-PB. mass (without top jaws)	kg	29.5	49	83	121	172

* The 2 jaw fixture is available with serrated master jaws (inch or metric) and long stroke only.

Option for the M2-PB and M4-PB fixtures
Safety unit that maintains a constant pressure inside the cylinder which maintains a steady clamping force even in case of a drop or lack of line pressure

SAB Safety unit with double non-return valve - Code 27581620.

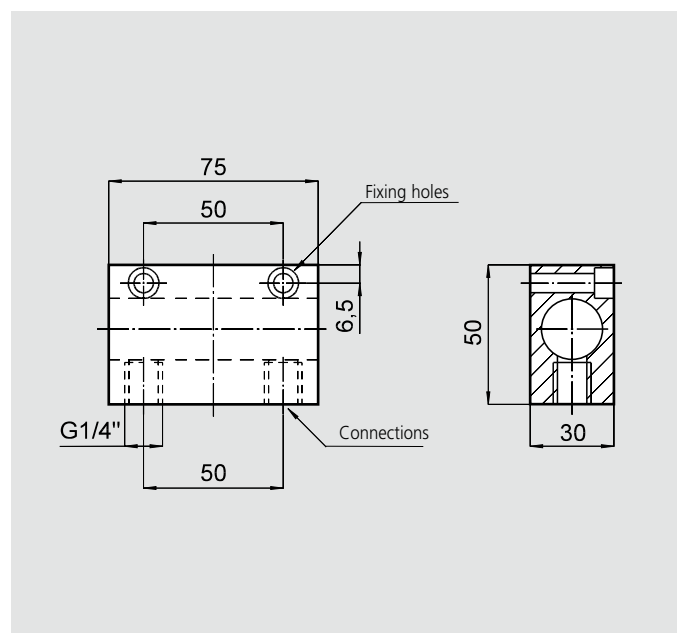

- Ø 130 - 315 mm
- 2 or 3 jaws (PB-D / PB-M)

- 3 jaws (PB-C)

Multiple fixture with 2 chucks

Multiple fixture with 4 chucks

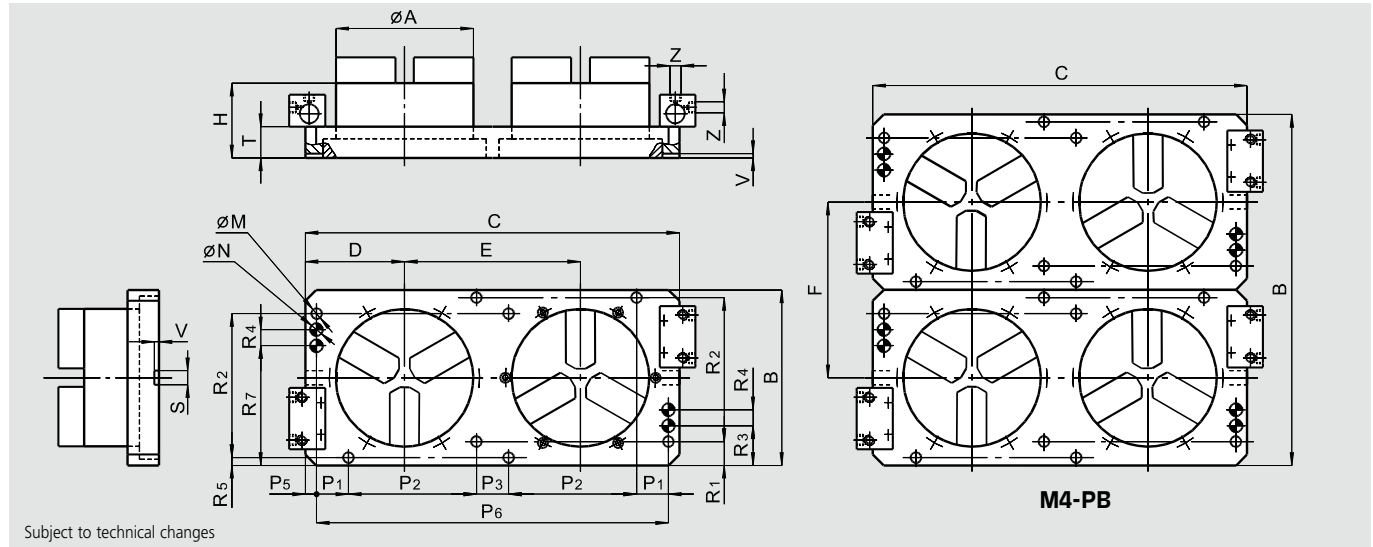

M2-PB dimensions

SMW-AUTOBLOK Type			M2-PB 130	M2-PB 165	M2-PB 210	M2-PB 250	M2-PB 315
Chuck diameter	A	mm	135	170	215	260	315
	B	mm	198	224	274	324	374
	C	mm	400	460	585	660	780
	D	mm	107.5	131	155	175	205
	E	mm	185	223	275	310	370
	H	mm	89	100	117	127	141
Fixing holes diameter	M	mm	17	17	17	17	17
	N H8	mm	20	20	20	20	20
Reference pin holes	P1	mm	-	50	50	50	50
	P2	mm	150	150	200	250	300
	P3	mm	50	50	50	-	-
	P5	mm	25	17.5	17.5	30	40
	P6	mm	350	460	550	600	700
	R1	mm	24	37	37	37	37
	R2	mm	150	175	225	275	325
	R3	mm	24	62	62	62	62
	R4	mm	-	25	25	25	25
	R5	mm	24	12	12	12	12
	R7	mm	174	137	187	237	287
S	mm	14	18	18	18	18	
T	mm	39	44	49	54	54	
V	mm	6	6	6	6	6	
Pneumatic connections	Z	inch	R1/4"	R1/4"	R1/4"	R1/4"	R1/4"

M4-PB dimensions

SMW-AUTOBLOK Type			M4-PB 130	M4-PB 165	M4-PB 210	M4-PB 250	M4-PB 315
Chuck diameter	A	mm	135	170	215	260	315
	B	mm	398	449	549	649	749
	C	mm	400	460	585	660	780
	D	mm	107.5	131	155	175	205
	E	mm	185	223	275	310	370
	F	mm	200	225	275	325	375
Fixing holes diameter	M	mm	17	17	17	17	17
	N H8	mm	20	20	20	20	20
Reference pin holes	P1	mm	-	50	50	50	50
	P2	mm	150	150	200	250	300
	P3	mm	50	50	50	-	-
	P5	mm	25	17.5	17.5	30	40
	P6	mm	350	460	550	600	700
	R1	mm	24	37	37	37	37
	R2	mm	150	175	225	275	325
	R3	mm	24	62	62	62	62
	R4	mm	-	25	25	25	25
	R5	mm	24	12	12	12	12
	R7	mm	174	137	187	237	287
S	mm	14	18	18	18	18	
T	mm	39	44	49	54	54	
V	mm	6	6	6	6	6	
Pneumatic connections	Z	inch	R1/4"	R1/4"	R1/4"	R1/4"	R1/4"

- Ø 125 - 280 mm
- with THROUGH-HOLE



Application/customer's benefit

Self centering chuck fixtures used on milling machines, machining centers or special machines. Low profile – large open center
Easy installation on the machine

Technical features

Independent units consisting of a 3 jaw chuck with a built in pneumatic cylinder
Relevant gripping force and very high precision
Operating pressure from 2 to 10 bar

Caution! Operating air must be filtered and oiled, to prevent any damage to the seals

Standard equipment

- 3 jaw chuck
- 1 set T-nuts with bolts
- 1 set of soft blank top jaws
- 2 elbow fittings G1/4"
- (G1/8" on STP 125)

Ordering example

- 3 jaw chuck fixture STP 280
- or
- 3 jaw chuck fixture STP 160

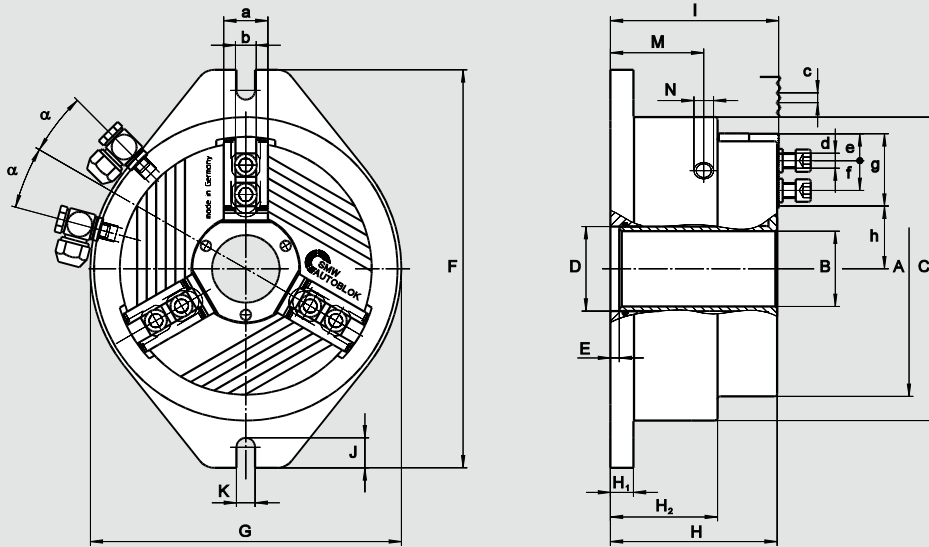

Subject to technical changes

SMW-AUTOBLOK Type			STP 125	STP 160	STP 240	STP 280
Id. No.			013904	013905	053273	052810
	A	mm	136	171	240	284
	B	mm	26	38	78	92
	C	mm	156	201	250	316
	D H6	mm	34	46	86	102
	E	mm	8	7.5	7	6
	F	mm	220	275	320	400
	G	mm	160	206	250	316
	H	mm	102.5	130	134	155.5
	H1	mm	14.5	19	18.5	23.5
	H2	mm	66	83	86	97.5
	I	mm	104	132	135.5	157
	J	mm	22	24	24	30
	K	mm	13	15	15	18
	M	mm	57	72	75	86
Pneumatic connections	N	inch	G 1/8"	G 1/4"	G 1/4"	G 1/4"
	a	mm	25	30	36	44
	b f7	mm	12	14	17	21
Serration	c	inch	1/16" x 90°	1/16" x 90°	1/16" x 90°	1/16" x 90°
Bolt DIN 912 12.9	d	mm	M8 x 30	M10 x 35	M12 x 35	M16 x 40
	e	mm	4	6	8	12
T-nuts distance	f	mm	17/25	17/31	22/41.5	25/51
Serration length	g	mm	40	50	59	75
	h	mm	25.9/28.9	24.9/37	57.7/61.9	70/65
	α		15	15	15	7.5
Radial jaw stroke		mm	3	4.1	4.2	5
Operating pressure	min./max.	bar	2/10	2/10	2/10	2/10
Piston area		cm ²	129	206	290	532
Air consumption at 6 bar		l	1	2.4	5.5	6.6
Mass (without top jaws)		kg	19	21	40	56

MHB-D
Hard reversible top jaws

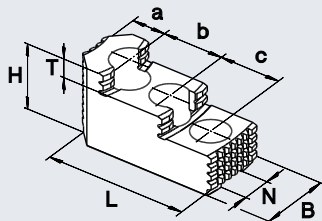

Chuck type	STP 125	STP 160	STP 240	STP 280
Jaw type	MHB-D 125	MHB-D 160	MHB-D 200	MHB-D 251
Jaw Id. No. (set)	12081306	12081636	12082036	12083036
B	30	34	40	5
H	34	39	45	56
L	58	65	82	105
T	8.5	10	10.5	13.5
N	12	14	17	21
Serration	1/16" x 90°	1/16" x 90°	1/16" x 90°	1/16" x 90°
a	13	18	19	26
b	16	16	23	30
c	16	16	23	30
kg/set	0.6	0.9	1.7	2.85

AWB-D
Soft top jaws

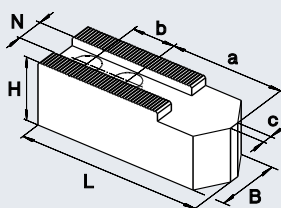

Chuck type	STP 125	STP 160	STP 240	STP 280
Jaw type	AWB-D 125	AWB-D 165	AWB-D 200	AWB-D 250
Jaw Id. No. (set)	12071300	035954	081616	081618
B	30	40	40	50
H	30	40	40	50
L	60	80	90	120
N	12	14	17	21
Serration	1/16" x 90°	1/16" x 90°	1/16" x 90°	1/16" x 90°
a	29	43	53	70
b	16	22	22	28
kg/set	0.9	2.0	2.7	5.1

NST T-nuts

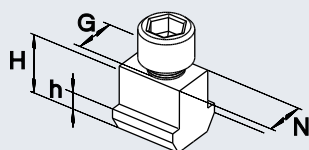

Chuck type	STP 125	STP 160	STP 240	STP 280
T-nut type	NST 12	NST 14	NST 17-4	NST 21-5
T-nut Id. No.	089810	013863	013864	033429
N	12	14	17	21
H	21.5	26.5	26.5	30
h	7.5	9.5	9.5	11
G	M8	M10	M12	M16
Bolt DIN 912 12.9	M8 x 30	M10 x 35	M12 x 35	M16 x 40
Tighten torque	30	50	70	150

PB-D

INCH serration
2 or 3 jaws

PB-C

Tongue & groove
3 jaws

Pneumatic chuck fixtures with built-in cylinder

- Ø 130 - 315 mm
- 2 or 3 jaws



Application/customer's benefit

Self centering chuck fixtures used on milling machines, machining centers or special machines

- PB-D:** inch serrated master jaws (1/16" x 90°)
- PB-C:** tongue & groove master jaws (American standard)
- PB-M:** metric serrated master jaws (1.5 mm x 60°) **on request**

Technical features

Independent units consisting of a 2/3 jaw chuck with a built in pneumatic cylinder
 Reduced overall dimensions on the machine
 High gripping force and very high precision
 Case hardened body to assure highest precision and long chuck life
Caution! Operating air must be filtered and oiled, to prevent any damage to the seals

Standard equipment

- Clamping unit
- 1 set of soft blank top jaws (PB-C excluded)
- Grease gun

Ordering example

- 3 jaw chuck fixture PB-C 250
- or
- 2 jaw chuck fixture PBL-D2 165

Technical data

SMW-AUTOBLOK Type Code		PB-D 3 (3 jaws) 130 77270713	PB-D 3 (3 jaws) 165 77270716	PB-D 3 (3 jaws) 210 77270721	PB-D 3 (3 jaws) 250 77270725	PB-D 3 (3 jaws) 315 77270731
SMW-AUTOBLOK Type Code		PBLD 2 (2 jaws) 130 77271313	PBLD 2 (2 jaws) 165 77271316	PBLD 2 (2 jaws) 210 77271321	PBLD 2 (2 jaws) 250 77271325	PBLD 2 (2 jaws) 315 77271331
SMW-AUTOBLOK Type Code		PB-C 3 (3 jaws) 130 N.D.	PB-C 3 (3 jaws) 165 77276816	PB-C 3 (3 jaws) 210 77276821	PB-C 3 (3 jaws) 250 77276825	PB-C 3 (3 jaws) 315 77276831
Radial jaw stroke	mm	3.2	3.6	4.4	5	6.3
Radial jaw stroke PBL-D2 (2 jaws)*	mm	6	6.8	8.4	9.7	12
Piston area	cm²	82	143	236	358	548
Max. operating pressure	bar	7	7	7	7	7
Gripping force at 6 bar	kN	14	24	42	64	98
Gripping force at 6 bar PBL-D2 (2 jaws)*	kN	9	16	26	39	60
Mass (without top jaws)	kg	9	17	28	42	63

*The 2 jaw fixture is available with serrated master jaws (inch or metric) and long stroke only.

Option for the PB-D and PB-C chuck
Safety unit that maintains a constant pressure inside the cylinder which maintains a steady clamping force even in case of a drop or lack of line pressure

SAB Safety unit with double non-return valve

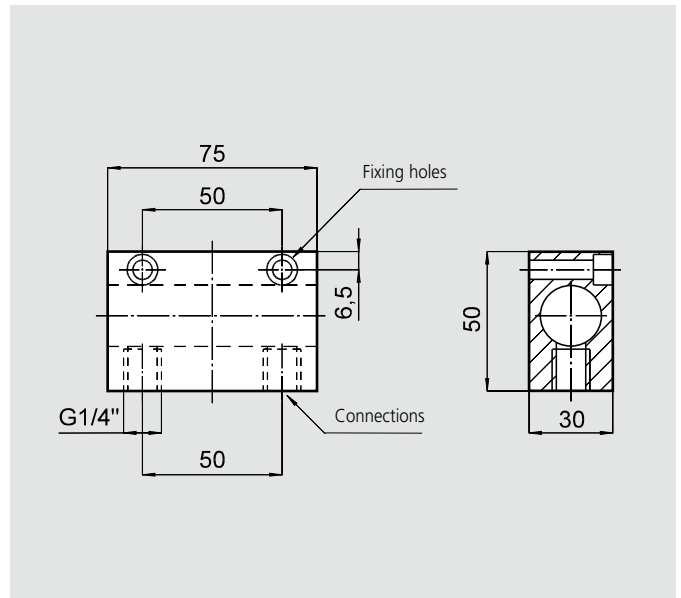

- Ø 130 - 315 mm
- 2 or 3 jaws

INCH serration
2 or 3 jaws

Tongue & groove
3 jaws

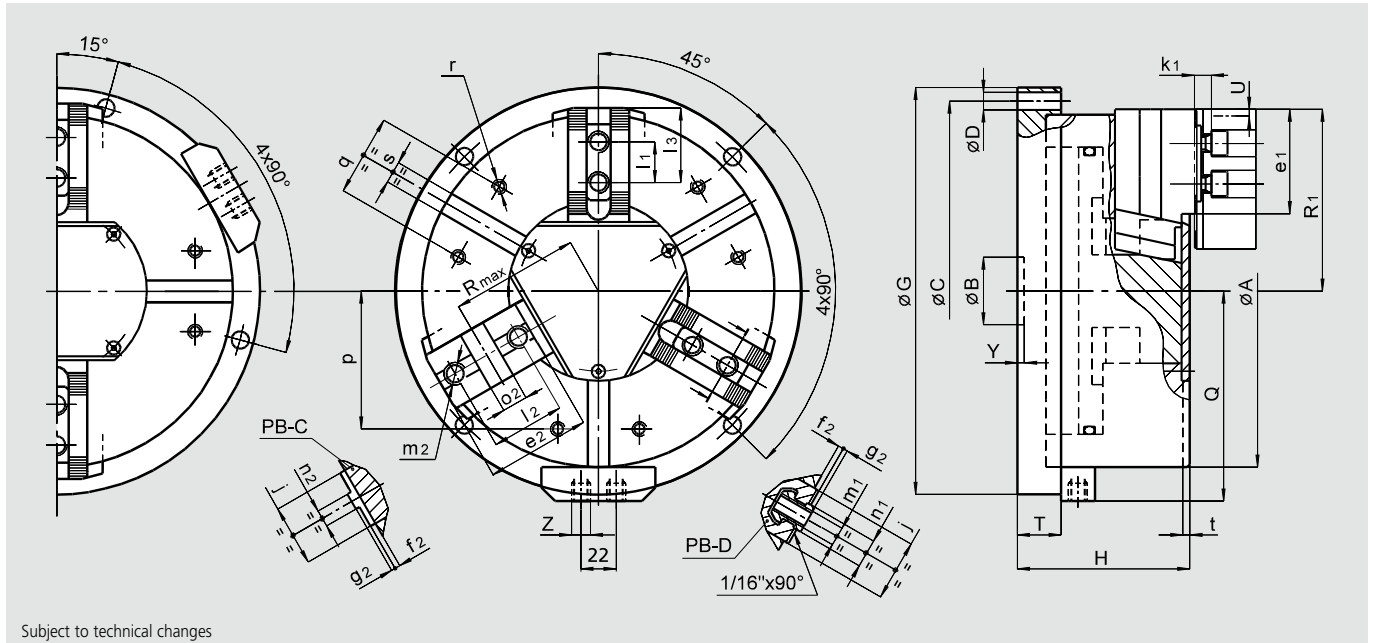

Common dimensions

SMW-AUTOBLOK Type		PB-D 130 PB-C 130	PB-D 165 PB-C 165	PB-D 210 PB-C 210	PB-D 250 PB-C 250	PB-D 315 PB-C 315	
	A	mm	135	170	215	260	315
	B	mm	30	30	35	50	50
Fixing holes circle	C	mm	155	190	235	280	340
Fixing holes diameter	D	mm	9	11	11	13	13
	G	mm	175	210	255	300	360
	H	mm	89	100	117	127	141
	Q	mm	93	110	133	155	183
Radial jaw stroke (3 jaws)	T	mm	25	27	30	32	32
Radial jaw stroke PBL-D2 (2 jaws)	U	mm	3.2	3.6	4.4	5	6.3
	U	mm	6	6.8	8.4	9.7	12
	Y	mm	5	5	5	5	5
Pneumatic connections	Z	inch	R1/4"	R1/4"	R1/4"	R1/4"	R1/4"
	j	mm	26	30	36	45	45
	k1	mm	10	10	11	12	12
	p	mm	52	65	80	102	120
	q	mm	30	36	45	60	60
	r	mm	M6	M8	M8	M10	M10
	s H12	mm	12	16	16	16	16
	t	mm	5	5	5	5	5

PB-D and PBL-D2 fixtures dimensions

SMW-AUTOBLOK Type		PB-D 130	PB-D 165	PB-D 210	PB-D 250	PB-D 315	
	e1	mm	37	48	60	77	99
	f1	mm	3	4	3	4	4
	g1	mm	2.5	2.5	2.5	3.5	3.5
	h1	mm	16	16.5	23	30	30
T-nut position min./max.	l3	mm	23/30	24/40	33/50	43/62	43/84
	m1	mm	M8	M10	M12	M16	M16
	n1 h8	mm	12	14	17	21	21
Chuck open (3 jaw)	R1	mm	71	89	110	134	162
Chuck open PBL-D2 (2 jaws)	R1	mm	74	92	114	138.5	168

PB-C fixtures dimensions (available only in 3 jaw chuck version)

SMW-AUTOBLOK Type		PB-C 130	PB-C 165	PB-C 210	PB-C 250	PB-C 315	
	e2	mm	-	54	71	99	
	f2	mm	-	4	4	4	
	g2	mm	-	3	3	3	
	l2	mm	-	38	44.4	54	63.5
	m2	mm	-	M10	M12	M16	M16
	n2 h8	mm	-	7.94	7.94	12.70	12.70
	o2 H7	mm	-	12.68	12.68	19.03	19.03
Chuck open	R1	mm	-	89	110	134	162
Chuck open	Rmax	mm	-	62	77	94	109

HB-DINCH serration
2 or 3 jaws**HB-C**Tongue & groove
3 jaws**Hydraulic chuck fixtures with built-in cylinder**

- Ø 130 - 315 mm
- 2 or 3 jaws

**Application/customer's benefit**

Self centering chuck fixtures used on milling machines, machining centers or special machines

HB-D: inch serrated master jaws (1/16" x 90°)

HB-C: tongue & groove master jaws (American standard)

HB-M: metric serrated master jaws (1.5 mm x 60°) **on request**

Technical features

Independent units consisting of a 2/3 jaw chuck with an built in hydraulic cylinder

Reduced overall dimensions on the machine

High gripping force and very high precision

Case hardened body to assure highest precision and long chuck life

Standard equipment

Clamping unit

1 set T-nuts with bolts (HB-C excluded)

Grease gun

Ordering example

3 jaw chuck fixture HB-C 250

or

2 jaw chuck fixture HBL-D2 165

Technical data

SMW-AUTOBLOK Type Code		HB-D 3 (3 jaws) 130 77271113	HB-D 3 (3 jaws) 165 77271116	HB-D 3 (3 jaws) 210 77271121	HB-D 3 (3 jaws) 250 77271125	HB-D 3 (3 jaws) 315 77271131
SMW-AUTOBLOK Type Code		HBL-D 2 (2 jaws) 130 77271713	HBL-D 2 (2 jaws) 165 77271716	HBL-D 2 (2 jaws) 210 77271721	HBL-D 2 (2 jaws) 250 77271725	HBL-D 2 (2 jaws) 315 77271731
SMW-AUTOBLOK Type Code		HB-C 3 (3 jaws) 130 N.D.	HB-C 3 (3 jaws) 165 77277516	HB-C 3 (3 jaws) 210 77277521	HB-C 3 (3 jaws) 250 77277525	HB-C 3 (3 jaws) 315 77277531
Radial jaw stroke	mm	2.8	3.2	4	4.6	5.5
Radial jaw stroke HBL-D2 (2 jaws)*	mm	5.2	6	7.5	8.8	10.5
Piston area	cm ²	59	79	114	167	203
Max. operating pressure	bar	30	30	30	30	30
Gripping force at 25 bar	kN	42	55	85	125	150
Gripping force at 25 bar HBL-D2 (2 jaws)*	kN	26	35	52	75	90
Mass (without top jaws)	kg	10	18	30	44	69

*The 2 jaw fixture is available with serrated master jaws (inch or metric) and long stroke only.

- Ø 130 - 315 mm
- 2 or 3 jaws

INCH serration
2 or 3 jaws

Tongue & groove
3 jaws

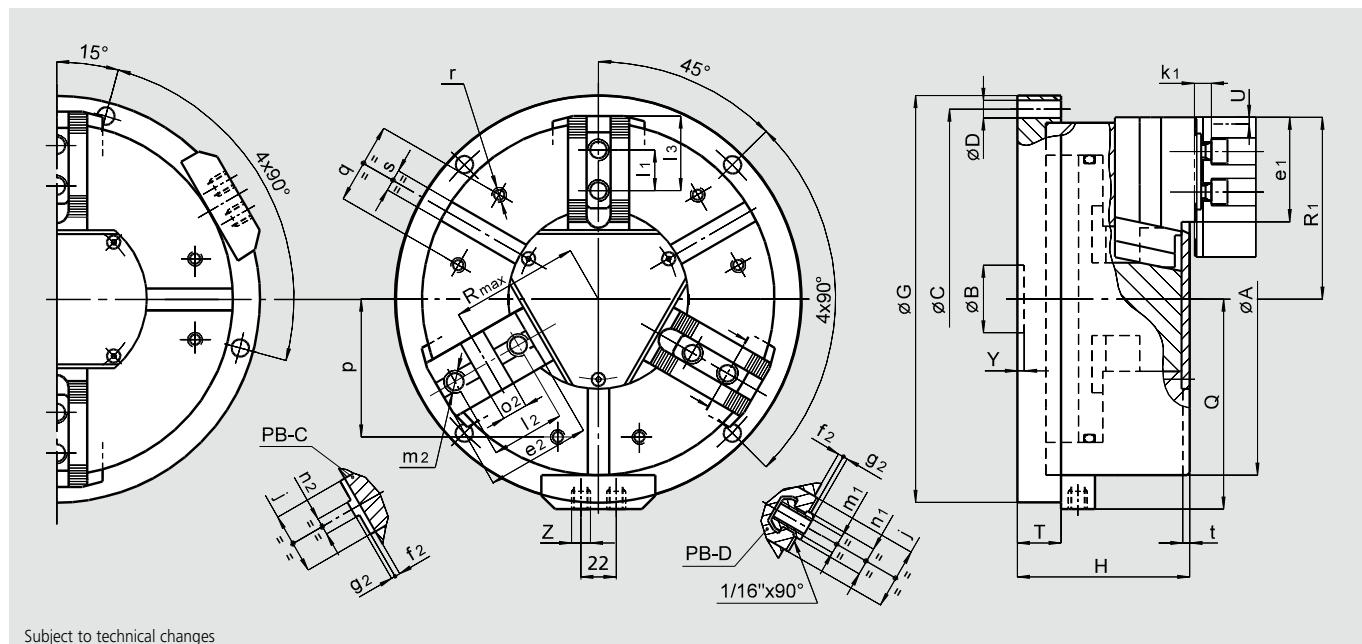

Subject to technical changes

Common dimensions

SMW-AUTOBLOK Type		HB-D 130 HB-C 130	HB-D 165 HB-C 165	HB-D 210 HB-C 210	HB-D 250 HB-C 250	HB-D 315 HB-C 315	
	A	mm	135	170	215	260	315
	B	mm	30	30	35	50	50
Fixing holes circle	C	mm	155	190	235	280	340
Fixing holes diameter	D	mm	9	11	11	13	13
	G	mm	175	210	255	300	360
	H	mm	89	100	117	127	141
	Q	mm	93	110	133	155	183
Radial jaw stroke (3 jaws)	T	mm	25	27	30	32	32
Radial jaw stroke HBL-D2 (2 jaws)	U	mm	2.8	3.2	4	4.6	5.5
	U	mm	5.2	6	7.5	8.8	10.5
	Y	mm	5	5	5	5	5
Hydraulic connections	Z	inch	R1/4"	R1/4"	R1/4"	R1/4"	R1/4"
	j	mm	26	30	36	45	45
	k1	mm	10	10	11	12	12
	p	mm	52	65	80	102	120
	q	mm	30	36	45	60	60
	r	mm	M6	M8	M8	M10	M10
	s H12	mm	12	16	16	16	16
	t	mm	5	5	5	5	5

HB-D and HBL-D2 fixtures dimensions

SMW-AUTOBLOK Type		HB-D 130	HB-D 165	HB-D 210	HB-D 250	HB-D 315	
	e1	mm	37	48	60	77	99
	f1	mm	3	4	3	4	4
	g1	mm	2.5	2.5	2.5	3.5	3.5
	h1	mm	16	16.5	23	30	30
T-nut position	min./max.	mm	23/30	24/40	33/50	43/62	43/84
	m1	mm	M8	M10	M12	M16	M16
	n1 h8	mm	12	14	17	21	21
Chuck open (3 jaws)	R1	mm	71	89	110	134	162
Chuck open HBL-D2 (2 jaws)	R1	mm	74	92	114	138.5	168

HB-C fixtures dimensions (available only in 3 jaw chuck version)

SMW-AUTOBLOK Type		HB-C 130	HB-C 165	HB-C 210	HB-C 250	HB-C 315	
	e2	mm	-	54	71	99	
	f2	mm	-	4	4	4	
	g2	mm	-	3	3	3	
	l2	mm	-	38	44.4	54	63.5
	m2	mm	-	M10	M12	M16	M16
	n2 h8	mm	-	7.94	7.94	12.70	12.70
	o2 H7	mm	-	12.68	12.68	19.03	19.03
Chuck open	R1	mm	-	89	110	134	162
Chuck open	Rmax	mm	-	62	77	94	109

EXAMPLES

