

SPEEDY VISE - TC HYDRO

Pneumatic and pneumo-hydraulic equipment



SPEEDY VISE

Pneumatic quick clamping equipment

Pag. 13.2

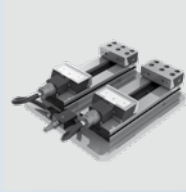

TC HYDRO

Set of modular clamping equipment with hydraulic clamping unit

Pag. 13.5

FEATURES

1. Robust construction of one piece casting of fixed jaw and vise bed.
2. Rigid and high tensile casting of ductile iron FCD60JIS (equal to GGG60) with 60 kg/mm² or 80.000 psi tensile strength.
3. Most suitable for mass production and to be used on machine centres, milling machines, drilling machines and special purpose machines.
4. Most compact pneumatic mechanism design. No oil, just joint the air supply will do.
5. Most compact in total length of vise with max clamping capacity.
6. Safety locking mechanism for unexpected termination of air supply. After pneumatic clamping, the workpiece will be clamped firmly even without the air supply.
7. Easy and simple ON-OFF switch control for pneumatic operation. The optional electric control for automatic and FMS system is available.
8. Safety protection max. pneumatic clamping stroke is 4 mm. (Adjust the stroke at 2 mm for a better power capacity)
9. Rapid ON-OFF only 1,5 sec.
10. Multiply pneumatic Quick Vise set up available with only one source of air supply (optional).
11. Free adjusting of max. pneumatic clamping pressure (see graphs) using the air regulator placed nearby the pressure control gauge.
12. Vise bed flame hardened to HRC 45°.
13. Down trust "semi-spherical segment" mechanism eliminates jaw lifting and workpiece.

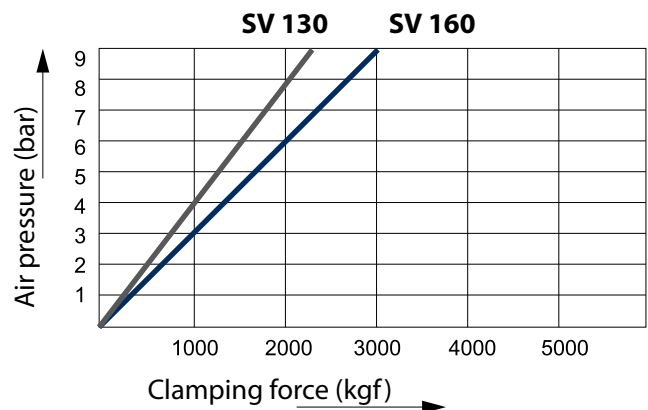
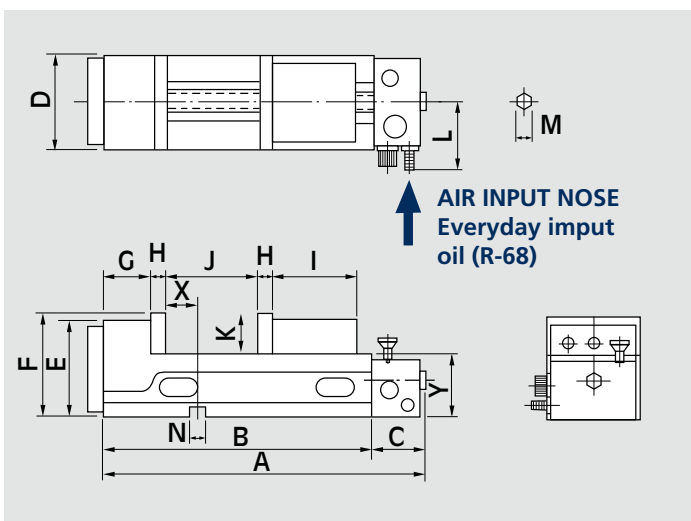

Id. no.	Type	A mm	B mm	C mm	D mm	E mm	F mm	G mm	H mm	I mm	J mm	K mm	L mm	M mm	N mm	X mm	Y mm
77 58 91 21	SV 130	507	405	102	131	152	155	100	15	115	0-140	55	95	14	18	65	100
77 58 92 21	SV 160	534	432	102	161	160	163	115	15	130	0-150	58	105	14	18	65	105

■ MOST SUITABLE FOR MASS PRODUCTION ON MACHINE CENTRE



ALWAYS USE FILTERED COMPRESSED AIR

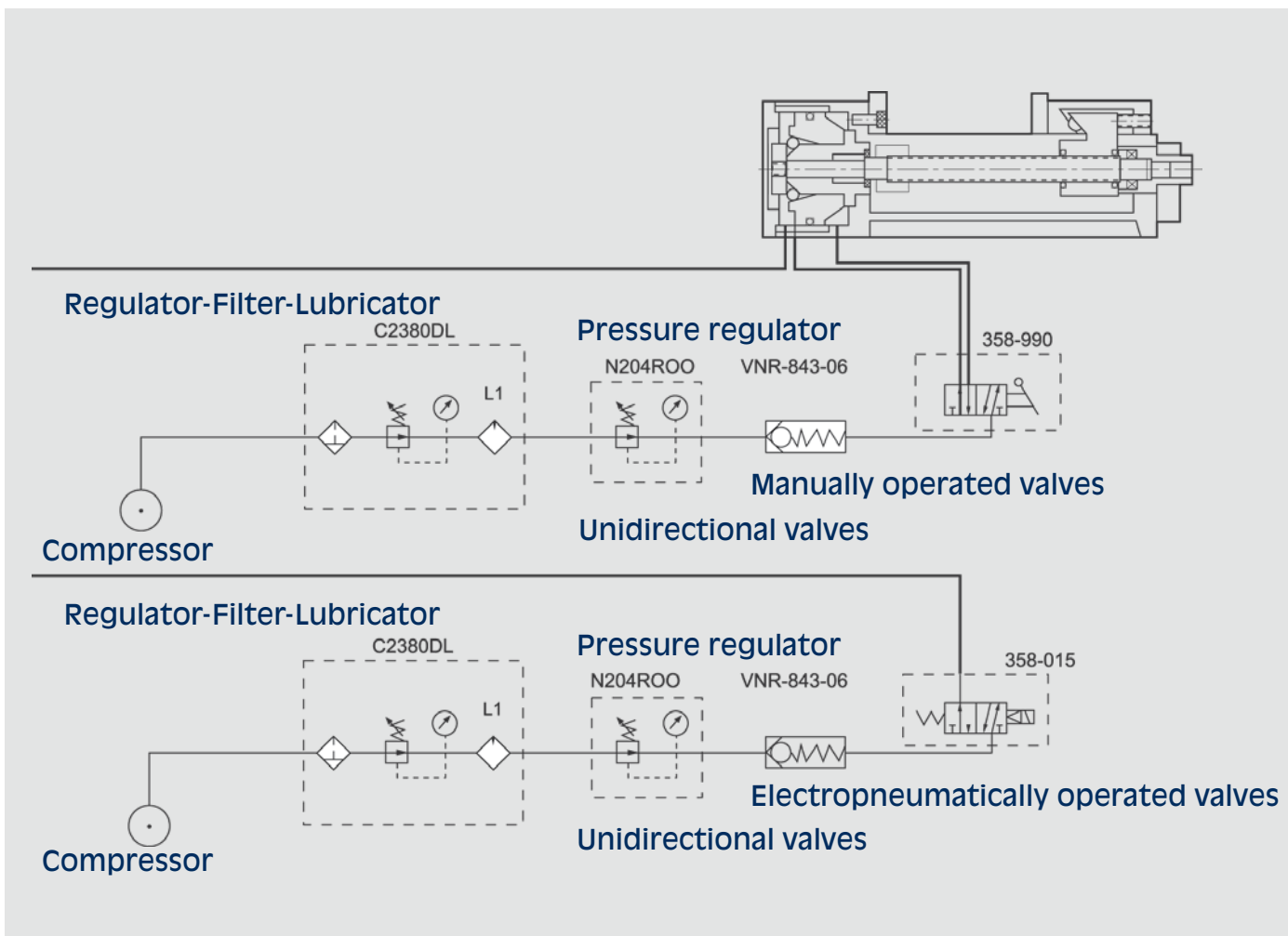

Id. no.	Type	Power kN	Air pressure bar	Stroke mm	Net weight kg	Weight kg
77 58 91 21	SV 130	16	1,5 - 7	0 - 3	40	42
77 58 92 21	SV 160	21	1,5 - 7	0 - 4	52	55

Tolerances

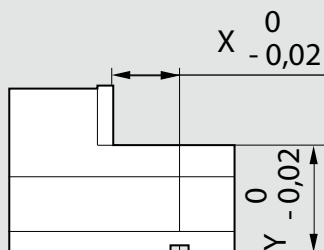

Pair of smooth jaws (HRC 55°-58°)

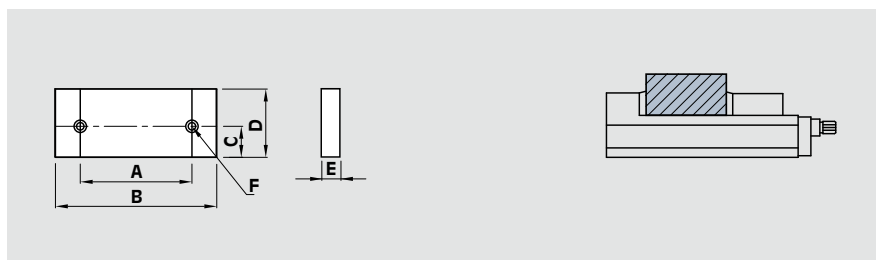

Id. No.	For type	A mm	B mm	C mm	D mm	E mm	F mm
58 91 41 19	SV 130	90	130	25	55	15	M10x20L
58 92 41 19	SV 160	90	160	25	58	15	M10x20L

Pair of grooved jaws (HRC 55°-58°)

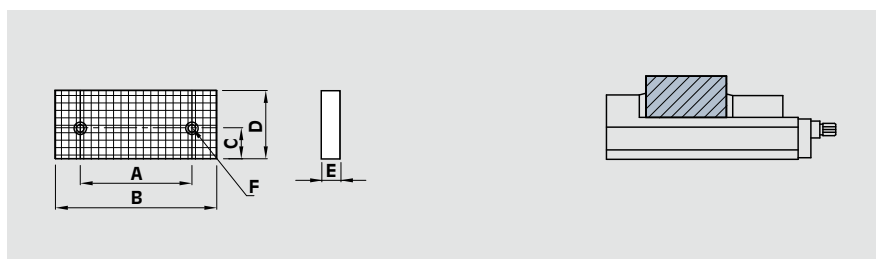
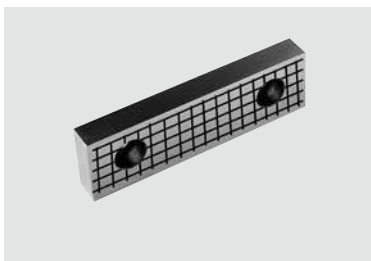

Id. No.	For type	A mm	B mm	C mm	D mm	E mm	F mm
58 91 42 19	SV 130	90	130	25	55	15	M10x20L
58 92 42 19	SV 160	90	160	25	58	15	M10x20L

Pair of V jaws (HRC 55°-58°)

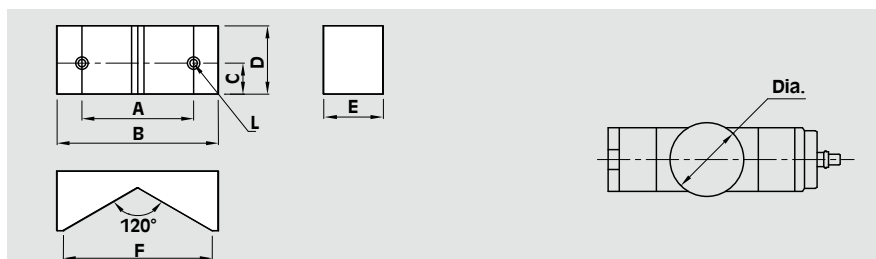

Id. No.	For type	A mm	B mm	C mm	D mm	E mm	F mm	L mm	dia. mm
58 91 44 19	SV 130	90	130	25	55	48	120	M10x16L	100-230
58 92 44 19	SV 160	90	160	25	58	48	120	M10x16L	100-230

Pair of positioning keys

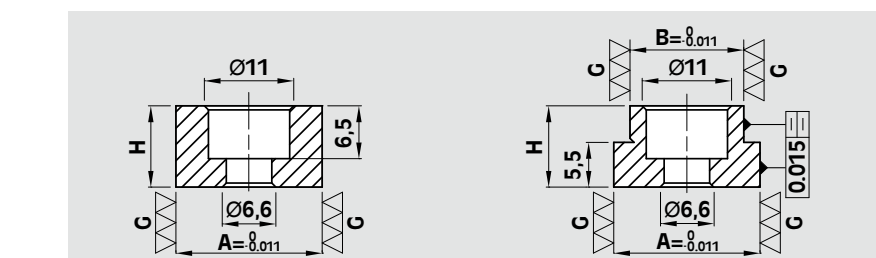

Id. No.	For type	A mm	B mm	H mm	
58 90 13 92	SV 130	18	12	10	25
58 90 13 93		18	14	10	25
58 90 13 94		18	16	10	25
58 90 13 96		18	20	10	25
58 90 13 97	SV 160	18	22	10	25
58 90 13 95		18	18	10	22

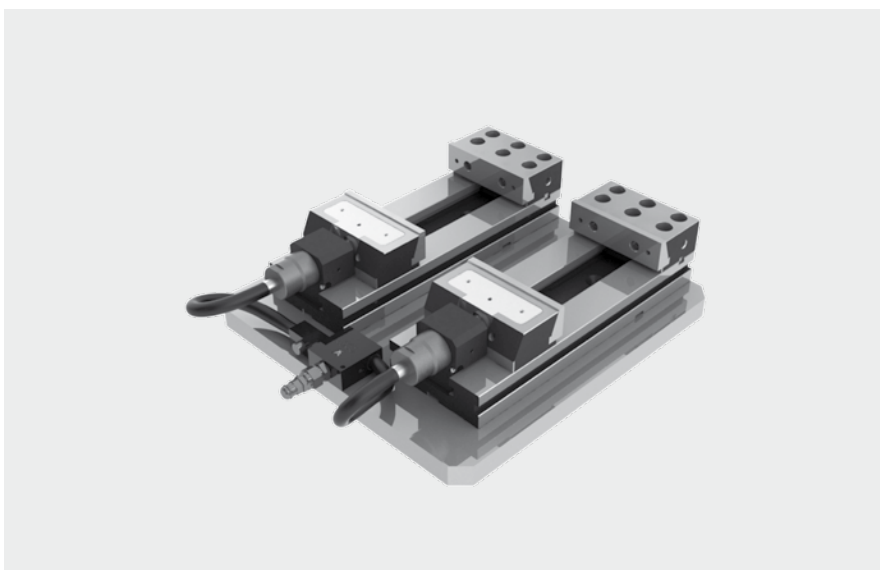

SET TC HYDRO - DUO

Modular clamping equipment with hydraulic clamping unit with:
SUBPLATE
2 TC VISES
SEQUENCE VALVES
CONNECTING PIPES and MANIFOLD

Id. No.	Type
33 58 02 27	TC H DUO 150x200
33 58 02 28	TC H DUO 150x250
33 58 02 29	TC H DUO 150x300

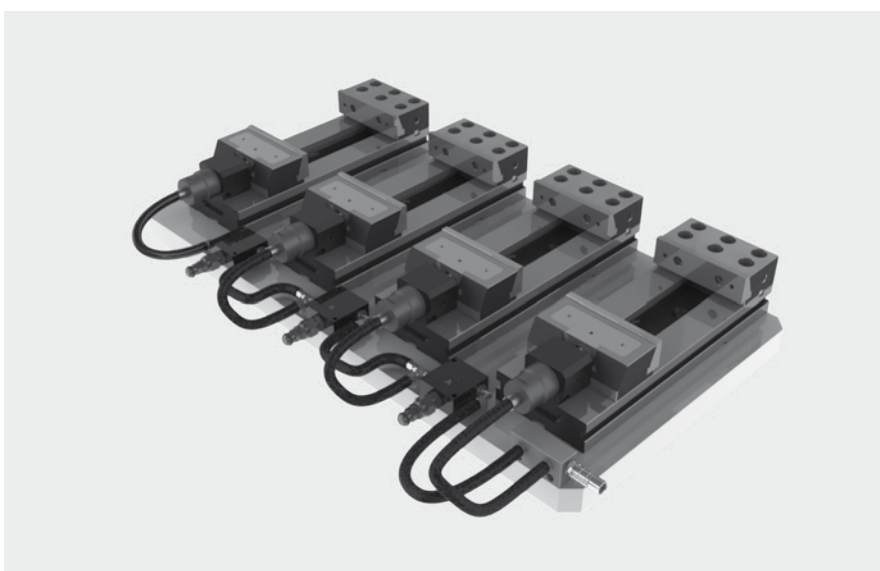

SET TC HYDRO - TETRA

Modular clamping equipment with hydraulic clamping unit with:
SUBPLATE
4 TC VISES
SEQUENCE VALVES
CONNECTING PIPES and MANIFOLD

Id. No.	Type
33 58 02 47	TC H TETRA 150x200
33 58 02 48	TC H TETRA 150x250
33 58 02 49	TC H TETRA 150x300

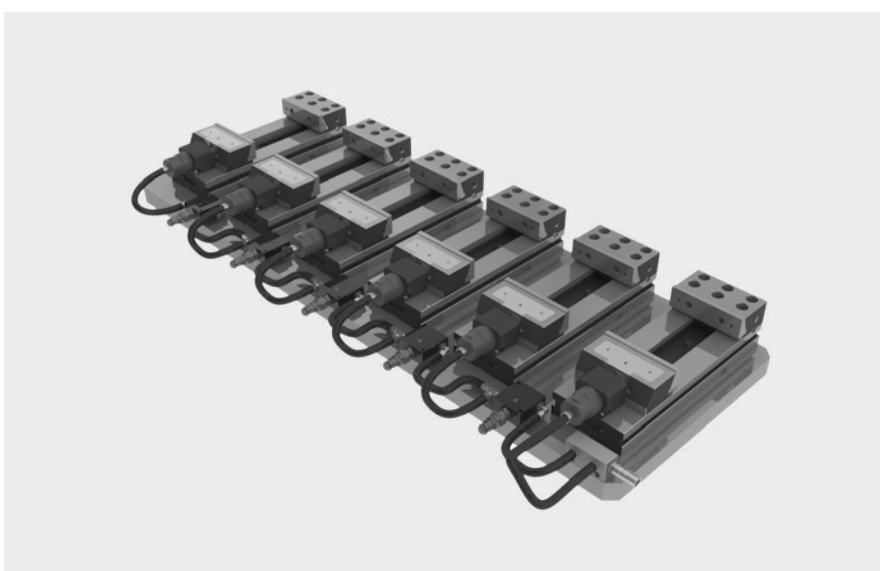

SET TC HYDRO - ESA

Modular clamping equipment with hydraulic clamping unit with:
SUBPLATE
6 TC VISES
SEQUENCE VALVES
CONNECTING PIPES and MANIFOLD

Id. No.	Type
33 58 02 67	TC H ESA 150x200
33 58 02 68	TC H ESA 150x250
33 58 02 69	TC H ESA 150x300

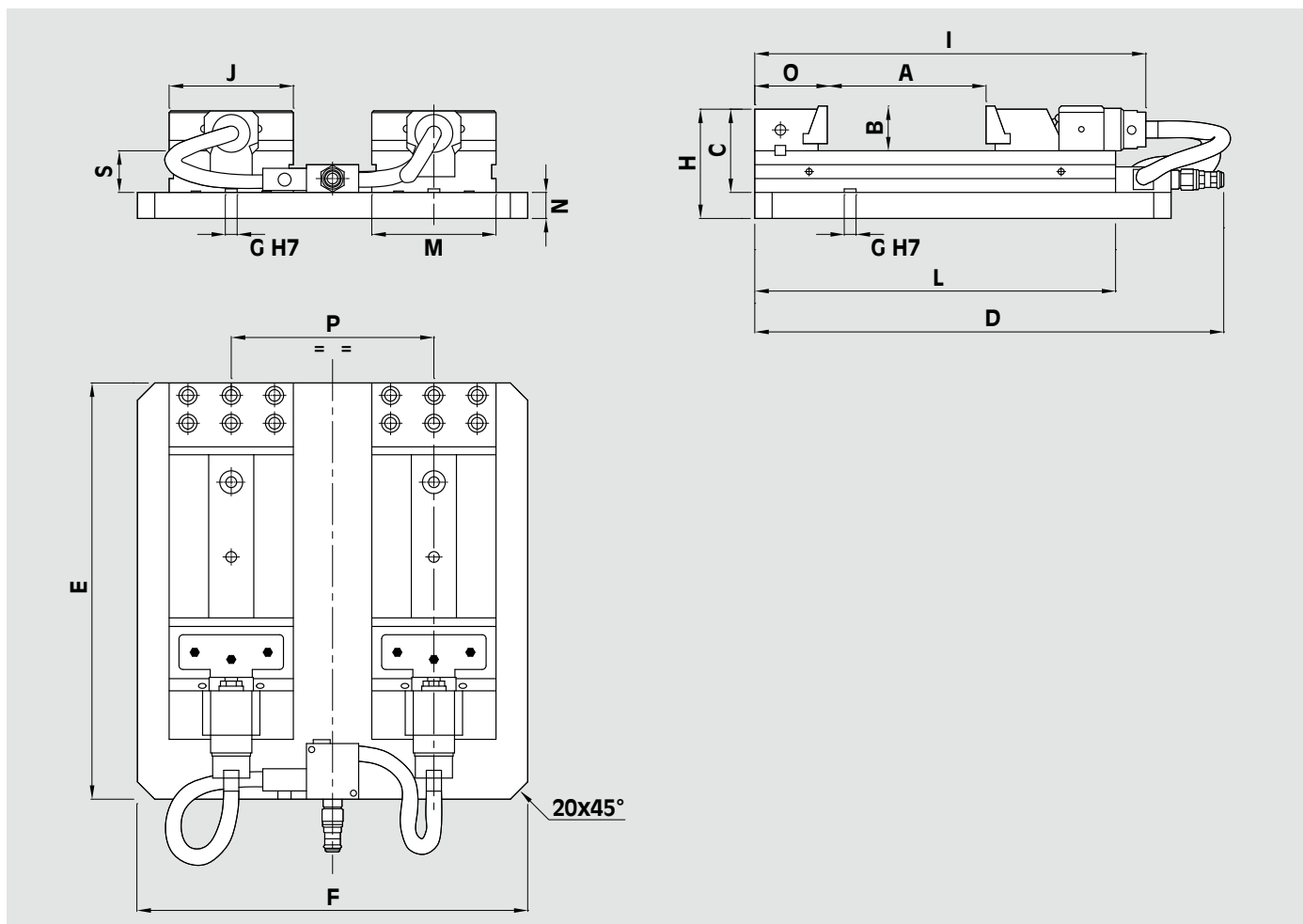

Id. No.	Type	A mm	B mm	C mm	D mm	E mm	F mm	G mm	H mm	I mm	J mm	L mm	M mm	N mm	O mm	P mm	S mm	Weight kg
33 58 02 27	TC H DUO 150x200	200	50	98	550	480	450	18	128	481	150	413	150	30	85	230	48	108
33 58 02 28	TC H DUO 150x250	250	50	98	600	530	450	18	128	531	150	463	150	30	85	230	48	118
33 58 02 29	TC H DUO 150x300	300	50	98	650	580	450	18	128	588	150	520	150	30	85	230	48	128
33 58 02 47	TC H TETRA 150x200	200	50	98	550	480	900	18	138	481	150	413	150	40	85	230	48	249
33 58 02 48	TC H TETRA 150x250	250	50	98	600	530	900	18	138	531	150	463	150	40	85	230	48	271
33 58 02 49	TC H TETRA 150x300	300	50	98	650	580	900	18	138	588	150	520	150	40	85	230	48	295
33 58 02 67	TC H ESA 150x200	200	50	98	550	480	1370	18	138	481	150	413	150	40	85	230	48	378
33 58 02 68	TC H ESA 150x250	250	50	98	600	530	1370	18	138	531	150	463	150	40	85	230	48	411
33 58 02 69	TC H ESA 150x300	300	50	98	650	580	1370	18	138	588	150	520	150	40	85	230	48	448



Air/oil foot pump

Id. No.

71 66 03 05



Air/oil manual pump

Id. No.

71 66 03 15



Pressure - gauge

Id. No.

51 43 12 51

Working example

