

FAST CLAMPS

14



FAST CLAMPS

Page 14.4



Work locators

Page 14.36



Risers + V blocks

Accessories

Page 14.40



Centering pin

Page 14.47



Side Clamps

Page 14.48

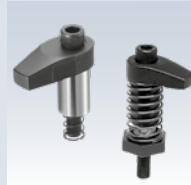

Hook Clamps

Page 14.65



Adjustable stops

Page 14.69

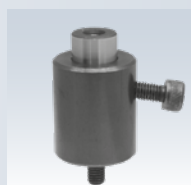

Work supports

Page 14.72



Remote control units

Page 14.80



Contact bolts

Page 14.81



Clamp screws

Page 14.83

Fast Clamps

Speedier In Setup
Than Conventional
Manual Clamping

No tools needed

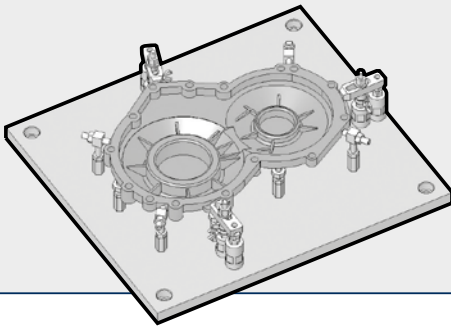

More Economical
Than Hydraulic
Clamping

Much lower fixture costs
Maintenance free

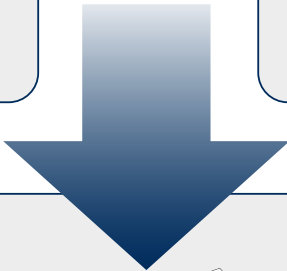
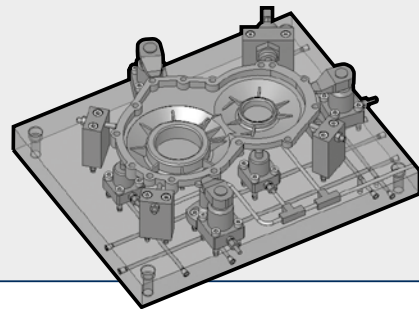

Positive Clamping
Spiral cam mechanism

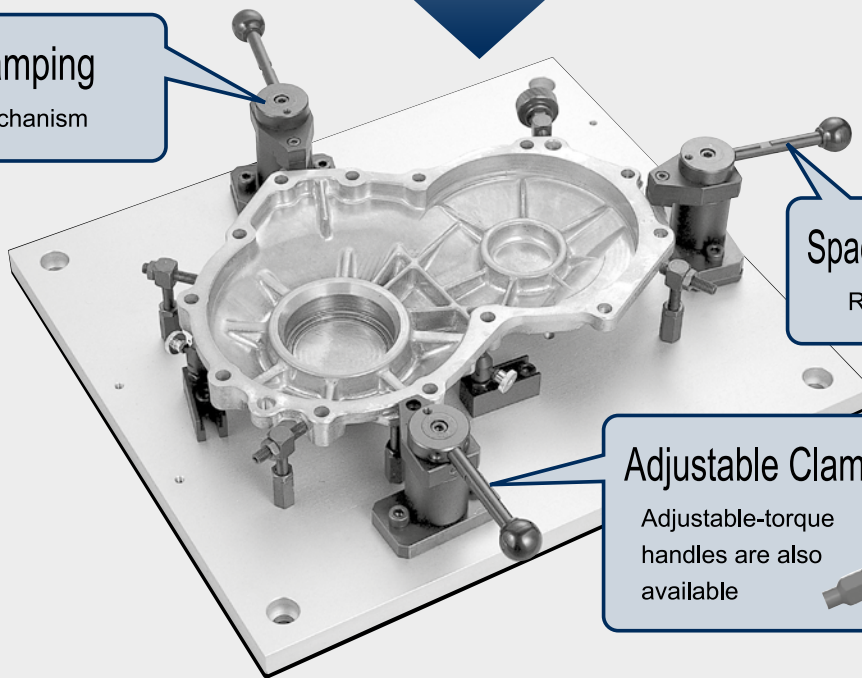

Space-Saving Design
Removable handle

Adjustable Clamping Force
Adjustable-torque
handles are also
available

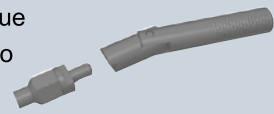

Fast Clamps serve for varied applications in machining
and assembly jobs in different industries.

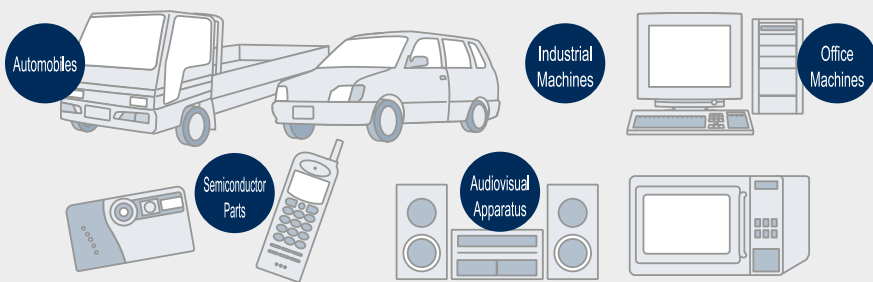

Added Product Items Offer A Wider Range Of Applications

Stronger Clamping Force
Clamping-Height Adjustment
Greater Performance

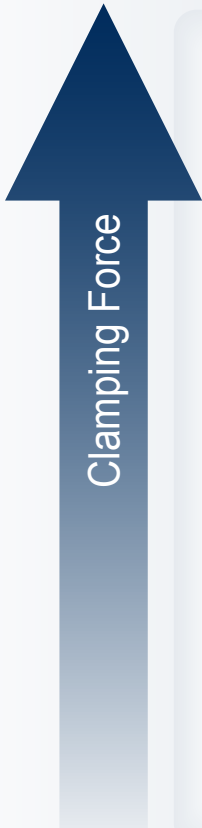

NEW

Pull Clamps Heavy

Clamping Range: up to 2.5mm
Clamping Force: up to 8,000N

Swing Clamps Heavy

Clamping Range: up to 1.6mm
Clamping Force: up to 6,000N

NEW

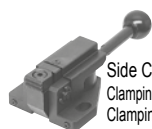

Side Clamps, Standard
Clamping Range: 2mm
Clamping Force: up to 4,000N



Push Clamps, Standard
Clamping Range: up to 2.5mm
Clamping Force: up to 4,000N



Pull Clamps, Standard
Clamping Range: up to 2mm
Clamping Force: up to 2,500N



Swing Clamps, Standard
Clamping Range: up to 1.8mm
Clamping Force: up to 1,200N

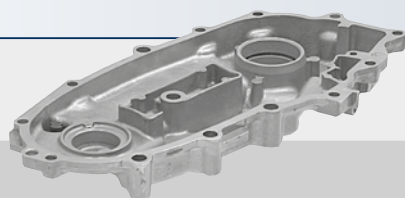

Die-Cast Parts

This extended line of Fast Clamps allows clamping parts made from materials ranging from non-ferrous metals like aluminum, zinc, etc. to cast iron and steel.

Setting a clamping force is important when clamping a part that can easily get strained.

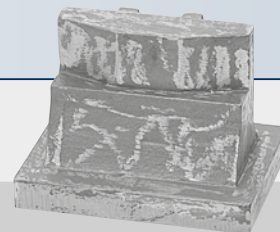

Cast-Iron Parts

To compensate for variations between castings, a long clamping height range is needed. Clamping force is also an important factor for castings that receive a comparatively heavy load when being machined.



With Handle

Without Handle

Note) Clamping Pins or Screws must be ordered separately.

Body & CAM	
Material	SCM440 steel
Finish	Black oxide
Heat Treat	Quenced and tempered
Handle	
Material	S45C steel
Finish	Black oxide
Ball Knob	
Material	ABS resin
Color	Black

How To Use

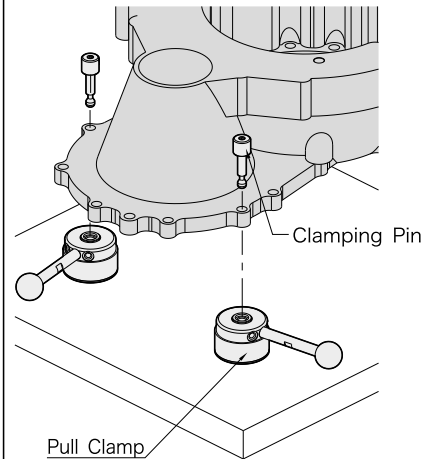

How To Locate Workpiece

1. Basic Method

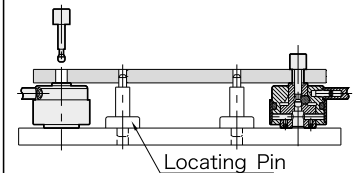

2. Method for clamping and locating a workpiece at a time

Give an accuracy shown below to the hole spacing to generate a locating accuracy of ± 0.08 .

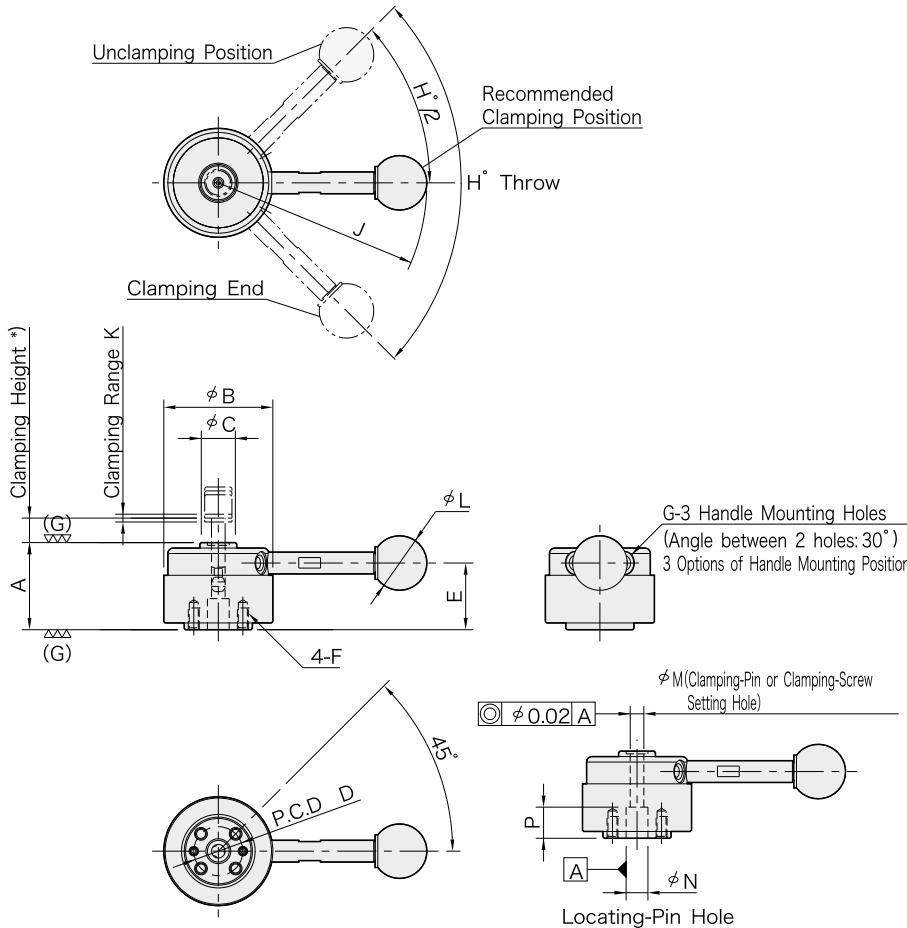
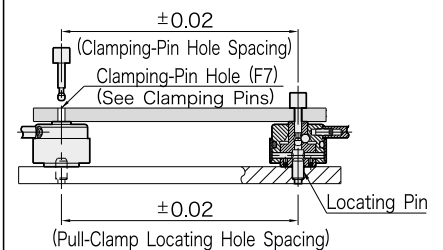

Technical Infomation

Allowable Loads in Machining of Workpiece Bottom
Ensure that a force more than indicated below is not applied to the workpiece bottom.

Series	Allowable Force To Workpiece Bottom (Per Clamp)
QLPD150	max.2000N
QLPD200	max.5500N

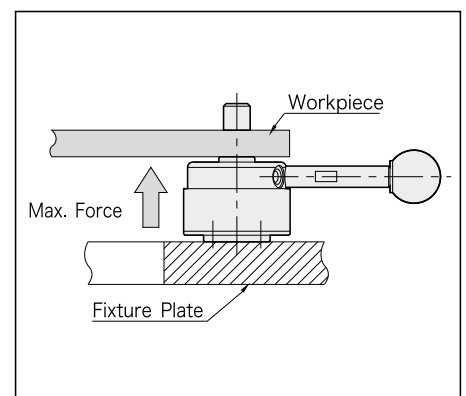

Series	A (± 0.01)	B	C	D (P.C.D)	E	F	G	H	K	M (F7)
QLPD150	32	40	13.5	18	24.5	M4x0.7 8 deep	M5x0.8	90°	1.5	5
QLPD200	40	50	18	25	30.7	M6x1 9 deep	M6x1	110°	2	8

Series	N (G6)	P	Clamping Force (N)	Clamping Mechanism	Recommended Workpiece Thickness Tolerance **)
QLPD150	8	10	900	Spiral Cam Cam Angle:4°	± 0.3
QLPD200	12	13	2500		± 0.5

With Handle

Part Number	J	L	Allowable Operating Load (N) ***)	Weight (g)
51991101	76.5	20	150	245
51991102	111.5	25	200	470

Without Handle

Part Number	Weight (g)
51991103	220
51991104	420

*) Grip length of Clamping Pin(workpiece thickness)

**) Maintaining these recommended tolerances allows minimizing the variation of handle position in the clamping mode in clamping with the use of the Clamping Pin.

***) Allowable load to operate the handle.

QLPD-X

CLAMPING PINS(Standard)



Shank	
Material	SCM435 steel
Finish	Precision ground
Heat	Treated (shank end)
Head	
Material	SCM45C steel
Finish	Black oxide
Heat Treat	Quenched and tempered

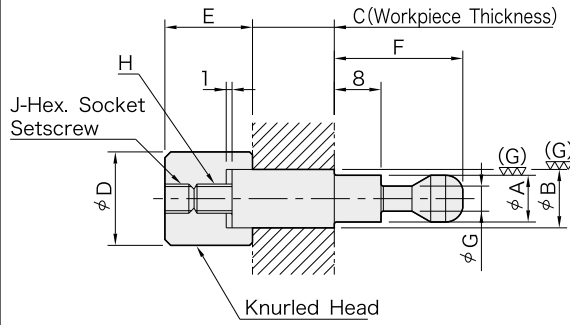

C dimension is adjustable by +/-1mm to fit actual workpiece thickness.

How To Use

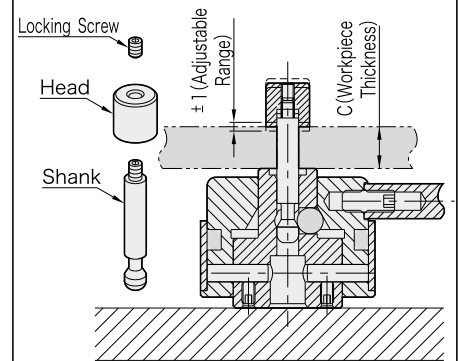

Ordering Example

QLPD150-5x5-10.5		
Shank Size	C Dim.	

· Custom Clamping Pins(different B dimensions) are available on request.

Part Number	A (f7)	B (f7)	C *) (By 0.1 mm)	D	E	F	G	H	J	Pull Clamps	Weight (g)
51991105 -(C Dim. in mm)	5	5	3 ≤ C ≤ 50	10	10	17	3	M3x0.5	M3x0.5-4L	QLPD150 Series	min. 8 to max.16
51991106 -(C Dim. in mm)		6									min. 8 to max.19
51991107 -(C Dim. in mm)	8	8	4 ≤ C ≤ 80	16	15	22	4.3	M5x0.8	M5x0.8-5L	QLPD200 Series	min.30 to max.60
51991108 -(C Dim. in mm)		10									min.31 to max.77

*) For ordering, specify workpiece thickness.

QLPD-M

CLAMPING SCREWS(Standard)



Material	SCM440 steel
Finish	Black oxide
Heat Treat	Quenched and tempered

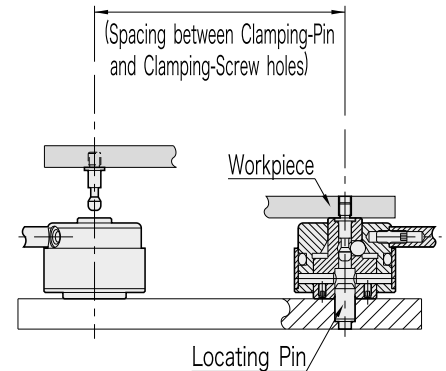
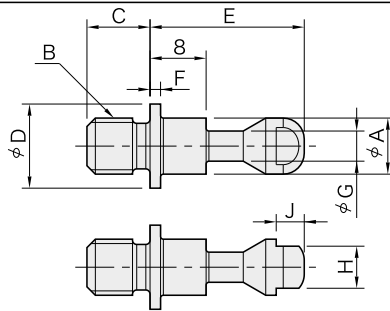

Part Number	A	B	C	D	E	F	G	H	J	Pull Clamps	Weight (g)
51991109	5	M 5x0.8	6	8	17	1.2	3	4	2.5	QLPD150 Series	3
51991110		M 6x1	7								4
51991111	8	M 8x1.25	9	12	22	1.5	4.3	6	4	QLPD200 Series	10
51991112		M10x1.5	11								13

Recommended Spacing Tolerance in Use of Clamping Screws

Custom Clamping Screws (different screw thread sizes) are available on request.

QLPDH

PULL CLAMPS (Heavy)

NEW



Body & Clamp ring	
Material	SCM440 steel
Finish	Black oxide
Heat Treat	Quenched and tempered
Handle Shank	
Material	S45C steel
Finish	Black oxide
Heat Treat	Quenched and tempered
Handle	
Material	Plastic
Color	Black

Note) Clamping Pins or Screws must be ordered separately.

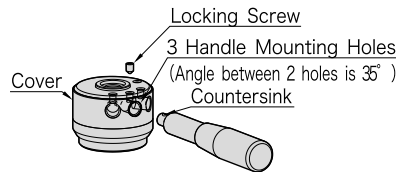
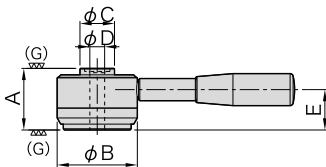
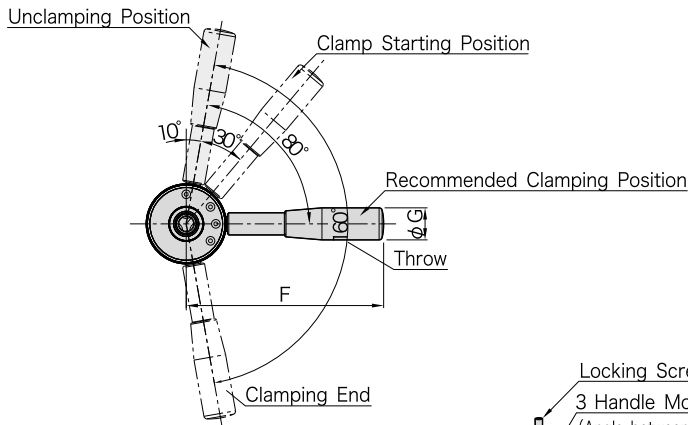

The handle can be removed by loosening the locking screw.
To keep the handle mounted permanently, make sure that the locking screw is fully tightened.
3 options of handle mounting position.

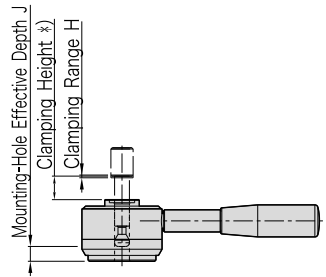
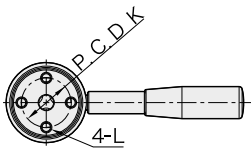

How To Use

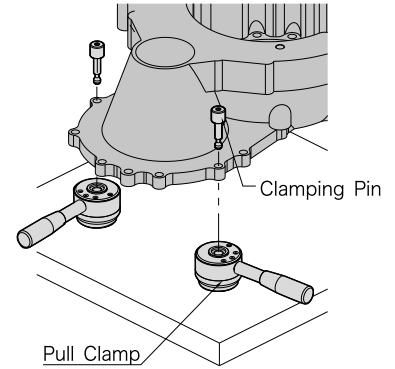

How To Locate Workpiece

1. Basic method

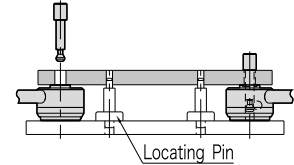

2. Method for clamping and locating a workpiece at a time.
Give an accuracy shown below to the hole spacing to generate a locating accuracy of ± 0.08 .

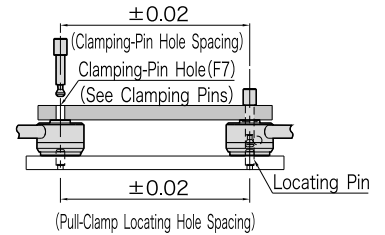

Technical Information

Allowable Loads in Machining of Workpiece Bottom

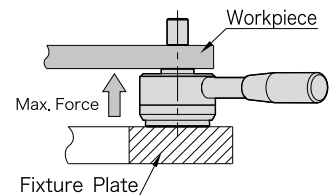

Part Number	Allowable Force To Workpiece Bottom (Per Clamp)
51991501	max. 8000N
51991502	max. 14000N

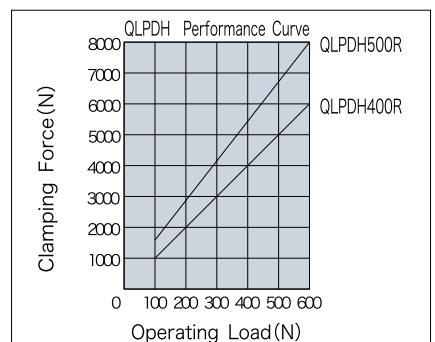

Part number	Series	A (± 0.01)	B	C	D (F7)	E	F	G	H	J	K (P, C, D)
51991501	QLPDH 400 R	50	65	28	12	36	160	26	2	10	40
51991502	QLPDH 500 R	63	80	34	16	45	180	28	2.5	12	50

Part number	Series	L	Allowable Operating Load (N) **)	Clamping Force (N)	Clamping Mechanism	Recommended Workpiece Thickness Tolerance ***)	Weight (kg)
51991501	QLPDH 400 R	M 8x1.25 14 deep	600	6,000	Spiral Cam	± 0.5	1.2
51991502	QLPDH 500 R	M10x1.5 18 deep		8,000	Cam Angle : 4°	± 0.8	2.2

*) Grip length of Clamping Pin (workpiece thickness)

***) Allowable load to operate the handle

***) Maintaining these recommended tolerances allows minimizing the variation of handle position in the clamping mode in clamping with the use of the Clamping Pin.

QLPDH-X

CLAMPING PINS (Heavy)

NEW

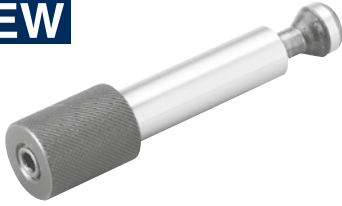

Shank	
Material	SCM435 steel
Finish	Precision ground
Head	
Material	S45C steel
Finish	Black oxide
Heat Treat	Quenched and tempered

C dimension is adjustable by ± 1 mm to fit actual workpiece thickness.

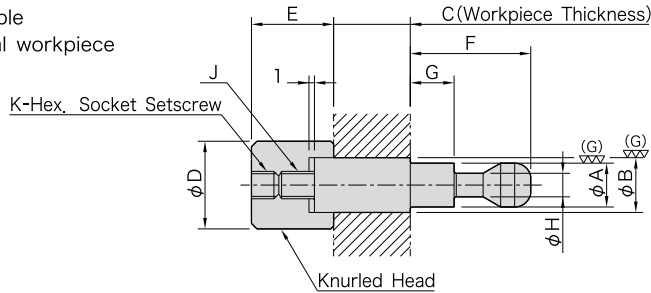

How To Use

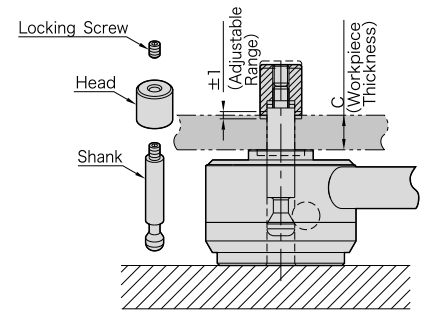

Ordering Example

QLPDH400-12-20.5

Part Number C Dim.

Custom Clamping Pins (different B dimensions) are available on request.

Part Number	A (f7)	B (f7)	C *) (By 0.1mm)	D	E	F	G	H	J	K	Pull Clamps	Weight (g)
51991503-(C Dim. In mm)	12	12	0 < C ≤ 100	18	23	38	21.5	6.5	M 8x1.25	M 8x1.25- 8L	QLPDH400R	70 to 160
51991504-(C Dim. In mm)		16	175 to 265									
51991505-(C Dim. In mm)	16	16	0 < C ≤ 120	24	29	48	28	9.5	M10x1.5	M10x1.5 -10L	QLPDH500R	160 to 350
51991506-(C Dim. In mm)		20	325 to 515									

*)For ordering, specify workpiece thickness.

QLPDH-M

CLAMPING SCREWS (Heavy)

NEW



Material	SCM 435
Finish	Black oxide
Heat Treat	Quenched and tempered

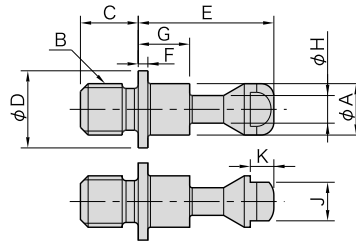

Recommended Spacing Tolerance in Use of Clamping Screws

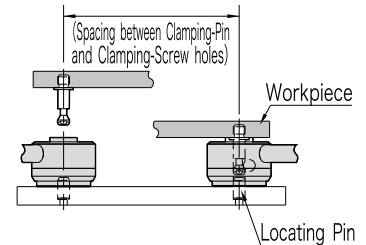

Custom Clamping Screws (different screw thread sizes) are available on request.

Part Number	A	B	C	D	E	F	G	H	J	K	Pull Clamps	Weight (g)
51991507	12	M12x1.75	13	20	38	2	21.5	6.5	10	4	QLPDH400R	40
51991508		M16x2	17	55								
51991509	16	M16x2	17	25	48	2.5	28	9.5	13	5	QLPDH500R	90
51991510		M20x2.5	21	110								

QLSW

SWING CLAMPS(Standard)



With Handle

Without Handle

Body & Shaft	
Material	SCM440 steel
Finish	Quenched and tempered
Clamp arm & Adaptor Head	
Material	S45C steel
Finish	Quenched and tempered
Handle	
Material	S45C steel
Finish	Black oxide
Ball Knob	
Material	ABS resin
Finish	Black

How To Use

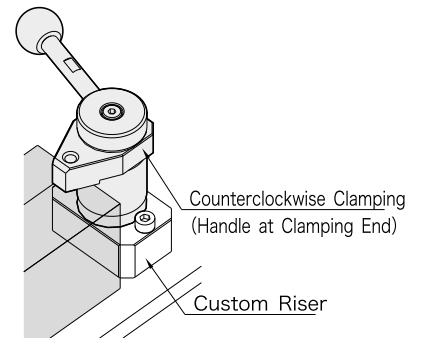
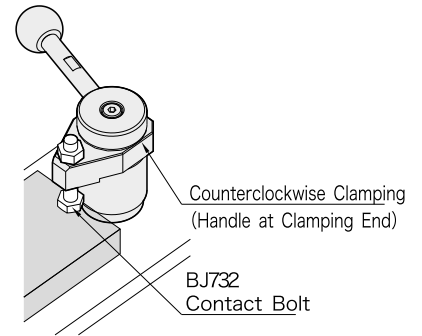

Counterclockwise Clamping

Clockwise Clamping

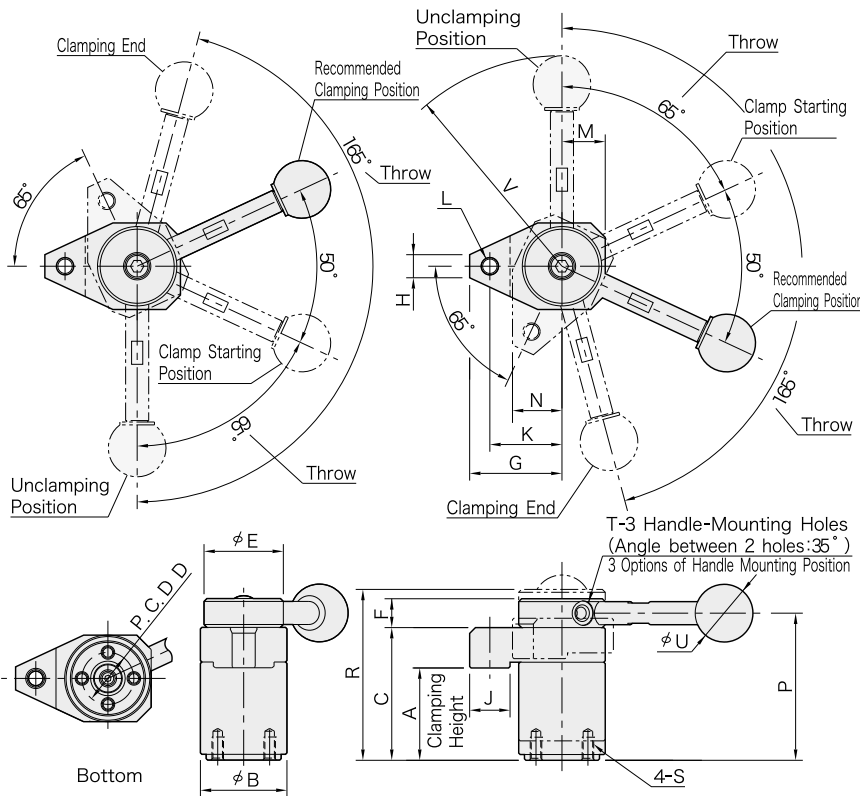

Size/Type	Clamping Direction	A	B	C	D (P, C, D)	E	F	G	H	J	K	L
QLSW150R	Clockwise	32	30	46	18	30	10	32	8	14	25	M6x1
QLSW150L	Counterclockwise	*)										
QLSW200R	Clockwise	45	40	63	25	38	13	40	12	16	32	M8x1.25
QLSW200L	Counterclockwise	**)										

*) Actual clamping height : 31.4 to 32.6 (clamping range :1.2)

**) Actual clamping height : 44.1 to 45.9 (clamping range :1.8)

Size/Type	M	N	P	R	S	T	Clamping Force(N)	Clamping Mechanism
QLSW150R	15	17	51	57.5	M4x0.7 8 deep	M5x0.8	800	Spiral Cam Cam Angle:4°
QLSW150L								
QLSW200R	20	22.5	69.5	78.1	M6x1 12 deep	M6x1	1200	
QLSW200L								

With Handle

Part Number	U	V	Allowable Operating Load (N) (***)	Weight (g)
51991115	20	73	150	320
51991117				
51991116	25	107	200	710
51991118				

Without Handle

Part Number	Weight (g)
51991119	295
51991121	
51991120	660
51991122	

***)) Allowable load to operate the handle

Note : The handle must be ordered separately.

Tip Installation

When installing a tip on the clamp arm, lock the clamp arm using a wrench to prevent the clamp from receiving any torque.

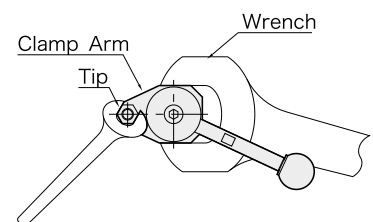

NEW

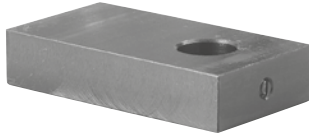

Material: S45C steel
Finish : Black oxide

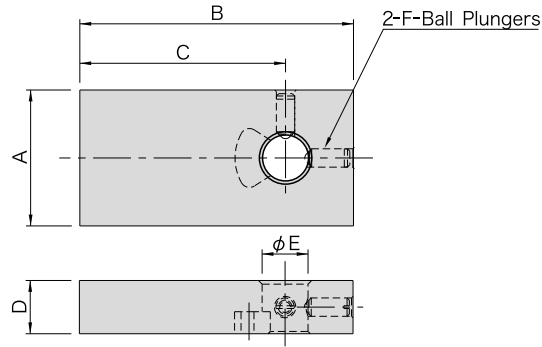

Technical Information

Allowable Loads in Machining of Workpiece Bottom

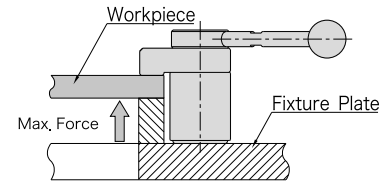

Series	Allowable Force To Workpiece Bottom (Per Clamp)
QLSW150	max.2100N
QLSW200	max.2700N

Clamp Arm Length Vs. Clamping Force Clamp Arm Length Vs. Strain During Clamping

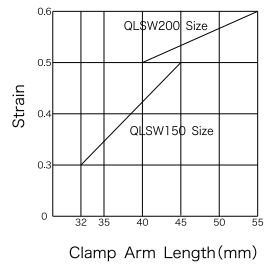
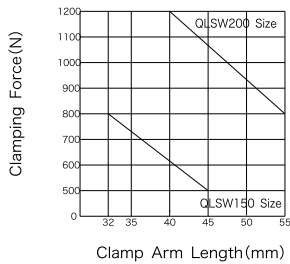

Notes :
 • Clamp arm length denotes C dimensions below.
 • Clamping force and strain during clamping denote values gained when the max. allowable load is applied to the handle.

How To Use

- Use for clamp arm customization
- Machine to your clamping requirements

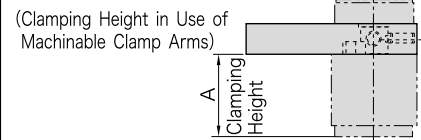

Part Number	A	B	C	D	E (F8)	F	Allowable Weight of Clamping Tip*) (g)	Swing Clamps	Weight (g)
51991513	30	60	45	12	10	M4	100	QLSW150Series	150
51991514	40	75	55	16	16	M5		QLSW200Series	330

Part Number	A
51991513	34**)
51991514	47***)

*) A clamping tip to mount on the end of the clamp arm must not weigh over 100g.

***) Actual clamping height:46.1 to 47.9 (clamping range:1.8)

***) Actual clamping height:33.4 to 34.6 (clamping range:1.2)

NEW



Body/Cam/Handle	
Material	SCM440 steel
Finish	Black oxide
Heat Treat	Quenched and tempered
Spindle	
Material	SCM435 steel
Finish	Black oxide
Heat Treat	Quenched and tempered
Arm/Covering/Handle	
Material	S45C steel
Finish	Black oxide
Heat Treat	Quenched and tempered
Adjustment knob	
Material	S45C steel
Finish	Black oxide
Handle	
Material	Plastic
Color	Black

How To Use

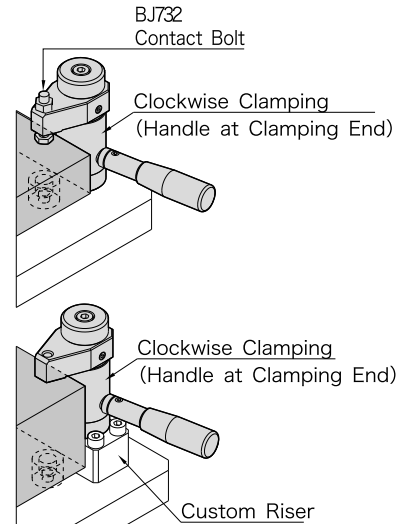

Counterclockwise Clamping

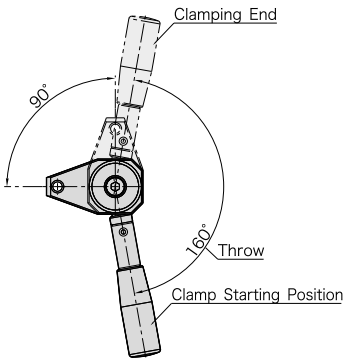

Clockwise Clamping

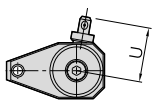
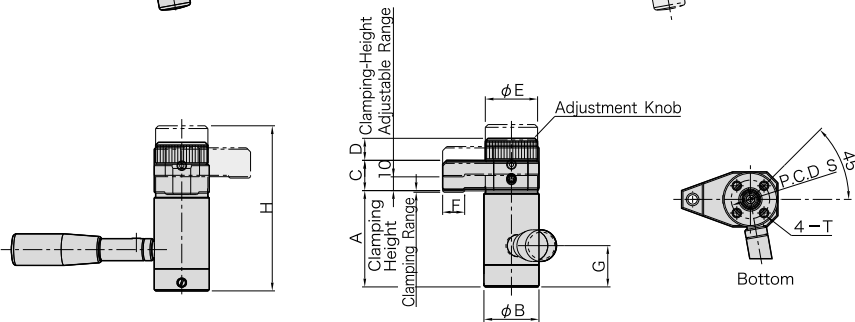
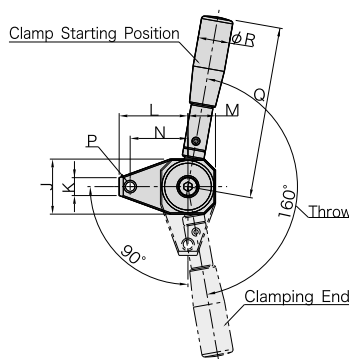

When Handle Is Removed

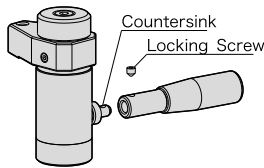

The handle can be removed by loosening the locking screw. To keep the handle mounted permanently, make sure that the locking screw is fully tightened. 3 options of handle mounting position.

Tip Installation

When installing a tip on the clamp arm, lock the clamp arm using a wrench to prevent the clamp from receiving any torque.

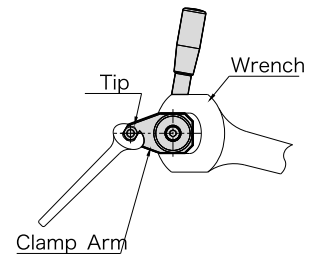

Technical Information

Allowable Loads in Machining of Workpiece Bottom

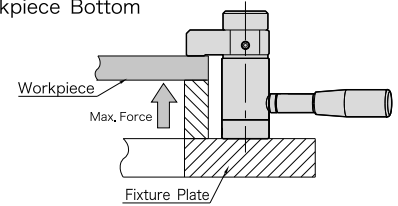

Series	Allowable Force To Workpiece Bottom (Per Clamp)
QLSWH400	max. 8000N
QLSWH500	max.14000N

Part Number	Clamping Direction	Clamping Range	Clamping Height	B	C	D	E	F	G	H	J	K	L	M
51991515	Clockwise	1.2	70 to 80	40	22	16	38	16	30	120	40	13	50	20
51991516	Counterclockwise													
51991517	Clockwise	1.6	80 to 90	50	25	20	48	24	38	137	50	18	60	25
51991518	Counterclockwise													

Part Number	N	P	Q	R	S (P,C,D)	T	U	Allowable Operating Load (N)*	Clamping Force (N)	Clamping Mechanism	Weight (kg)
51991515	42	M 8x1.25	125	23	28	M6x1 12 deep	39	600	3.500	Spiral Cam Cam Angle 2°	1.1
51991516											
51991517											
51991518											

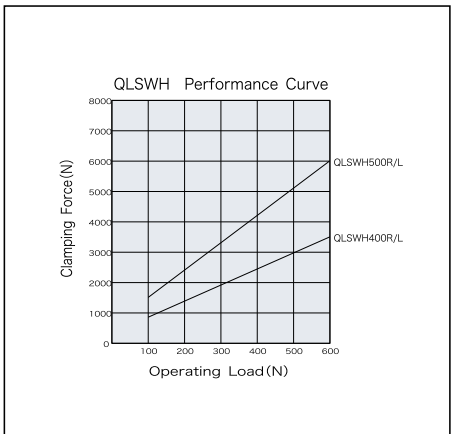

*) Allowable load to operate the handle

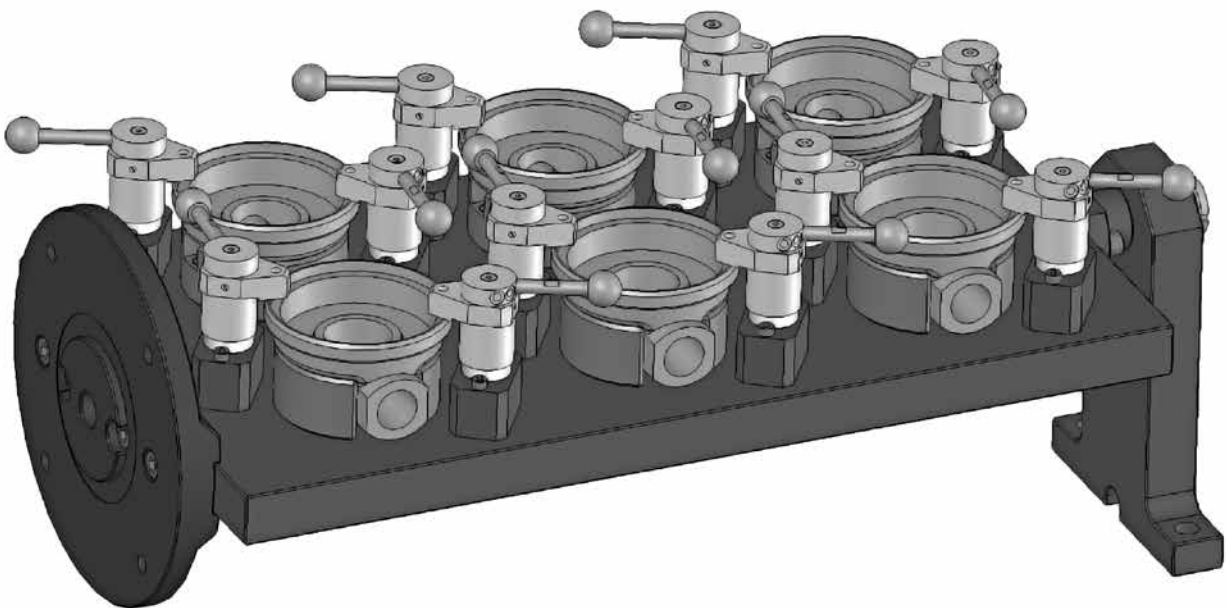
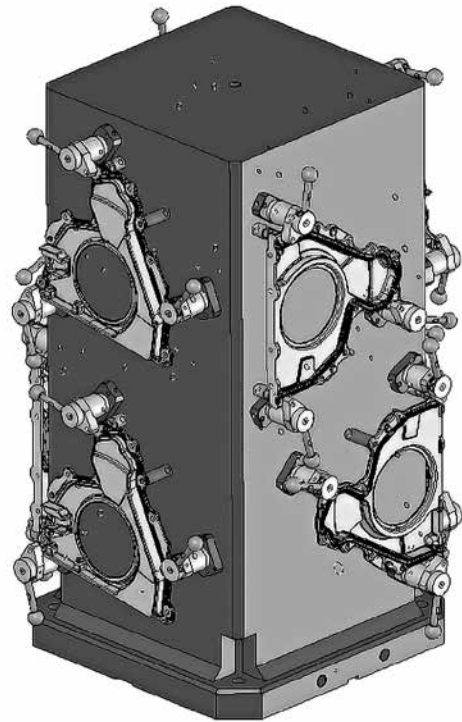
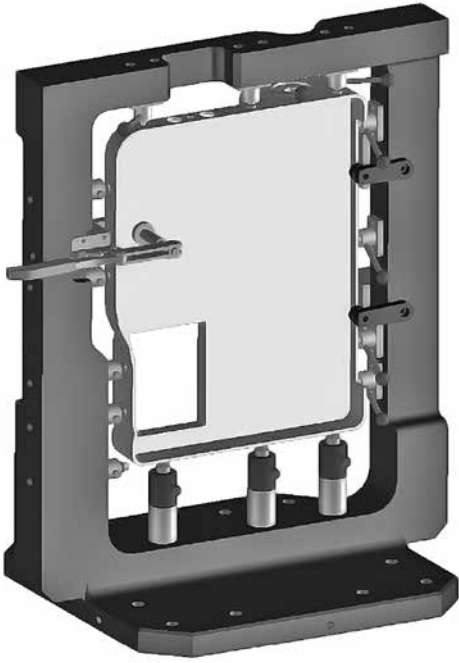

Information on Your Making Custom Clamp Arms for Standard Size of Swing Clamps

Recommended Dimensions

Series	A (F8)	B	E	F	G	H	J	K	L (Max.)*	M	N
QLSW150	10	12	5	32	M4x0.7	11	1.5	30	45	15	C5
QLSW200	16	16	6	42	M5x0.8	15	2	40	55	20	C8

*) See page 138 clamping force vs. clamp-arm length

Clamp Arm Installation/Removal Instructions

To install a clamp arm,

1. Fit it onto the shaft getting the stop pin received in the stop-pin slot provided on the clamp-arm bottom.
2. Place the adaptor head onto the shaft getting the shaft fitted into the shaft-receiving pocket in the adaptor head, and then lock the adaptor head using a hex. socket head cap screw.
3. Tighten the ball plungers inside the clamp arm.

To remove the clamp arm, follow the above steps back.

How To Determine D Dimensions

Series	C	D
QLSW150	46	46 - Clamping Height
QLSW200	63	63 - Clamping Height

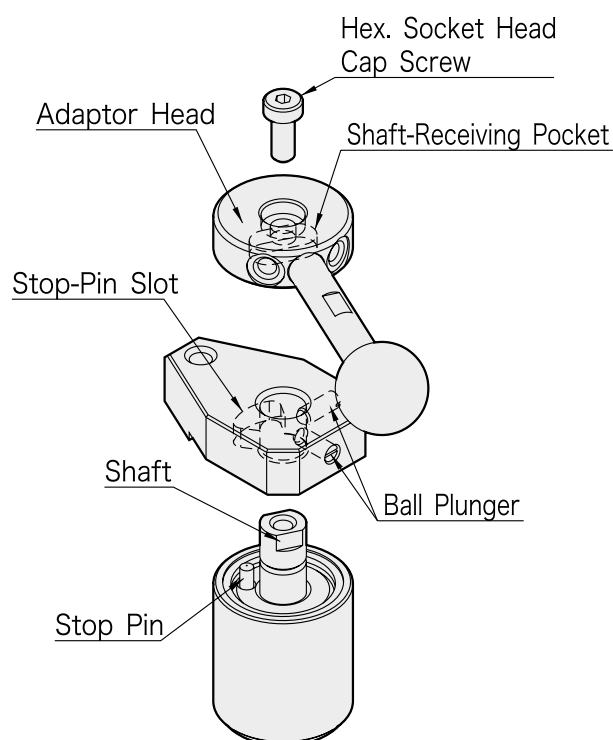
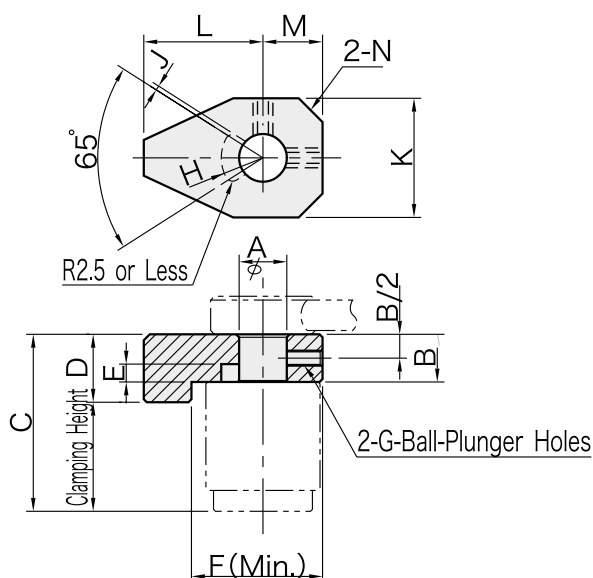

Clamp Arm Customization Examples

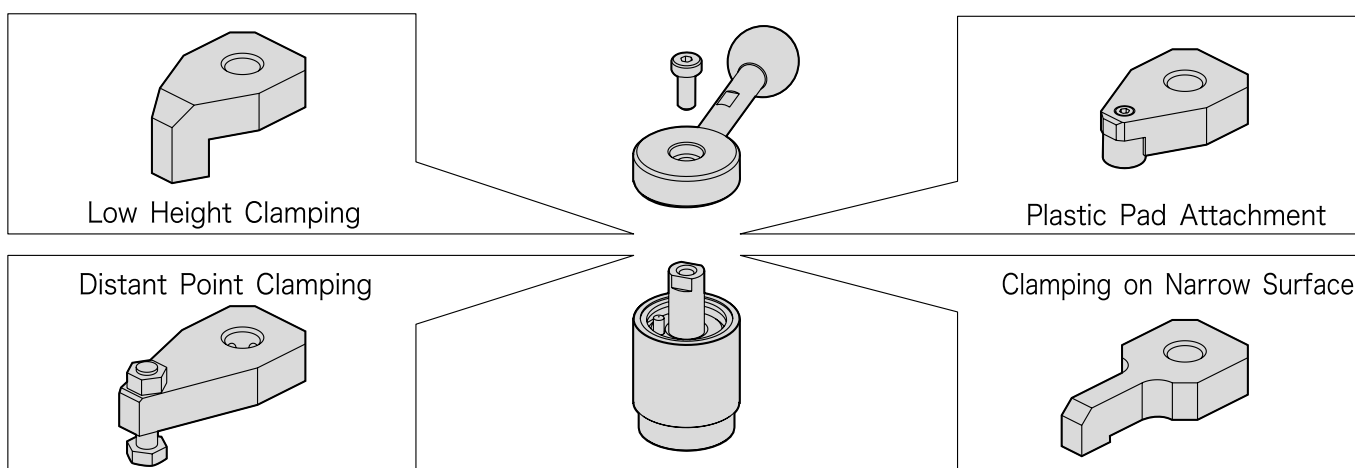

Information on Your Making Custom Clamp Arms for Heavy Size of Swing Clamps

Recommended Dimensions

Series	A (F8)	B	C	D	E ($\pm 0,1$)	F	G	H	L (Max.)
QLSWH400	32	15	21	13	5	M6x1	20	40	50
QLSWH500	41	19	24	15	6	M8x1.25	25	50	60

Clamp Arm Installation/Removal Instructions

To install a clamp arm,

1. Place the wave washer on the shoulder of the bolt and then fit the clamp arm onto the bolt.
2. Place the adjustment knob onto the bolt getting the bolt fitted into the bolt-receiving pocket in the adjustment knob, and then lock the adjustment knob using a hex. socket head cap screw.
3. Align the countersinks on the side of the holder with the setscrew holes on the side of the clamp arm, and then lock them using the hex. socket setscrews.

To remove the clamp arm, follow the above steps back.

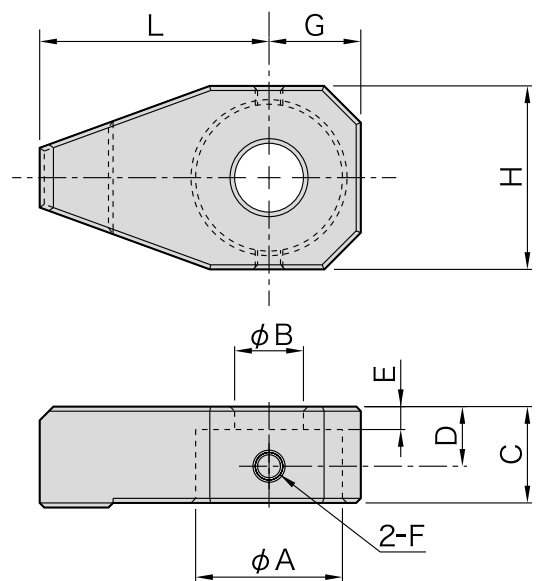
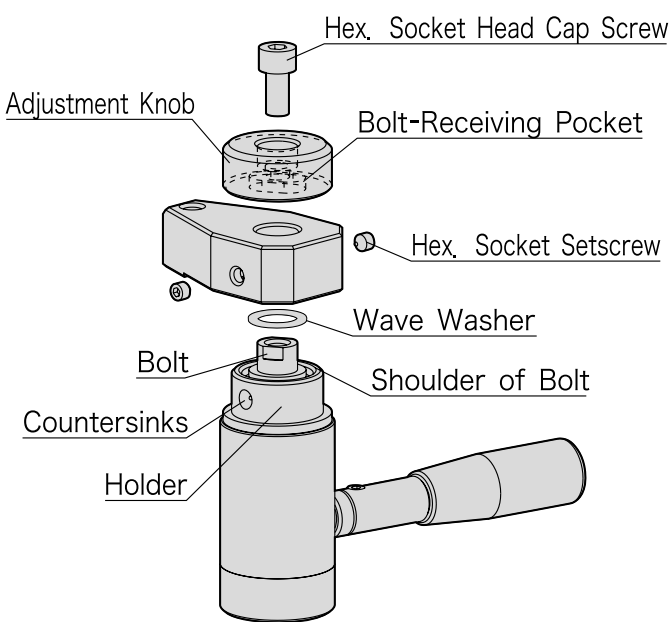

Clamp Arm Customization Examples

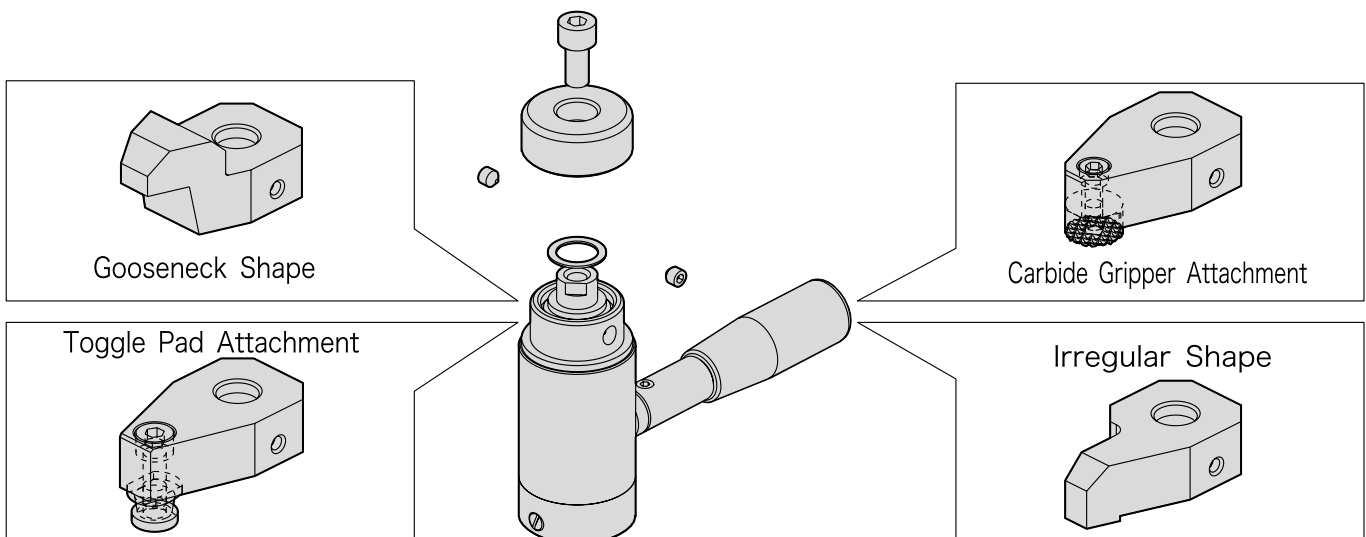



Body / Handle / Spindle	
Material	S45C steel
Finish	Black oxide
Heat treat	Quenched and tempered
Arm / Cam Shaft	
Material	SCM440 steel
Finish	Black oxide
Heat treat	Quenched and tempered
Knob	
Material	Phenolic plastic
Color	Black

How To Operate

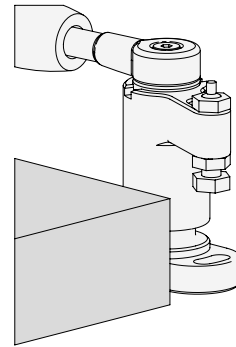

1. Unclamped
Load a workpiece.

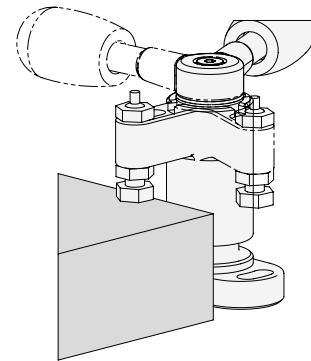

2. Arm Swing
Turn the handle to set the arm in position.

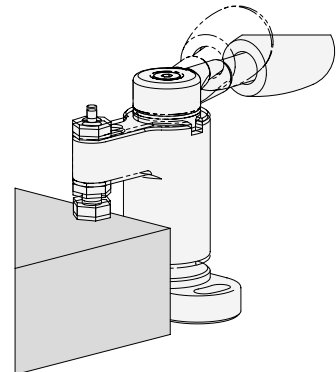

3. Clamping Setup
Continue turning the handle to set the spindle close to the workpiece.

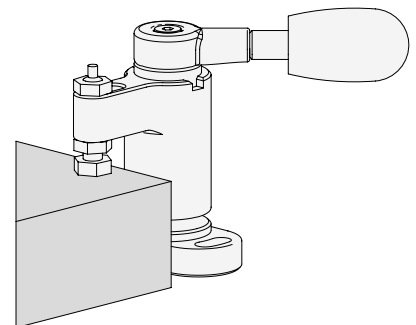

4. Clamping
Turn the handle to the recommended clamping position.

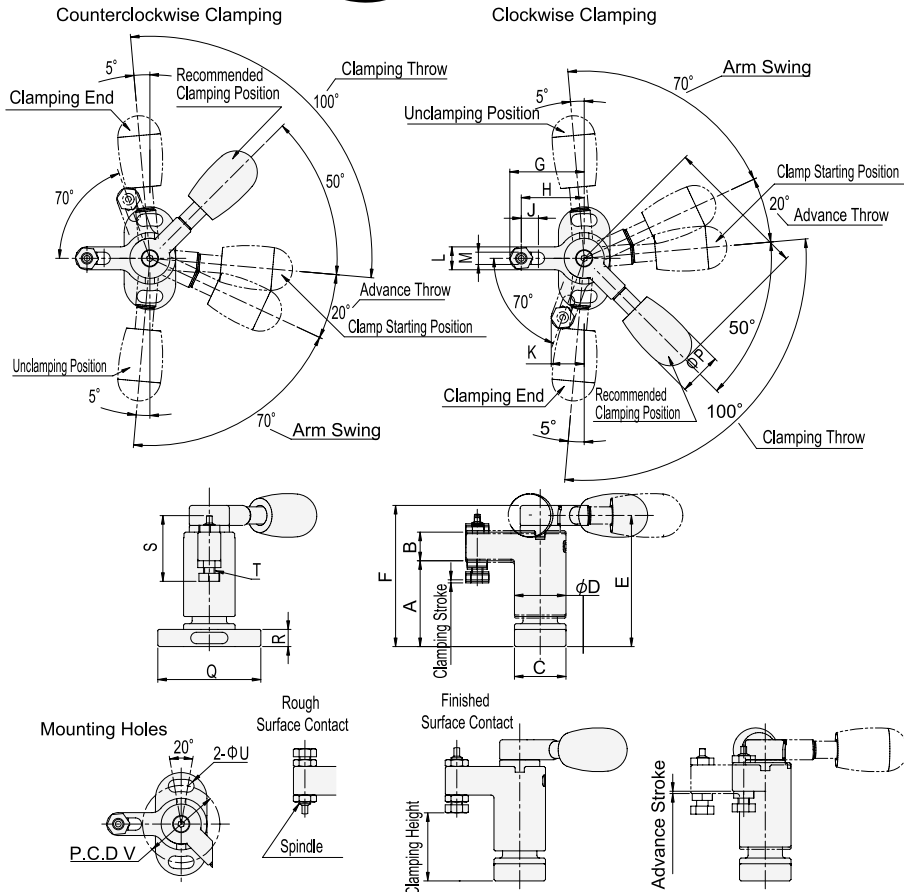

Part Number	Clamping Direction	Clamping Height *				Clamping Stroke	Advance Stroke
		Finished Surface Contact		Rough Surface Contact			
		Min.	Max.	Min.	Max.		
51991822	Clockwise	22.8	24.8	22.4	24.4	1	0.8
51991823	Counterclockwise	(22.3-23.3)	(24.3-25.3)	(21.9-22.9)	(23.9-24.9)		
51991824	Clockwise	31.3	33.3	32.2	33.3	1.4	1.1
51991825	Counterclockwise	(30.6-32)	(32.6-34)	(31.5-32.9)	(33.5-34.9)		

*) Clamping height can be adjusted. The parenthesised values denote actual clamping height.

Part Number	A	B	C	D	E	F	G	H	J	K	L	M	N	P	Q
51991822	30	10	18	18	45.8	49	26	22	6	11.5	8	4.3	50	15	36
51991823															
51991824	40	14	23	23	61.3	66	35	30	8	15.3	10	5.3	63	20	45
51991825															

Part Number	R	S	T	U	V	W	Allowable Operating Load (N) **	Clamping Force (N)	Clamping Mechanism	Weight (g)
51991822	6	22.8	M4×0.7	4.3	27	8	100	1,100	Spiral Cam Cam Angle:5°	112
51991823										
51991824										
51991825	8	28.5	M5×0.8	5.3	34	10	150	1,800		250

**) Allowable load to operate the handle

Performance Curve

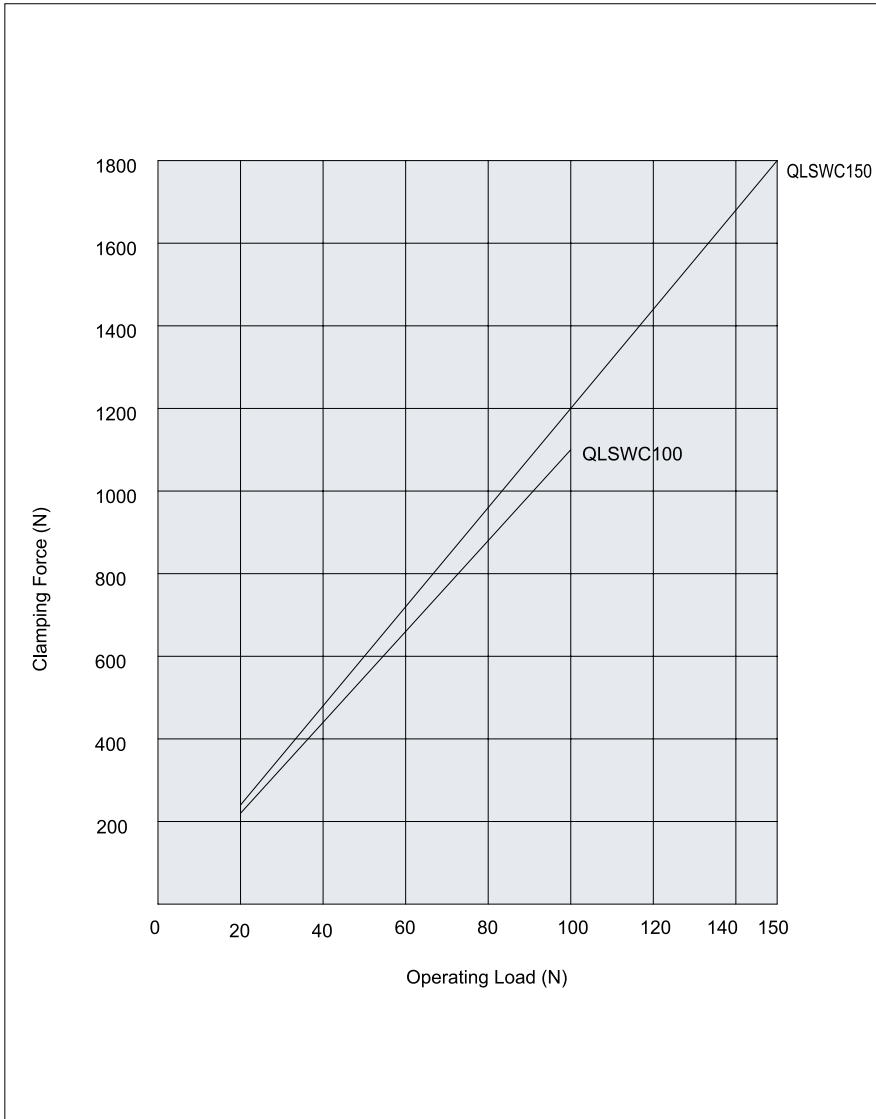

Technical Information

Allowable Loads in Machining of Workpiece Bottom

Ensure that any force more than stated below is not applied.

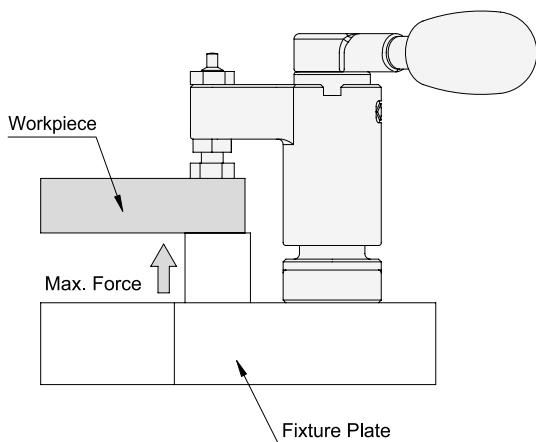

Series	Allowable Force to Workpiece Bottom (per Clamp)
QLSWC100	max.2,300N
QLSWC150	max.3,600N

How To Operate

How To Change Handle Position

The dodecagonal socket in the hub of the handle allows changing the handle operating angle by 30°.

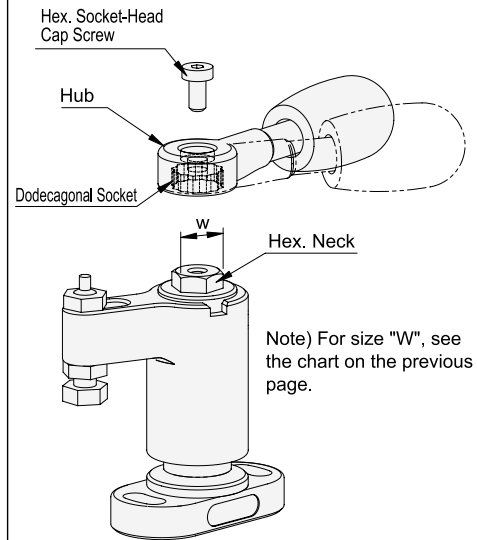

How To Release Locked Handle

When turned beyond the clamping end, the handle will be locked with a click. The locked handle can be released by following the instructions below.

When the spindle is not installed,

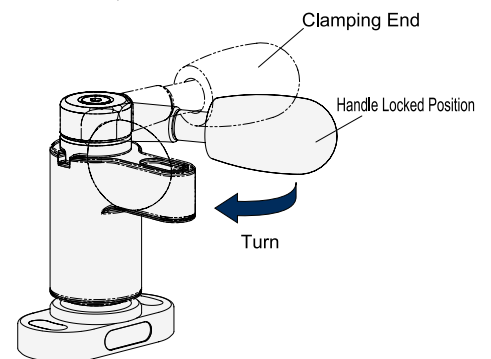

Turn the handle beyond the locked position until another click is made.

When the spindle is installed,

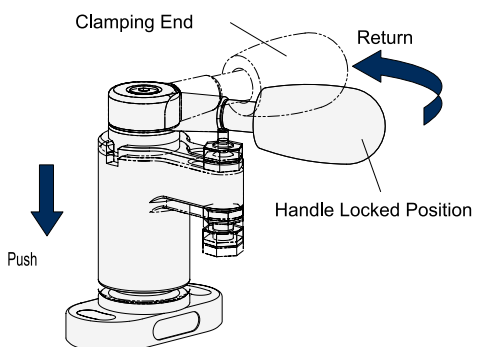

Lower the arm at the handle locked position and then return the handle keeping the arm lowered.

QLSWC

SWING CLAMPS (Mini) WITH CAM HANDLE



Body / Washer / Spindle	
Material	S45C steel
Finish	Black oxide
Heat treat	Quenched and tempered

Arm / Cam Shaft / Handle	
Material	SCM440 steel
Finish	Black oxide
Heat treat	Quenched and tempered

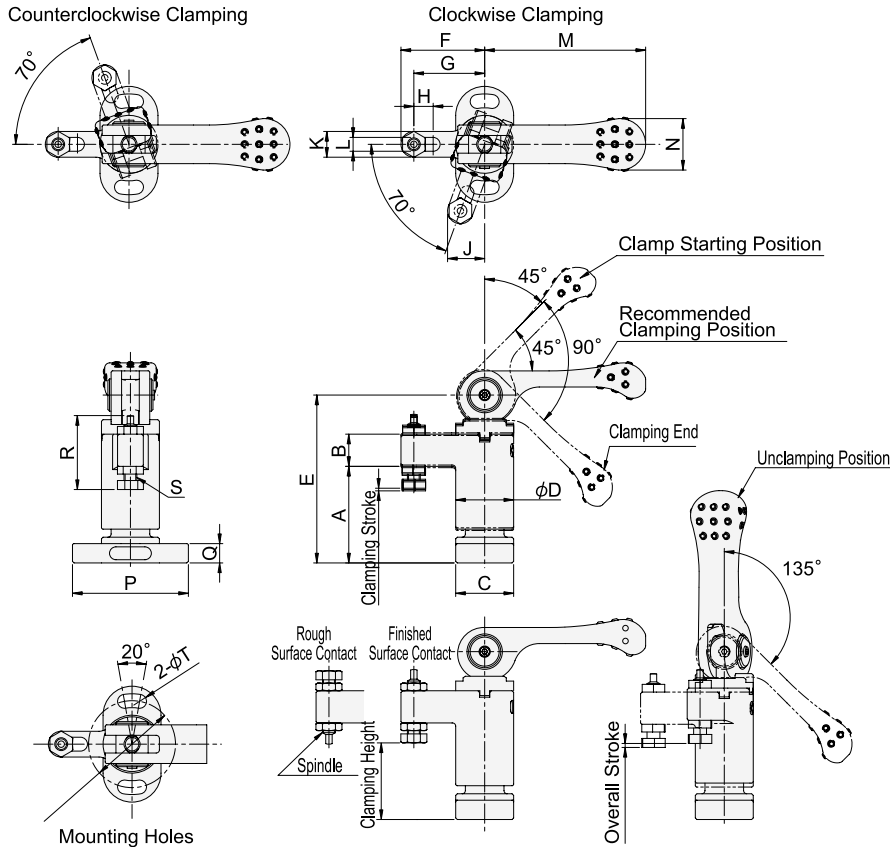

Part Number	Clamping Direction	Clamping Height *)				Clamping Stroke	Overall Stroke
		Finished Surface Contact		Rough Surface Contact			
		Min.	Max.	Min.	Max.		
51991826	Clockwise	22.8	24.8	22.4	24.4	0.8	1.2
51991827	Counterclockwise	(22.4-23.2)	(24.4-25.2)	(22-22.8)	(24-24.8)		
51991828	Clockwise	31.3	33.3	32.2	34.2	1	1.5
51991829	Counterclockwise	(30.8-31.8)	(32.8-33.8)	(31.7-32.7)	(33.7-34.7)		

*) Clamping height can be adjusted. The parenthesised values denote actual clamping height.

Part Number	A	B	C	D	E	F	G	H	J	K	L	M	N	P	Q
51991826	30	10	18	18	52	26	22	6	11.5	8	4.3	50	15	36	6
51991827															
51991828	40	14	23	23	68	35	30	8	15.3	10	5.3	63	20	45	8
51991829															

Part Number	R	S	T	U	Cam Handles Part Number	Allowable Operating Load (N) **)	Clamping Force (N)	Clamping Mechanism	Weight (g)
51991826	22.8	M4×0.7	4.3	27	QLCA-05	100	800	Spiral Cam Cam Angle:4°	134
51991827									272
51991828	28.5	M5×0.8	5.3	34	QLCA-06	150	1,500		
51991829									

***) Allowable load to operate the handle

How To Operate

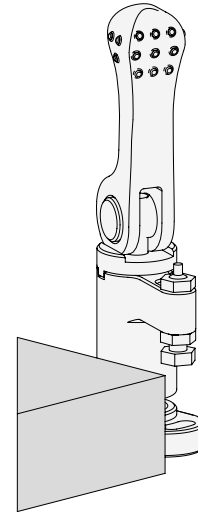

1. Unclamped
Load a workpiece.

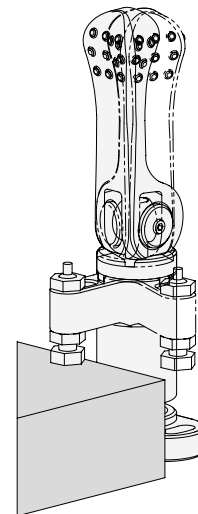

2. Arm Swing
Turn the handle to set the arm in position.

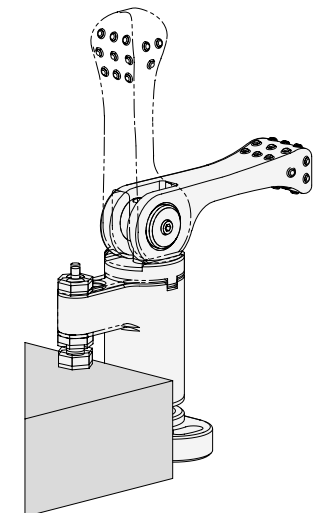

3. Clamping
Set the handle down to clamp the workpiece.

Performance Curve

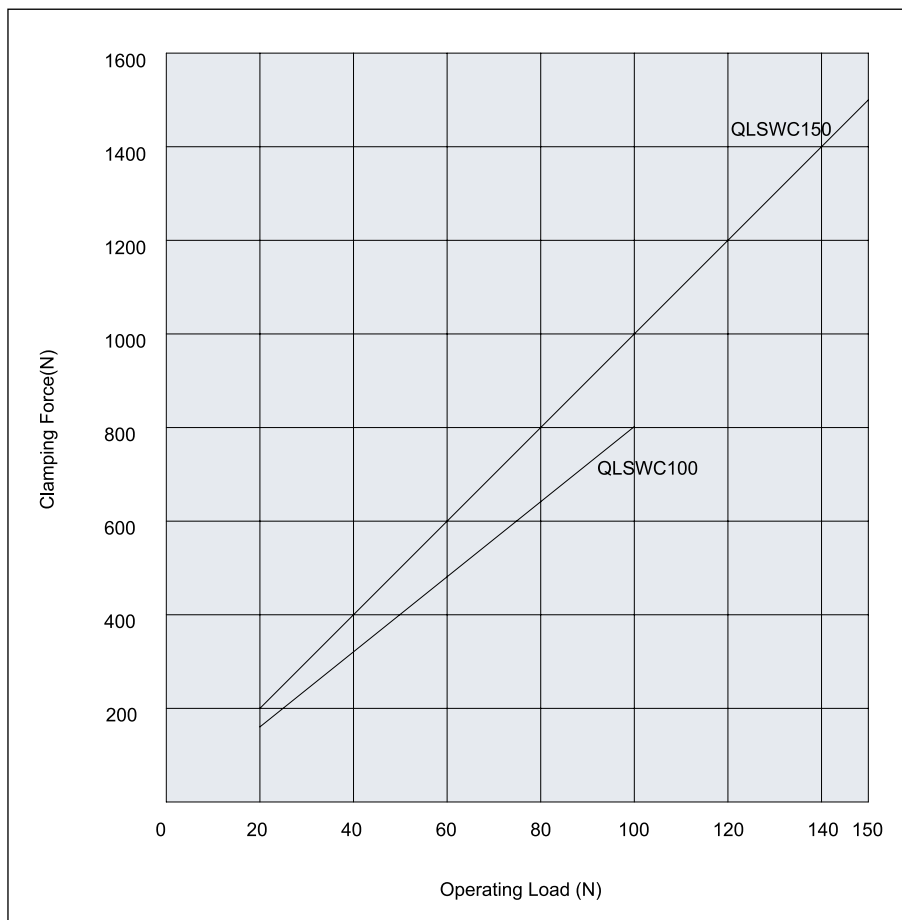

Technical Information

Allowable Loads in Machining of Workpiece Bottom

Ensure that any force more than stated below is not applied.

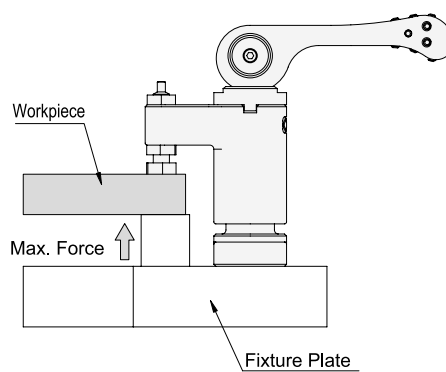

Series	Allowable Force to Workpiece Bottom (per Clamp)
QLSWC100	max.2,300N
QLSWC150	max.3,600N



Body / Washer / Flange Nut / Spindle	
Material	S45C steel
Finish	Black oxide
Heat treat	Quenched and tempered

Arm	
Material	SCM440 steel
Finish	Black oxide
Heat treat	Quenched and tempered

- Designed for clamping-force control with a torque wrench
- Screw clamping mechanism allows for longer clamping stroke and greater clamping force.

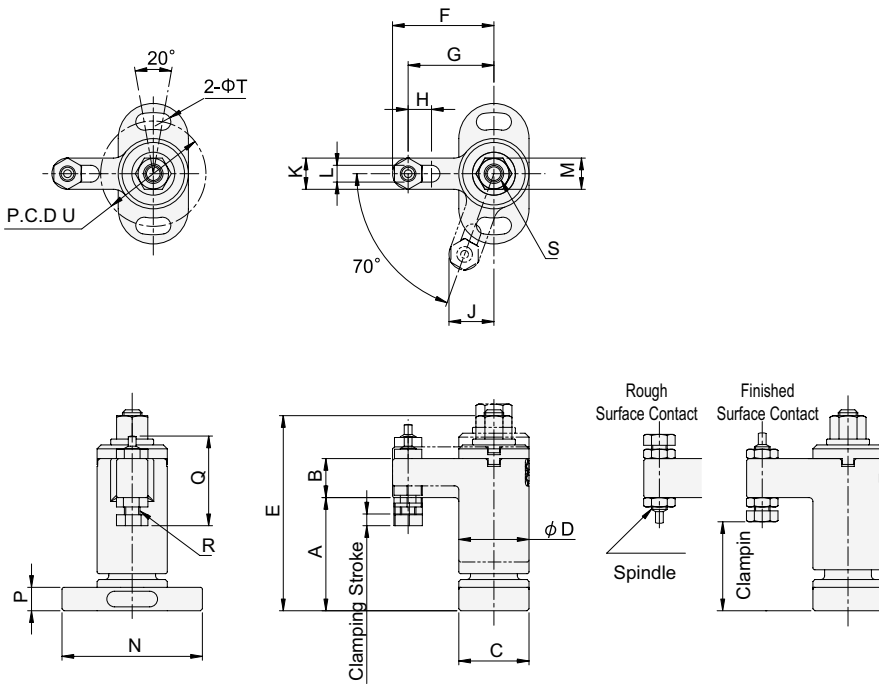

How To Operate

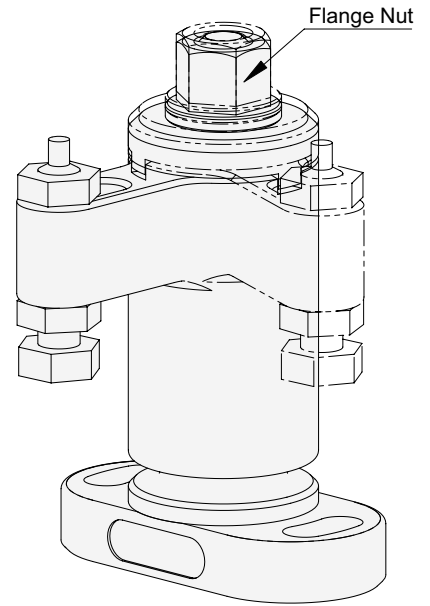

Turning the flange nut allows the arm to swing into position for clamping.

Warning

Do not use a power tool (impact wrench etc.) to turn the flange nut, for damage prevention.

Performance Curve

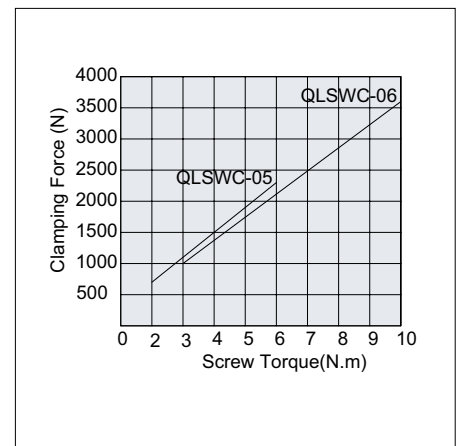

Part Number	Clamping Height *)				Clamping Stroke	A	B	C	D	E
	Finished Surface Contact		Rough Surface Contact							
	Min.	Max.	Min.	Max.						
51991830	22.8 (22.8-25.8)	24.8 (24.8-27.8)	22.4 (22.4-25.4)	24.4 (24.4-27.4)	3	29	10	18	18	52.5
51991831	31.3 (31.3-35.3)	33.3 (33.3-37.3)	32.2 (32.2-36.2)	34.2 (34.2-38.2)	4	39	14	23	23	69.5

*) Clamping height can be adjusted. The parenthesised values denote actual clamping height.

Part Number	F	G	H	J	K	L	M	N	P	Q
51991830	26	22	6	11.5	8	4.3	8	36	6	22.8
51991831	35	30	8	15.3	10	5.3	10	45	8	28.5

Part Number	R	S	T	U	Clamping Force(N)	Allowable Screw Torque (N.m)	Weight (g)
51991830	M4×0.7	M5×0.8	4.3	27	2,300	6	94
51991831	M5×0.8	M6×1	5.3	34	3,600	10	210

Fixturing with Swing Clamps(Mini)

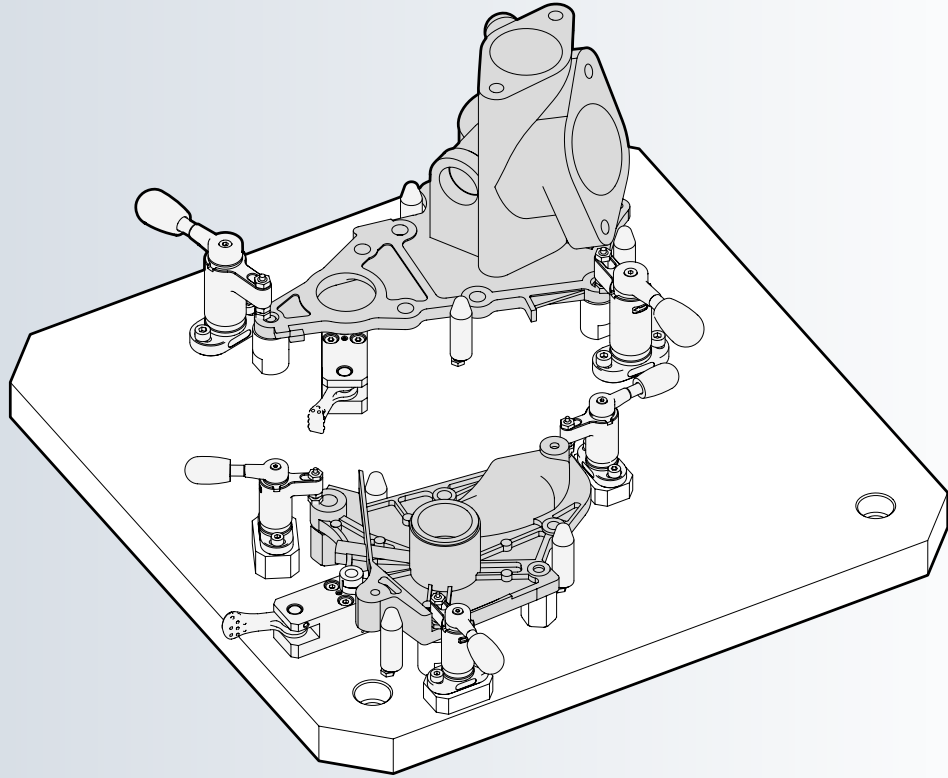

Fixturing with Swing Clamps(Mini) with Cam Handle

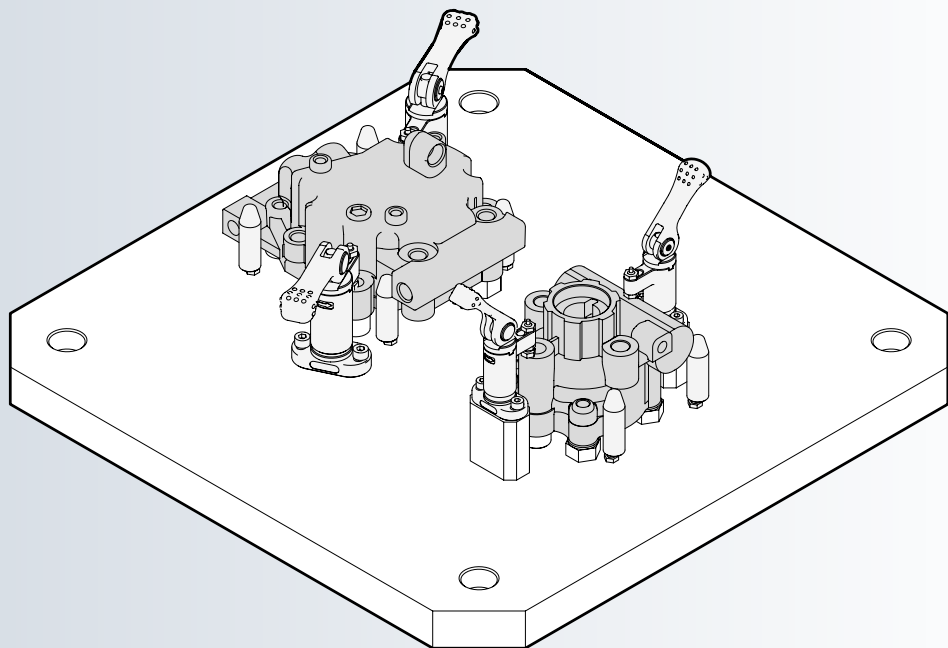



Body / Spindle	
Material	S45C steel
Finish	Black oxide
Heat treat	Quenched and tempered
Arm / Joint	
Material	SCM435 steel
Finish	Black oxide
Heat treat	Quenched and tempered
Cam Handle	
Material	SCM440 steel
Finish	Black oxide
Heat treat	Quenched and tempered

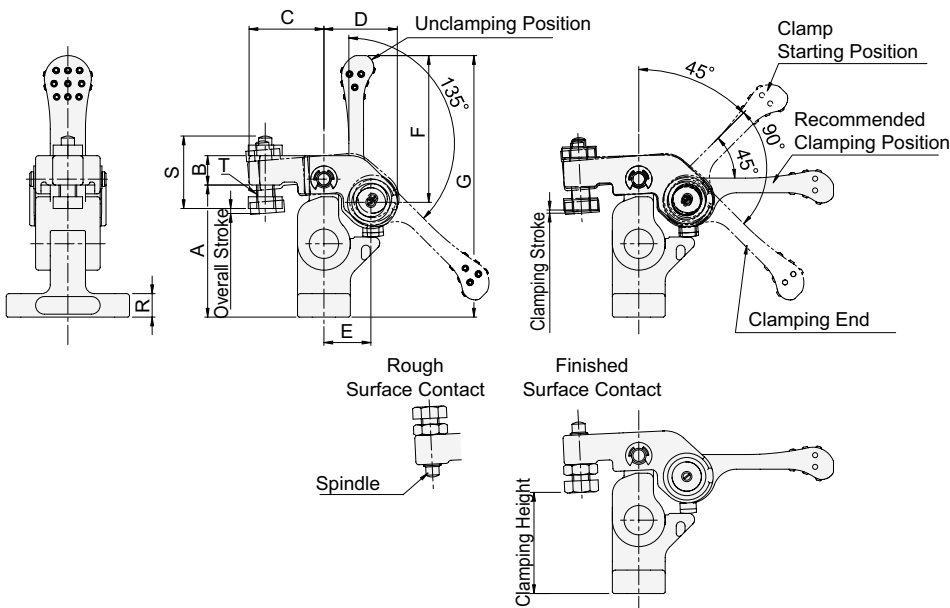
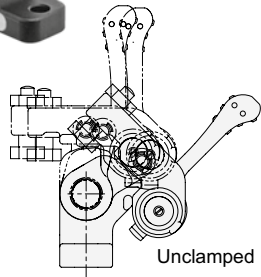
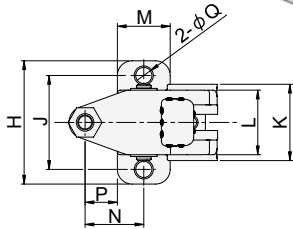

How To Operate

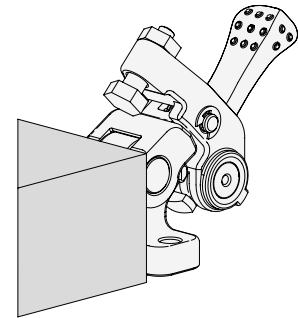

1. Unclamped
Load a workpiece.

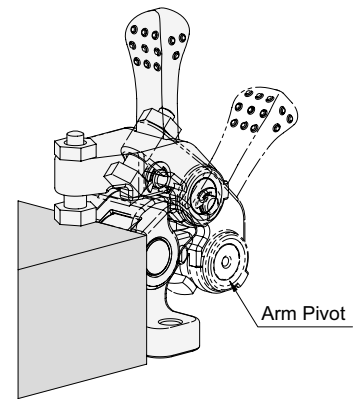

2. Clamping Setup
Set the arm in clamping position holding it at the arm pivot.

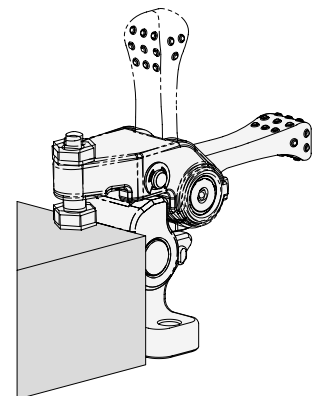

3. Clamping
Set the handle down to clamp the workpiece.
For unclamping, follow the above steps back.

Part Number	Clamping Height *)				Clamping Stroke	Overall Stroke
	Finished Surface Contact		Rough Surface Contact			
	Min.	Max.	Min.	Max.		
51991832	32 (31.5-32.5)	40 (39.5-40.5)	35 (34.5-35.5)	43 (42.5-43.5)	1	1.5
51991833	37 (36.4-37.6)	48 (47.4-48.6)	42 (41.4-42.6)	53 (52.4-53.6)	1.2	1.8

*) Clamping height can be adjusted. The parenthesised values denote actual clamping height.

Part Number	A	B	C	D	E	F	G	H	J	K	L	M	N	P	Q
51991832	45	10	25.5	25	16	50	89	42	32	26	22	18	20	11	5.5
51991833	55	12	32	31	20	63	109	52	40	32	28	22	25	14	6.6

Part Number	R	S	T	Cam Handles Part Number	Allowable Operating Load (N) **)	Clamping Force(N)	Clamping Mechanism	Weight (g)
51991832	8	24	M6×1	QLCA-05	100	700	Spiral Cam Cam Angle:4°	244
51991833	10	30.5	M8×1.25	QLCA-06	150	1,100		468

***) Allowable load to operate the handle

Performance Curve

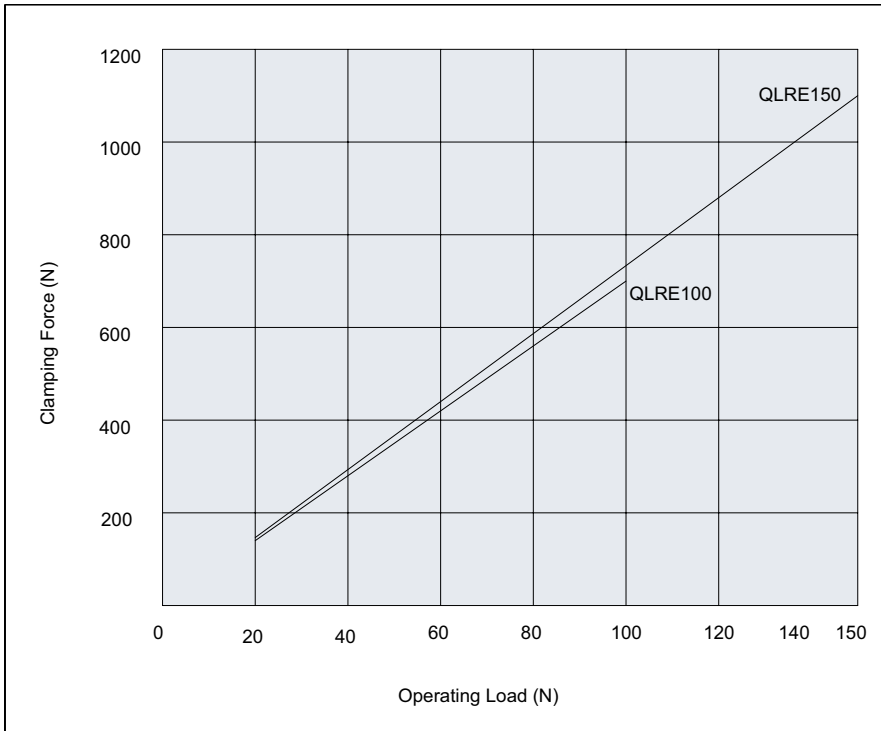

Technical Information

Allowable Loads in Machining of Workpiece Bottom

Ensure that any force more than stated below is not applied.

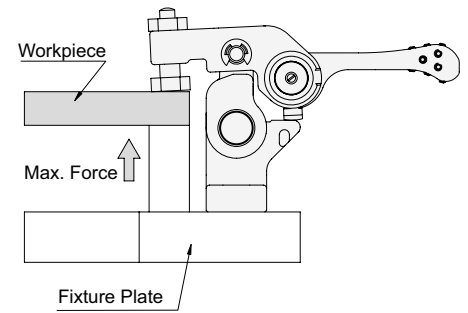

Part Number	Allowable Force to Workpiece Bottom (per Clamp)
51991832	max.5,000N
51991833	max.6,000N

APPLICATION EXAMPLES

Fixturing with Retractable Clamps (Mini) with Cam Handle

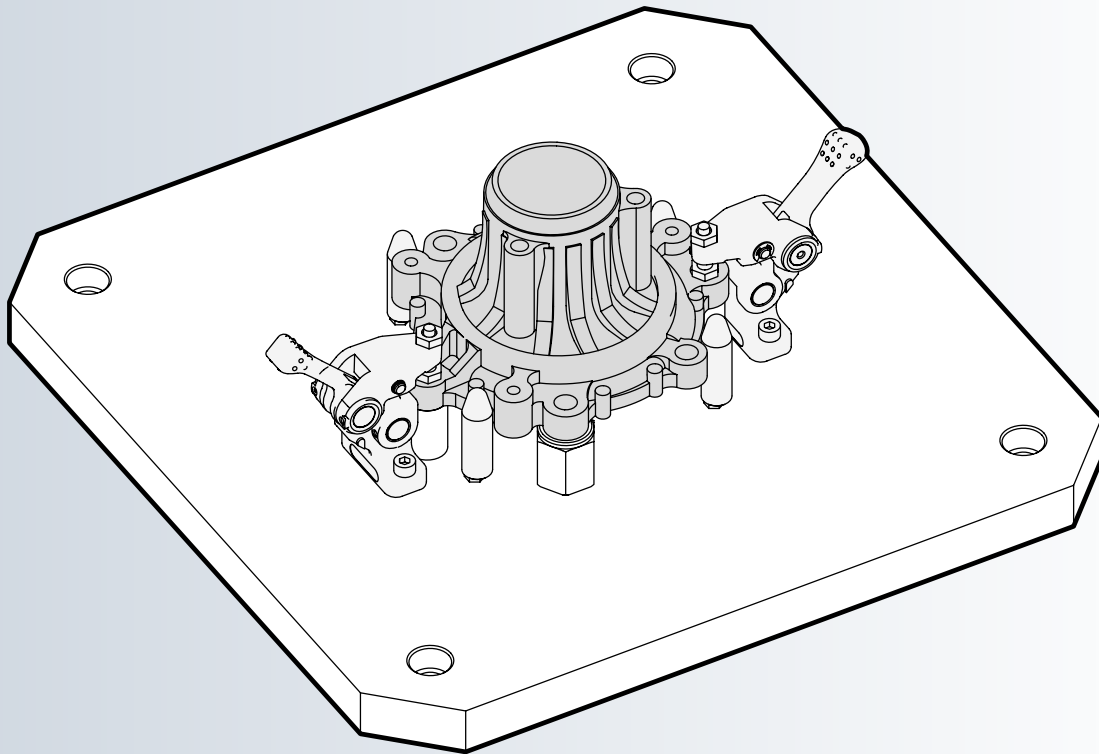



Body / Spindle	
Material	S45C steel
Finish	Black oxide
Heat treat	Quenched and tempered
Arm / Joint	
Material	SCM435 steel
Finish	Black oxide
Heat treat	Quenched and tempered

• Screw clamping mechanism allows for longer clamping stroke and greater clamping force.

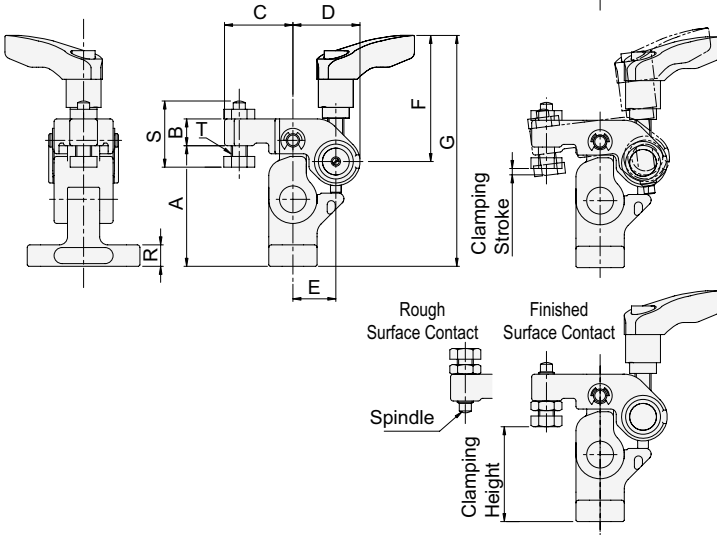
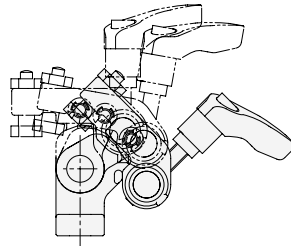
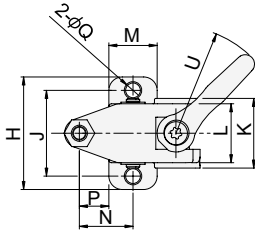

How To Operate

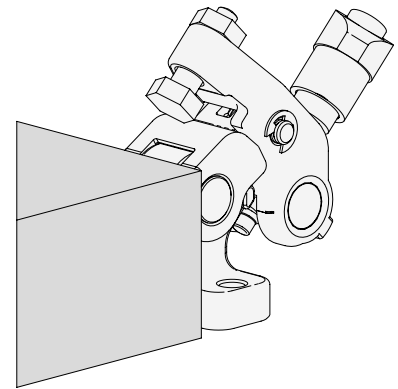

1. Unclamped
Load a workpiece.

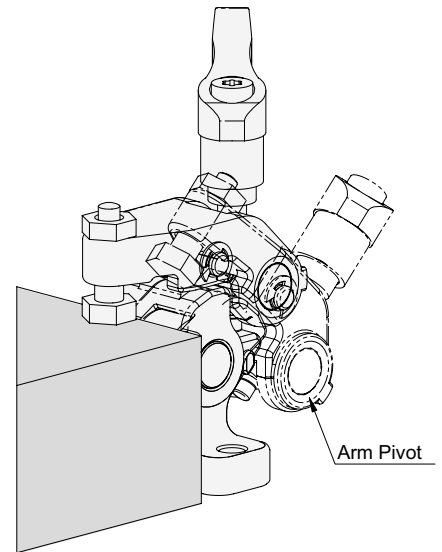

2. Clamping Setup
Set the arm in clamping position holding it at the arm pivot.

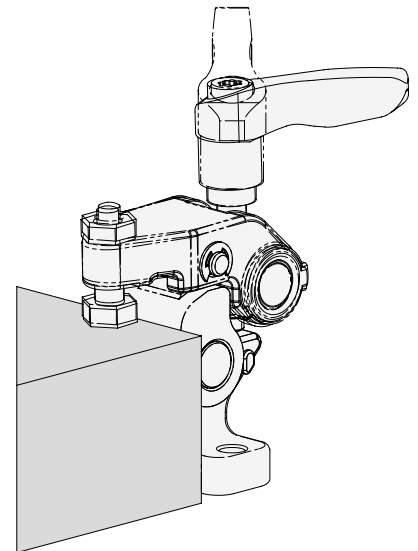

3. Clamping
Set the handle down to clamp the workpiece.

For unclamping, follow the above steps back.

Part Number	Clamping Height *)				Clamping Stroke	A	B	C	D	E
	Finished Surface Contact		Rough Surface Contact							
	Min.	Max.	Min.	Max.						
51991834	32 (32-29.5)	40 (40-37.5)	35 (35-32.5)	43 (43-40.5)	2.5	45	10	25.5	25	16
51991835	37 (37-33.5)	48 (48-44.5)	42 (42-38.5)	53 (53-49.5)	3.5	55	12	32	31	20

*) Clamping height can be adjusted. The parenthesised values denote actual clamping height.

Part Number	F	G	H	J	K	L	M	N	P	Q
51991834	47	86	42	32	26	22	18	20	11	5.5
51991835	63	109	52	40	32	28	22	25	14	6.6

Part Number	R	S	T	U	Adjustable Handles	Allowable Operating Load (N) **)	Clamping Force(N)	Clamping Mechanism	Weight (g)
51991834	8	24	M6×1	40	FKF6-BR	170	2,400	Screw	242
51991835	10	30.5	M8×1.25	65	FKF8-BR	210	4,200		490

***) Allowable load to operate the handle

Performance Curve

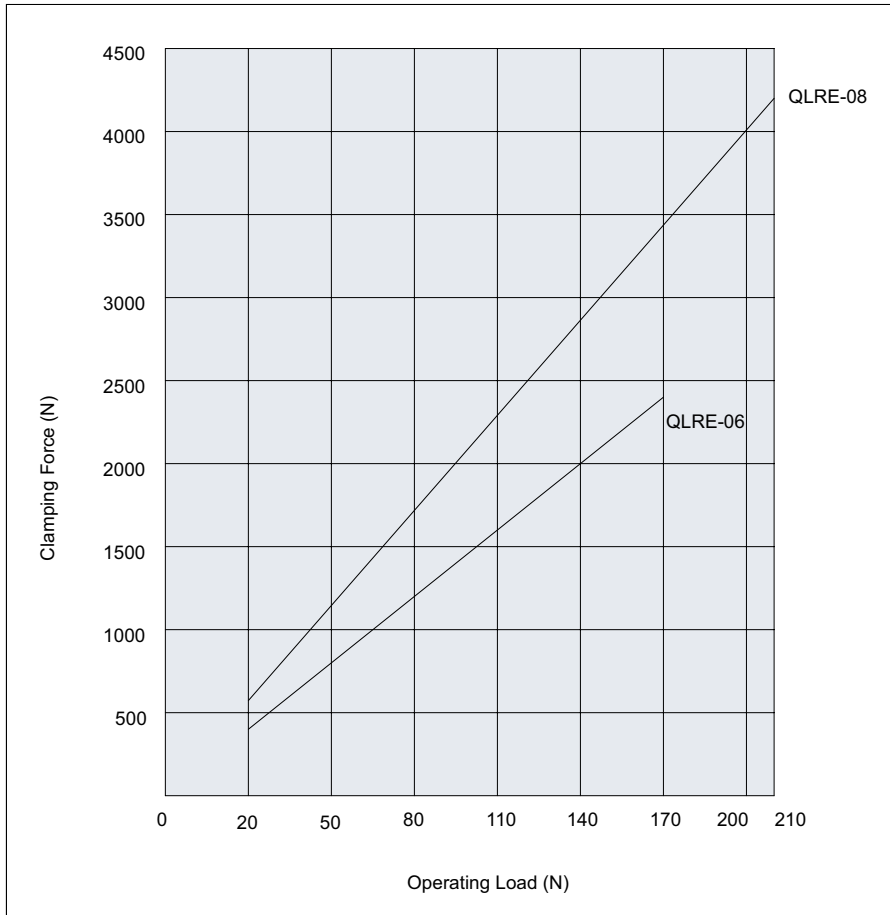

Technical Information

Allowable Loads in Machining of Workpiece Bottom

Ensure that any force more than stated below is not applied.

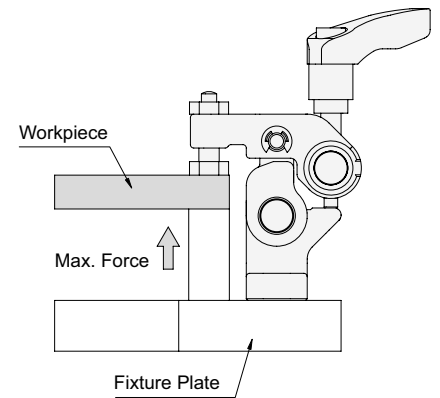

Part Number	Allowable Force to Workpiece Bottom (per Clamp)
QLRE-06	max.5.000N
QLRE-08	max.6.000N

APPLICATION EXAMPLES

Fixturing with Retractable Clamps (Mini) with Adjustable Handle

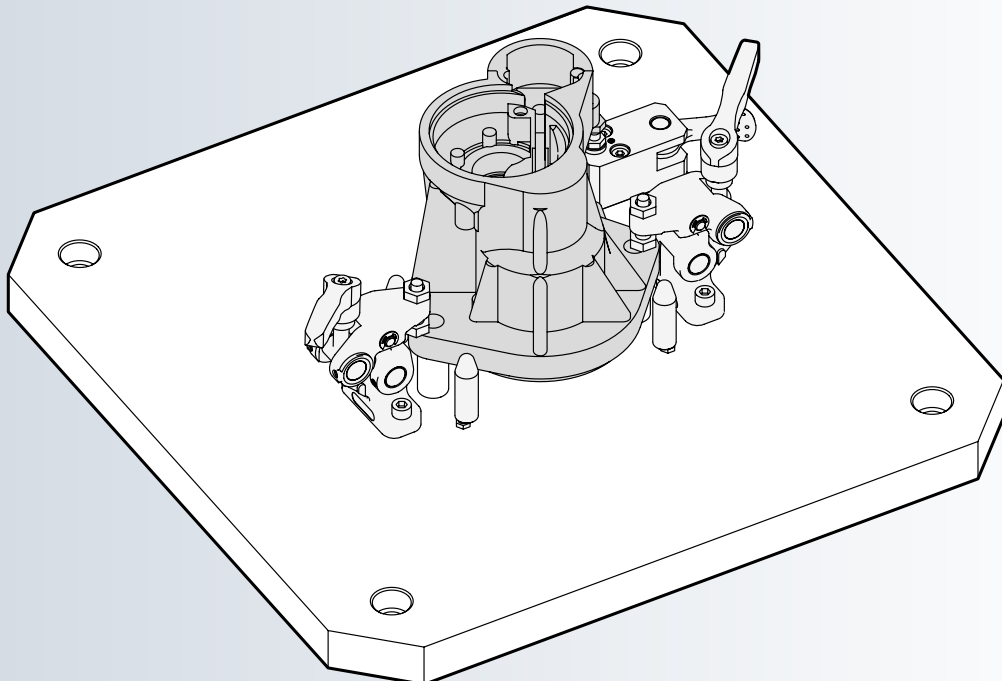

BJ352

WORK SUPPORT WITH CAM HANDLE

NEW

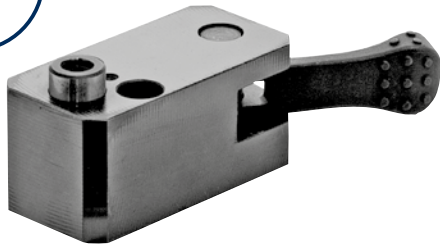

Body	
Material	S45C steel
Finish	Black oxide
Piston	
Material	SK4 steel
Finish	Black oxide
Heat treat	Quenched and tempered
Locking Pin	
Material	S45C steel
Finish	Black oxide
Heat treat	Quenched and tempered
Handle	
Material	SCM440 steel
Finish	Black oxide
Heat treat	Quenched and tempered

• The clamping direction can easily be changed.

How To Operate

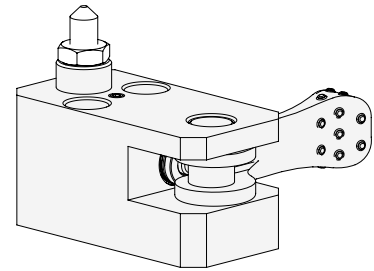

1. Unlocked
No workpiece loaded

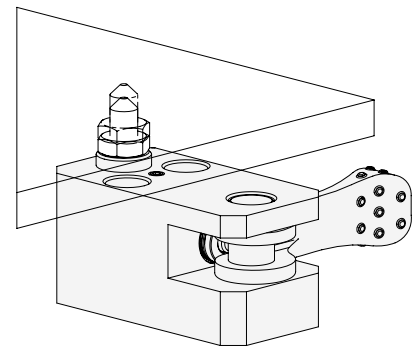

2. Workpiece Loading
Load a workpiece, and the piston lowers.

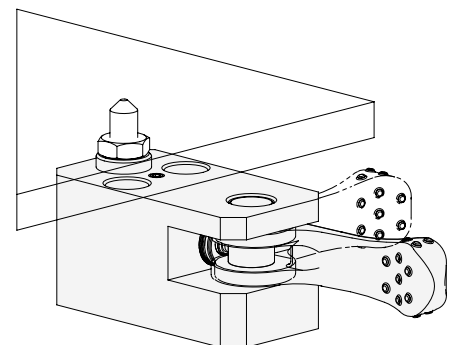

3. Clamping
Turn the handle to lock the piston.

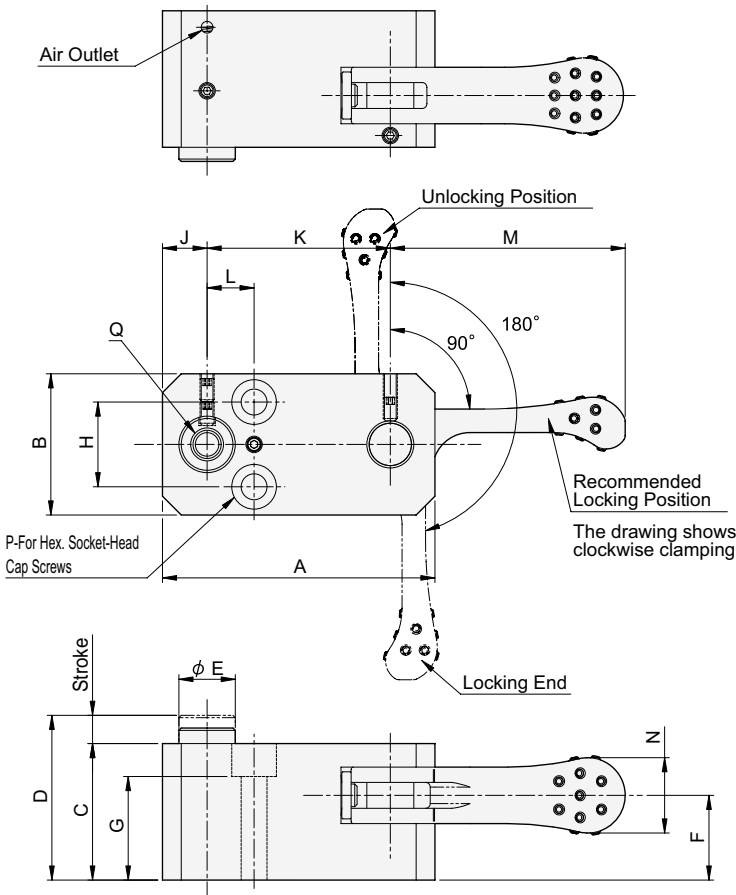

Part Number	A	B	C	D	E	F	G	H	J	K	L	M	N
51991836	52	25	24	29	10	14	19	15	8	36	8	40	14
51991837	58	30	29	35	12	18	22	18	9.5	39	10	50	16
51991838	75	38	37	45	16	23	25	24	12	51	12	63	19
51991839	85	45	42	52	19	26	30	28	14.5	56	15	80	24

Part Number	P	Q	Cam Handles Part Number	Allowable Operating Load (N) *)	Support Capacity (N)	Piston Spring Force (N)	Locking Mechanism	Weight (g)
51991836	M4	M5×0.8 8 deep	QLCA-04	80	500	0-6	Spiral Cam Cam Angle: 4°	213
51991837	M5	M6×1.10 deep	QLCA-05	100	700	0-6		335
51991838	M6	M8×1.25 15 deep	QLCA-06	150	900	0-7		738
51991839	M8	M10×1.5 15deep	QLCA-08	200	1,200	1-11		1,110

*) Allowable load to operate the handle

Adjusting Handle Locking Position

Ensure before use that the handle comes to the recommended position when the piston is locked, by adjusting the height of a support tip.

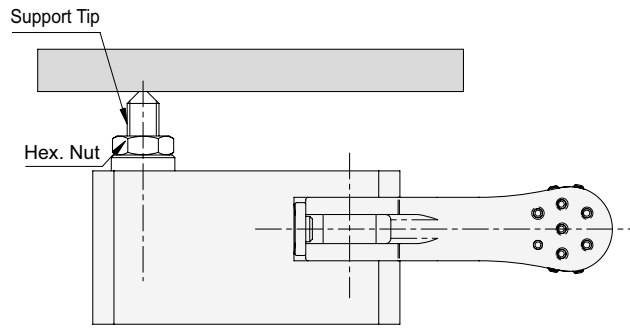

Changing Clamping Direction

Loosen the hex. socket setscrew to remove the retaining pin. Turn the handle upside down and put it in position again.

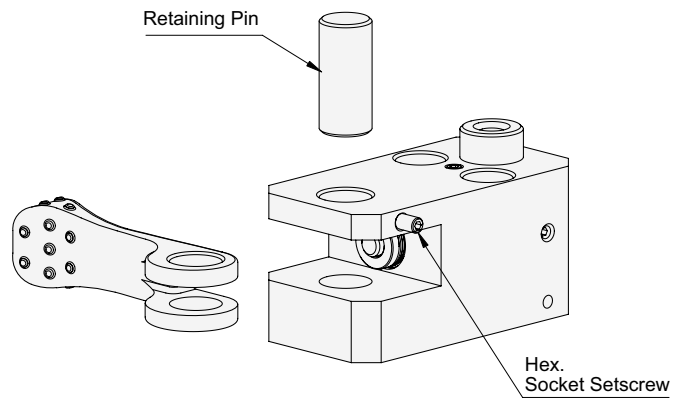
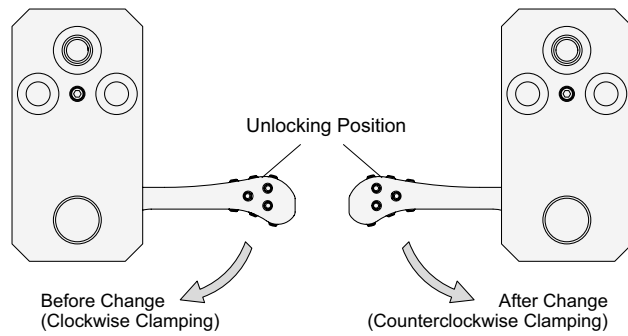

The built-in disc spring prevents loosened locking.

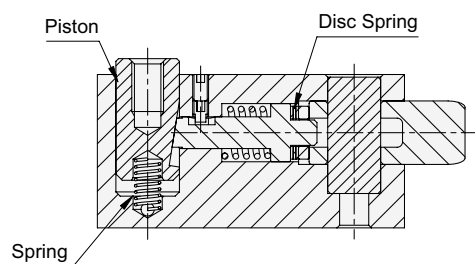



Material: Aluminum

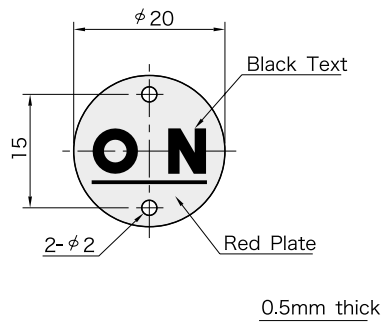

Pressure sensitive adhesive on the backside. Two 2mm-dia. holes allow for riveting.

How To Use

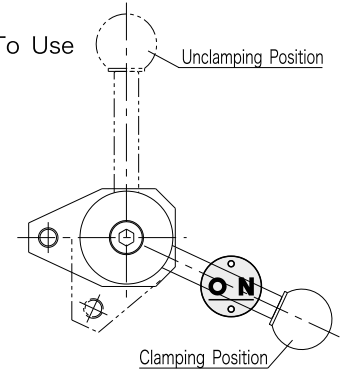

Use to mark the handle position in the clamping mode.

Part Number

51991147



Lever	
Material	SCM440 steel
Finish	Black oxide
Heat treat	Quenched and tempered
Ring Nut / Washer	
Material	S45C steel
Finish	Black oxide
Heat treat	Quenched and tempered

Installing the cam handle

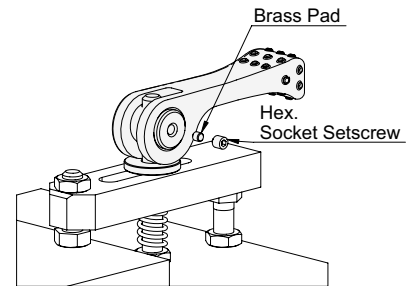

Use a brass pad and a hex. socket setscrew included.

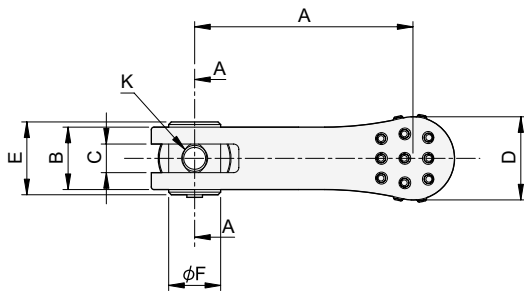

Application Example

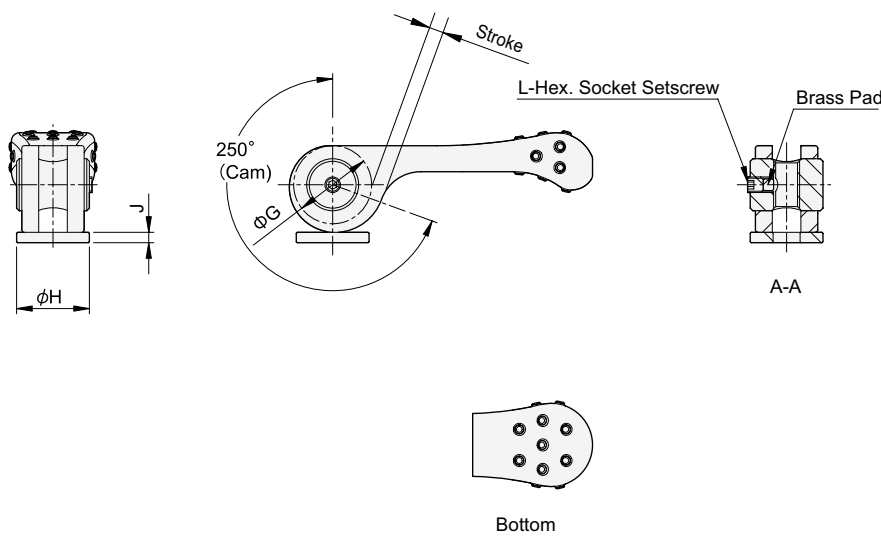
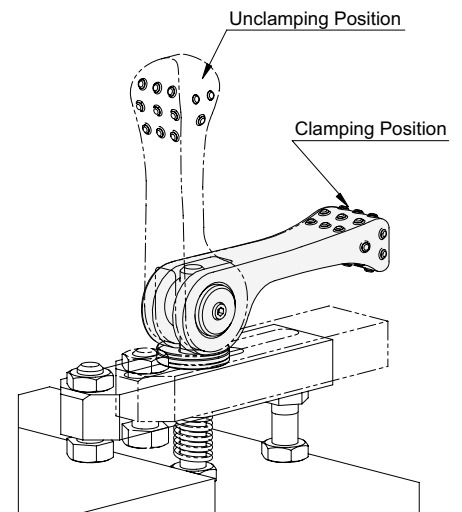

Part Number	A	B	C	D	E	F	G	H	J
51991858	40	10	4.5	14	12	8	12	12	2
51991859	50	12	5.5	16	14	10	15	14	2
51991860	63	14	6.5	19	16	12	18	16	3
51991861	80	18	9	24	20	15	22	20	3

Part Number	K	L	Stroke	Allowable Operating Load (N) *	Clamping Force(N)	Clamping Mechanism	Weight (g)
51991858	M4×0.7	M3×0.5-3L	1.8	80	900	Spiral Cam Cam Angle:4°	26
51991859	M5×0.8	M3×0.5-3L	2.3	100	1,300		46
51991860	M6×1	M4×0.7-4L	2.7	150	2,600		80
51991861	M8×1.25	M4×0.7-4L	3.3	200	4,000		154

*) Allowable load to operate the handle

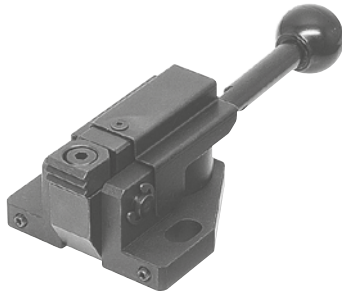

With Handle

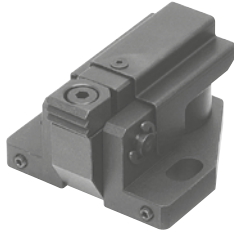

Without Handle

Base	
Material	S45C steel
Finish	Quenched and tempered
Jaws	
Material	SKH51 steel
Finish	Quenched and tempered
Cam	
Material	SK4 steel
Finish	Quenched and tempered
Handle	
Material	S45C steel
Finish	Black oxide
Ball Knob	
Material	ABS resin
Finish	Black

How To Use

The long mounting holes allow adjusting the clamping range. Tightening the hex socket setscrews in the base front allows preventing the clamp from sliding back in the clamping mode.

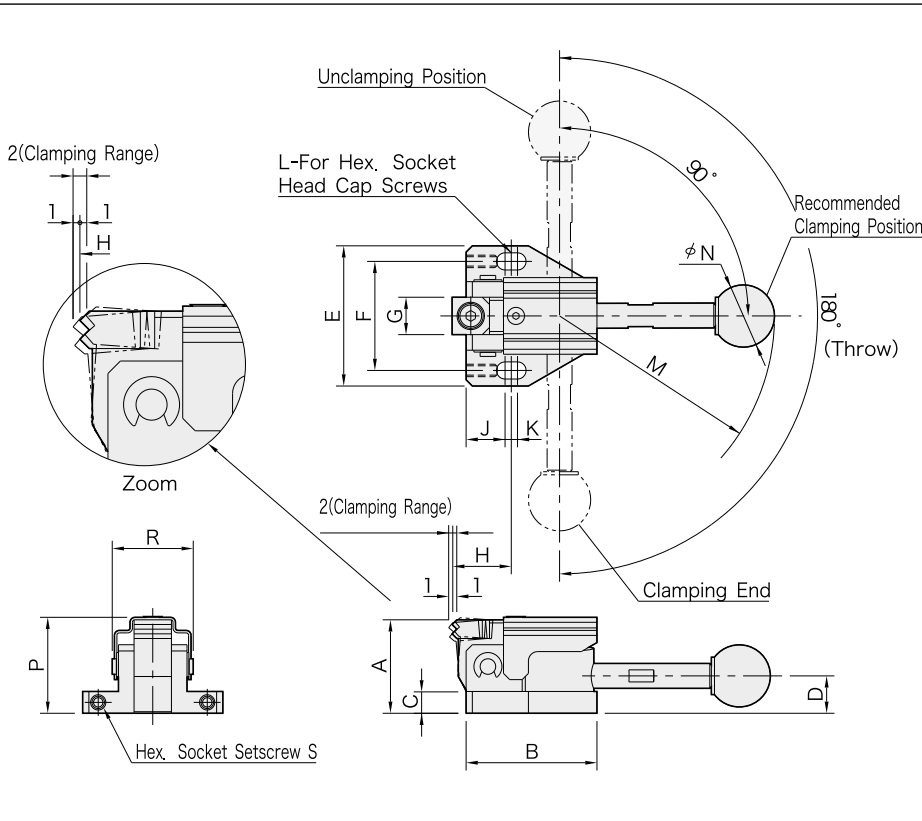
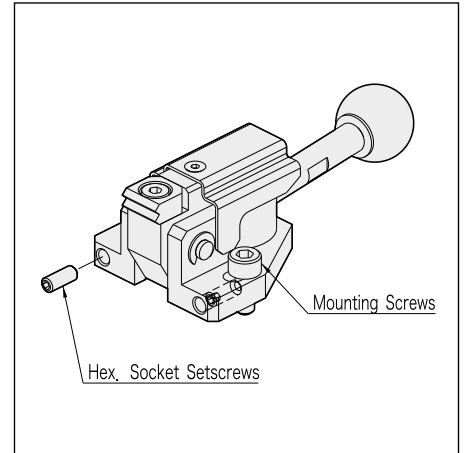

Dimensions of Jaw Base

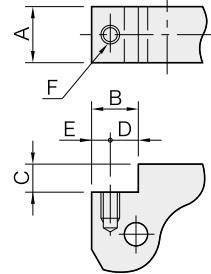

Size	A	B	C	D	E	F
QLSC150	12	10	6	6	4	M4x0.7 7 deep
QLSC200	16	14.5	10	8	6.5	M6x1 9 deep

Jaw Customization

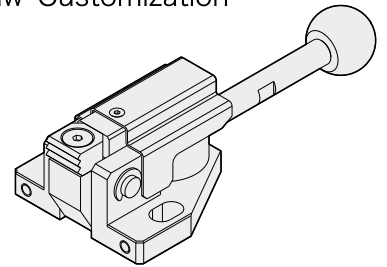

Size	A	B	C	D	E	F	G	H	J	K	L	P
QLSC150	30	42	7	12	45	35	12	19	12.5	4	M5	31
QLSC200	40	62	10	16	65	50	16	28	18.5	5	M8	41

Size	R	S	Clamping Force(N)	Clamping Mechanism
QLSC150	26	M4x0.7-10L	3000	Spiral Cam Cam Angle:4°
QLSC200	38	M4x0.7-15L	4000	

With Handle

Part Number	M	N	Allowable Operating Load (N) *	Weight (g)
51991125	69	20	150	210
51991126	104	25	200	580

Without Handle

Part Number	Weight (g)
51991127	185
51991128	530

Note: The handle must be ordered separately.

*) Allowable load to operate the handle

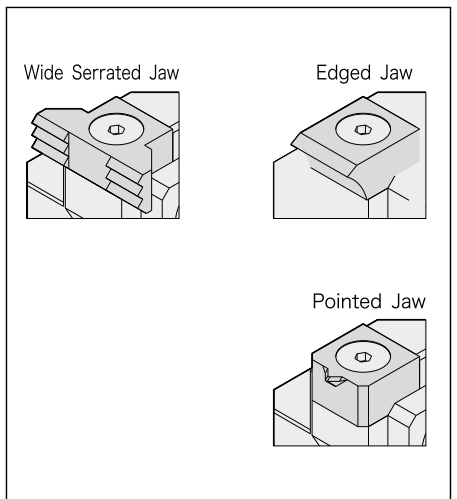

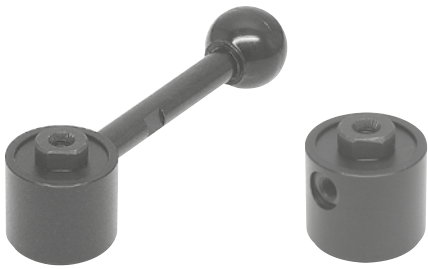

With Handle

Without Handle

Cam	
Material	SK4 steel
Finish	Quenched and tempered
Piston	
Material	S45C steel
Finish	Quenched and tempered
Handle	
Material	S45C steel
Finish	Black oxide
Ball Knob	
Material	ABS resin
Finish	Black

Application Examples

Downthrust Clamping

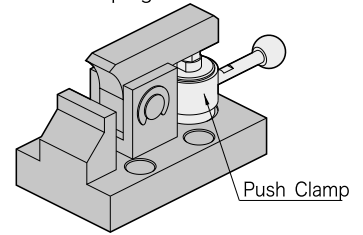

Downward Clamping

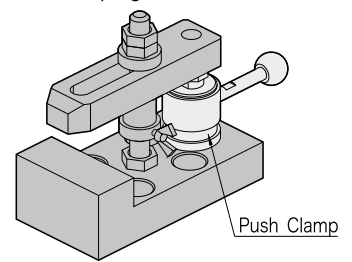

Sideways Clamping

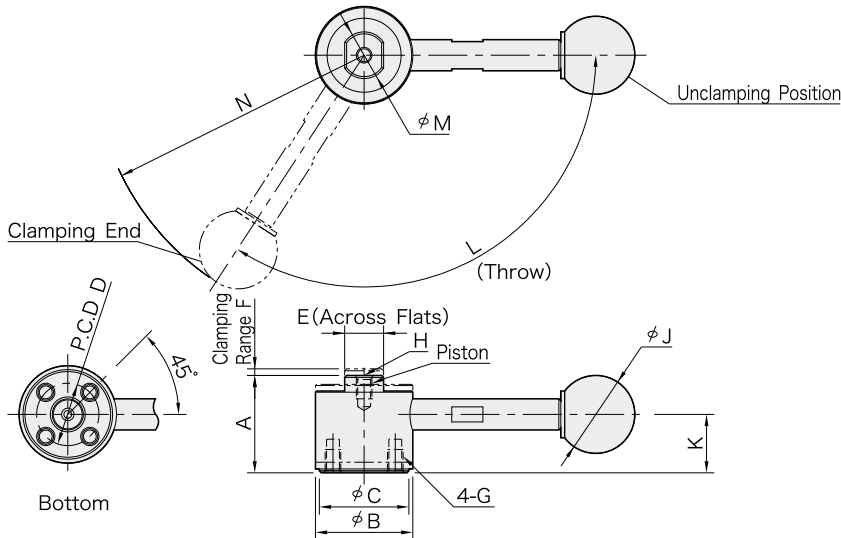
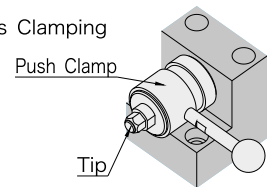

Series	A	B	C	D (P.C.D)	E	F	G	H	K	L	M	Clamping Force(N)	Clamping Mechanism
QLPU150	25	25	23	16	10	1.7	M4x0.7 6 deep	M4x0.7 6 deep	15	123°	12	3000	Spiral Cam
QLPU200	32	32	30	20	13	2.5	M6x1 9 deep	M6x1 9 deep	19.5	135°	15	4000	Cam Angle:4°

With Handle

Part Number	J	N	Allowable Operating Load (N) *	Weight (g)
51991129	20	69.5	150	180
51991130	25	103	200	370

Without Handle

Part Number	Weight (g)
51991131	150
51991132	310

Note: The handle must be ordered separately.

*) Allowable load to operate the handle

When installing a tip on the piston, lock the piston using a wrench to prevent the clamp from receiving any torque.

Note : See page 151 and 154 for performance curves.

QLSL Screw-In Handles



Handle	
Material	S45C steel
Finish	Black oxide
Ball Knob	
Material	ABS resin
Finish	Black

QLSL-RL Plug-In Handles



Handle	
Material	S45C steel
Finish	Black oxide
Ball Knob	
Material	ABS resin
Finish	Black

QLSL-RA Plug-In Handles adaptors



Material	SCM440 steel
Finish	Quenched and tempered

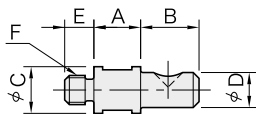
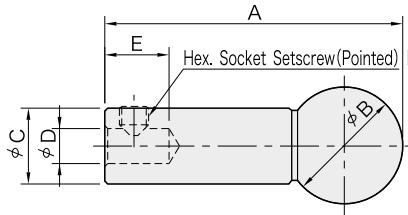
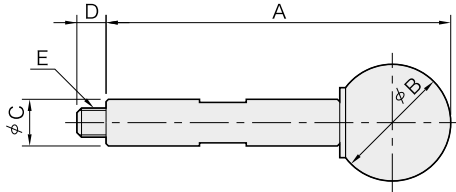

How To Use

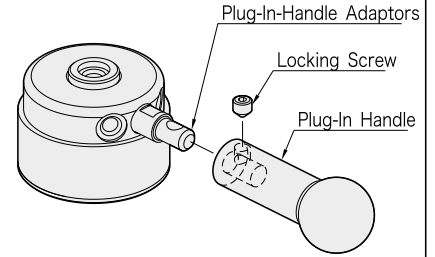

Secure the Plug-In Handle to the Adaptor using the locking screw if necessary.

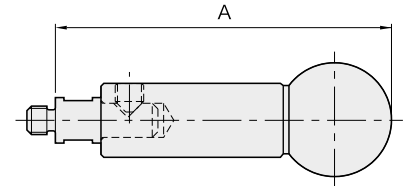

Plug-In Handle Coupled with the Adaptor

Size	A
QLSL150	59
QLSL200	89

QLSL (Screw-in Handles)

Part Number	A	B	C	D	E	Weight (g)
51991135	59	20	8	5	M5x0.8	30
51991136	89	25	10	6	M6x1	60

QLSL-RL(Plug-In Handles)

Part Number	A	B	C	D	E	F	Weight (g)
51991137	51	20	13	6	11	M5x0.8-5L	45
51991138	79	25	15	8	13	M6x1 -6L	90

QLSL-RA(Plug-In-Handle Adaptors)

Part Number	A	B	C	D	E	F	Weight (g)
51991139	8	10	8	6	5	M5x0.8	7
51991140	10	12	10	8	6	M6x1	14

Performance Curves

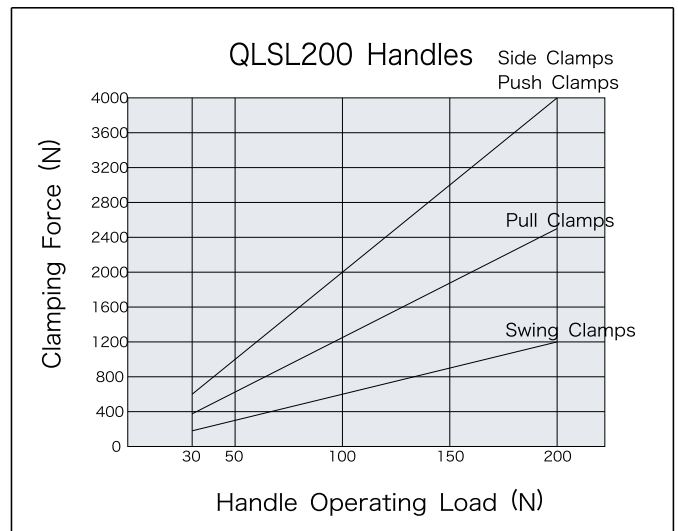
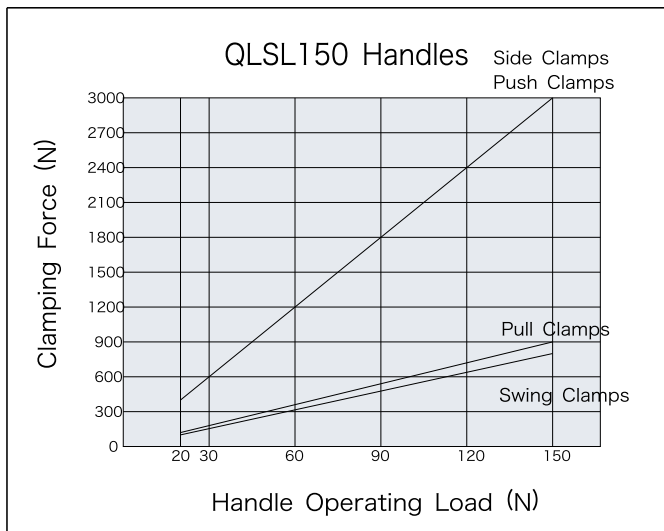

How To Use

Turning the setscrew inside the handle allows adjusting the torque to set a desired clamping force.

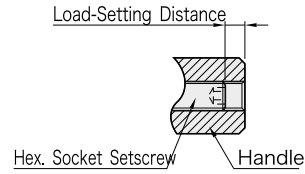

[Operating-Load Setting Range]

QLTL120/QLTL120-RL : 30N to 120N
 QLTL160/QLTL160-RL : 50N to 160N

Note : Ensure that the operating load is not set below the lower limit to prevent the handle from returning to the unclamping position due to shock load generated during the transfer of machine pallets.

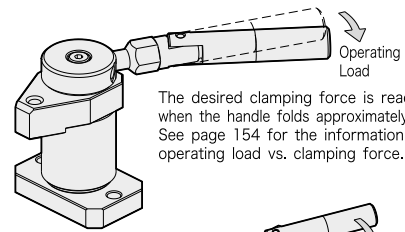

The desired clamping force is reached when the handle folds approximately 15°. See page 154 for the information on operating load vs. clamping force.

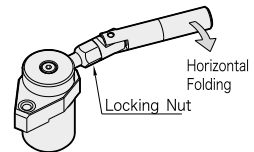

Note : Ensure that the handle is set to fold horizontally.

Plug-In Handle Installation

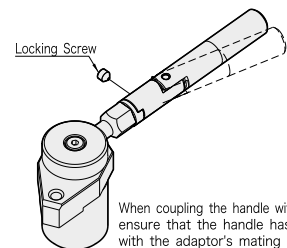
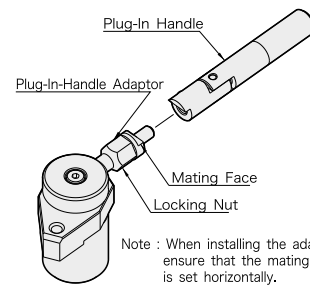

QLTL (Screw-In Handles)

QLTL-RL (Plug-In Handles)

QLTL-RA (Plug-In-Handle Adaptors)

Stem	
Material	SCM440 steel
Finish	Quenched and tempered

Lockin nut	
Material	S45C steel
Finish	Black oxide

Handle	
Material	S45C steel
Finish	Quenched and tempered

QLTL (Screw-In Handles)

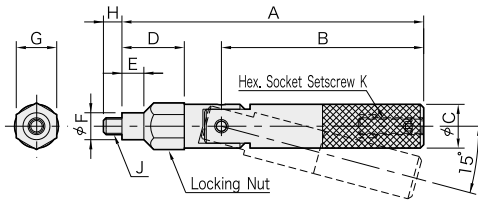

QLTL-RL (Plug-In Handles)

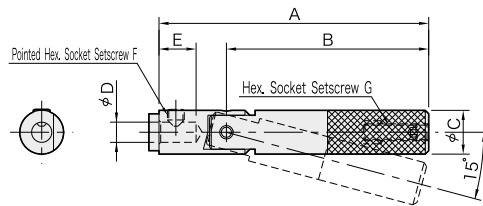

QLTL-RA (Plug-In-Handle Adaptors)

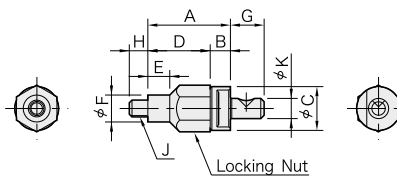

QLTL (Screw-In Handles)

Part Number	A	B	C	D	E	F	G	H	J	K	Weight (g)
51991141	89.5	60	13	18.5	6.5	8	12	5.5	M5x0.8	M5x0.8-16L	90
51991142	119	84	15	23	8	10	14	6.5	M6x1	M6x1 -20L	140

QLTL-RL (Plug-In Handles)

Part Number	A	B	C	D	E	F	G	Weight (g)
51991143	80	60	13	6	11	M5x0.8-5L	M5x0.8-16L	70
51991144	107	84	15	8	13	M6x1 -6L	M6x1 -20L	130

QLTL-RA (Plug-In-Handle Adaptors)

Part Number	A	B	C	D	E	F	G	H	J	K	Weight (g)
51991145	24.5	6	13	18.5	6.5	8	10	5.5	M5x0.8	6	20
51991146	30	7	15	23	8	10	12	6.5	M6x1	8	40

Plug-In Handle Coupled with the Adaptor

Part Number	A
51991143	104.5
51991145	
51991144	137
51991146	

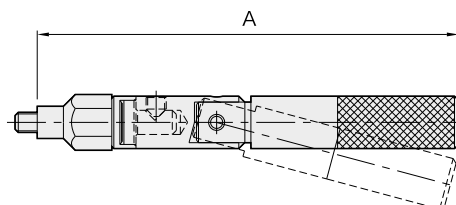

Performance Curves

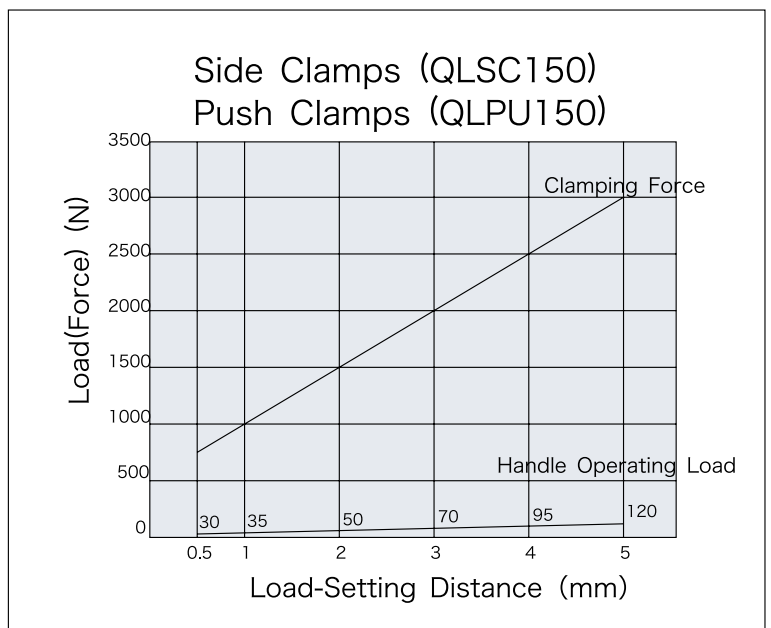
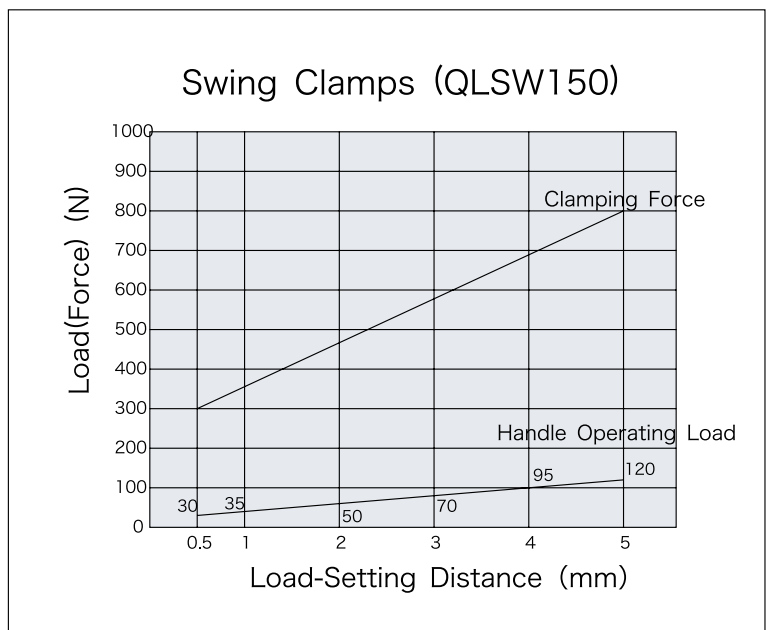
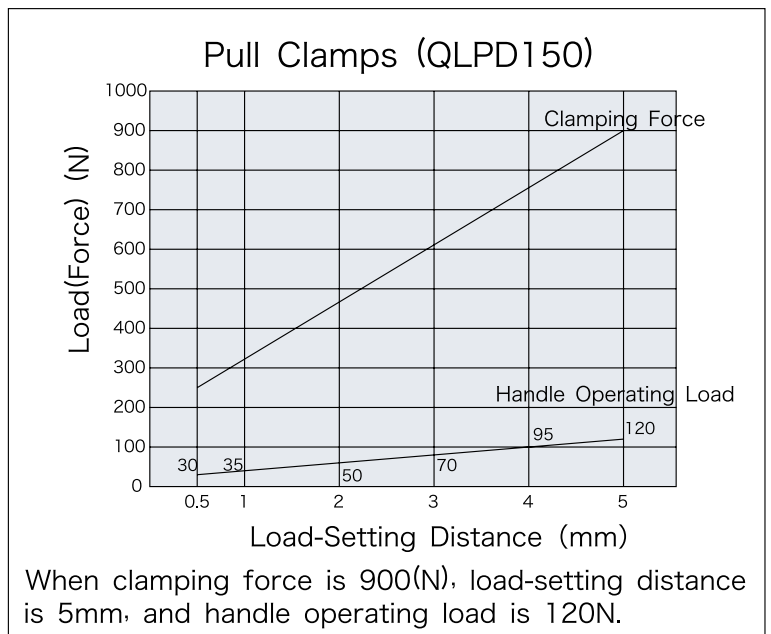
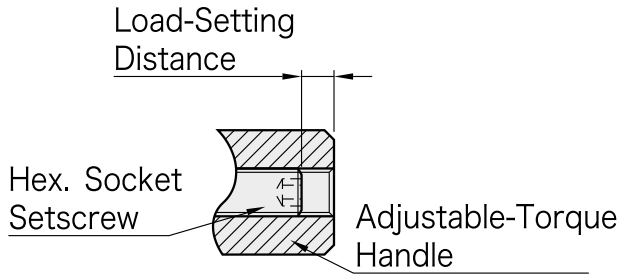

Note : The above performance curves apply when clamps are degreased.

Pull Clamps (QLPD200)

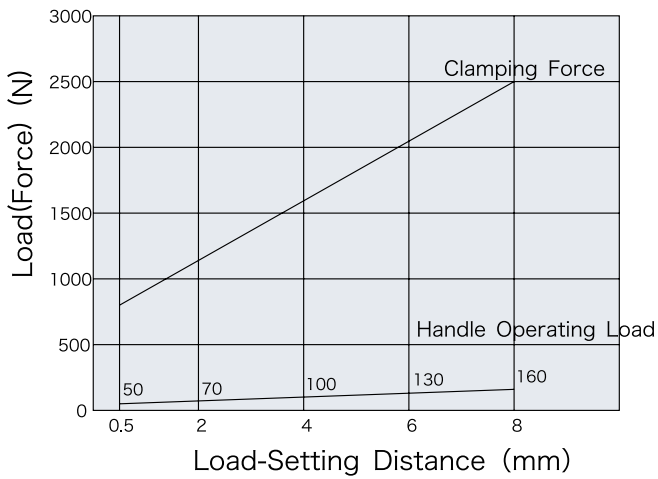

Swing Clamps (QLSW200)

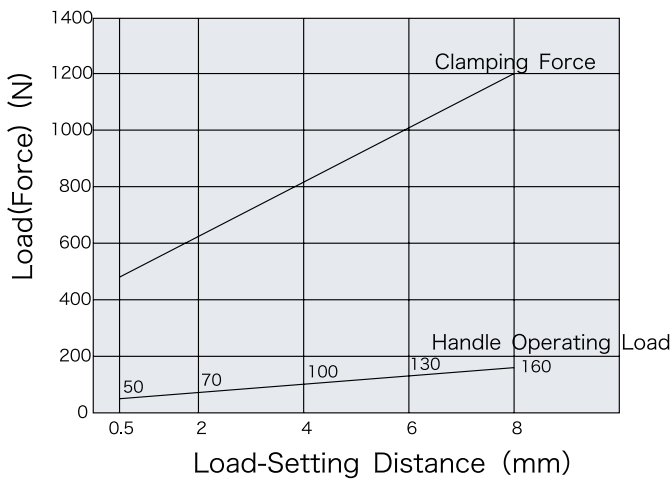

Side Clamps (QLSC200) Push Clamps (QLPU200)

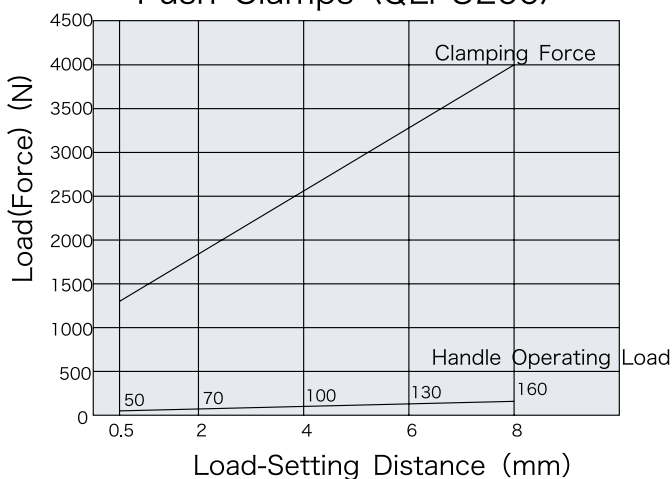

Note : The above performance curves apply when clamps are degraded.

APPLICATION EXAMPLES

Pull Clamps

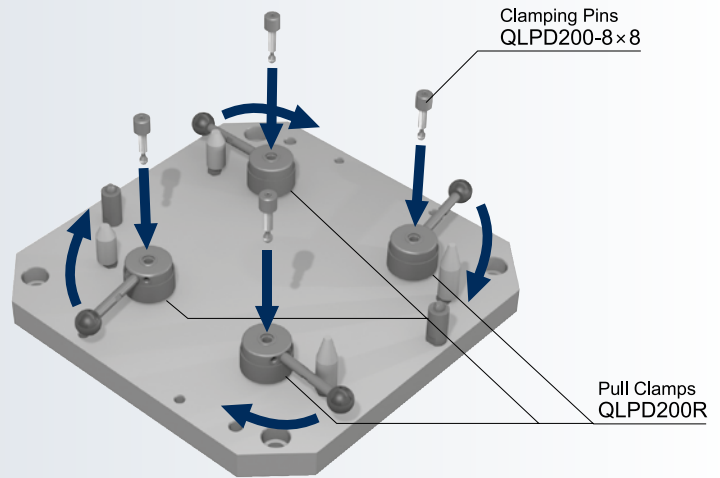
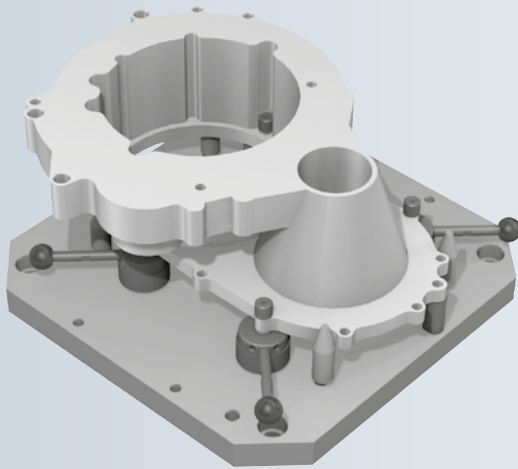

Swing Clamps

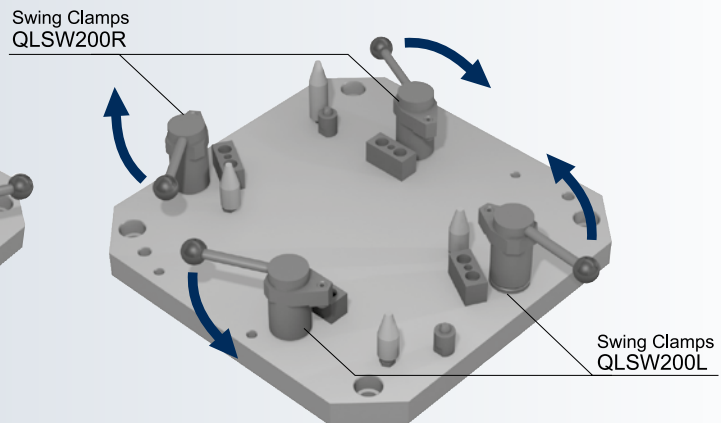
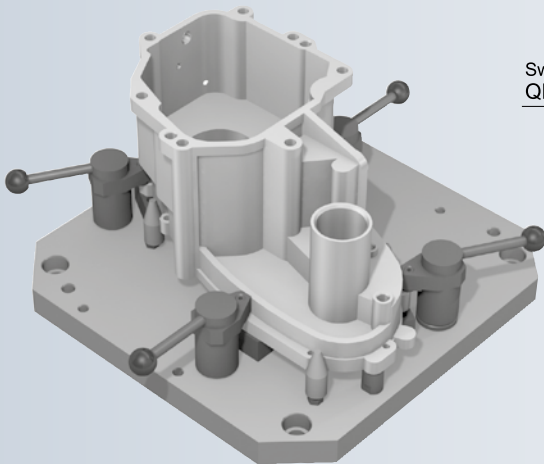

Side Clamps

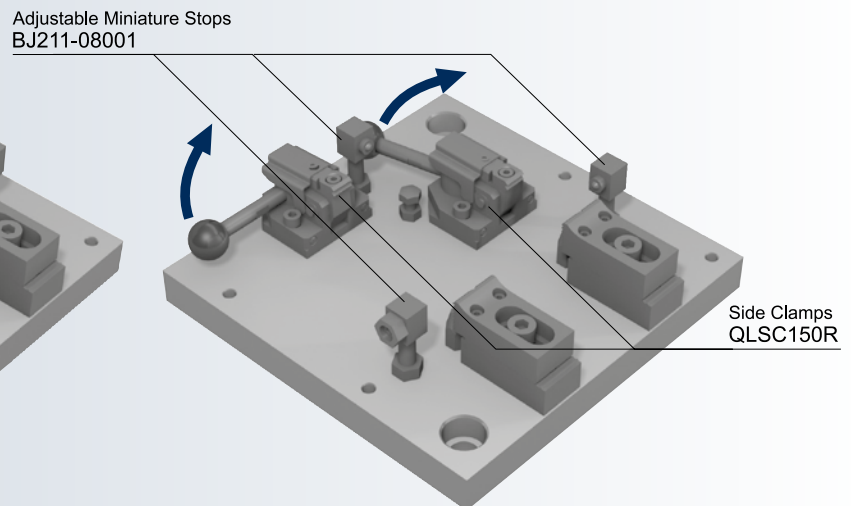
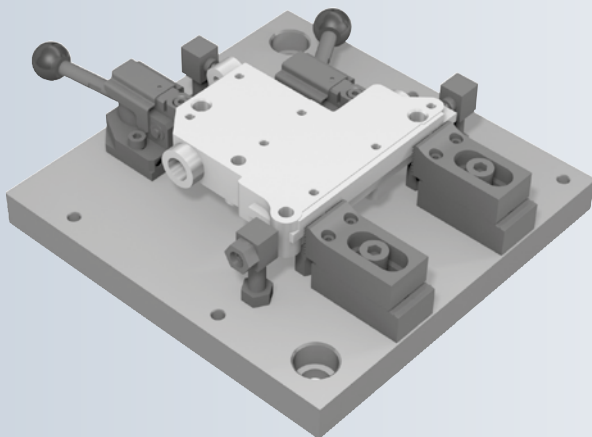

Actual Applications of Swing Clamps

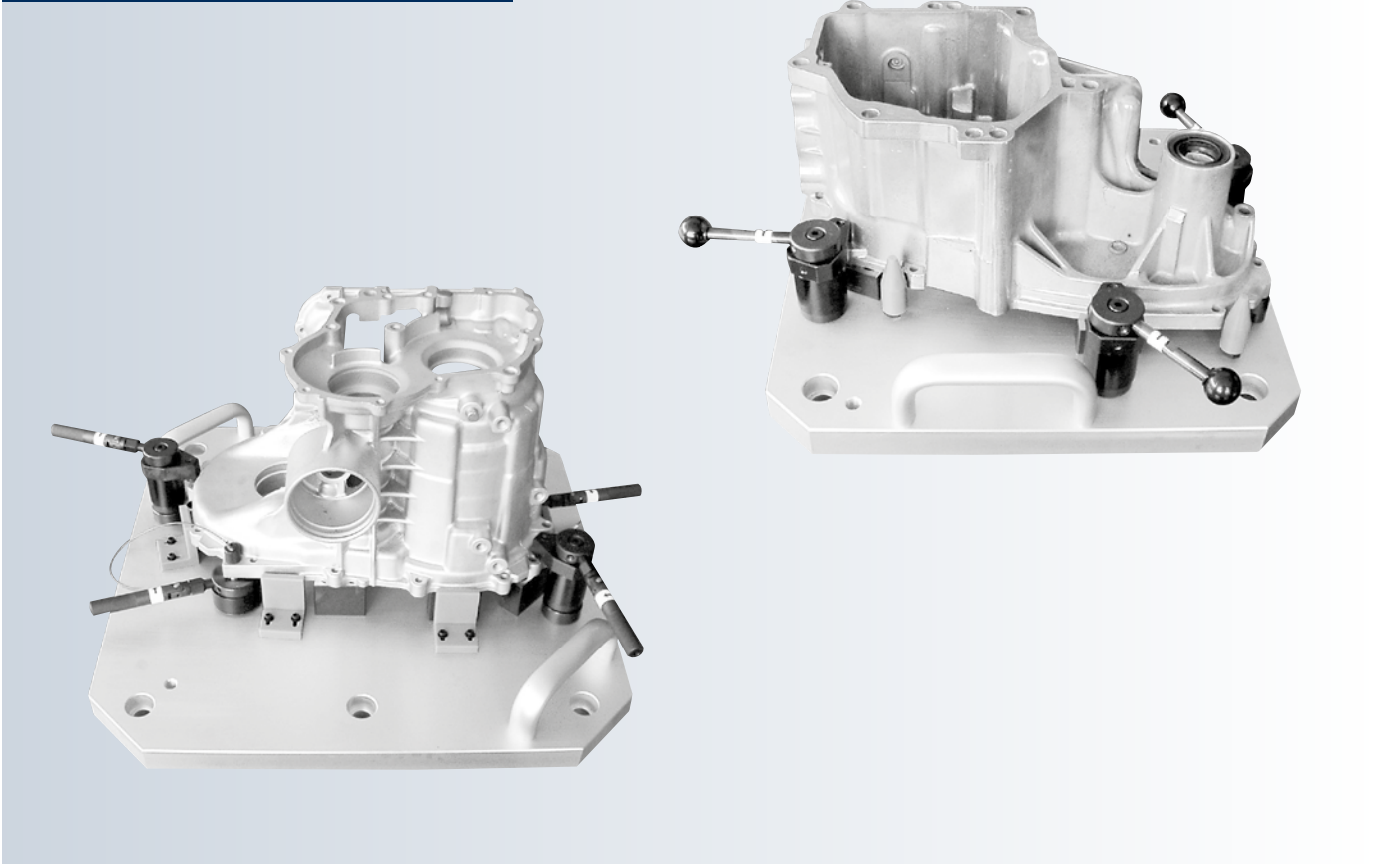

Actual Applications of Side Clamps

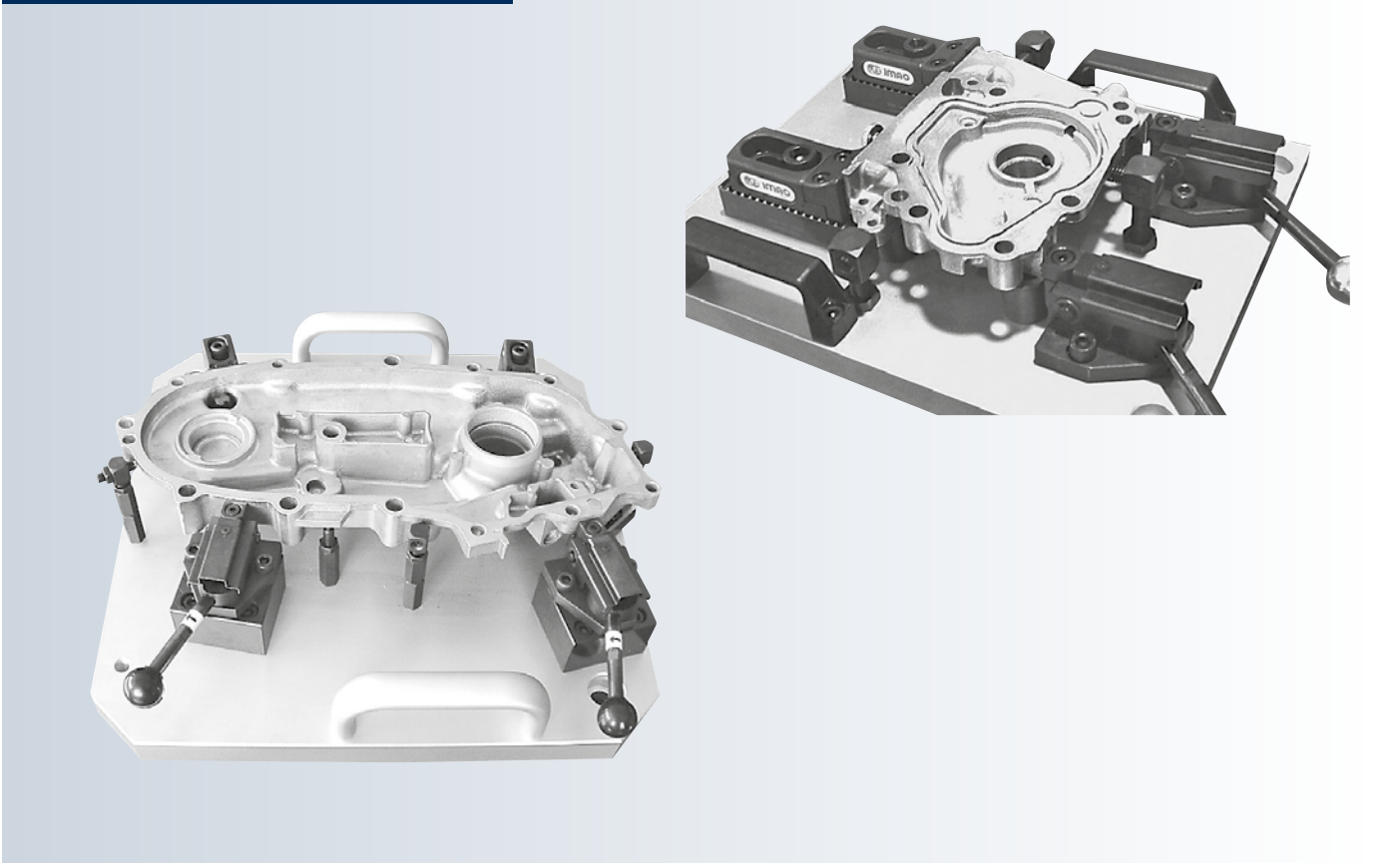

CP710

SPRING-LOADED WORK LOCATORS

NEW



Standard

Accurate

Body	
Material	S45C steel
Finitura	Black oxide
Heat Treat	Quenched and tempered
Locating Pin	
Material	SK4 steel
Heat Treat	Quenched and tempered

Mounting Hole Dimensions

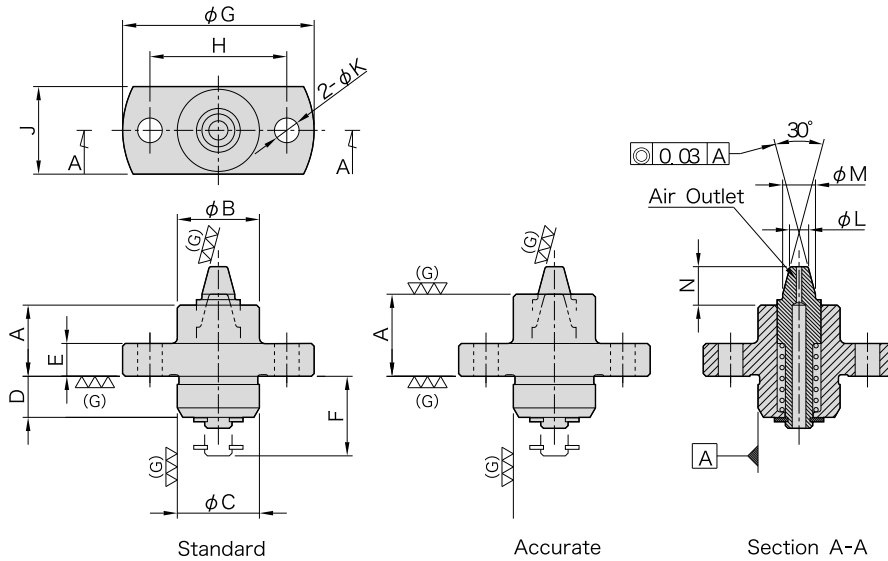
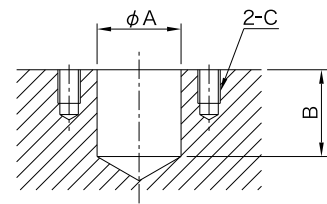
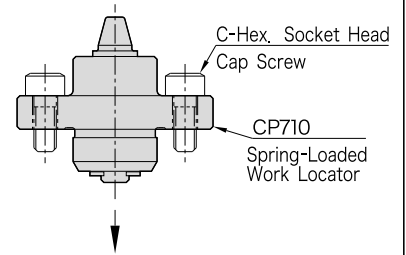

Standard

Accurate

Section A-A

Series	A (H7)	B	C
51991521 51991522	15 (H7-effective depth: 8)	16	M4x0.7
51991523 51991524	20 (H7-effective depth: 10)	21	M4x0.7
51991527 51991528			

Standard

Part Number	A	B	C (g6)	D	E	F	G	H	J	K	L	M
51991521	13	15	15	7.5	6	15	35	25	16	4.5	3.5	6
51991522											4.5	7
51991523	18	20	20	10	8	20	40	30	22	4.5	5.5	9
51991524											7.5	11

Part Number	N	Locating Hole Dia. *)	Support Capacity (N)	Weight (g)
51991521	7.4	$\phi 3.8$ to $\phi 5.2$	6.4 to 19.3	45
51991522		$\phi 4.8$ to $\phi 6.2$		45
51991523	9.3	$\phi 5.8$ to $\phi 8.2$	5.5 to 20.5	95
51991524		$\phi 7.8$ to $\phi 10.2$		95

Accurate

Part Number	A ($\pm 0,01$)	B	C (g6)	D	E	F	G	H	J	K	L	M
51991525	15	15	15	7.5	6	15	35	25	16	4.5	3.5	6
51991526											4.5	7
51991527	20	20	20	10	8	20	40	30	22	4.5	5.5	9
51991528											7.5	11

Part Number	N	Locating Hole Dia. *)	Support Capacity (N)	Weight (g)
51991525	5.4	$\phi 3.8$ to $\phi 5.2$	6.4 to 19.3	50
51991526		$\phi 4.8$ to $\phi 6.2$		50
51991527	7.3	$\phi 5.8$ to $\phi 8.2$	5.5 to 20.5	100
51991528		$\phi 7.8$ to $\phi 10.2$		100

*) Within these diameter limits, locating holes can be chamfered up to 1mm x 1mm.

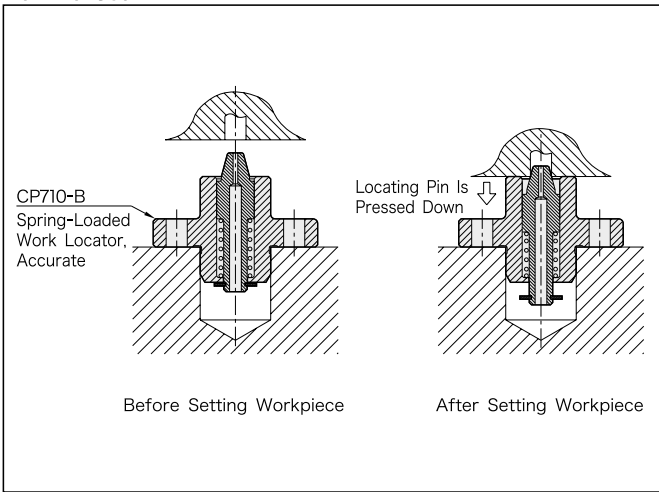

When the workpiece is set, the tapered pin is pressed down to locate it. The accurate style allows vertically as well as horizontally positioning the workpiece with accuracy.

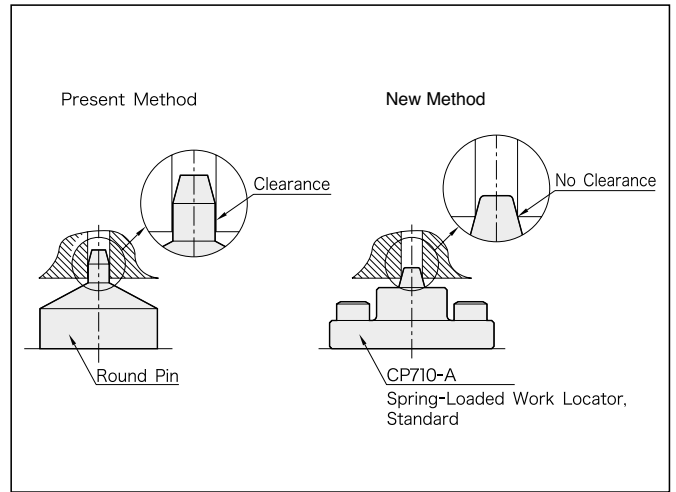

Use of tapered pin allows secure locating with no clearance between the locating hole and the tapered pin.

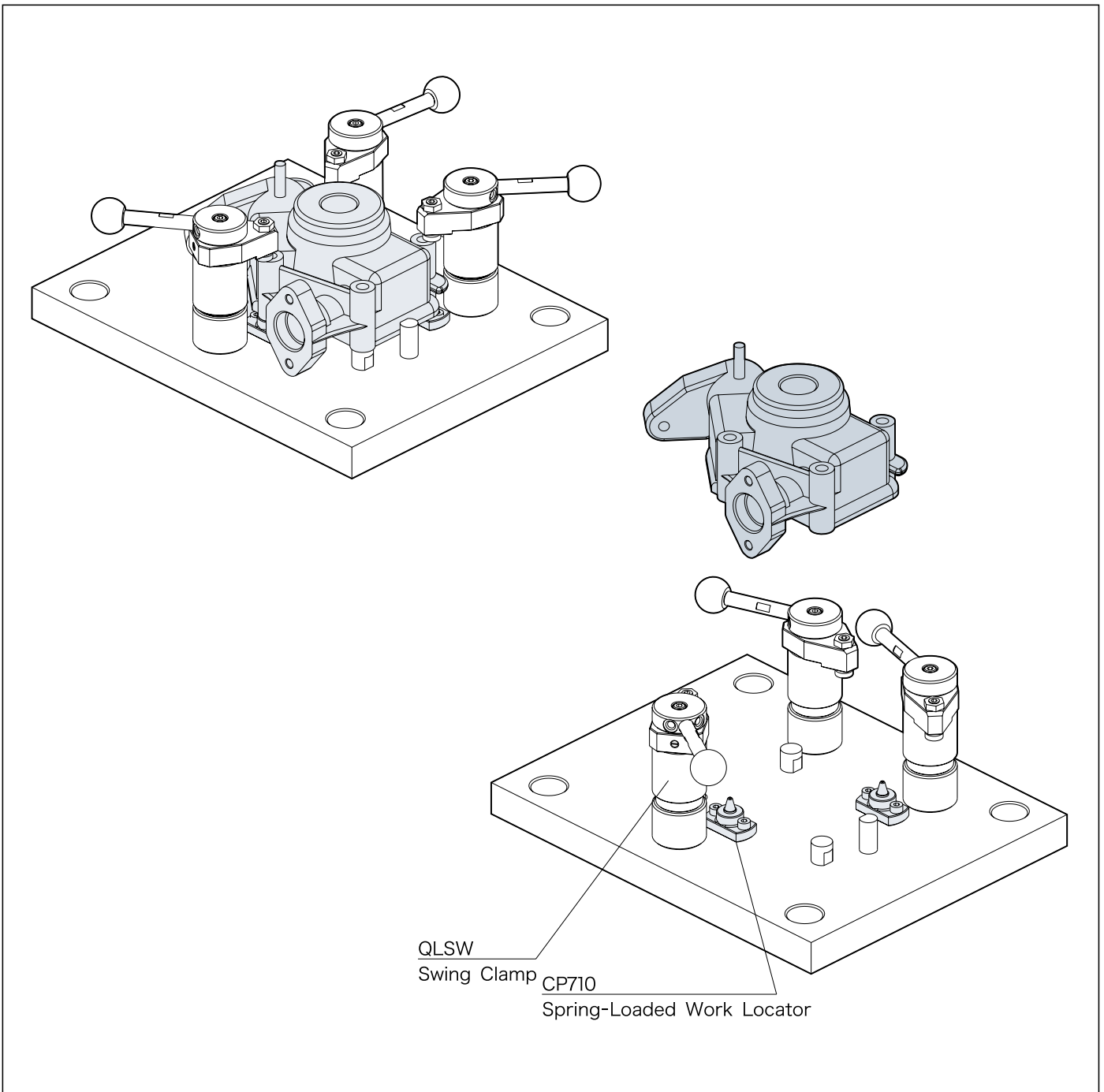

Note: In clamping, hold down the workpiece by hand to avoid lift that can be generated by spring force.

NEW



Body	
Material	S45C steel
Finish	Black oxide
Heat Treat	Quenched and tempered
Piston	
Material	SCM440 steel
Finish	Black oxide
Heat Treat	Quenched and tempered
Handle	
Material	SC45 steel
Finish	Black oxide
Ball Knob	
Material	ABS resin
Color	Black

How To Use

Present Method

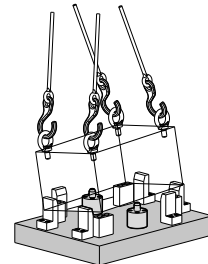

Galling and damage caused



Our Method

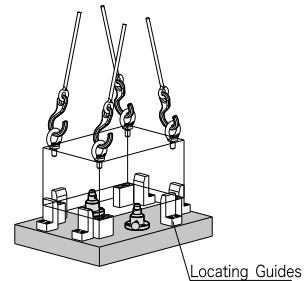

No galling caused

The locating pin gets projected only after the workpiece is set on supports. This allows loading and unloading the workpiece smoothly, with no galling. Get the locating pin projected to locate the workpiece after it is roughly positioned with the help of locating guides.

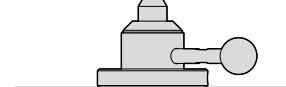

Retracted Mode

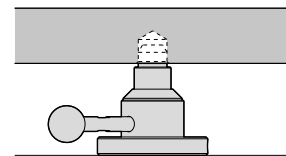

Projected Mode

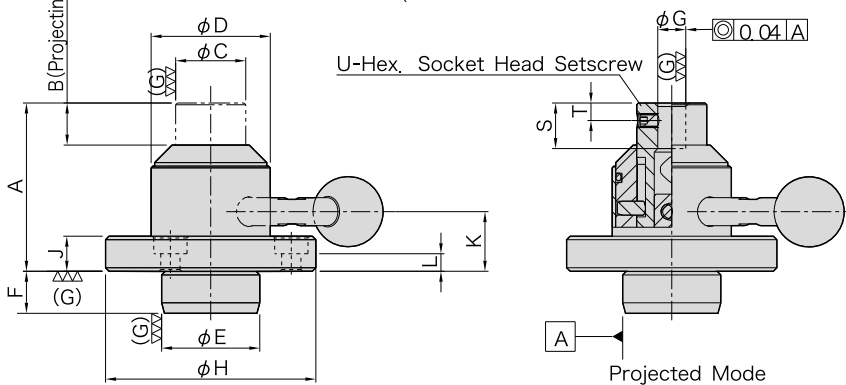
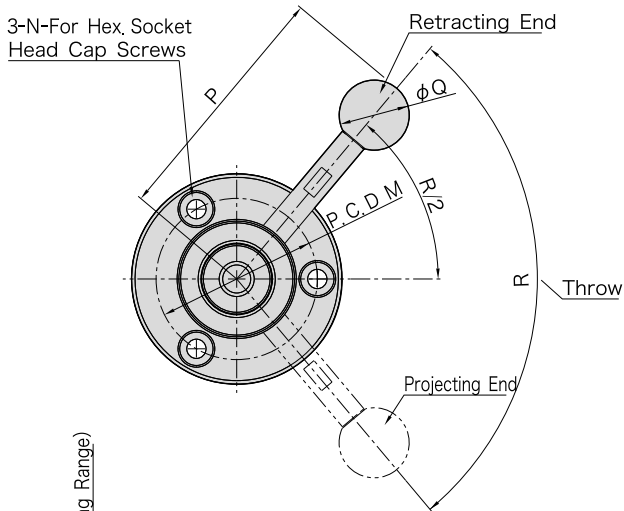

Part Number	A	B	C	D	E (g6)	F	G (G7)	H	J	K	L	M (P.C.D)	N	P
51991529	48	12	20	34	28	12	8	60	10	17	5	46	M5	71
51991530	61	15	30	48	42	14	12	80	13	23	7	63	M6	94

Part Number	Q	R	S	T	U	Allowable Operating Load (N)*	Max. Workpiece Weight (kg)**	Weight (kg)
51991529	20	100	13	5	M4x0.7-5L	150	250	0.42
51991530	25	90	15	8	M6x1 -8L	200	300	1.04

*) Allowable load to operate the handle

**) Max. weight that allows the locating pin to project and provide workpiece centering

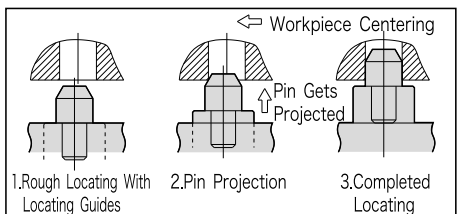

NEW



Body	
Material	S45C steel
Finish	Black oxide
Heat Treat	Quenched and tempered
Pistone	
Material	SC45 steel
Finish	Black oxide

How To Use

Extended Application

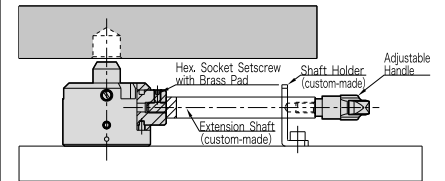

With an extension shaft and a shaft holder prepared separately, the handle control can be easily done even when small space is available under the workpiece.

Locating-Pin Mounting

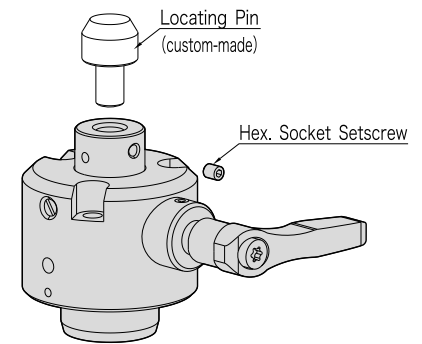

Projected Mode

A locating pin can easily be mounted by using a hex socket setscrew when the piston is fully projected (locating pins must be prepared separately).

Locating-Pin Head Dimensions

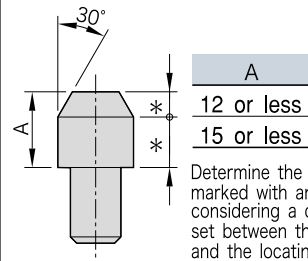

A
12 or less
15 or less

Determine the dimensions marked with an asterisk considering a clearance set between the workpiece and the locating guides. When the taper angle is determined to be smaller than 30° (recommended), set the clearance smaller.

3-L-For Hex. Socket Head Cap Screws

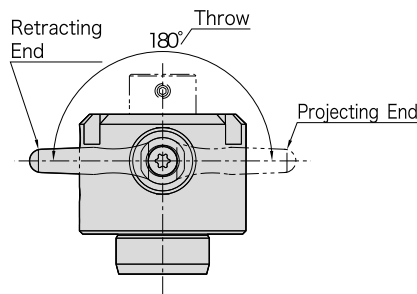
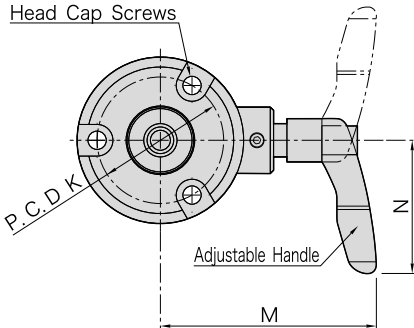

The handle position can be changed freely, clockwise or counterclockwise.

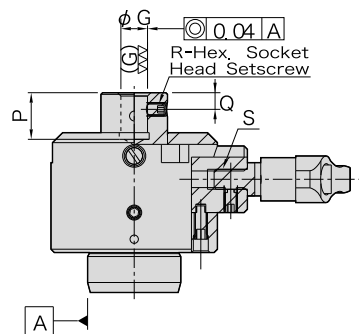
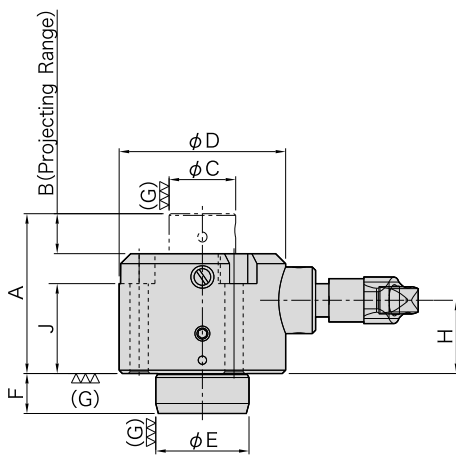

Projected Mode

Part Number	A	B	C	D	E (g6)	F	G (G7)	H	J	K (P, C, D)	L	M	N	P
51991533	48	12	20	50	28	12	8	22	27	38	M5	65	40	14
51991534	61	15	30	65	42	14	12	26	31	52	M6	87.5	65	16

Part Number	Q	R	S	Adjustable Handles	Allowable Operating Load(N*)	Max. Workpiece Weight(kg)**	Weight (kg)
51991533	5	M4x0.7-5L	M6x1 12 deep	FKR6X10-BR	170	250	0.59
51991534	6	M5x0.8-8L	M8x1.25 17 deep	FKR8X15-BR	210	300	1.31

*) Allowable load to operate the handle

**)Max. weight that allows the locating pin to project and provide workpiece centering

Features

- Can support heavy workpieces made from steel or cast iron
- No tools needed
- Different locating pins can be mounted depending on workpiece's locating holes.
- The piston stays locked when it is fully projected or retracted until the handle is operated again.

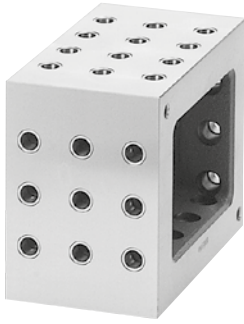

[Body]

Material:FC300 cast iron
Annealed
Precision ground

[Alignment Bushing]
Material:SUJ2 steel
Heat treated

[Threaded Insert]
Material:S45C steel
Heat treated

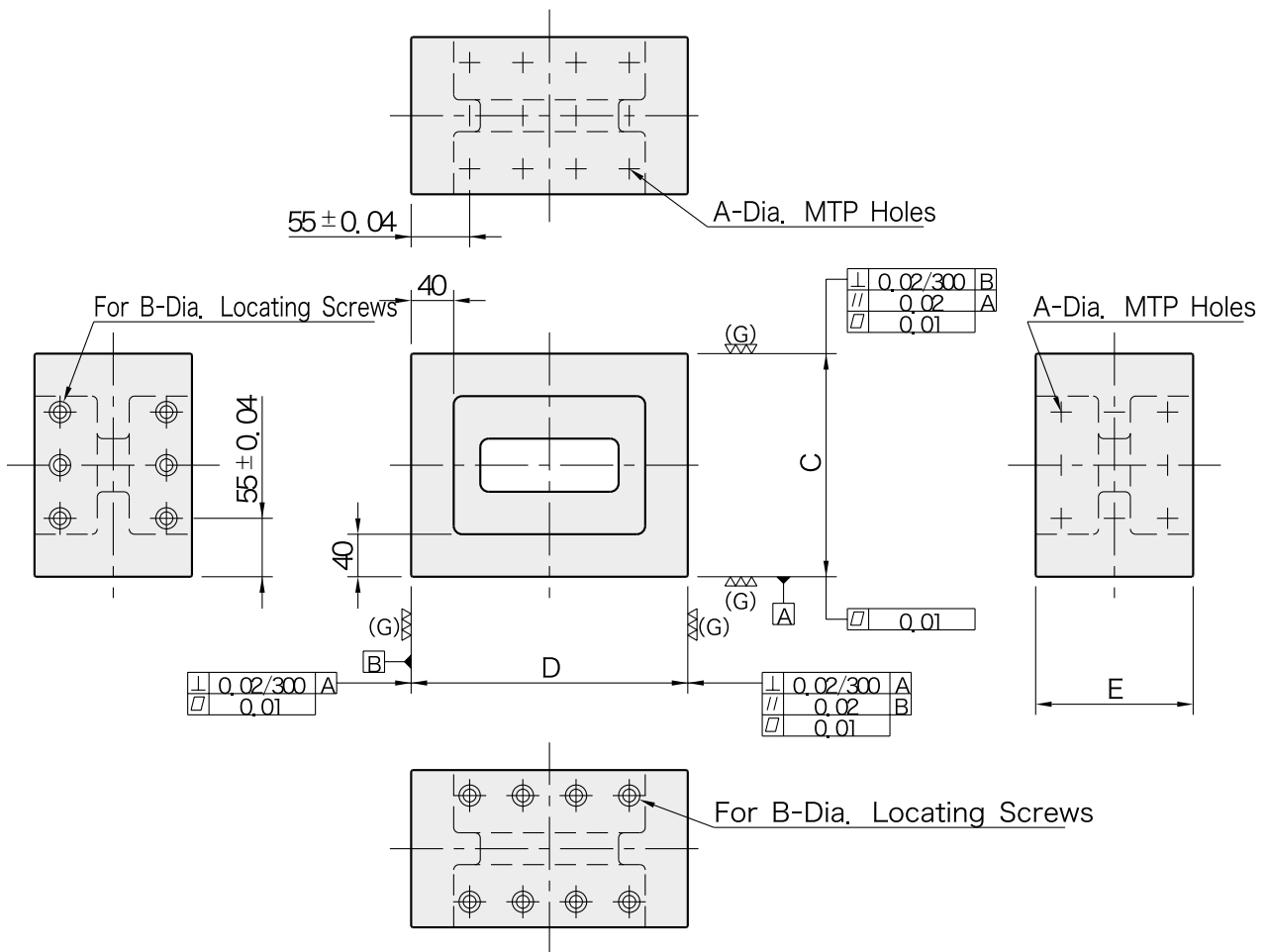

Part Number	A		B (F7)	C (± 0.02)		D (± 0.02)	E	No. of MTP Holes	No. of Mounting Holes	Proper Locating Screws Cod.	Weight (kg)
	(F7)	(Thread)		(± 0.02)	(± 0.02)						
51991535	12	M12x1.75	12	160	210	148	15	10	51991863	26	
51991536				210	260						37
51991537	16	M16x2	16	160	210	148	15	10	51991865	25	
51991538				210	260						36

- MTP-hole protection plugs and eye bolts are included.
- Locate on a tooling plate or block using Locating Screws.
- MTP holes spacing : 50 ± 0.02 mm



[Body]
 Material:FC300 cast iron
 Annealed
 Precision ground

[Alignment Bushing]
 Material:SUJ2 steel
 Heat treated

[Threaded Insert]
 Material:S45C steel
 Heat treated

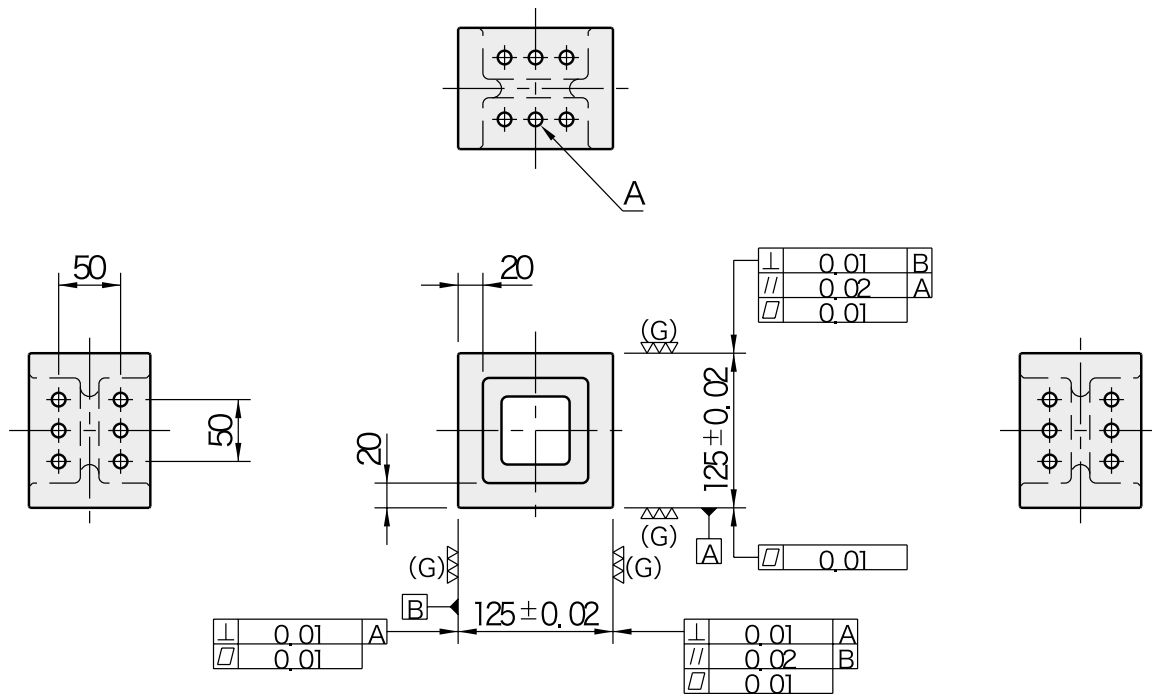

For C-Dia. Locating Pins For B- Socket-Head Cap Screws

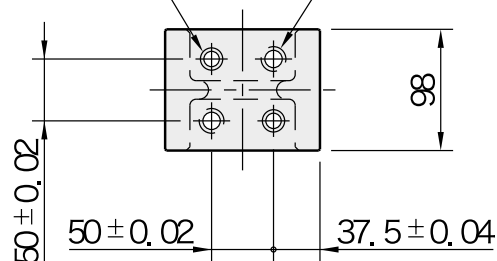

Part Number	A	B	C (F7)	Weight (kg)
51991539	M12x1.75	M12	12	6.3
51991540	M16x2	M16	16	6.2

•Locate on a tooling plate or block using a round pin and a diamond pin.

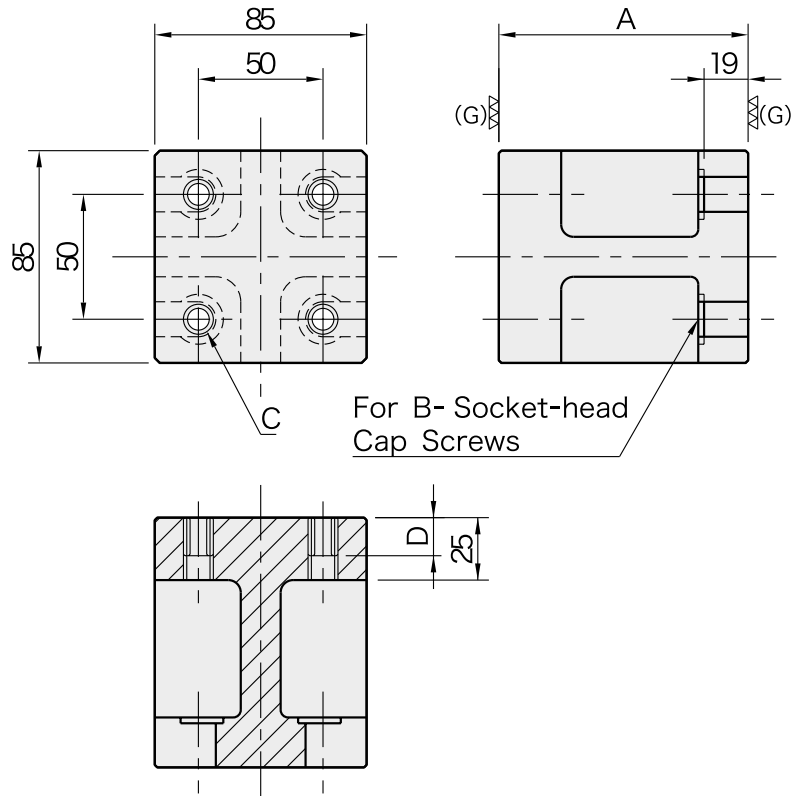
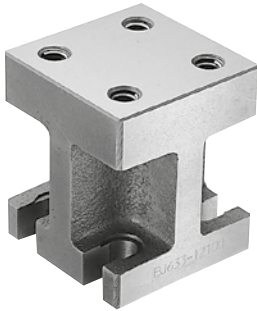

【Body】

- Material : FC300 cast iron
- Annealed
- Precision ground

【Threaded Insert】

- Material : S45C steel
- Heat treated

Part Number	A (±0.01)	B	C	D	Weight (kg)
51991543	100	M16	M16×2	16	3.2
51991544	125				3.8

■ How To Use

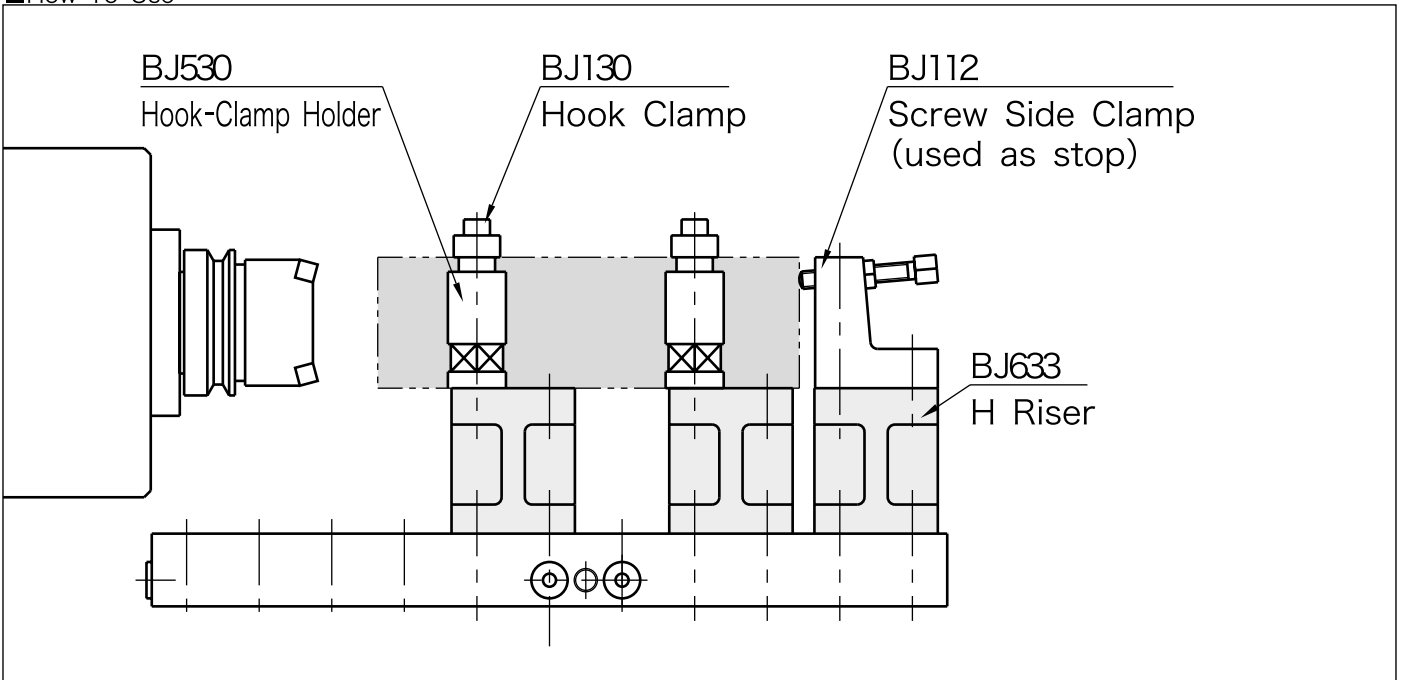

Use to raise a workpiece or components, parallel to a tooling plate.

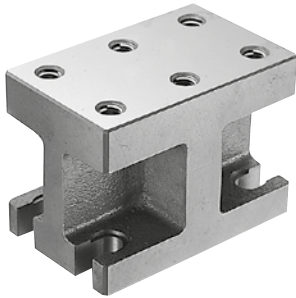

[Body]

- Material : FC300 cast iron
- Annealed
- Precision ground

[Threaded Insert]

- Material : S45C steel
- Heat treated

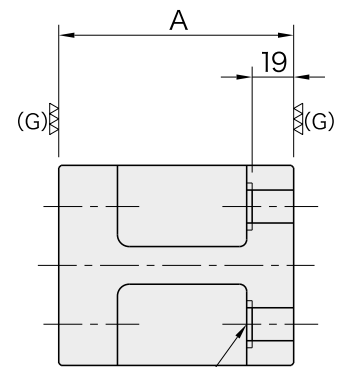
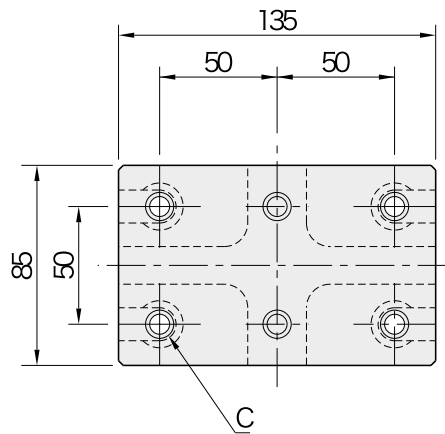

For B- Socket-head
Cap Screws

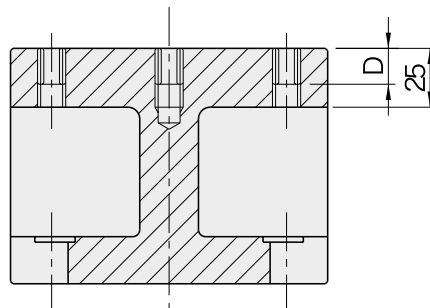

Part Number	A (±0.01)	B	C	D	Weight (kg)
51991547	100	M16	M16×2	16	5.1
51991548	125				5.8

BJ440(Mini)

V BLOCKS

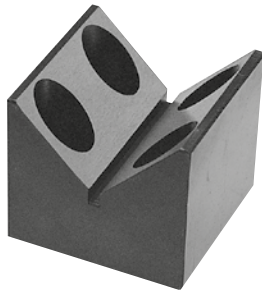

- Material : S45C steel
- Heat treated
- Black oxide finish
- Precision ground

BJ440-08032

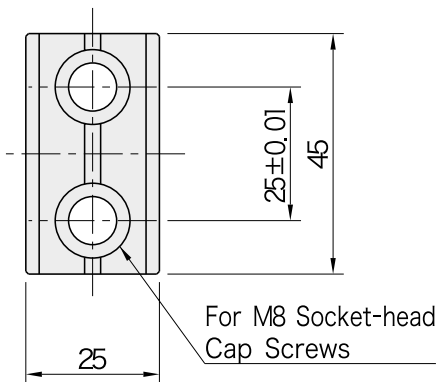

BJ440-08040

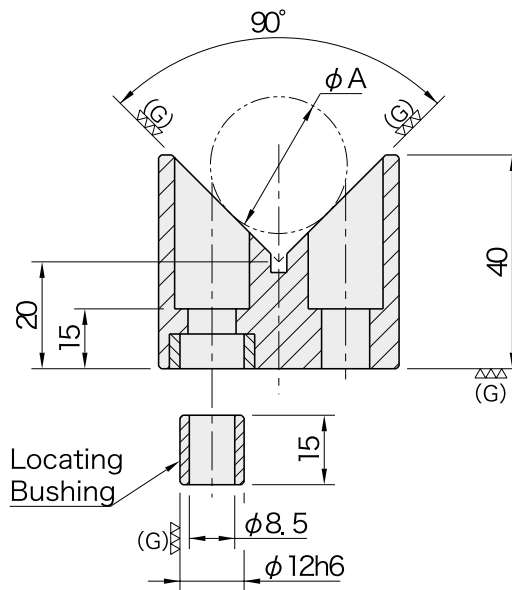
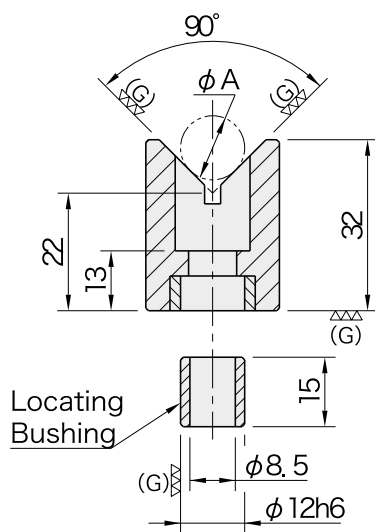
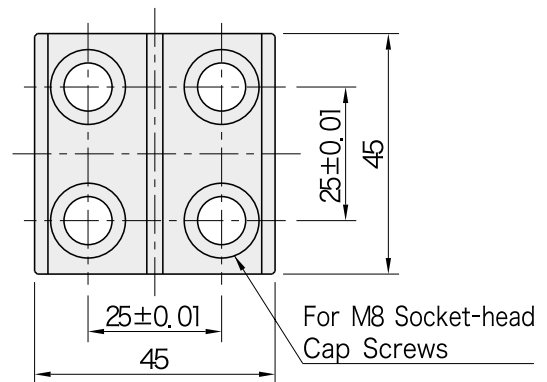

Part Number	A		Weight (g)
	min.	max.	
51991549	10	25	200
51991550	15	50	370

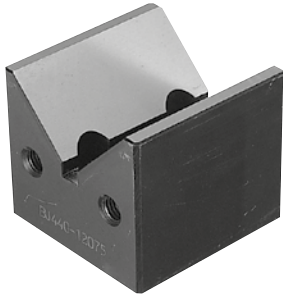

- Material : S45C steel
- Heat treated
- Black oxide finish
- Precision ground

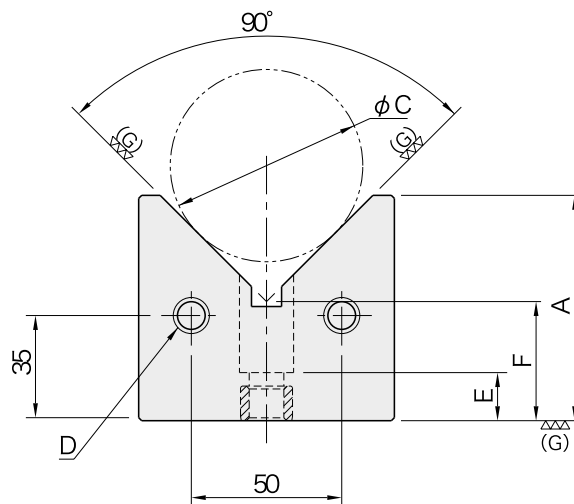
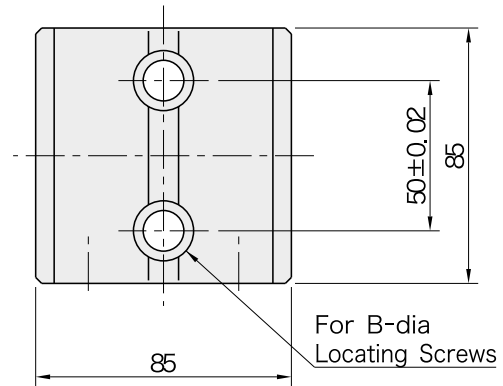

Part Number	A	B (F7)	C		D	E	F
			Min.	Max.			
51991551	63	12	15	80	M12×1.75 30 deep	22	34.72
51991552	75			100			39.65
51991553	63	16	15	80	M16×2 35 deep	25	34.72
51991554	75			100			39.65

Part Number	Proper Locating Screws Cod.	Weight (kg)
51991551	51991862	2.9
51991552		3.3
51991553	51991864	2.9
51991554		3.3

BJ770

METAL PROTECTION PLUGS



51991556



51991555

Part Number	Thread	Weight (g)
51991555	M12	15
51991556	M16	20
57290020	D16/M12	18

- Replacement protection plugs.
- Use to keep chips and dirt out of unused MTP holes.

BJ701

HIGH PRECISION LOCATING SCREW



Material:SCM435 steel
Heat treated
Black oxide finish
Precision ground

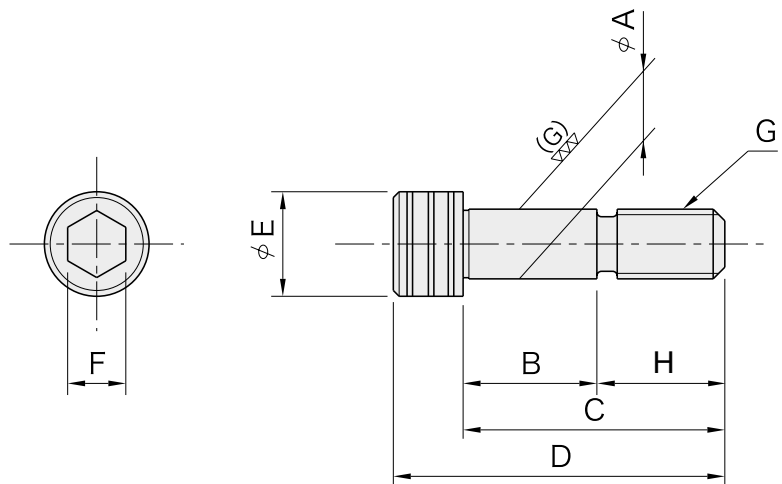

Part Number	A*	B	C	D	E	F	G	H	Weight (g)
51 99 18 66	12	23	45	57	18	10	M12x1,75	22	52
51 99 18 62		33	55	67					59
51 99 18 63		43	65	77					68
51 99 18 65	16	30	55	71	24	14	M16x2	25	120
51 99 18 64		40	65	81					134

* - 0,005
- 0,013

CENTERING PIN

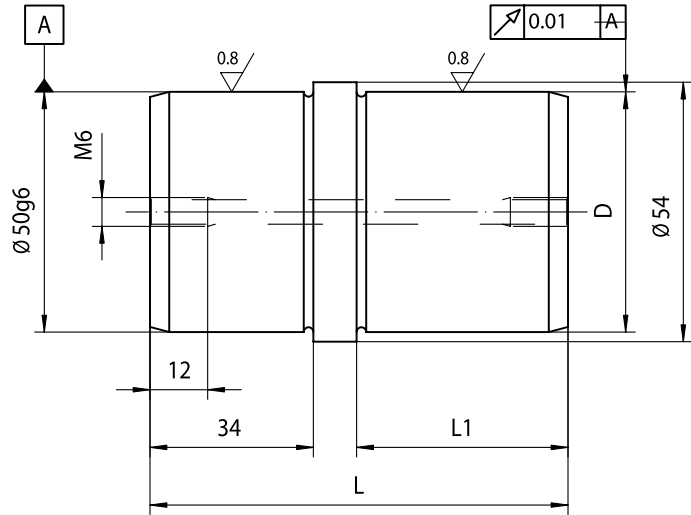

Part Number	D _{g6}	L	L1	Weight (Kg)
57001051	25	77	34	0.81
57001052	40	87	44	1.12
57001053	50	87	44	1.36

CENTERING PIN FOR ALIGNING HOLE

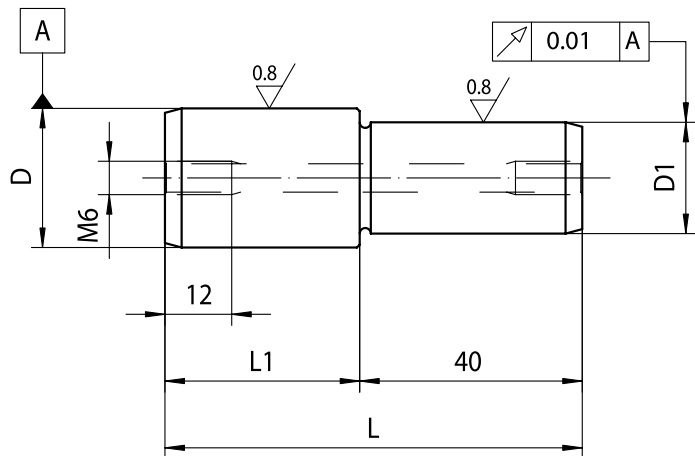

Part Number	D _{g6}	D _{1g6}	L	L1	Weight (Kg)
57001061	25	20	75	35	0.23
57001062	30	20	85	45	0.34
57001063	30	35	85	45	0.40

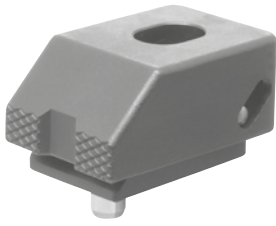

Material: S45C steel
 Finish : Black oxide
 Heat Treated

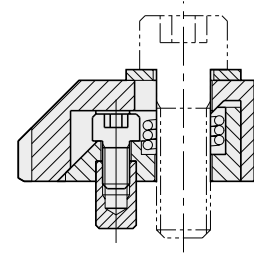
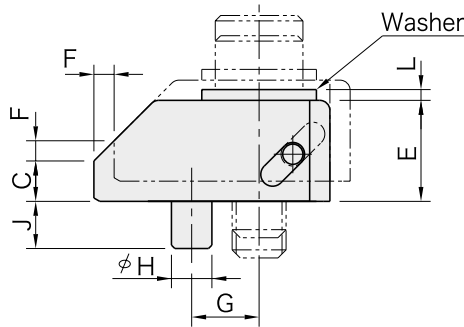
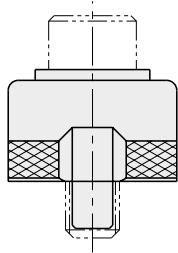
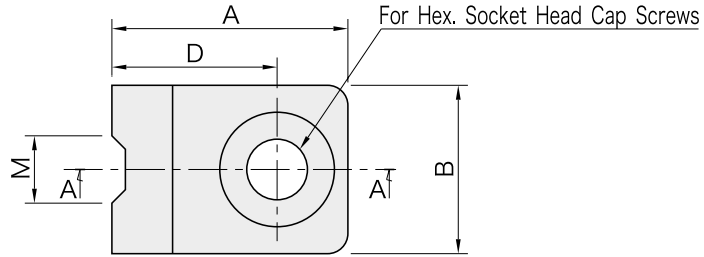

Section A-A

Part Number	A	B	C	D	E	F	G	H (h7)	J	K	L	M	Clamping Force (N)	Allowable Screw Torque (N·m)	Weight (g)
51991557	35	25	6	24.5	15	3	10	6	7	M 8	1.6	10	7,000	25	100
51991558	43	30	8	29	19	4	12	6	7	M10	2	11	8,500	50	185
51991559	54	35	9	37	23	5	16	8	10	M12	2.3	12	20,000	90	320
51991560	65	40	10	45	25	6	20	10	10	M16	3.2	14	40,000	200	520

How To Use and Install

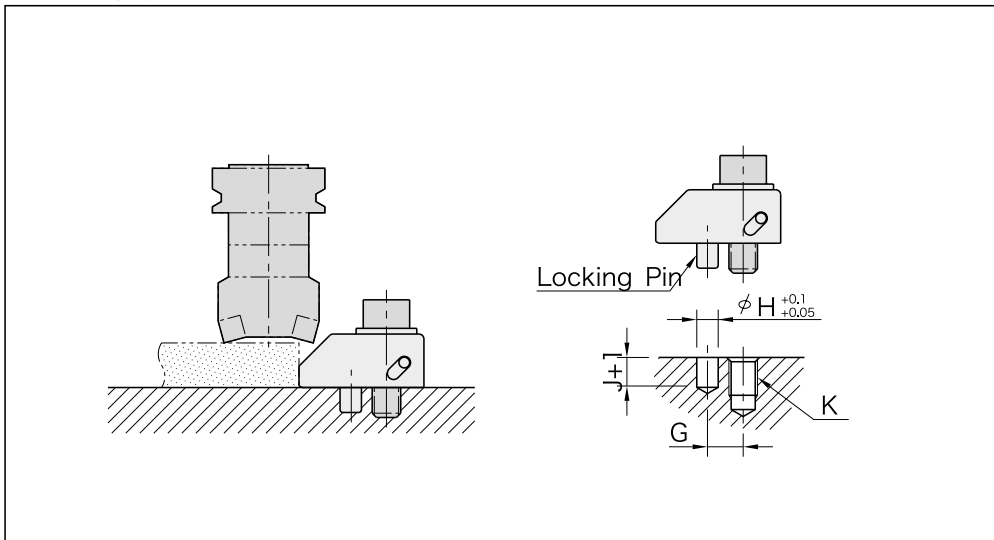

- Drill a cap-screw hole and a locking-pin hole as specified.
- One flat washer is included.

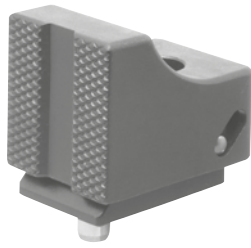

Material: S45C steel
 Finish : Black oxide
 Heat Treated

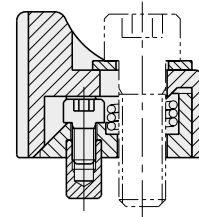
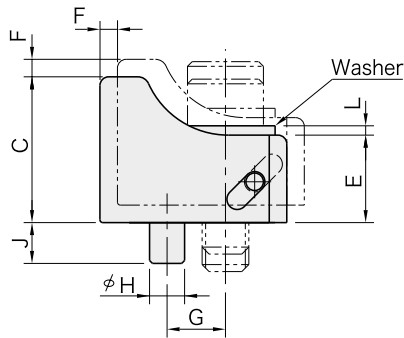
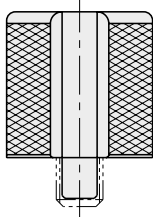
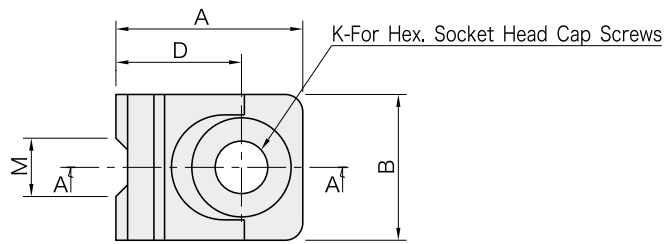

Section A-A

Part Number	A	B	C	D	E	F	G	H (h7)	J	K	L	M	Clamping Force (N)	Allowable Screw Torque (N·m)	Weight (g)
51991561	32	25	25	21.5	15	3	10	6	7	M 8	1.6	10	7,000	25	115
51991562	40	30	32	26	19	4	12	6	7	M10	2	11	8,500	50	225
51991563	50	35	38	33	23	5	16	8	10	M12	2.3	12	20,000	90	390
51991564	60	40	45	40	25	6	20	10	10	M16	3.2	14	40,000	200	640

How To Use and Install

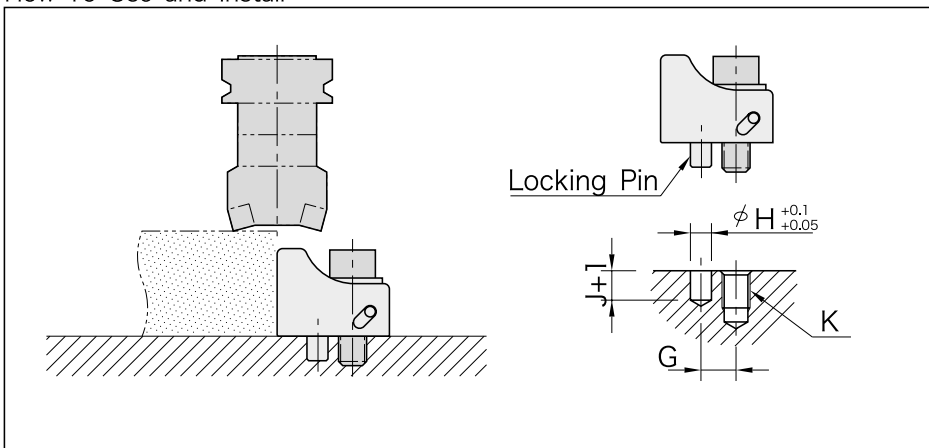

- Drill a cap-screw hole and a locking-pin hole as specified.
- One flat washer is included.

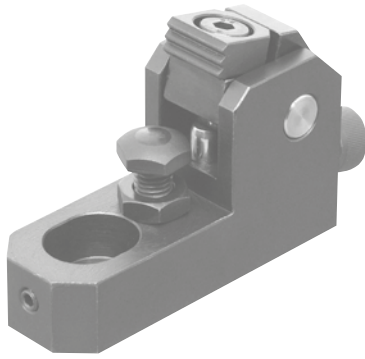

[Body]

Material: S45C steel
 Finish : Black oxide
 Heat Treated

[Arm]

Material: S45C steel
 Finish : Black oxide

[Jaw]

Material: SKH51 steel
 Finish : Black oxide
 Heat Treated

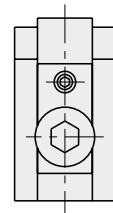
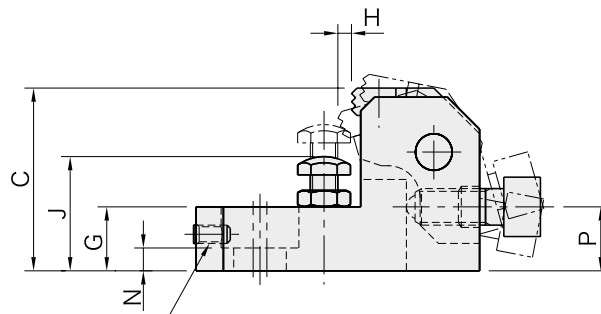
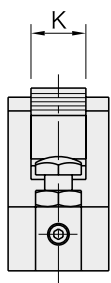
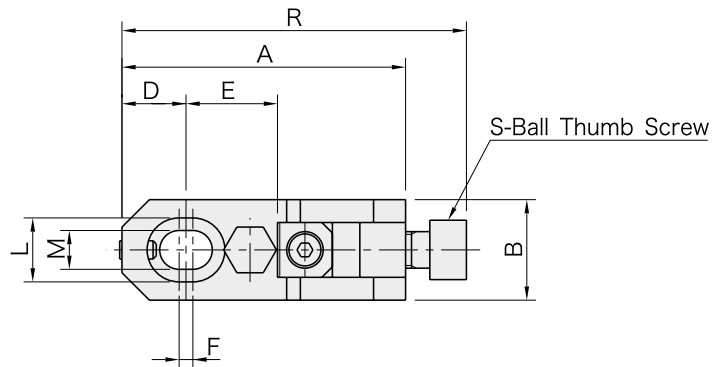

T-Hex. Socket-Head Setscrew

Part Number	A	B	C	D	E	F	G	H	J	K	L	M
51991565	62	22	40	14	20	3	14	3	25 to 32	12	14	8.5
51991566	78	25	50	18	25	4	18	3.7	32 to 40	16	17.5	11
51991567	93	32	60	21	30	5	21	4.5	40 to 48	20	20	13
51991568	124	38	80	28	40	6	27	6	48 to 63	25	26	17

Part Number	N	P	R	S	T	Clamping Force (N)	Allowable Screw Torque (N·m)	Weight (kg)
51991565	5	14	75.5	M 8x1.25-20L	M4x0.7-8L	6.000	15	0.23
51991566	7	17.5	95	M10x1.5-25L	M5x0.8-10L	10.000	30	0.41
51991567	8	21	113	M12x1.75-30L	M6x1-12L	17.000	65	0.75
51991568	10	28	151	M16x2-40L	M8x1.25-16L	25.000	130	1.57

Spare jaws

Cod.	
51992035	See page 14.95
51992038	
51992042	
51992044	

How To Use and Install

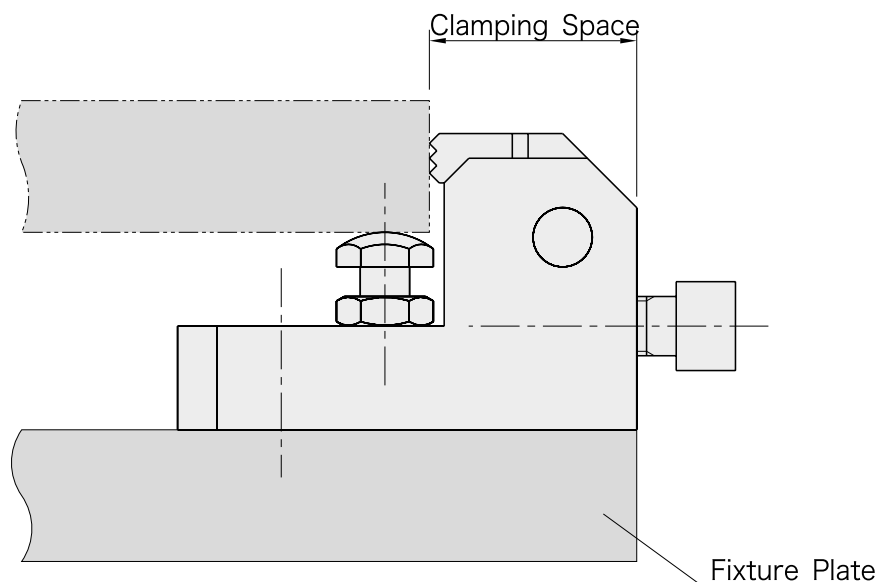

Smaller clamping space allows clamping a larger workpiece.

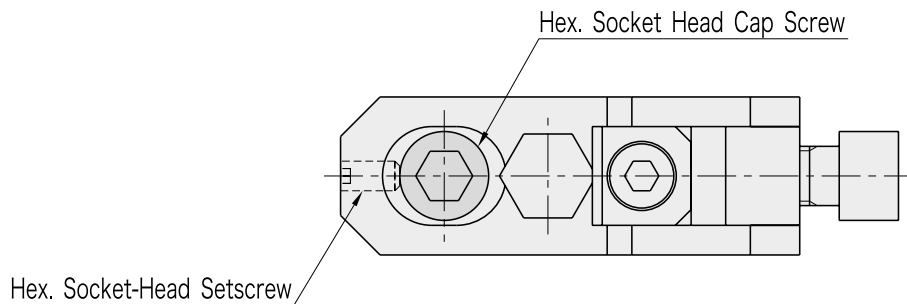

The hex. socket-head setscrew works to prevent the clamp from sliding back if screwed in until it contacts the cap screw.

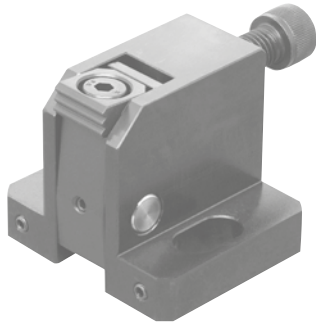

[Body]

Material: S45C steel
Finish : Black oxide

[Arm]

Material: S45C steel
Finish : Black oxide
Heat Treated

[Jaw]

Material: SKH51 steel
Finish : Black oxide
Heat Treated

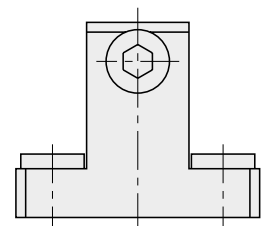
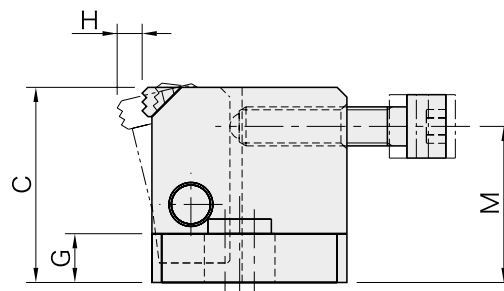
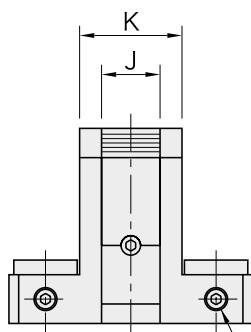
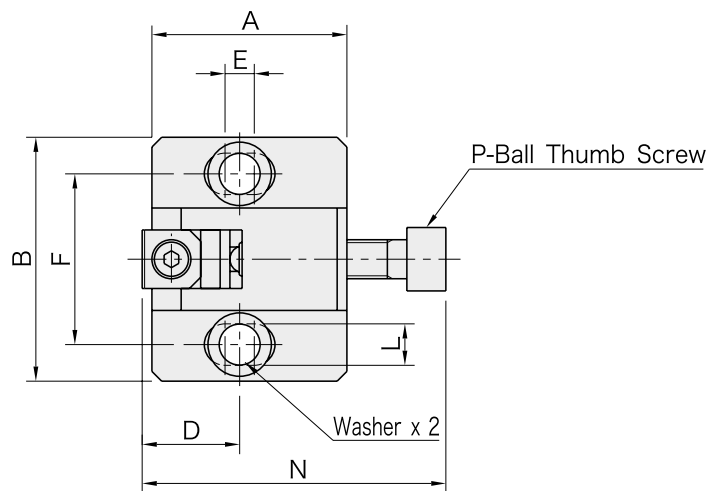

Part Number	A	B	C	D	E	F	G	H	J	K	L
51991569	40	50	40	20	6	35	10	5.3	12	21	8.5
51991570	50	65	50	25	8	45	12	7.1	16	27	11
51991571	60	70	60	30	10	50	15	8	20	31	13
51991572	80	90	80	40	15	65	20	10.2	25	39	17

Part Number	M	N	P	R	Clamping Force (N)	Allowable Screw Torque (N·m)	Weight (kg)
51991569	32	62.5	M 8x1.25-35L	M4x0.7-10L	11.000	25	0.33
51991570	40	74	M10x1.5-40L	M4x0.7-12L	18.000	50	0.66
51991571	48	91	M12x1.75-50L	M5x0.8-15L	25.000	90	1.06
51991572	64	115	M16x2-60L	M6x1-20L	46.000	200	2.38

Spare jaws

Cod.	
51992035	
51992038	See page 14.95
51992042	
51992044	

How To Install

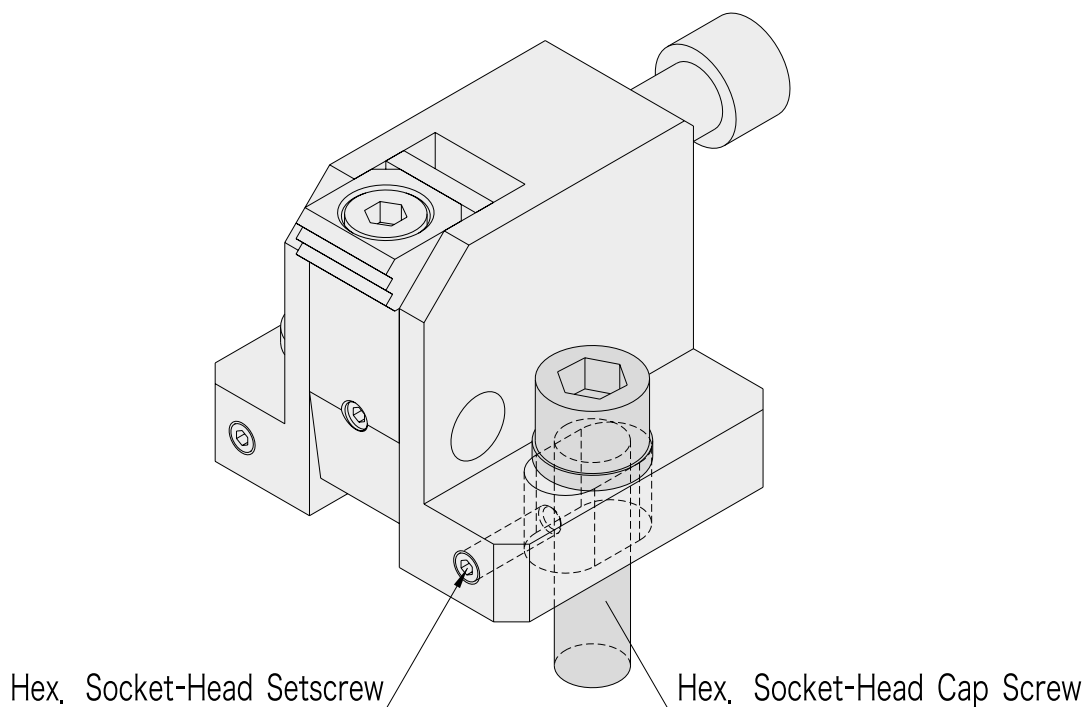

The hex. socket-head setscrew works to prevent the clamp from sliding back if screwed in until it contacts the cap screw.

•Two flat washers are included.

CP102

WIDE-JAW SIDE CLAMPS

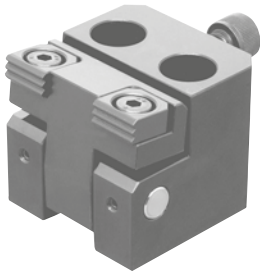

[Body]
 Material: S45C steel
 Finish : Black oxide

[Arm]
 Material: S45C steel
 Finish : Black oxide
 Heat Treated

[Jaw]
 Material: SKH51 steel
 Finish : Black oxide
 Heat Treated

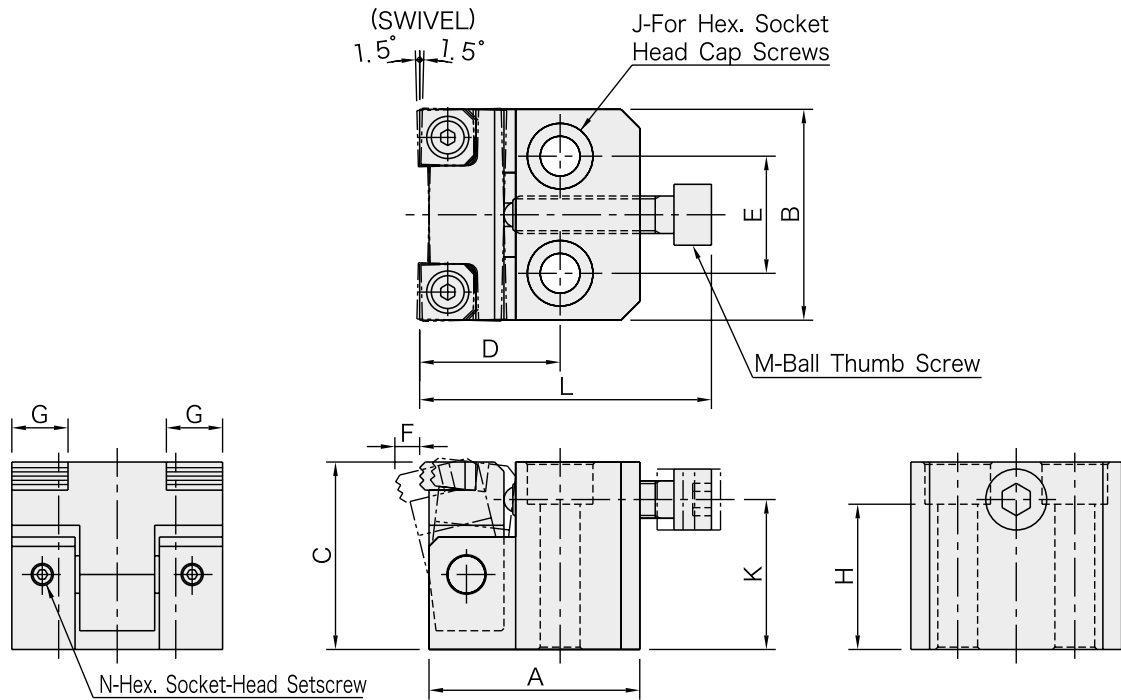

Part Number	A	B	C	D	E	F	G	H	J	K	L	M	N
51991573	45	45	40	30	25	5.3	12	31	M 8	32	62.5	M 8x1.25-35L	M4x0.7-4L
51991574	55	55	50	40	30	7.1	16	39	M10	40	74	M10x1.5 -40L	M4x0.7-4L
51991575	65	65	60	45	35	8	20	47	M12	48	91	M12x1.75-50L	M5x0.8-5L

Part Number	Clamping Force (N)	Allowable Screw Torque (N·m)	Weight (kg)
51991573	11.000	25	0.55
51991574	18.000	50	1
51991575	25.000	90	1.69

How To Use

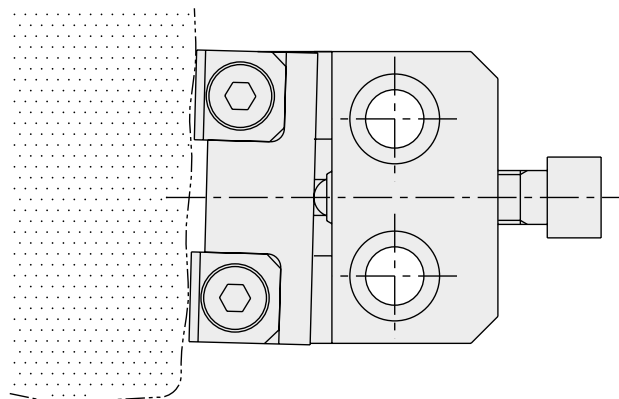

The jaw swivels to fit an unmachined surface of the workpiece.



Serrated

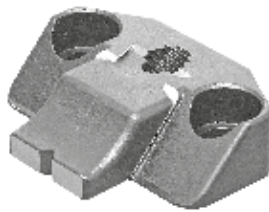

Ground

[Body]

Material: SCM440 steel
 Finish : Black oxide
 Heat Treated

[Jaw]

Material: SCM440 steel
 Finish : Black oxide
 Heat treated on edge

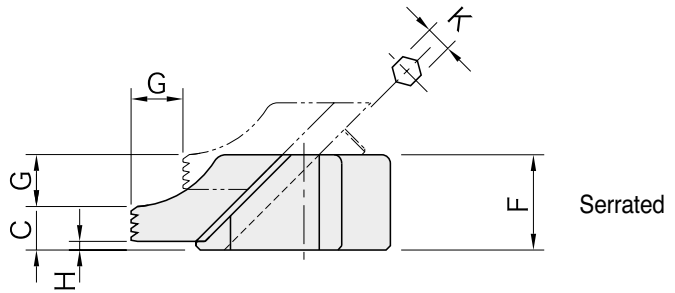
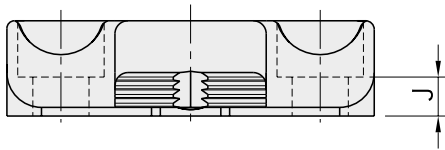
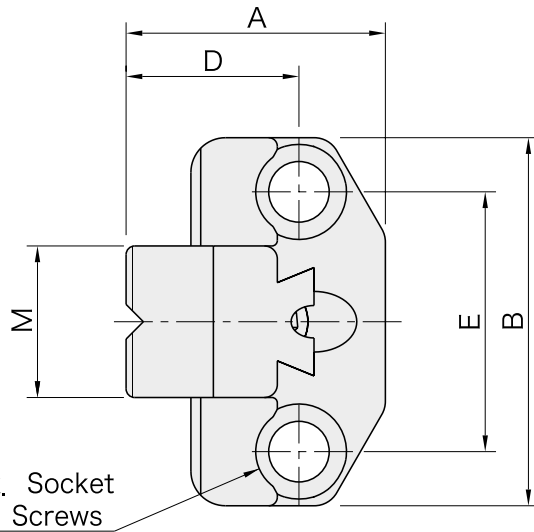

Serrated

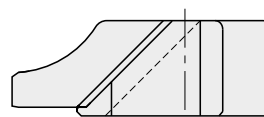
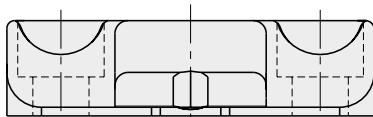

Ground

Serrated		A	B	C	D	E	F	G	H	J	K	L	M	Clamping Force (N)	Allowable Screw Torque (N·m)	Weight (g)
Part Number																
51991576		39.5	65	7.5	25	45	16	7	1.5	7	4	M 8	25	4.000	8	160
51991578		60	85	10	40	60	22	12	2	9	6	M12	35	9.000	26	450
51991580		77	100	14	50	70	30	14	2	13	8	M16	40	17.000	60	900

Ground		A	B	C	D	E	F	G	H	J	K	L	M	Clamping Force (N)	Allowable Screw Torque (N·m)	Weight (g)
Part Number																
51991577		39.5	65	7.5	25	45	16	7	1.5	7	4	M 8	25	4.000	8	160
51991579		60	85	10	40	60	22	12	2	9	6	M12	35	9.000	26	450
51991581		77	100	14	50	70	30	14	2	13	8	M16	40	17.000	60	900

CP105

SIDE CLAMPS

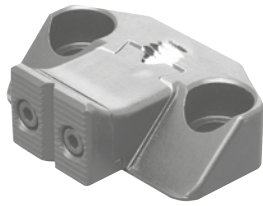

Serrated

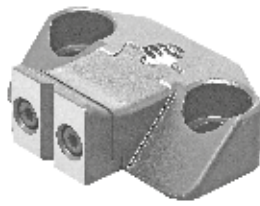

Ground

[Body & Jaw Carrier]
 Material: SCM440 steel
 Finish : Black oxide
 Heat treated

[Jaw]
 Material: SCM440 steel
 Finish : Black oxide
 Heat treated on edge

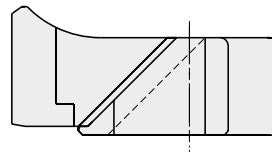
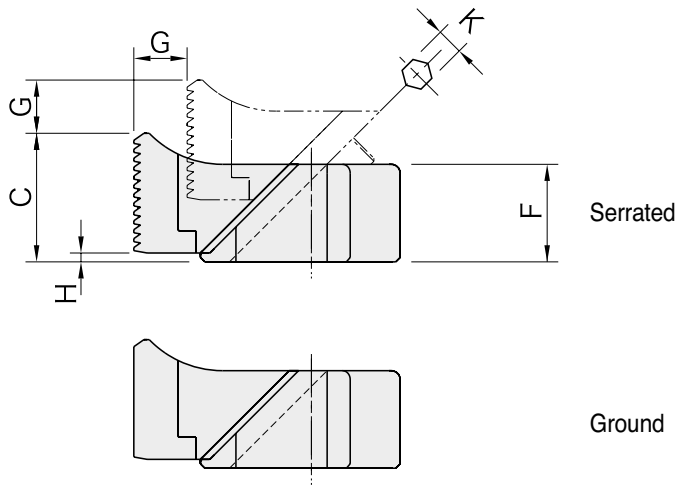
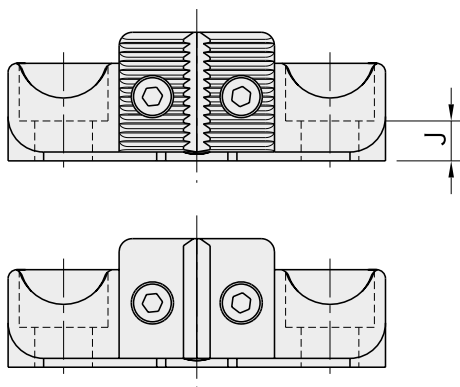
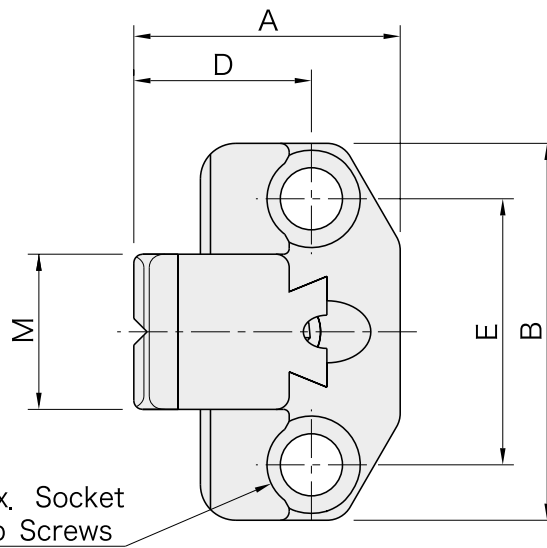

Serrated	A	B	C	D	E	F	G	H	J	K	L	M	Clamping Force (N)	Allowable Screw Torque (N·m)	Weight (g)
51991582	39.5	65	19.5	25	45	16	7	1.5	7	4	M 8	25	4.000	8	180
51991584	60	85	29	40	60	22	12	2	9	6	M12	35	9.000	26	500
51991586	77	100	38	50	70	30	14	2	13	8	M16	40	17.000	60	1.010

Ground	A	B	C	D	E	F	G	H	J	K	L	M	Clamping Force (N)	Allowable Screw Torque (N·m)	Weight (g)
51991583	39.5	65	19.5	25	45	16	7	1.5	7	4	M 8	25	4.000	8	180
51991585	60	85	29	40	60	22	12	2	9	6	M12	35	9.000	26	500
51991587	77	100	38	50	70	30	14	2	13	8	M16	40	17.000	60	1.010



Serrated



Ground

[Body]
 Material:FCM440 steel
 Heat treated
 Black oxide finish

[Sliding Nose]
 Material:SCM440 steel
 Heat treated (on edge)
 Black oxide finish
 Precision ground or serrated

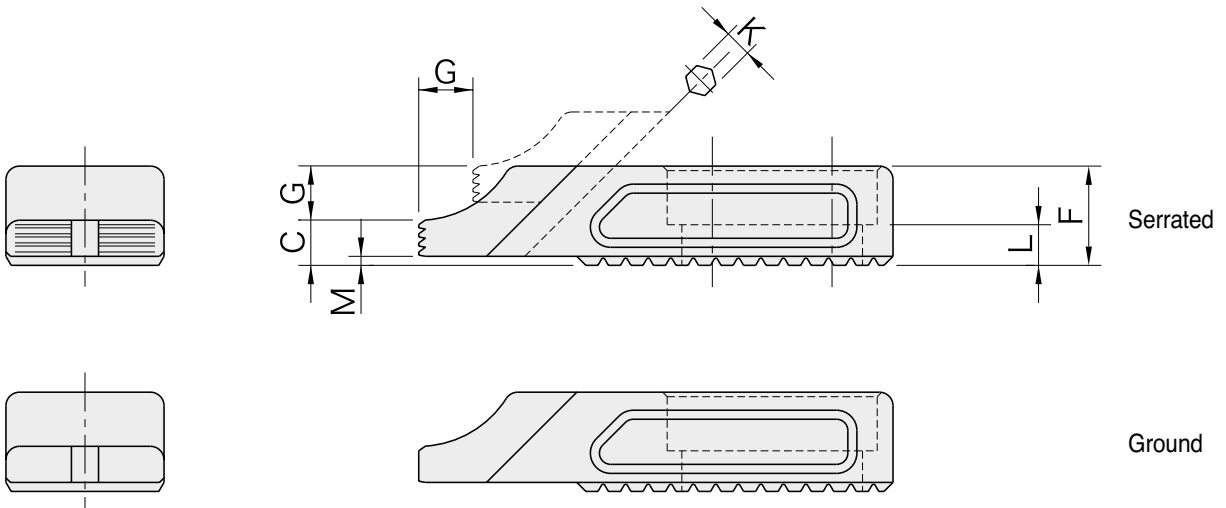
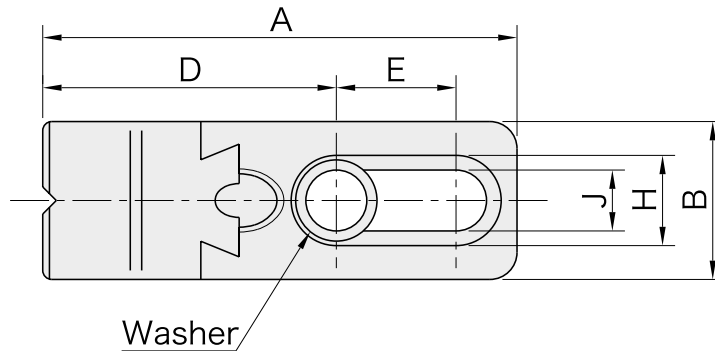

Serrated	A	B	C	D	E	F	G	H	J	K	L	M	Weight (g)
51991588	72	25	7.5	45.5	16.5	16	7	14	8.5	4	7	1.5	150
51991590	105	35	10	65	26.5	22	12	20	13	6	9	2	400
51991592	137	40	14	89.5	30	30	14	26	17	8	13	2	830

Ground	A	B	C	D	E	F	G	H	J	K	L	M	Weight (g)
51991589	72	25	7.5	45.5	16.5	16	7	14	8.5	4	7	1.5	150
51991591	105	35	10	65	26.5	22	12	20	13	6	9	2	400
51991593	137	40	14	89.5	30	30	14	26	17	8	13	2	830

Part Number	When Used Singularly		When Used with Slide Stop		Weight (g)
	Clamping Force (N)	Allowable Screw Torque (N·m)	Clamping Force (N)	Allowable Screw Torque (N·m)	
51991588	3,600	6.5	4,000	8	150
51991589					
51991590	7,400	19	10,400	26	400
51991591					
51991592	11,700	32	24,000	60	830
51991593					

BJ102

ADJUSTABLE SIDE CLAMPS



Serrated



Ground

[Body & Jaw Carrier]
 Material:FCM440 steel
 Heat treated
 Black oxide finish

[Jaw]
 Material:SCM440 steel
 Heat treated
 Black oxide finish
 Precision ground or serrated

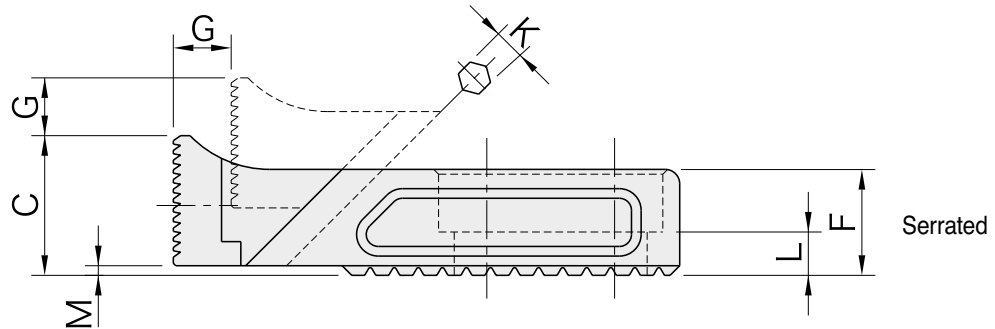
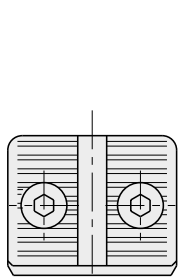
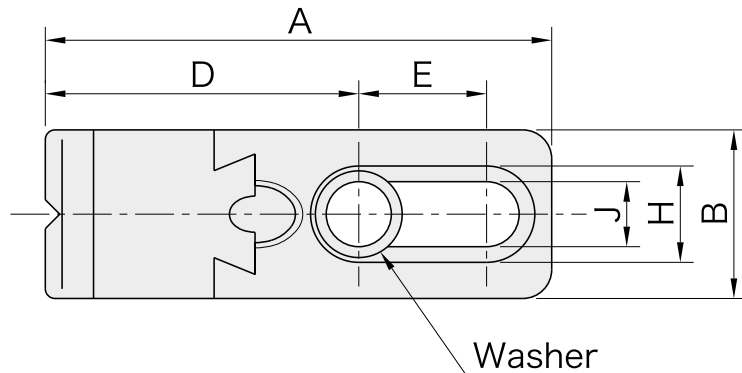

Serrated

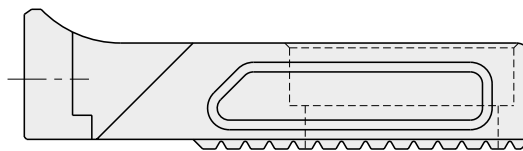
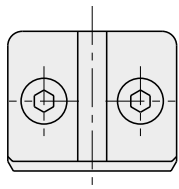

Ground

Serrated Part Number	A	B	C	D	E	F	G	H	J	K	L	M	Weight (g)
51991594	72	25	19.5	45.5	16.5	16	7	14	8.5	4	7	1.5	160
51991596	105	35	29	65	26.5	22	12	20	13	6	9	2	440
51991598	137	40	38	89.5	30	30	14	26	17	8	13	2	920

Ground Part Number	A	B	C	D	E	F	G	H	J	K	L	M	Weight (g)
51991595	72	25	19.5	45.5	16.5	16	7	14	8.5	4	7	1.5	160
51991597	105	35	29	65	26.5	22	12	20	13	6	9	2	440
51991599	137	40	38	89.5	30	30	14	26	17	8	13	2	920

Part Number	Clamping Force (N) *	Allowable Screw Torque (N·m) *	Weight (g)
51991594	3,600	6,5	160
51991595			
51991596	7,400	19	440
51991597			
51991598	11,700	32	920
51991599			

Note *) The stated values are effective when used singularly (not mounted on a serrated adaptor).



Serrated

【Body】

- Material : FCM440 steel
- Black oxide finish

【Jaw】

- Material : SCM440 steel
- Heat treated
- Black oxide finish
- Precision serrated

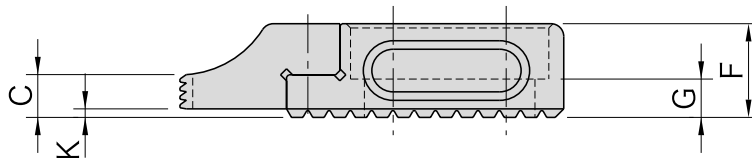
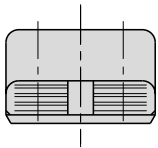
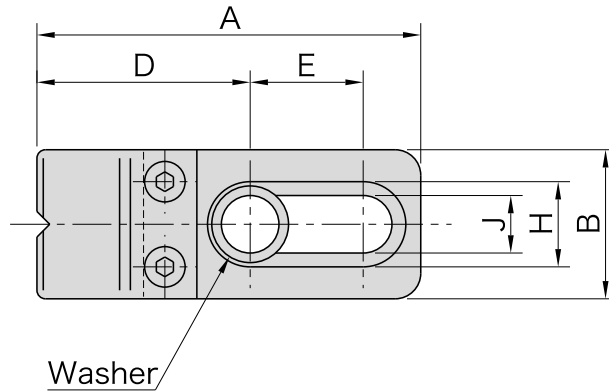

Serrated

Part Number	A	B	C	D	E	F	G	H	J	K	Weight (g)
51991600	60	25	7.5	33.5	16.5	16	7	14	8.5	1.5	120
51991601	90	35	10	50	26.5	22	9	20	13	2	330
51991602	115	40	14	67.5	30	30	13	26	17	2	660

Note *) The stated values are effective when used singularly (not mounted on a serrated adaptor).

· Stop that mounts on a BJ500. Rack Block to prevent backslide.

BJ202

ADJUSTABLE SIDE STOPS



Serrated

【Body】

- Material : FCM440 steel
- Black oxide finish

【Jaw】

- Material : SCM440 steel
- Heat treated
- Black oxide finish
- Precision serrated

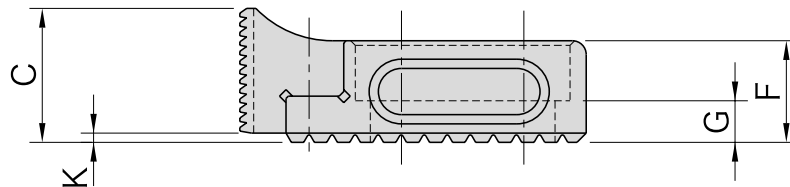
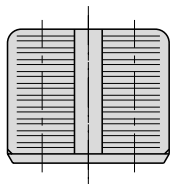
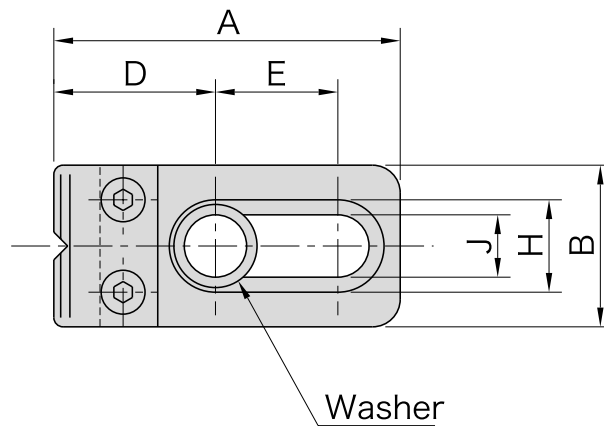

Serrated

Part Number	A	B	C	D	E	F	G	H	J	K	Weight (g)
51991603	50	25	19.5	23.5	16.5	16	7	14	8.5	1.5	100
51991604	75	35	29	35	26.5	22	9	20	13	2	310
51991605	95	40	38	47.5	30	30	13	26	17	2	625

Note *) The stated values are effective when used singularly (not mounted on a serrated adaptor).

· Stop that mounts on a BJ500, Rack Block to prevent backslide.

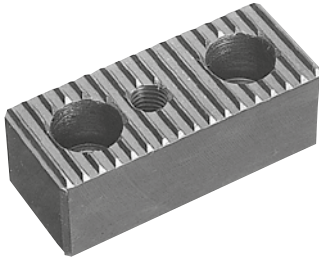

■Material : S45C steel
 ■Black oxide finish

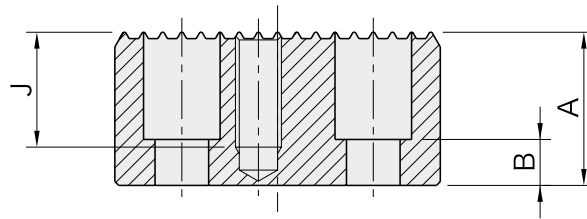
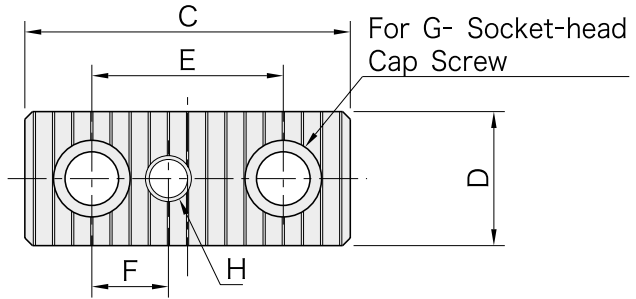

Part Number	A	B	C	D	E	F	G	H	J	Weight (kg)	
51991606	16	7	50	25	25	12.5	M 8	M 8×1.25	Through	0.13	
51991607	20	9								0.17	
51991608	25	13								0.21	
51991609	32	20								0.27	
51991610	40	28								0.33	
51991611	50	38								0.42	
51991612	20	5	85	35	50	20	M12	M12×1.75	Through	0.34	
51991613	25	10								0.45	
51991614	32	12								0.57	
51991615	40									30	0.71
51991616	50									35	0.9
51991617	25	6								90	40
51991618	32	13	0.62								
51991619	40	15	0.78								
51991620	50		30	0.98							
51991621	63		35	1.24							

■How To Use

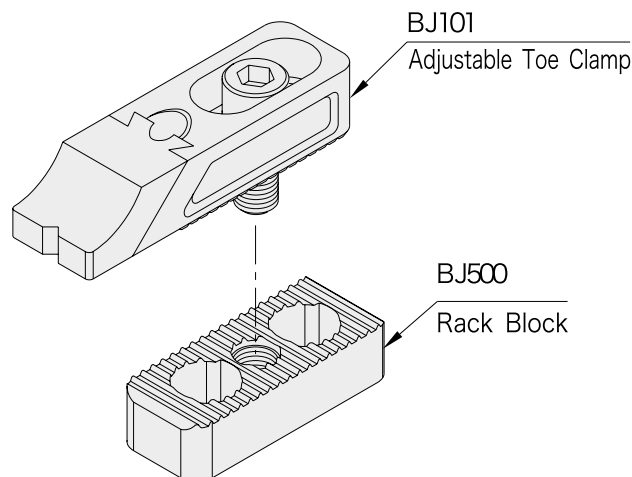

Serrated riser that prevents BJ101/BJ102 clamps and BJ201/BJ202 stops from slipping backward.

CP110

BLOCK PUSH CLAMPS

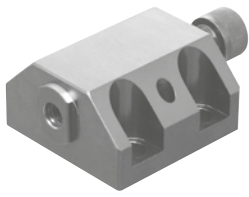

CP110
(Cap Screw Style)

[Body]
Material: S45C steel
Finish : Black oxide

[Piston]
Material: S45C steel
Finish : Black oxide
Heat Treated

[Knurled Knob]
Material: S45C steel
Finish : Black oxide

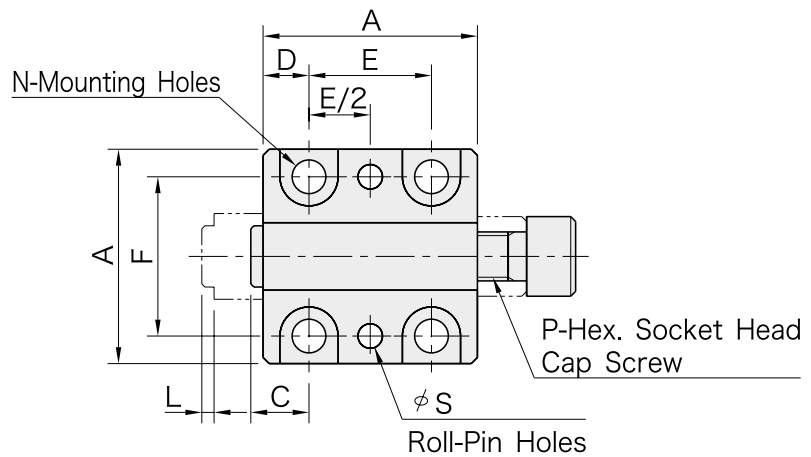

CP110
(Cap Screw Style)

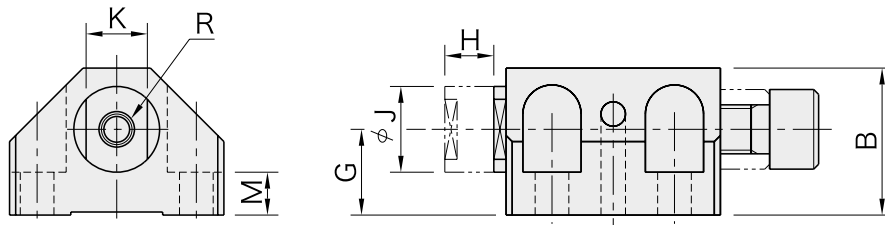

Part Number	A	B	C	D	E	F	G	H	J	K ($\frac{+0.1}{-0.3}$)	L	M	N	P	R	S	T	U
51991622	35	24	9.5	7.5	20	26	14	8	14	10	2	7	M 5	M 8x1.25	M 5x0.8 8 Prof.	4	24	14
51991623	45	29	12	10	25	35	16	10	18	12	2	8	M 6	M10x1.5	M 6x1 10 Prof.	4	24	14
51991624	55	31	15	12.5	30	40	18	12	20	14	2.5	8	M 8	M12x1.75	M 8x1.25 12 Prof.	6	30	17
51991625	70	37	18	15	40	50	20	16	25	19	3	8	M10	M16x2	M10x1.5 15 Prof.	8	36	20

Cap Screw Style			
Part Number	Clamping Force (N)	Allowable Screw Torque (N·m)	Weight (g)
51991622	6 200	10	160
51991623	11 000	22	340
51991624	20 000	48	540
51991625	37 000	121	1 050

How To Use

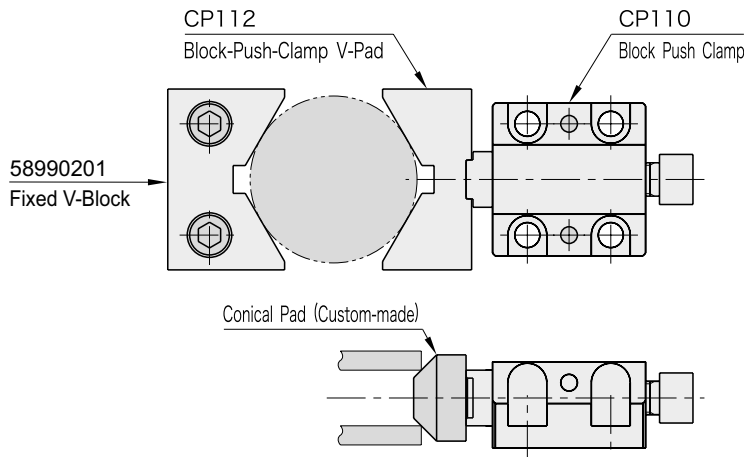

CP112

MOVABLE BLOCK PUSH CLAMP V-PADS

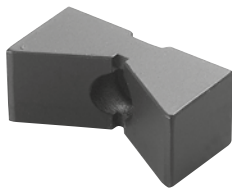

Material: S45C steel
Finish : Black oxide
Heat treated

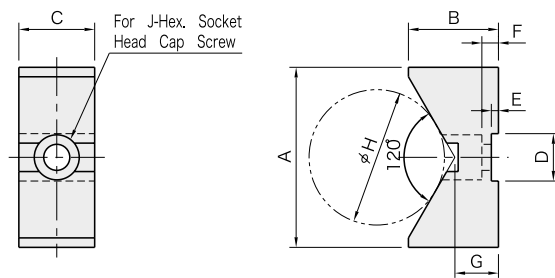

Part Number	A	B	C	D ($\frac{D}{\phi}$)	E	F	G	H		J	Weight (g)
								min.	max		
51991630	38	19	16	10	1.5	3.5	9.2	15	60	M 5	65
51991631	50	24	19	12	1.5	4.5	11	20	80	M 6	125
51991632	65	32	22	14	2	5.5	15	25	100	M 8	250
51991633	75	38	25	19	2.5	7.5	18.7	30	120	M10	390

CP112 F

FIXED V-BLOCK PUSH CLAMP



Material: S45C steel
Finish : Black oxide
Heat treated

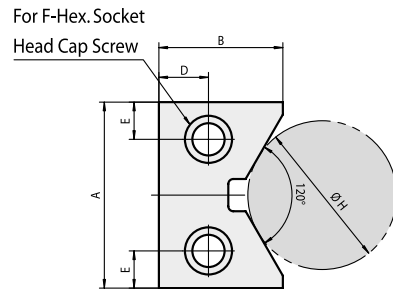

Part Number	A	B	C	D	E	F	H		Weight (Kg)
							min	max	
58990201	38	25	16	8	8	M6	15	60	0.09
58990202	50	35	19	10	10	M8	20	80	0.19
58990203	65	40	22	12	12	M10	25	100	0.30
58990204	75	50	25	20	15	M12	30	120	0.52

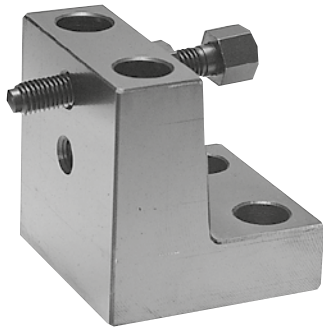

[Body]

- Material : S45C steel
- Black oxide finish

[Screw]

- Material : SCM435 steel
- Heat treated
- Black oxide finish

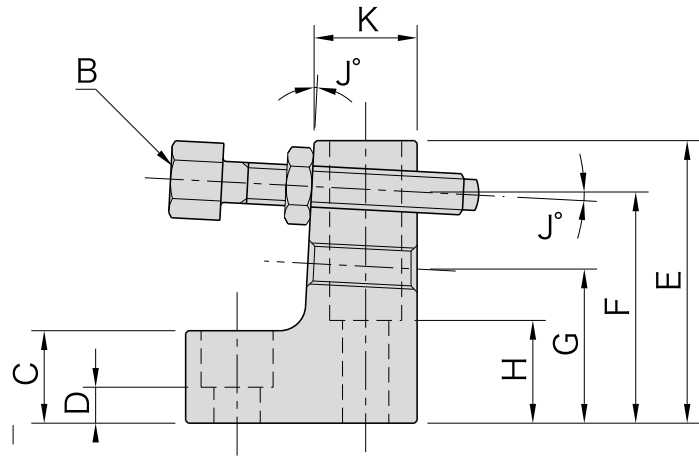
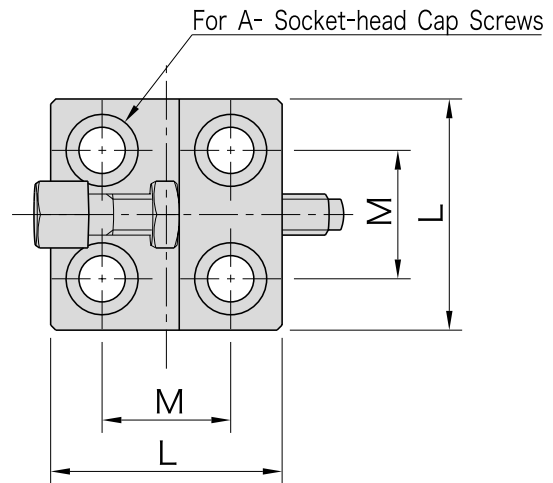

Part Number	A	B	C	D	E	F	G	H	J	K	L	M	Weight (kg)
51991634	M 8	M 8×1.25-50L	18	7	55	45	30	20	3	20	45	25	0.45
51991636	M16	M16×2 -80L	27	10	90	75	50	33	5	33	85	50	2.3

Application Examples

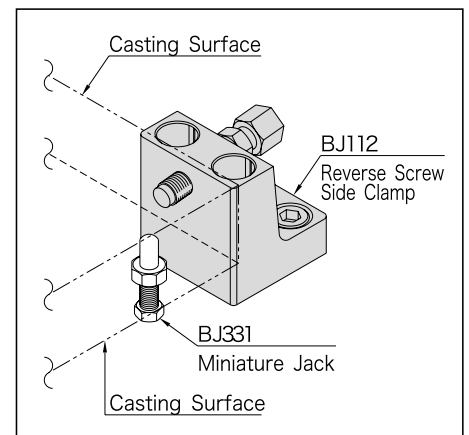
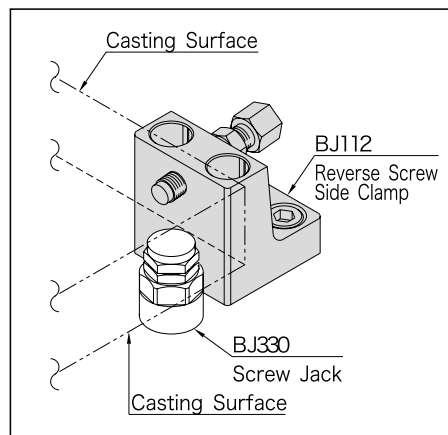
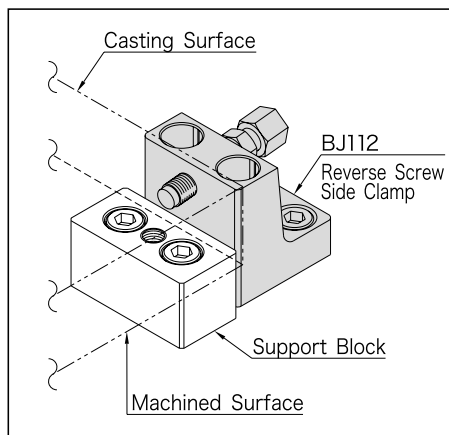



Material:SCM435 steel
Heat treated
Black oxide finish
Precision ground

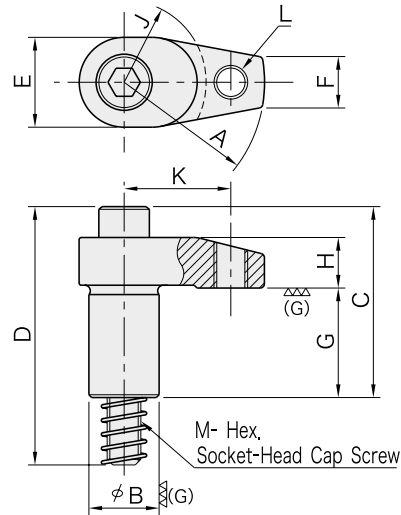

·Use with a BJ530 Hook-Clamp Holder.

How To Use (Reference)

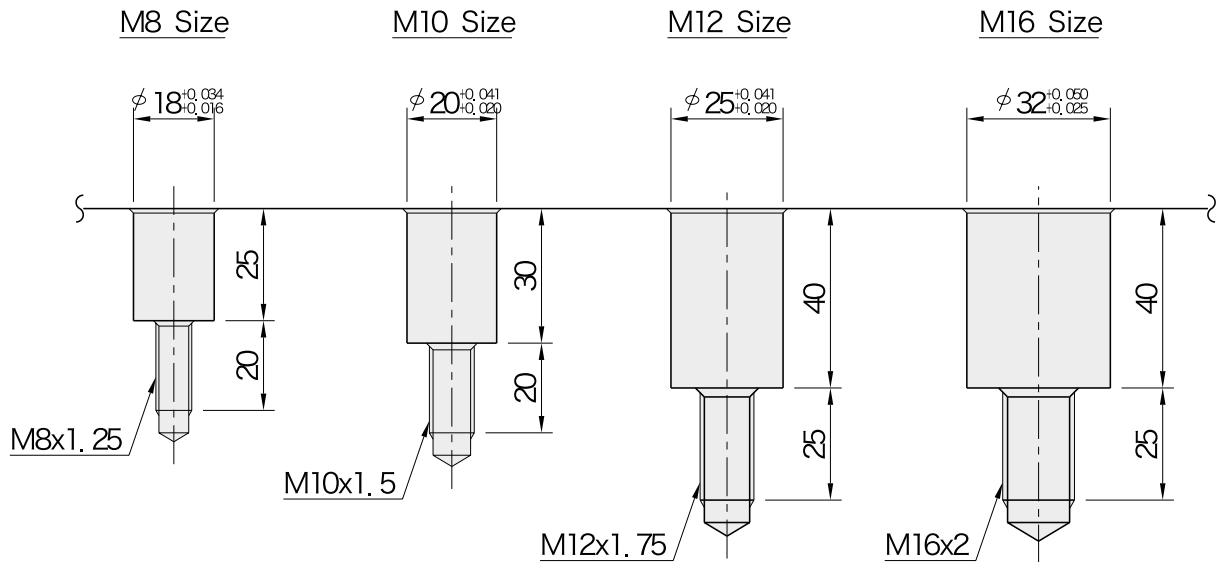

Hook Clamps can be plugged directly into custom blocks with receiving holes as specified above.

Part Number	A	B (h7)	C	D	E	F	G	H	J	K	L	M	Allowable Screw Torque (N·m)	Weight (Kg)
51991637	20	18	37	58	22	10	23	12	15	-	-	M8x1.25 - 50L	38	90
51991638	25								33				95	
51991639	30								30				105	
51991640	30	20	54	75	24	12	30	15	20	-	-	M10x1.5 - 65L	38	200
51991641	40								25				32	210
51991642	40								66				60	280
51991643	50	25	68	92	32	18	39	18	25	-	-	M12x1.75 - 80L	50	310
51991644	60												46	350
51991645	40												66	60
51991646	50	25	68	92	32	18	39	18	25	31	M12x1.75	M12x1.75 - 80L	50	310
51991647	60												46	350
51991648	40												66	60
51991649	50	32	75	101	36	22	39	21	25	-	-	M16x2 - 85L	170	420
51991650	60												150	470
51991651	50												130	530
51991652	60	32	75	101	36	22	39	21	25	38	M12x1.75	M16x2 - 85L	150	470
	60												46	130

BJ131

HOOK CLAMPS WITH SPRING



Material:SCM435 steel
Heat treated
Black oxide finish
Precision ground

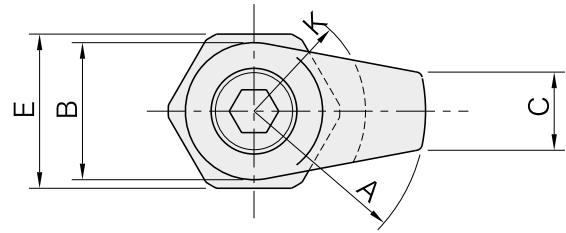

M- Hex. Socket-Head
Cap Screw

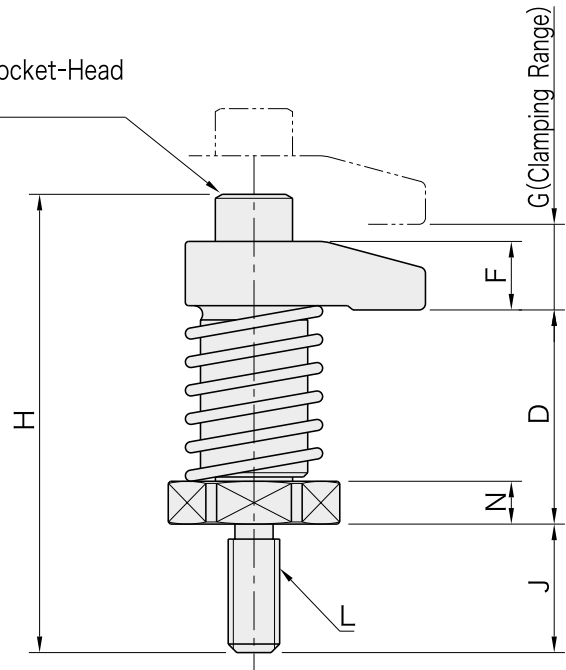

Part Number	A	B	C	D	E	F	G	H	J	K	L
51991655	30	22	10	35	22	12	10	68	19	20	M 8x1.25
51991659	40	32	18	50	36	16	15	107	30	25	M12x1.75
51991660	50					18		109			
51991661	60	36	22	50	36	21	15	116	30	25	M16x2
51991665	40										
51991666	50										
51991667	60										

Part Number	M	N	Clamping Force (N)	Allowable Screw Torque (N·m)	Weight (g)
51991655	M 8x1.25-30L	6	6.700	20	135
51991659	M12x1.75-45L	10	13.500	45	450
51991660			12.600		480
51991661			11.700		520
51991665	M16x2 -55L	10	13.400	60	630
51991666			12.400		680
51991667			12.000		740



Material: S45C steel
Black oxide finish

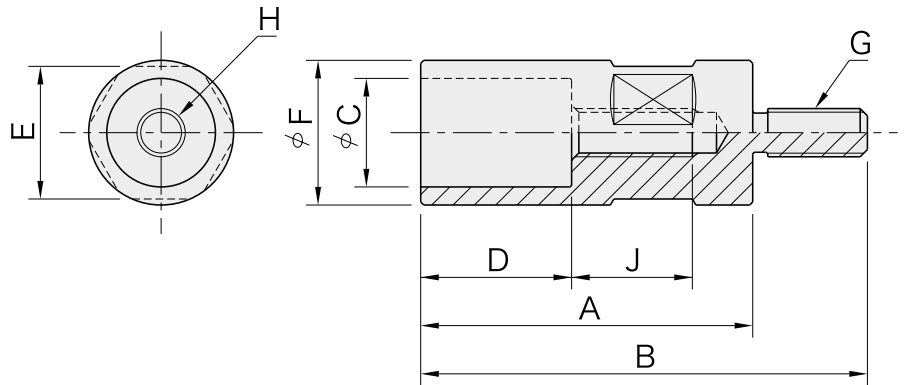

Part Number	A	B	C (F7)	D	E	F	G	H	J	Allowable Screw Torque (N·m) *)	Weight (g)
51991671	55	74	18	25	22	24	M 8x1.25	M 8x1.25	20	30	140
51991672	63	93	20	30	30	32	M12x1.75	M10x1.5	21	40	400
51991673	80	110									500
51991674	80	110	25	40	36	40	M12x1.75	M12x1.75	25	50	1.080
51991675	100	130									1.280
51991676	80	110	32	40	46	50	M16x2	M16x2	25	80	1.690
51991677	100	130									2.000

*) The above screw torque values are effective for installation of Hook Clamps.

How To Use



Holder that is specifically designed to receive a BJ130 Hook Clamp.

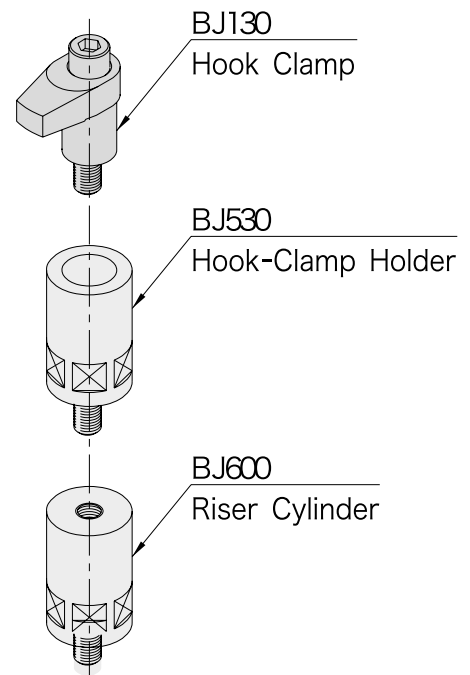



Material: SCM435 steel(Mini)
 S45C steel(Standard&heavy)
 Heat treated(Mini)
 Black oxide finish

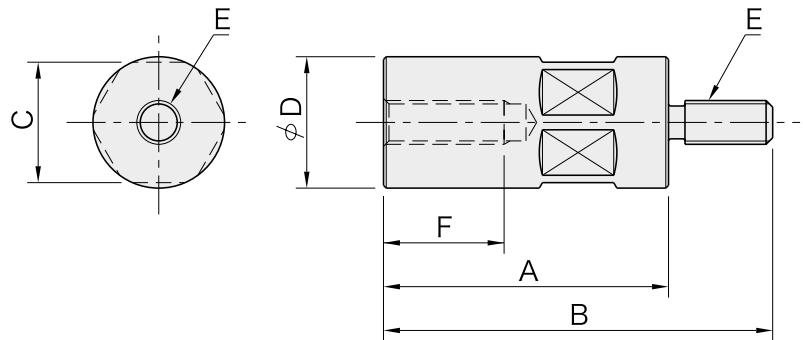

Part Number	A	B	C	D	E	F	Weight (g)
51991678	32	51	22	24	M 8x1.25	20	105
51991679	40	59					135
51991680	50	69					170
51991681	65	84					220
51991684	50	80	36	40	M12x1.75	35	480
51991685	65	95					640
51991686	80	110					780
51991687	100	130					980
51991688	125	155					1,230
51991691	50	80	46	50	M16x2	35	770
51991692	65	95					1,000
51991693	80	110					1,230
51991694	100	130					1,540
51991695	125	155					1,920

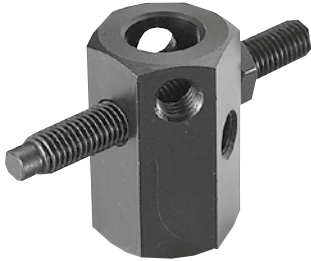

[Body]
 Material:S45C steel
 Black oxide finish

[Adjustment Screw]
 Material:Steel
 Heat treated
 Black oxide finish

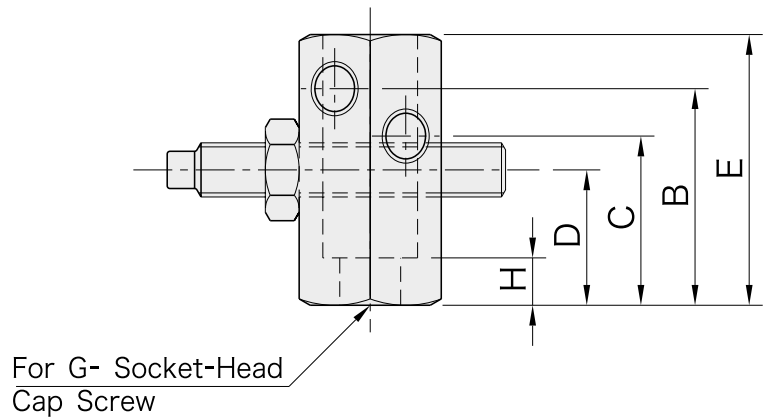
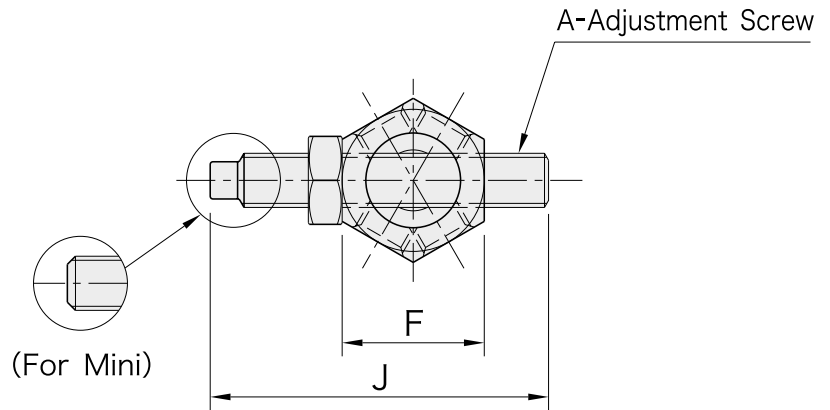

Part Number	A	B	C	D	E	F	G	H	J	Weight (g)
51991698	M 8x1.25	32	25	20	40	21	M 8	7	50	95
51991699	M12x1.75	50	40	32	60	36	M12	12	100	500
51991700	M16x2	63	50	40	80	46	M16	14	100	1,200

- Side stop that offers three options of screw height.
- Can also be used as auxiliary clamps.

BJ211

ADJUSTABLE MINIATURE STOPS

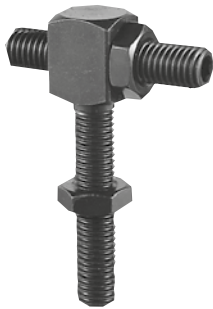

Material: S45C steel
Heat treated
Black oxide finish

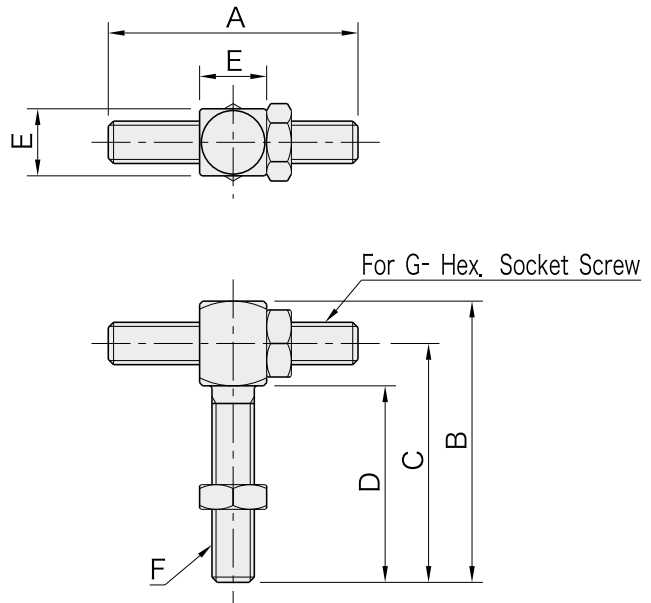

Part Number	A	B	C	D	E	F	G	Weight (g)
51991213	40	56	48	40	13	M 8x1.25	M 8x1.25	60
51991214	50	70	60	50	17	M10x1.5	M10x1.5	120
51991215	60	84	72	60	19	M12x1.75	M12x1.75	190
51991216	80	112	96	80	24	M16x2	M16x2	410

Application Examples

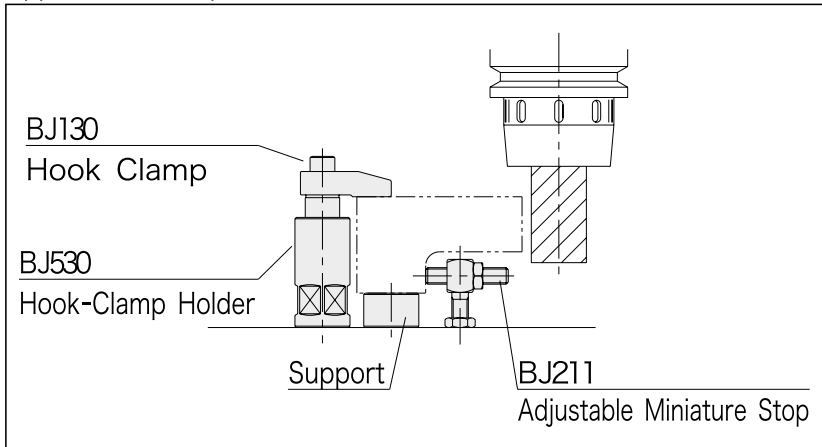

Miniature size allows use in small space.

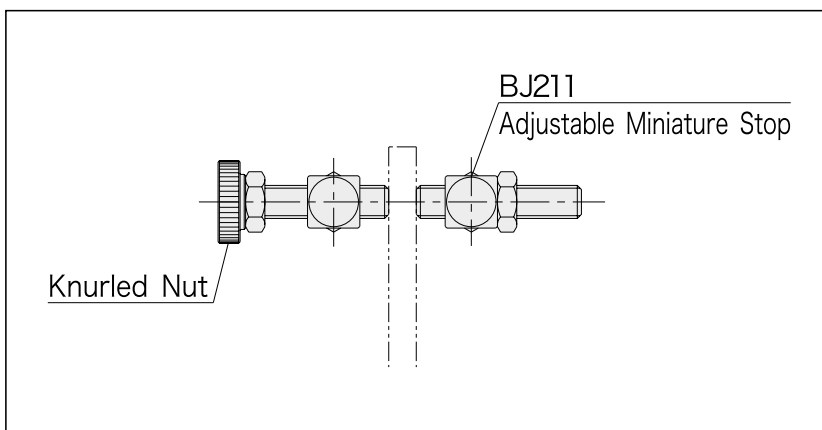
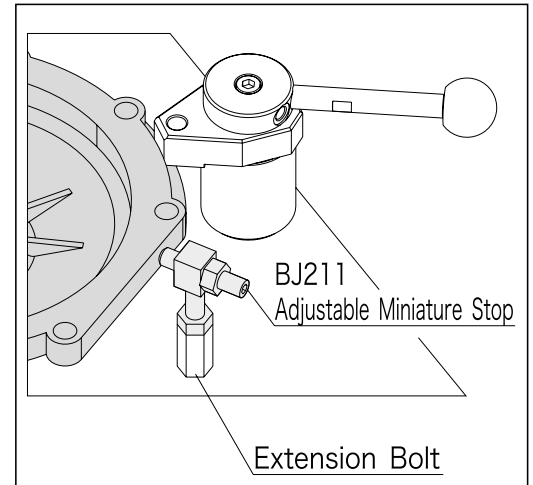

Can be used as auxiliary clamps.



Material: S45C steel
 Finish : Black oxide
 Heat treated

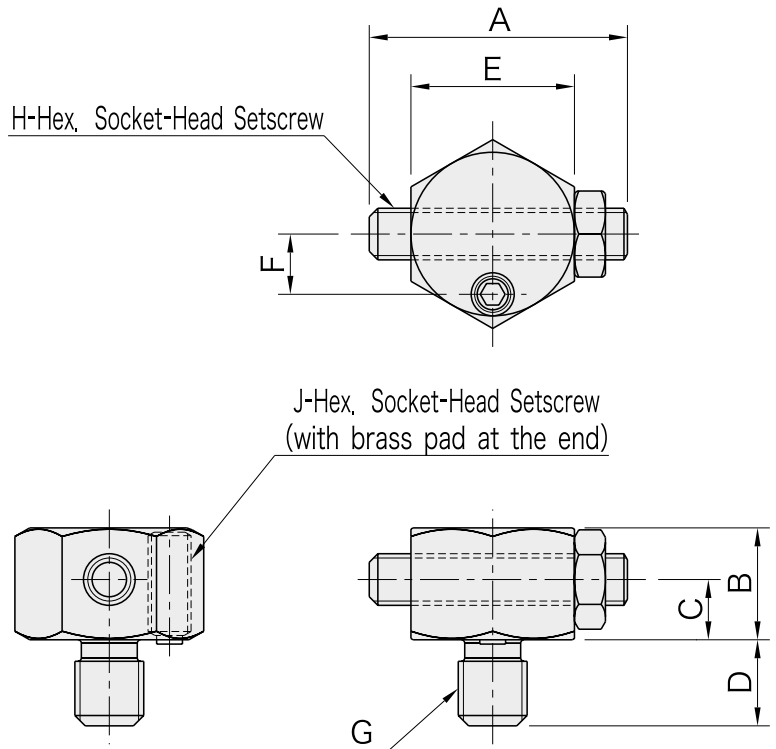

Part Number	A	B	C	D	E	F	G	H	J	Weight (g)
51991701	30	13	7	10	19	7	M 8x1.25	M 6x1	M5x0.8-12L	40
51991702	40	16.5	8.5	12	22	8	M10x1.5	M 8x1.25	M5x0.8-12L	75
51991703	50	21	11	15	24	9	M12x1.75	M10x1.5	M6x1 -20L	120
51991704	60	23	12	20	30	12	M16x2	M12x1.75	M6x1 -20L	210

How To Use

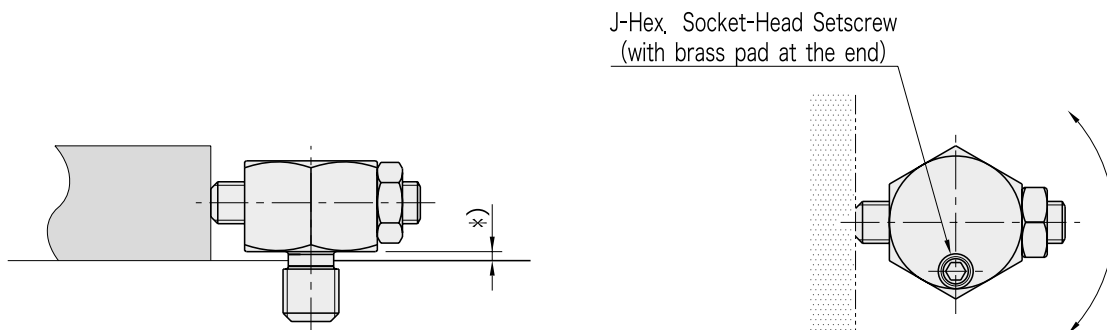

*) Minimize this clearance when installing.

Installation Information

1. Screw in the body completely.
2. Screw back the body and set the adjustment screw.
3. Tighten up the hex, socket-head setscrew to lock the body.

·Use to stop a low-profile workpiece.

BJ360

COMPACT WORK SUPPORTS



[Body]
 Material: S45C steel
 Finish : Black oxide

[Piston]
 Material: SK4 steel
 Finish : Black oxide
 Heat treated

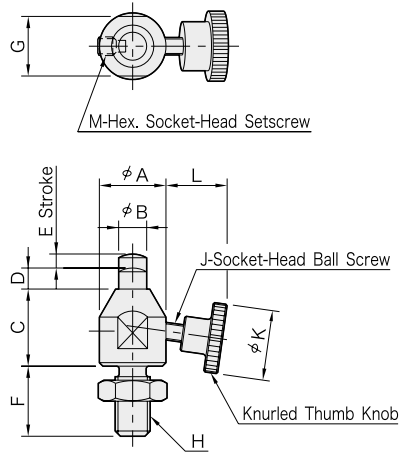

Note) The socket-head ball screw is glued to the knurled thumb knob.

How To Use

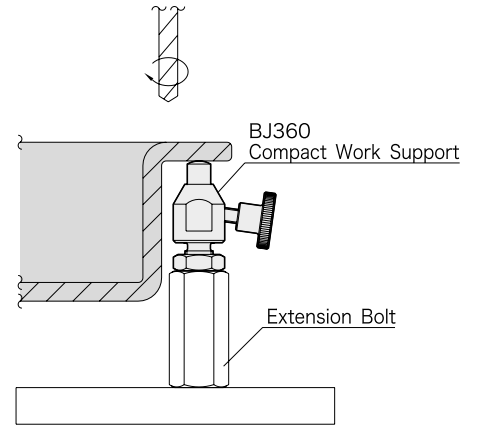

Part Number	A	B	C	D	E	F	G	H	J	K
51991148	15	6	18	5	3	16	13	M 8x1.25	M4x0.7-16L	16
51991149	19	8	22	6	4	20	17	M10x1.5	M5x0.8-20L	20
51991150	22	10	25			24	19	M12x1.75	M6x1 -25L	24

Part Number	L	M	Piston Spring Force (N)	Support Capacity (N)	Weight (g)
51991148	13.2	M4x0.7-6L	1.5 to 3.0	200	36
51991149	16.3		1.8 to 3.0	300	72
51991150	22.3		400	150	

BJ350

WORK SUPPORTS



[Body]
Material:S45C steel
Black oxide finish

[Piston]
Material:SK4 steel
Heat treated
Black oxide finish

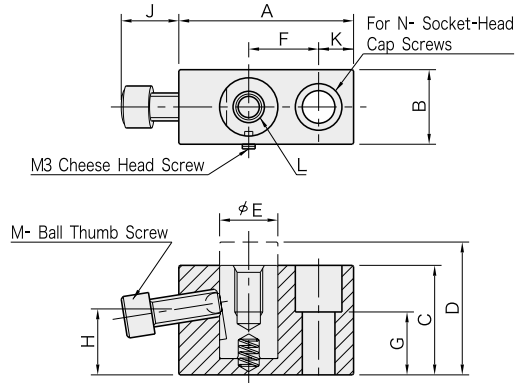

Application Example

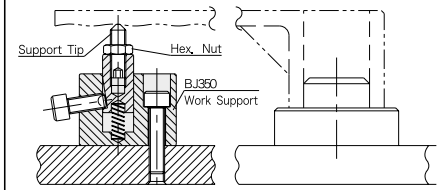

Ideal for preventing the workpiece from chattering and deflecting.

- The positive locking mechanism offers high support capacities.
- The above support capacity values are reached when the ball thumb screw is fully tightened.

Part Number	A	B	C	D	E	F	G	H	J	K
51991152	38	19	29	35	12	15	15	17.6	13	8
51991153	50	22	37	47	16	20	20	21.1	16	10
51991154	65	25	42	52	19	25	20	24.6	18.5	15
51991155	75	32	47	57	25	30	27	28.3	25	15

Part Number	L	M	N	Support Capacity (N)	Piston Spring Force (N)	Weight (g)
51991152	M 6x1 10 deep	M 6x1 -16L	M 6	4,000	0 to 6	150
51991153	M 8x1.25 15 deep	M 8x1.25 -20L	M 8	6,000	0 to 7	285
51991154	M10x1.5 15 deep	M10x1.5 -25L	M10	7,500	1 to 11	480
51991155	M12x1.75 20 deep	M12x1.75 -30L	M12	9,000	1 to 11	800

BJ351

WORK SUPPORT CYLINDERS

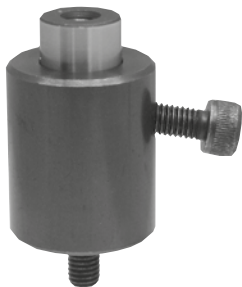

[Body]
Material:S45C steel
Black oxide finish

[Piston]
Material:SK4 steel
Heat treated
Black oxide finish

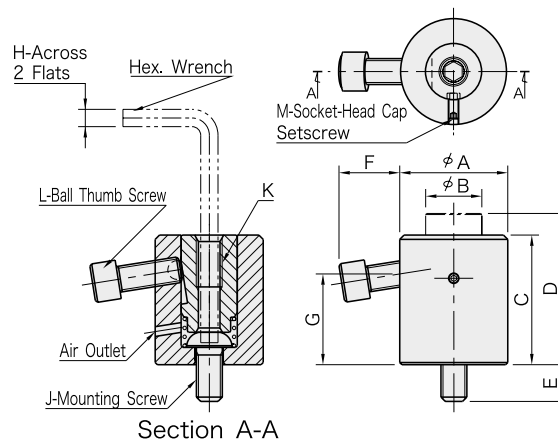

To install, insert a hex. wrench through the piston into the mounting screw.

Application Example

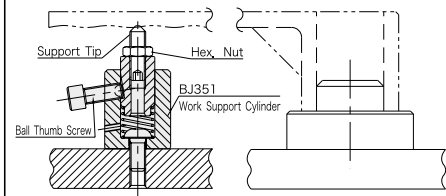

Ideal for preventing the workpiece from chattering and deflecting.

- The positive locking mechanism offers high support capacities.
- The above support capacity values are reached when the ball thumb screw is fully tightened.

Part Number	A	B	C	D	E	F	G	H	J	K
51991156	28	14	33	39	10	13.1	22.2	4	M 6x1	M 6x1 12 deep
51991157	35	19	42	52	14	17.2	27.5	5	M 8x1.25	M 8x1.25 16 deep
51991158	42	22	50	-	14	23.8	34	6	M 10x1.5	M 10x1.5 20 deep
51991159	50	26	60	70	16	28.1	42.1	8	M 12x1.75	M 12x1.75 24 deep
51991160	60	33	70	80	22	26.6	47.4	10	M 16x2	M 16x2 32 deep

Part Number	L	M	Support capacity (N)	Piston Spring Force (N)	Weight (g)
51991156	M 6x1 -16L	M4x0.7 - 8L	4,000	10 ~ 22	150
51991157	M 8x1.25 -20L	M4x0.7 - 8L	6,000	10 ~ 27	300
51991158	M 10x1.5 -25L	-	7,500	14 ~ 28	540
51991159	M 12x1.75 -30L	M5x0.8 - 12L	9,000	15 ~ 30	865
51991160	M 16x2 -30L	M5x0.8 - 12L	9,000	15 ~ 35	1390

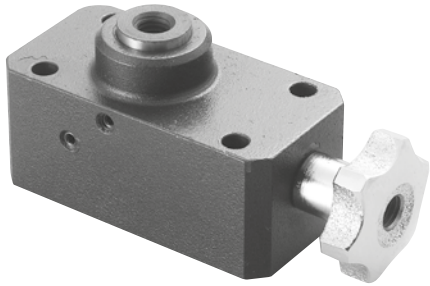

[Body]
 Material: S45C steel
 Finish : Black oxide

[Piston & Locking Pin]
 Material: SK4 steel
 Finish : Black oxide
 Heat Treated

[Spindle]
 Material: S45C steel
 Finish : Black oxide
 Heat Treated

[Piston Plug]
 Material: S45C steel
 Finish : Black oxide

[Knob]
 Material: FC200 cast iron
 Finish : Chrome plated

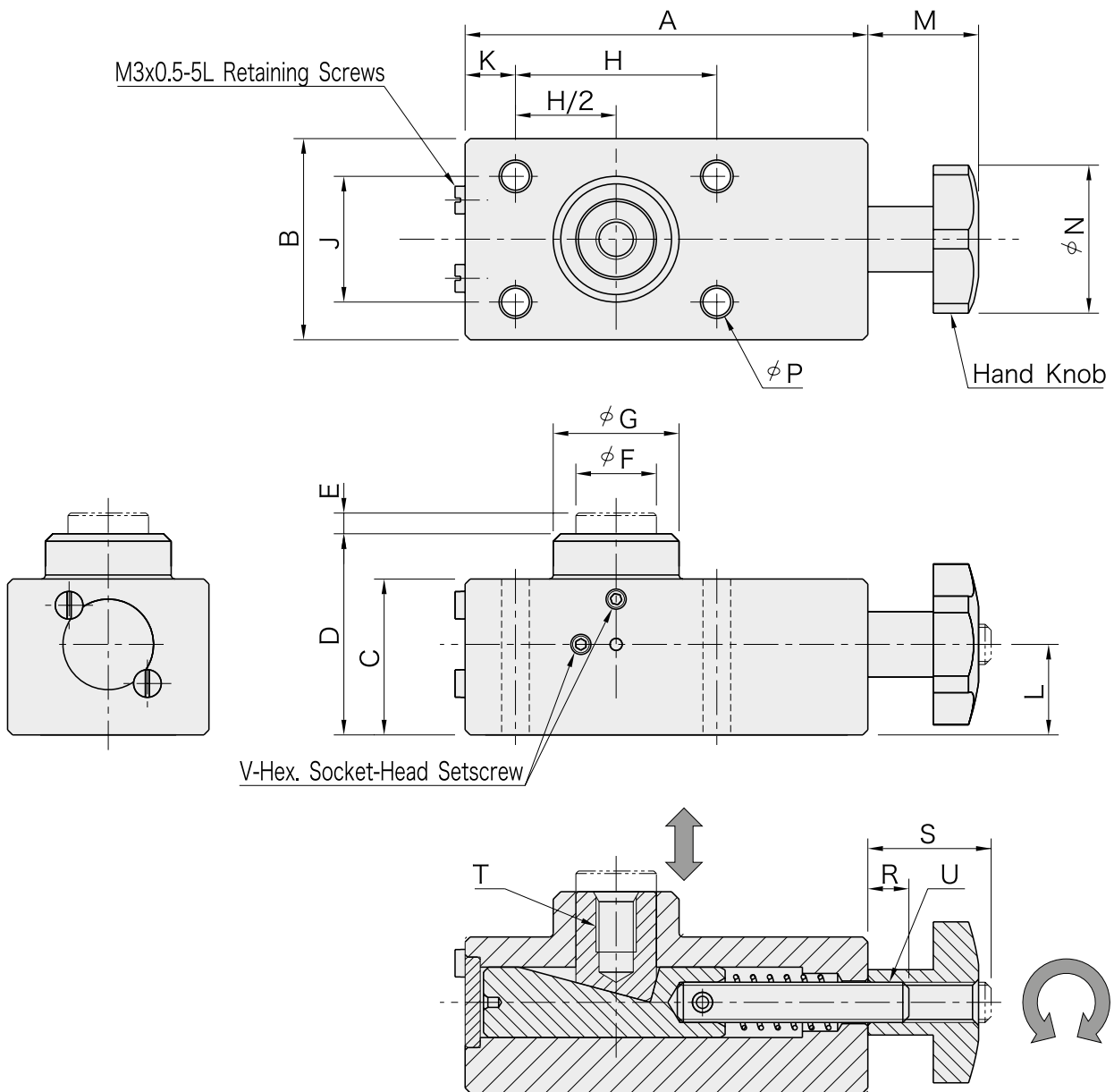

Turning the hand knob clockwise lets the locking pin move upward and turning it counterclockwise lets the locking pin move downward.

Part Number	A	B	C	D	E	F	G	H	J	K	L	M	N	P	R	S
51991709	80	40	31	40	4	16	25	40	25	10	18	22	32	5.5	8	23.5
51991710	95	50	39	50	5	20	32	50	30	10	23	25	40	6.5	9	28
51991711	115	60	47	60	6	24	38	60	40	15	28	32	50	9	12	35.5

Part Number	T	U	V	Support Capacity(N)	Allowable Screw Torque (N·m)	Weight (kg)
51991709	M 8x1.25 12 deep	M 8x1.25	M4x0.7-10L	700	1	0.82
51991710	M10x1.5 15 deep	M10x1.5	M4x0.7-10L	800	1.5	1.52
51991711	M12x1.75 18 deep	M12x1.75	M5x0.8-16L	900	2	2.67

Note : The stated values of both "Support Capacity" and "Allowable Screw Torque" are based on the manual operation of the hand knob.

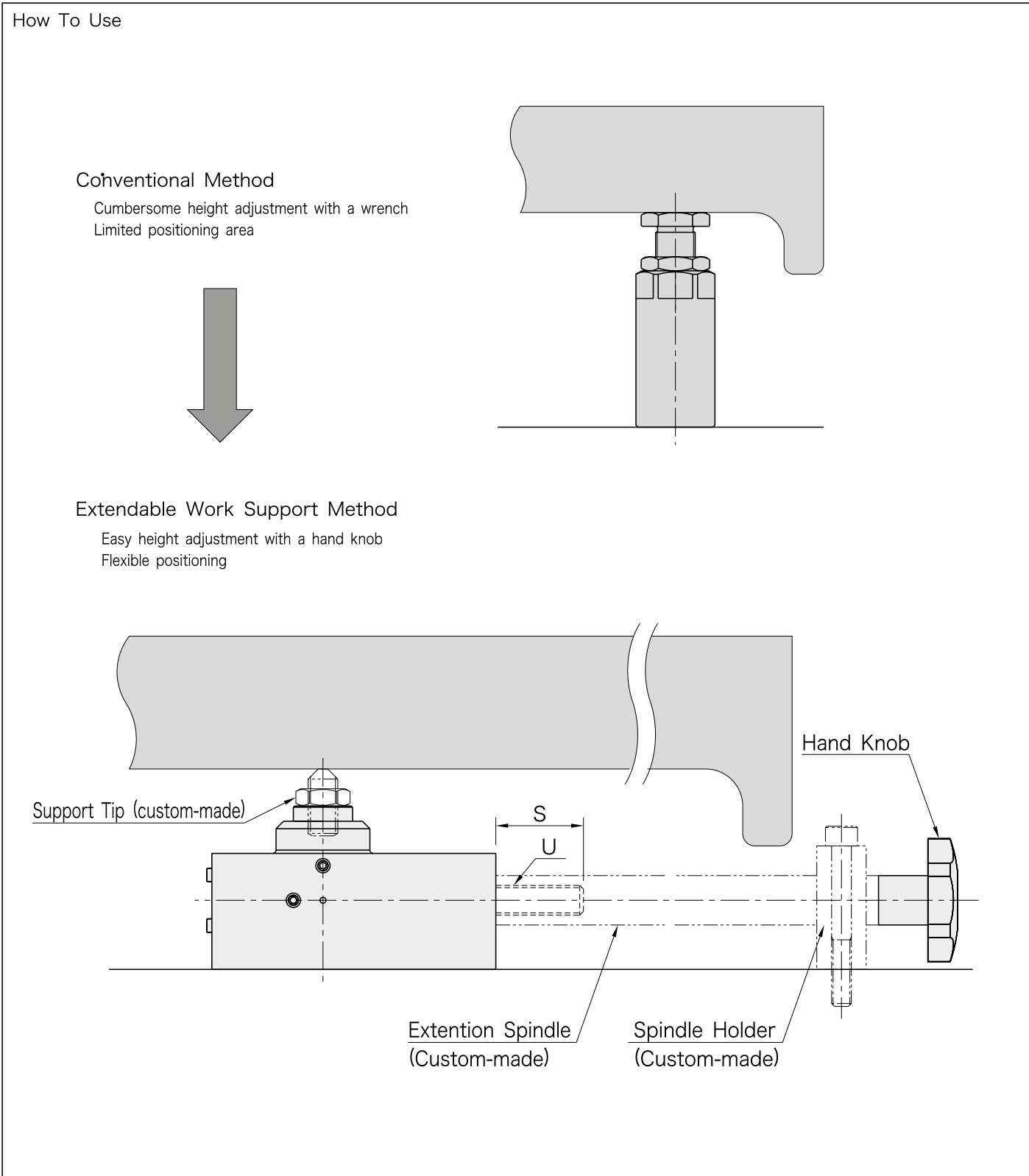

- Connecting an extension spindle allows adjusting the part height with ease.
- Provide a tapped hole for the extension spindle for connection, as specified in chart above.

BJ330

SCREW JACKS

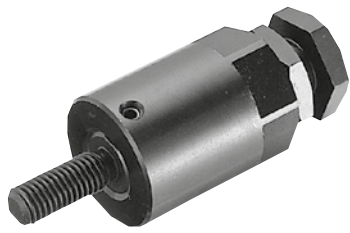

[Body]

Material:S45C steel
Black oxide finish

[Bolt]

Material:SCM435 steel
Heat treated
Black oxide finish

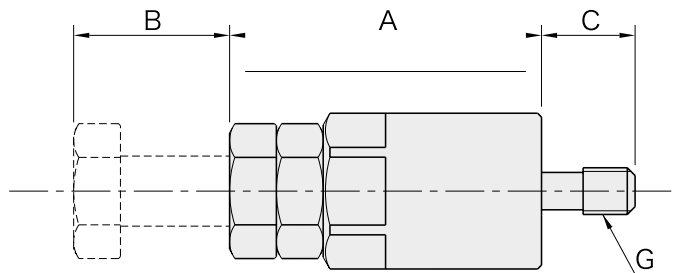
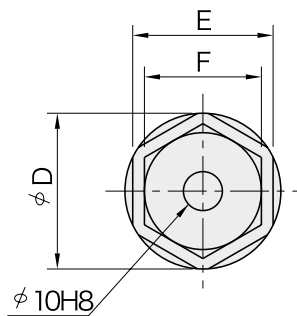

Part Number	A	B	C	D	E	F	G	Load Capacity (N)	Weight (g)
51991712	40	10	30	40	36	30	M12x1.75	31,800	350
51991713	50	20							420
51991714	70	40							570
51991718	50	20	30	40	36	30	M16x2	31,800	430
51991719	70	40							580

BJ733

SCREW-JACK TIP



Material:S45C steel
Heat treated
Black oxide finish

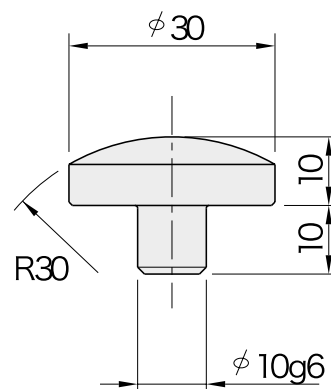

Part Number	Weight (g)
51991722	50

BJ331

MINIATURE JACKS

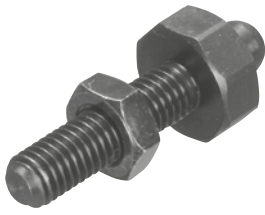

Material: S45C steel
Heat treated
Black oxide finish
Hardness: RC33 - 39

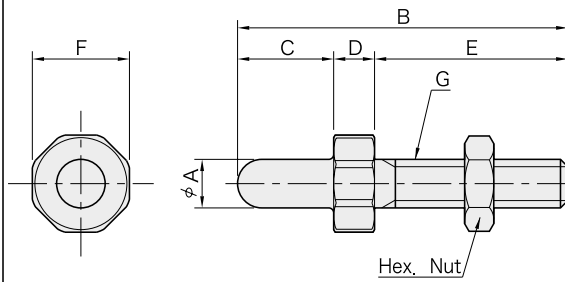

How To Use

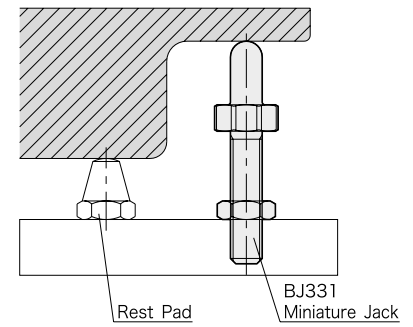

Part Number	A	B	C	D	E	F	G	Weight (g)
51991161	6	37	6	6	25	13	M 6x1	11
51991162		43	12					13
51991163	8	45	8	7	30	17	M 8x1.25	40
51991164		53	16					45
51991165	10	58	10	8	40	19	M10x1.5	60
51991166		68	20					65
51991167	12	72	12	10	50	24	M12x1.75	110
51991168		84	24					120
51991169	16	89	16	13	60	30	M16x2	240
51991170		105	32					265

BJ332

JACK SCREWS



Material: S45C steel
Finish : Black oxide

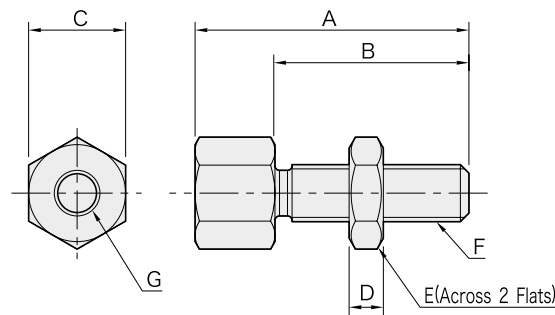

How To Use

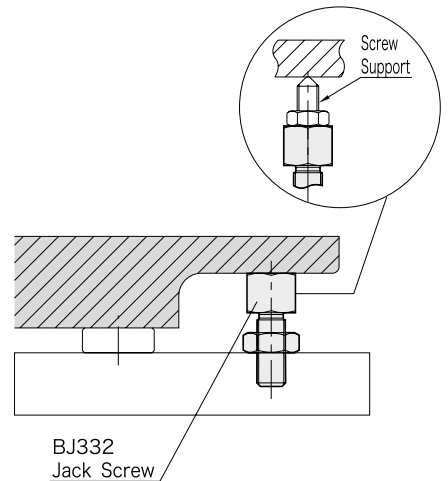

Part Number	A	B	C	D	E	F	G	Weight (g)
51991173	30	20	13	5	13	M 8x1.25	M 6x1 6 deep	20
51991174	40	30						25
51991175	38	24	17	6	17	M10x1.5	M 8x1.25 8 deep	45
51991176	48	34						50
51991177	51	33	22	7	22	M12x1.75	M10x1.5 10 deep	95
51991178	66	48						110
51991179	62	40	27	10	27	M16x2	M12x1.75 12 deep	185
51991180	77	55						210

BJ333

SMALL SCREW JACKS



Material: S45C steel
Finish : Black oxide

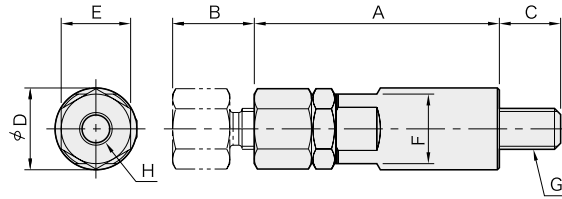

How To Use

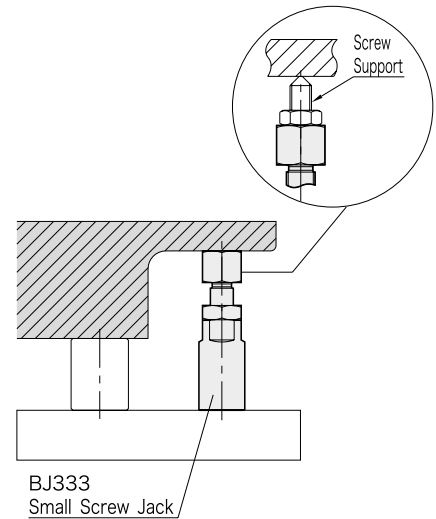

Part Number	A	B	C	D	E	F	G	H	Weight (g)
51991181	40	10	12	16	13	13	M 8 x1.25	M 6x1 6 deep	55
51991182	50	20							70
51991183	50	10	14	20	17	17	M10x1.5	M 8x1.25 8 deep	110
51991184	60	20							135
51991185	65	15	19	24	22	22	M12x1.75	M10x1.5 10 deep	220
51991186	80	30							275
51991187	80	15	24	32	27	27	M16x2	M12x1.75 12 deep	460
51991188	95	30							555

BJ601

SMALL RISER CYLINDERS



Material: S45C steel
Finish : Black oxide

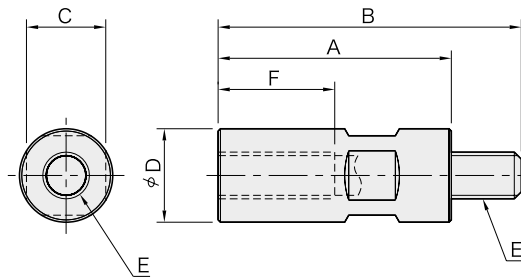

How To Use

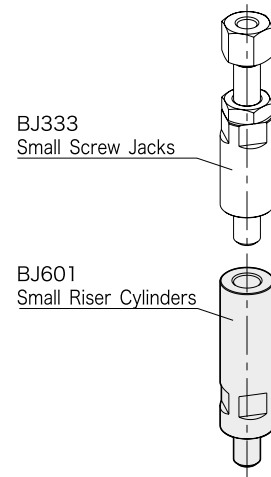

Part Number	A	B	C	D	E	F	Weight (g)
51991189	32	44	13	16	M 8X1.25	18	45
51991190	40	52				55	
51991191	50	62				70	
51991192	65	77				90	
51991193	80	92				115	
51991194	100	112				145	
51991195	40	54				17	20
51991196	50	64	105				
51991197	65	79	145				
51991198	80	94	180				
51991199	100	114	230				

Part Number	A	B	C	D	E	F	Weight (g)
51991201	50	69	22	24	M12X1.75	30	160
51991202	65	84					200
51991203	80	99					255
51991204	100	119					325
51991205	125	144					415
51991206	160	179					540
51991207	50	74					27
51991208	65	89	350				
51991209	80	104	430				
51991210	100	124	560				
51991211	125	149	715				
51991212	160	184	935				



Material:S45C steel
 Heat treated
 Black oxide finish
 Precision ground
 Hardness:RC39 - 45

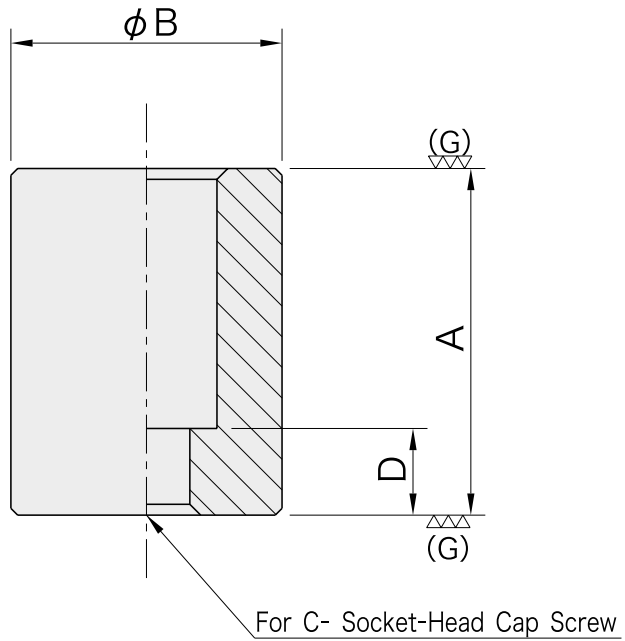

Part Number	A (± 0.01)	B	C	D	Weight (g)	
51991723	16	25	M 8	7	47	
51991724	20				58	
51991725	25				71	
51991726	32				89	
51991727	40				110	
51991728	50				136	
51991729	20	32	M10	9	97	
51991730	25				120	
51991731	32				151	
51991732	40				186	
51991733	50				229	
51991734	63				287	
51991735	20	40	M12	7	160	
51991736	25				200	
51991737	32				260	
51991738	40				330	
51991739	50			12	12	420
51991740	63					530
51991741	80					660
51991742	100					840
51991744	25	50	M16	8	350	
51991745	32				390	
51991746	40			15	15	500
51991747	50					630
51991748	63					810
51991749	80					1.000
51991750	100			35	35	1.260
51991751	125					1.600

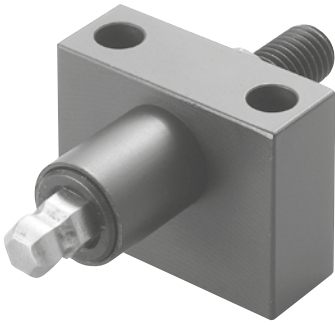

Material: S45C steel
Finish : Black oxide

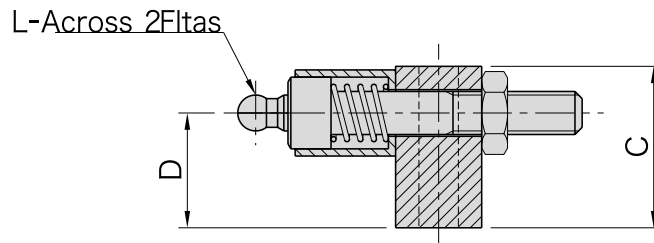
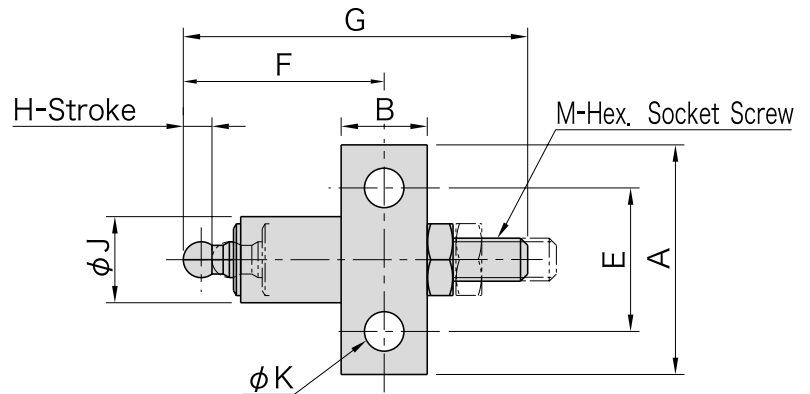

Short

Part Number	A	B	C	D	E	F	G	H	J	K
51991752	32	12	22	16	20	30	48	4	12	5.5
51991753	32	12	27	19.2	20	34	57	4	15	5.5
51991754	44	16	32	22.2	30	45	76	5	18	9
51991755	44	16	36	25.2	30	50	86	5	20	9

Part Number	L	M	Work Supports BJ 350	Weight (g)	Recommended Distance between Work Supprt and Remote-Control Unit A
51991752	5	M 6x1 -35L	51991152	75	66
51991753	6	M 8x1.25-40L	51991153	100	81
51991754	8	M10x1.5 -55L	51991154	210	103
51991755	10	M12x1.75-60L	51991155	250	121

Tall

Part Number	A	B	C	D	E	F	G	H	J	K
51991756	32	12	26	20	20	30	48	4	12	5.5
51991757	32	12	33	25.2	20	34	57	4	15	5.5
51991759	44	16	49	38.2	30	50	86	5	20	9
51991760	44	16	54	43.7	30	50	86	5	20	9

Part Number	L	M	Work Supports BJ 351	Weight (g)	A: Recommended Distance between Work Support and Remote-Control Unit
51991756	5	M 6x1 -35L	51991156	85	52
51991757	6	M 8x1.25-40L	51991157	115	62
51991759	10	M12x1.75-60L	51991159	310	92
51991760	10	M12x1.75-60L	51991160	335	95



[Body]
 Material:S45C steel
 Heat treated (M6&M8 sizes)
 Black oxide finish

[Ball]
 Material:SUJ2
 Heat treated

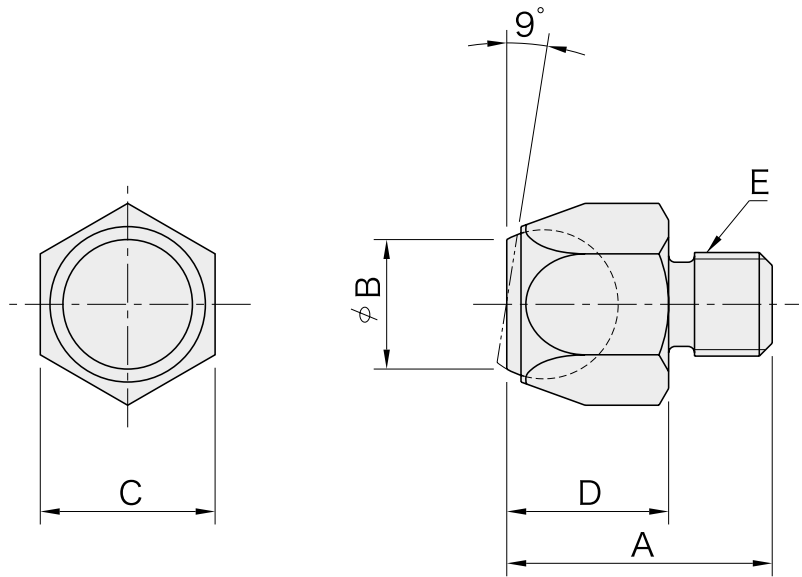

Part Number	A	B	C	D	E	Load Capacity (N)	Weight (g)
51991770	16	7.4	10	9	M 6x1	13.700	12
51991771	21	10.5	13	12	M 8x1.25	25.600	15
51991772	27	12.7	17	16	M10x1.5	40.000	45
51991773	32	15	22	20	M12x1.75	59.400	50
51991774	41	20	27	25	M16x2	96.400	115

Application Example

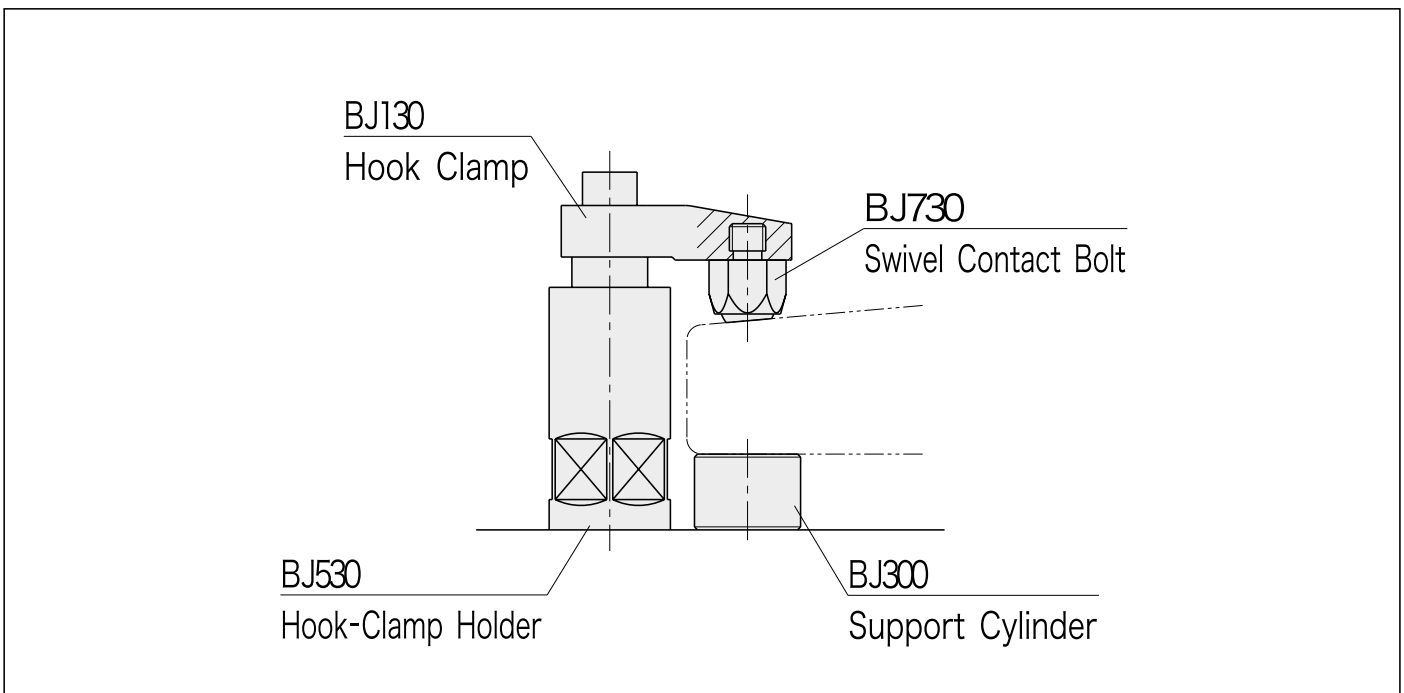

·Use to clamp from above and/or below a workpiece.
 ·Ball swivel is not limited.

BJ731

TOGGLE PADS



Material: S45C steel
Heat treated (contact surface)
Black oxide finish

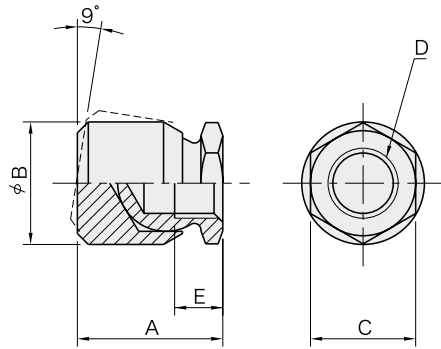

Application Example

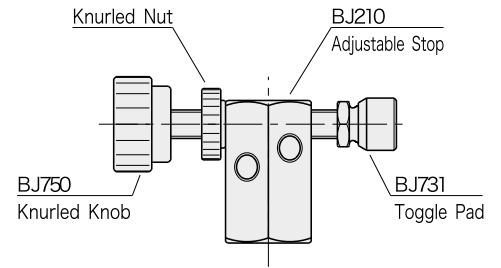

Use to distribute clamping pressure to irregular workpiece surfaces.

Part Number	A	B	C	D	E	Load Capacity (N)		Weight (g)
						Static	Repeated	
51991775	17	15	13	M 8x1.25	6	8.000	5.300	18
51991776	25	22	19	M12x1.75	8	15.900	10.600	60
51991777	33	28	24	M16x2	10	26.700	17.800	130

BJ732

CONTACT BOLTS



Material: SCM435 steel
Heat treated
Black oxide finish
Heat treated on edge

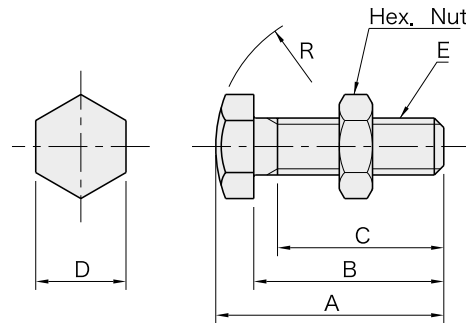

Application Example

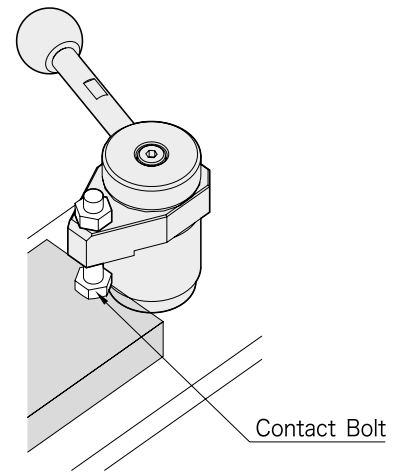

Part Number	A	B	C	D	E	R	Weight (g)
51991235	30	25	22	10	M 6x1	R15	7
51991236	40	35	32				9
51991237	50	45	42				11
51991238	36	30	27	13	M 8x1.25	R17.5	16
51991239	46	40	37				19
51991240	56	50	47				22
51991241	48	40	37	17	M10x1.5	R20	33
51991242	58	50	47				38
51991243	68	60	57				42
51991244	50	40	35	19	M12x1.75	R30	60
51991245	70	60	55				65
51991246	80	70	65				70
51991247	55	45	40	24	M16x2	R35	110
51991248	75	65	60				125
51991249	85	75	70				135

BJ746

SOCKET TOGGLE SCREWS



Material:S45C steel
Heat treated
Black oxide finish

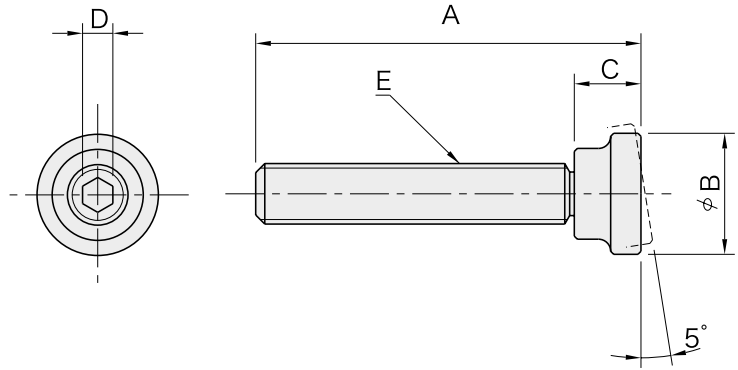

Part Number	A	B	C	D	E	Weight (g)
51991780	43	16	9	4	M 8x1.25	28
51991781	63					37
51991782	83					46
51991783	64	20	11	5	M10x1.5	50
51991784	84					60
51991785	104					70
51991786	65	25	13	6	M12x1.75	75
51991787	85					95
51991788	105					110
51991789	130	32	15	8	M16x2	130
51991790	85					170
51991791	105					190
51991792	130	155				230
51991793	155					265

BJ748

CLAMP SCREWS



Material:SCM435 steel
Heat treated
Black oxide finish
Hardness:RC33 - 39

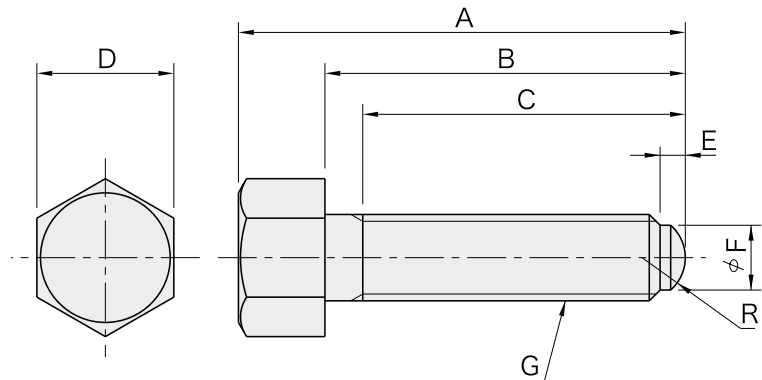

Part Number	A	B	C	D	E	F	G	R	Clamping Force (N)	Allowable Screw Torque (N·m)	Weight (g)
51991800	50	40	37	13	3	5.5	M 8x1.25	R 6	53.000	84	21
51991801	60	50	47								24
51991802	70	60	57								26
51991803	52	40	37	17	3.5	7.5	M10x1.5	R 8	89.000	178	38
51991804	62	50	47								42
51991805	72	60	57								46
51991806	75	60	55	19	5	9	M12x1.75	R 9	100.000	240	70
51991807	95	80	75								80
51991808	115	100	95								95
51991809	140	125	120	24	6	12	M16x2	R12	130.000	417	115
51991810	100	80	75								165
51991811	120	100	95								185
51991812	145	125	120								215

BJ750

KNURLED KNOBS



Material:S45C steel
Finish :Black oxide

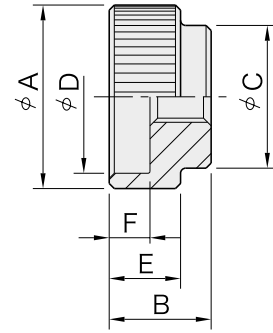
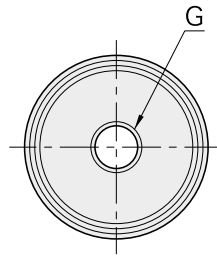

Part Number	A	B	C	D	E	F	G	Weight (g)
51991819	30	17	20	24	12	7	M 8x1.25	50
51991820	36	20	28	30	14	8	M10x1.5	90
51991821	40	24	32	34	16	10	M12x1.75	125

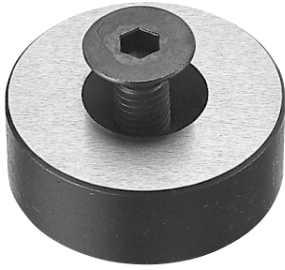

- Material: S45C steel
- Heat treated
- Black oxide finish
- Precision ground
- Hardness: RC39 to 45

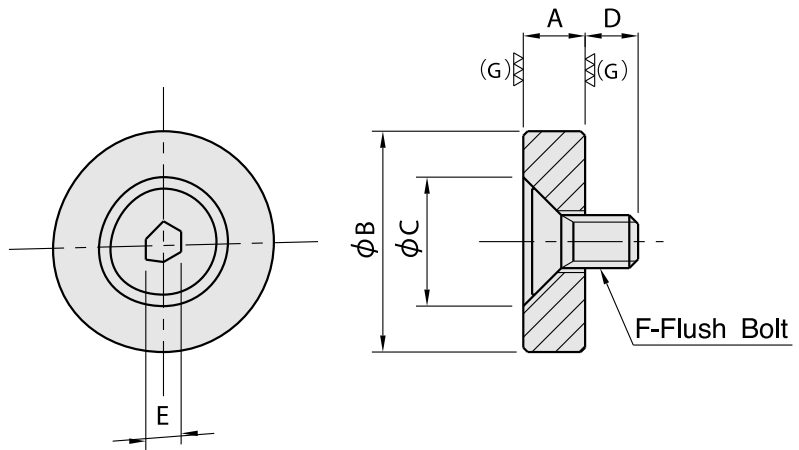

Code	A ($+0.01$ 0)	ϕB	ϕC	D	E	F	Weight (g)
51 99 18 67	5	25	14	7.7	4	M6 x 1	20
51 99 18 68		30					30
51 99 18 69		35					40
51 99 18 70	10	25	19.4	10.7	4	M6 x 1	40
51 99 18 71		30					60
51 99 18 72		35					80
51 99 18 73	10	30	19.4	11.3	5	M8 x 1.25	60
51 99 18 74		35					80
51 99 18 75		40					100
51 99 18 76	15	30	19.4	11.3	5	M8 x 1.25	90
51 99 18 77		35					115
51 99 18 78		40					150

Application Example

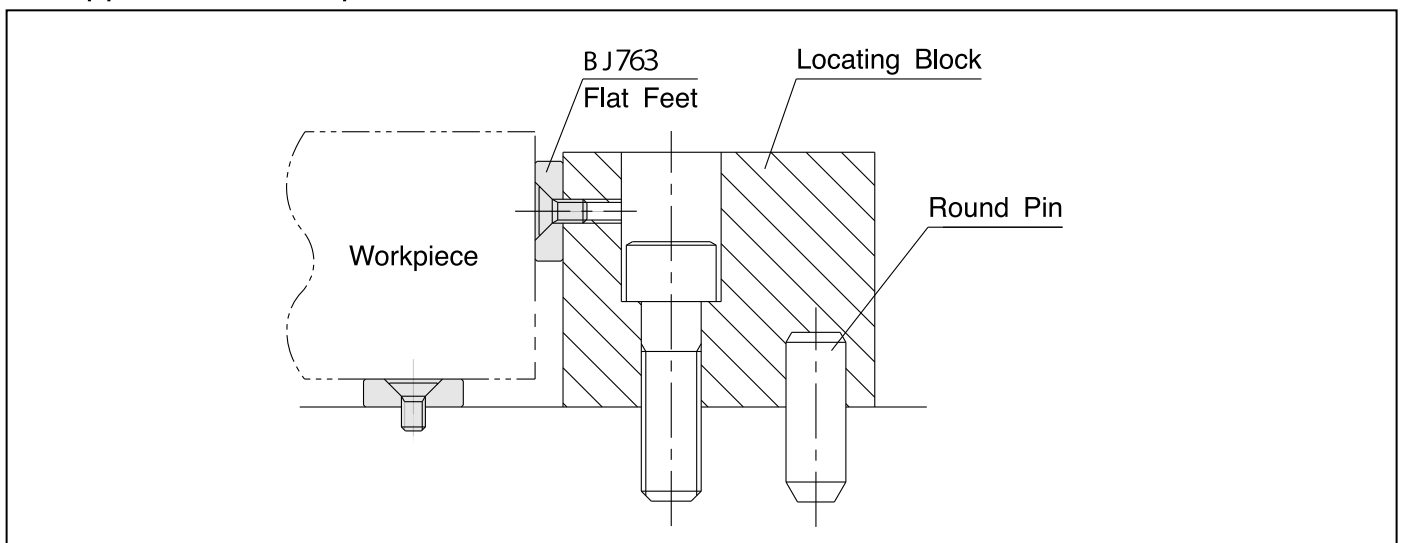

Precision locator that keeps workpieces machined surfaces out of damage.
 The accuracy of a locating block with Flat Feet installed can easily be compensated by regrinding the feet.

BJ810

REST PADS

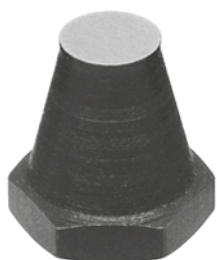

(Ground)

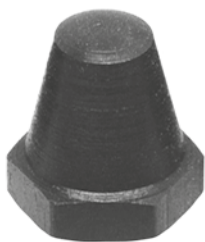

(Round)

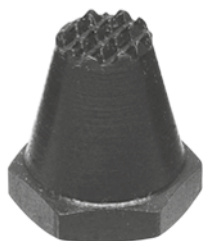

(Serrated)

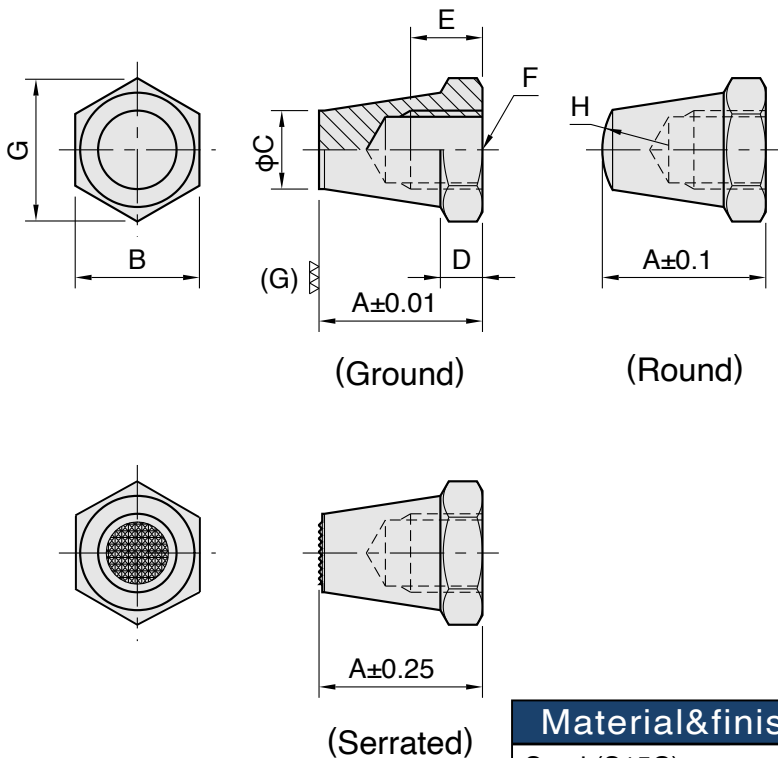

Material&finish

Steel (S15C)
Carburized-hardened
Black oxide finish

Ground code	Round code	Serrated code	A	B	C	D	E	F	G	H	Weight (g)
51 99 18 79	51 99 18 80	51 99 18 81	12.5	11	6	3	4	M 6x1	12.7	5	5
51 99 18 82	51 99 18 83	51 99 18 84	25				7				8
51 99 18 85	51 99 18 86	51 99 18 87	15	13	8	4	6	M 8x1.25	15	8.5	9
51 99 18 88	51 99 18 89	51 99 18 90	30				9				18
51 99 18 91	51 99 18 92	51 99 18 93	20	17	10	5	9	M10x1.5	19.6	9	17
51 99 18 94	51 99 18 95	51 99 18 96	40				13				35
51 99 18 97	51 99 18 98	51 99 18 99	25	19	12	6	11	M12x1.75	21.9	12.8	25
51 99 19 00	51 99 19 01	51 99 19 02	50				16				62



(Ground)



(Round)



(Serrated)

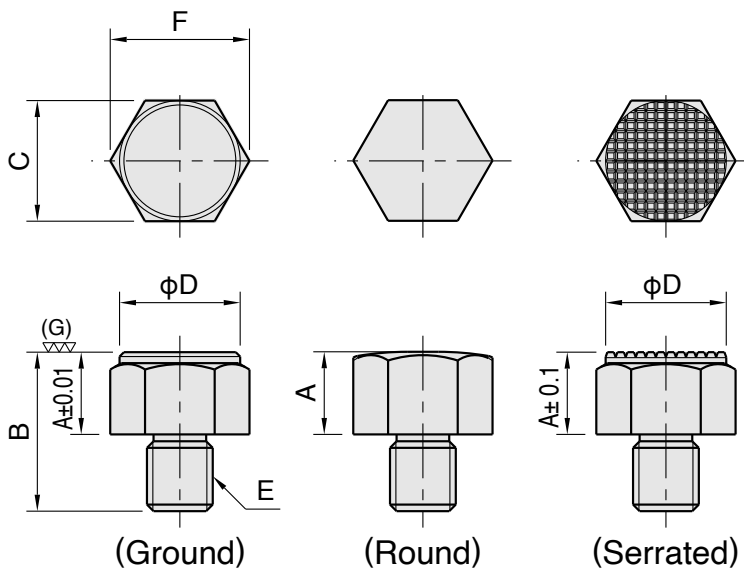

Material&finish

Steel (SUM22L)
 Carburized - hardened
 Black oxide finish

Ground code	Round code	Serrated code	A	B	C	D	E	F	Weight (g)
51 99 19 03	51 99 19 04	51 99 19 05	10	20	17	17	M 8x1.25	19.4	24
51 99 19 06	51 99 19 07	51 99 19 08		24	22	22			40
51 99 19 09	51 99 19 10	51 99 19 11	15	29			M12x1.75	25.2	56



(Ground)

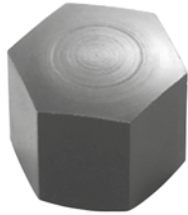

(Round)



(Serrated)

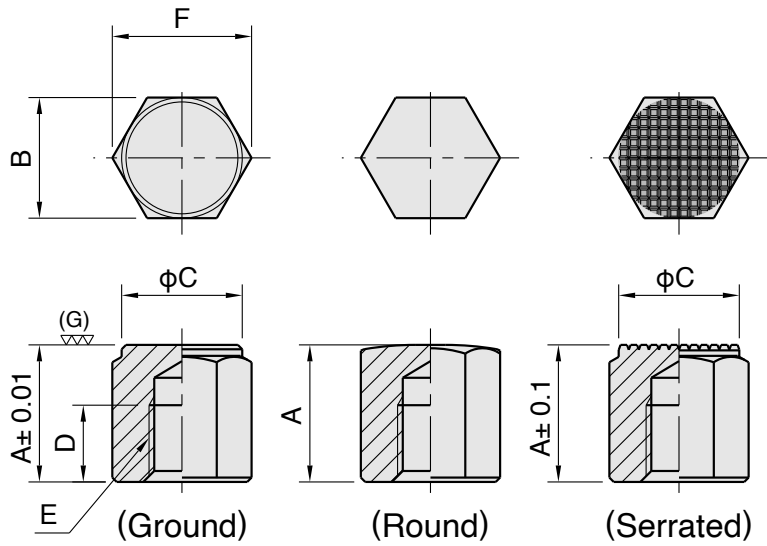

Material&finish

Steel(SUM22L)
Carburized-hardened
Black oxide finish

Ground code	Round code	Serrated code	A	B	C	D	E	F	Weight (g)
51 99 19 12	51 99 19 13	51 99 19 14	15	17	17	6	M 8x1.25	19.4	23
51 99 19 15	51 99 19 16	51 99 19 17	25			16			40
51 99 19 18	51 99 19 19	51 99 19 20	20	22	22	10	M12x1.75	25.2	52
51 99 19 21	51 99 19 22	51 99 19 23	25			15			65
51 99 19 24	51 99 19 25	51 99 19 26	30			20			77
51 99 19 27	51 99 19 28	51 99 19 29	40	50		25			105
51 99 19 30	51 99 19 31	51 99 19 32	50						135

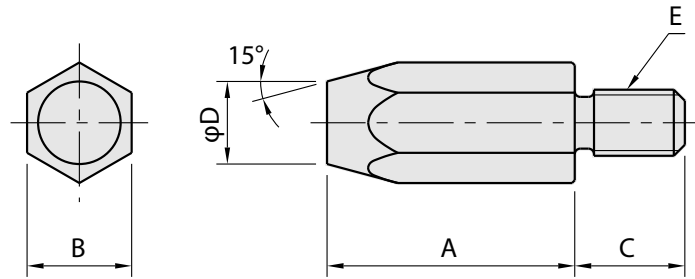

Material&finish

Steel (S45C)
 Quenched and tempered
 Black oxide finish
 Heat treated to Rc33-39

Part Number	A	B	C	D	E	weight (g)
51 99 19 42	10	10	11	8	M 6x1	6
51 99 19 43	20			6		13
51 99 19 44	15	13	13	10	M 8x1.25	18
51 99 19 45	30			9		33
51 99 19 46	20	17	16	13	M10x1.5	44
51 99 19 47	40					80
51 99 19 48	25	19	20	15	M12x1.75	70
51 99 19 49	50					120



(Plain)



(Serrated)

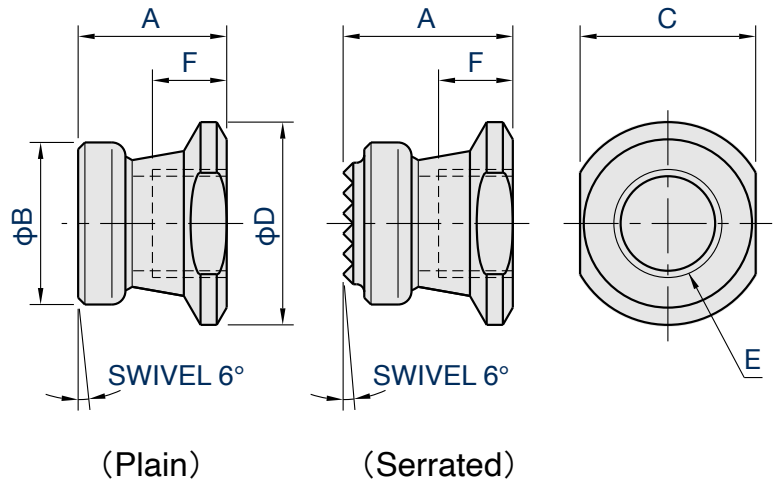

Type	Body	Pad	Insert Tip
Plain	Steel (SCM440)	Steel (SCM440) Quenched and tempered	-
Serrated	Black oxide finish	Black oxide finish Heat treated to Rc36-40	Carbide Black oxide finish

code	A	B	C	D	E	F	Load Capacity (N)	Weight (g)
51 99 19 50	15.5	14	12	14.3	M 6x1	5.5	5,000	9
51 99 19 51	13							
51 99 19 52	19.5	16	14	16	M 8x1.25	7	10,000	13
51 99 19 53	17							
51 99 19 54	21.5	18	16	19.1	M10x1.5	8	13,000	21
51 99 19 55	18							
51 99 19 56	25.5	21	22	25.4	M12x1.75	9.5	24,000	34
51 99 19 57	22							
51 99 19 58	28	24	22	25.4	M16x2	11	38,000	50
51 99 19 59	25							
51 99 19 60	33	28	30	31.5	M20x2.5	13.5	57,000	82
51 99 19 61	29							



(Steel)



(Plastic)

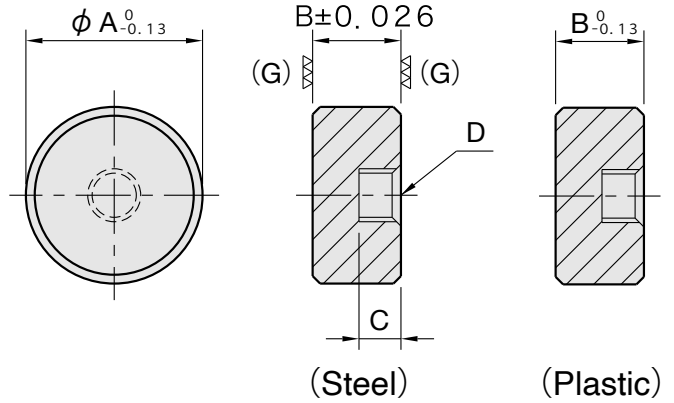

Type	Material & Finish
Steel	Steel (SNCM220) Carburized-hardened Black oxide finish Heat treated to Rc60
Plastic	Polyacetal plastic White

Steel		Plastic		A	B	C	D
Part Number	Weight (g)	Part Number	Weight (g)				
51 99 19 62	5	51 99 19 68	1	10	10	5	M5×0.8
51 99 19 63	8	51 99 19 69	2	12	10	5	M5×0.8
51 99 19 64	10	51 99 19 70	2	12	12	6.4	M5×0.8
51 99 19 65	15	51 99 19 71	3	16	10	5	M6×1
51 99 19 66	23	51 99 19 72	4	20	10	5	M6×1
51 99 19 67	37	51 99 19 73	7	25	10	5	M6×1

Application Examples

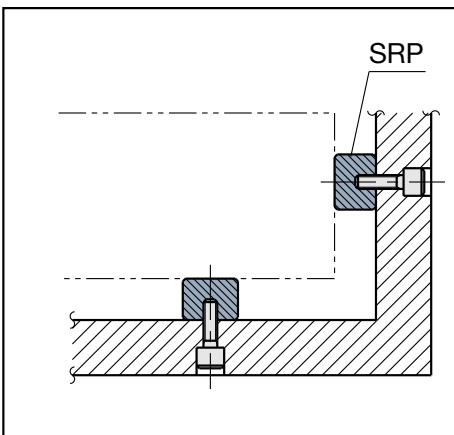

• Workpiece positioning

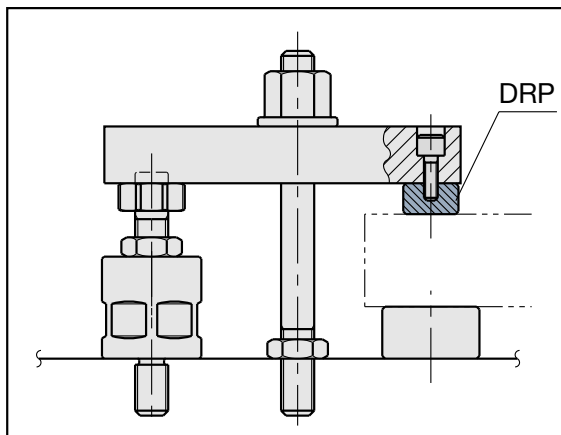

• Protecting a soft or precision ground workpiece.

HS

ROUND GRIPPERS, Tapped

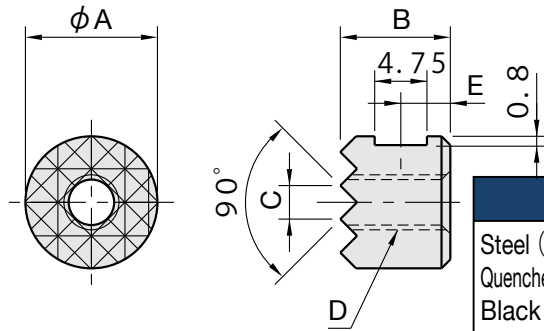
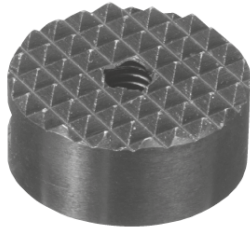

Steel (SKH51)
 Quenched and tempered
 Black oxide finish
 Heat treated to Rc62

Part Number	A ($^0_{-0.13}$)	B ($^0_{-0.13}$)	C	D	E	Weight (g)
51 99 19 74	10	10	2.3	M5x0.8	4.5	5
51 99 19 75		12			6	6
51 99 19 76	12	10	3	M5x0.8	4.5	8
51 99 19 77		12			6	9
51 99 19 78	16	10	3	M6x1	4.5	14
51 99 19 79		12			6	15
51 99 19 80	20	10	3	M6x1	4.5	23
51 99 19 81		12			6	25
51 99 19 82	25	10	3	M6x1	4.5	37
51 99 19 83		12			6	40

HS

SQUARE GRIPPERS, Tapped

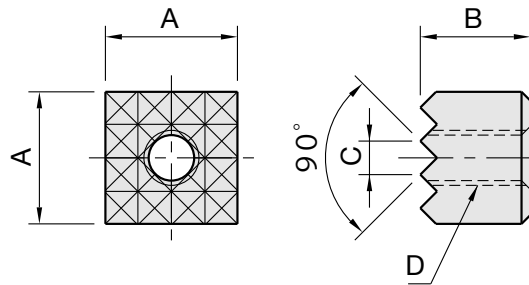
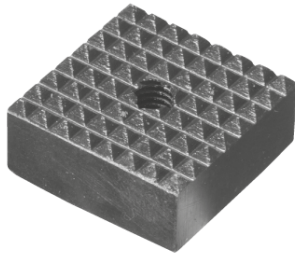

Material & Finish

Steel (SKH51)
 Quenched and tempered
 Black oxide finish
 Heat treated to Rc62

Part Number	A ($^0_{-0.13}$)	B ($^0_{-0.13}$)	C	D	Weight (g)
51 99 19 84	10	10	2.3	M5x0.8	7
51 99 19 85		12			7.5
51 99 19 86	12	10	3	M5x0.8	10
51 99 19 87		12			11
51 99 19 88	16	10	3	M6x1	17
51 99 19 89	20	10	3	M5x0.8	30
51 99 19 90		12			33.5
51 99 19 91	25	10	3	M6x1	47
51 99 19 92		12			53

HS-C

ROUND GRIPPERS, C'Bored

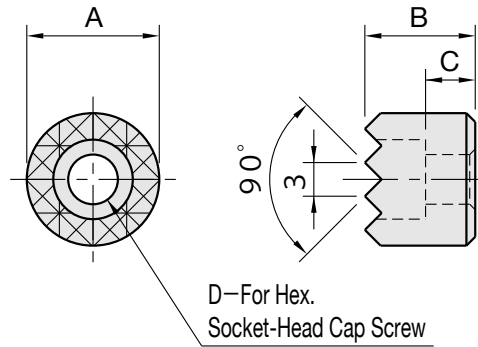
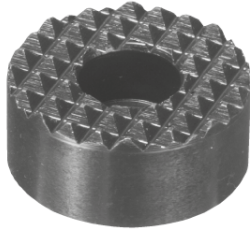

Steel (SKH51)
Quenched and tempered
Black oxide finish
Heat treated to Rc62

Part Number	A ($\begin{smallmatrix} 0 \\ -0.13 \end{smallmatrix}$)	B ($\begin{smallmatrix} 0 \\ -0.13 \end{smallmatrix}$)	C	D	Weight (g)
51 99 19 93	12	10	4.5	M4	6
51 99 19 94		12	6.5		8
51 99 19 95	16	10	4.5	M4	12
51 99 19 96		12	6.5		15
51 99 19 97	20	10	3.5	M5	19
51 99 19 98		12	5.5		23
51 99 19 99	25	10	2.5	M6	30
51 99 20 00		12	4.5		38

HS-C

SQUARE GRIPPERS, C'Bored

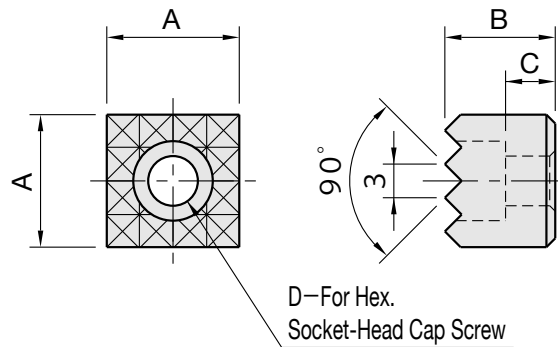
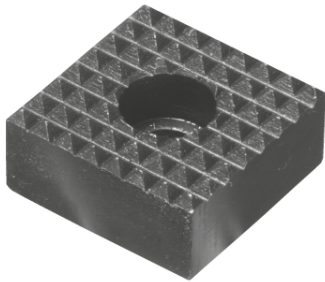

Steel (SKH51)
Quenched and tempered
Black oxide finish
Heat treated to Rc62

Part Number	A ($\begin{smallmatrix} 0 \\ -0.13 \end{smallmatrix}$)	B ($\begin{smallmatrix} 0 \\ -0.13 \end{smallmatrix}$)	C	D	Weight (g)
51 99 20 01	12	10	4.5	M4	8
51 99 20 02		12	6.5		10
51 99 20 03	16	10	4.5	M4	16
51 99 20 04	20	10	3.5	M5	25
51 99 20 05		12	5.5		31
51 99 20 06	25	10	2.5	M6	40
51 99 20 07		12	4.5		49

CT

ROUND GRIPPERS

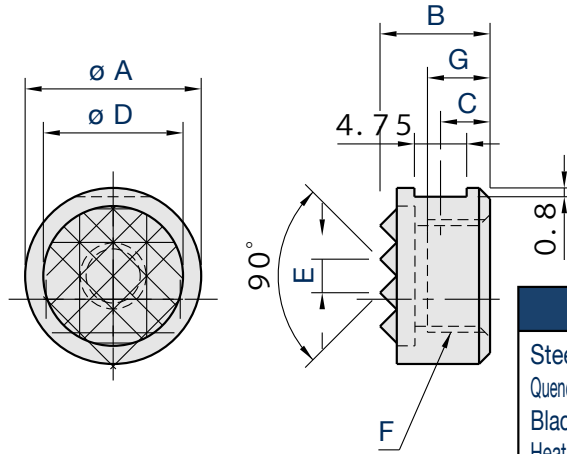

Body	Tip
Steel (SCM440) Quenched and tempered Black oxide finish Heat treated to Rc32	Carbide Black oxide finish

code	A ($\begin{smallmatrix} 0 \\ -0.13 \end{smallmatrix}$)	B ($\begin{smallmatrix} 0 \\ -0.13 \end{smallmatrix}$)	C	D	E	F	G Effective Thread Length	Weight (g)
51 99 20 08	10	10	4.5	7.9	2.3	M5×0.8	6.5	5
51 99 20 09		12	6				8.5	6
51 99 20 10	12	10	4.5	9.5	3	M5×0.8	6.5	8
51 99 20 11		12	6				8.5	9
51 99 20 12	16	10	4.5	12.7	3	M6×1	6.5	14
51 99 20 13		12	6				8.5	17
51 99 20 14	20	10	4.5	15.9	3	M6×1	6.5	23
51 99 20 15		12	6				8.5	28
51 99 20 16	25	10	4.5	19.1	3	M6×1	6.5	35
51 99 20 17		12	6				8.5	43

CT

SQUARE GRIPPERS

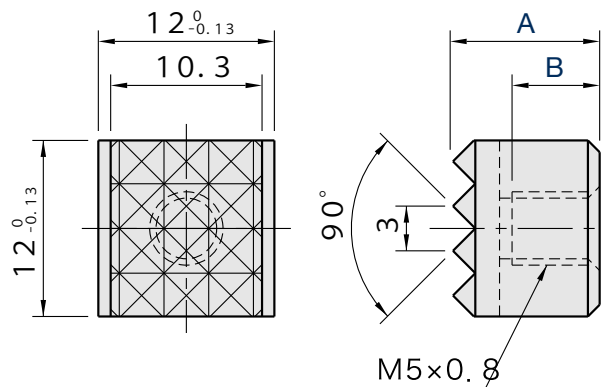
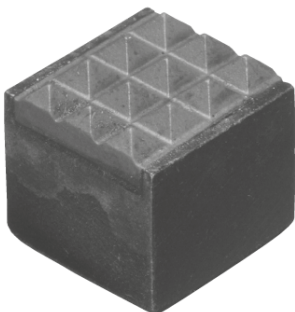

code	A ($\begin{smallmatrix} 0 \\ -0.13 \end{smallmatrix}$)	B Effective Thread Length	Weight (g)
51 99 20 18	10	6.5	10
51 99 20 19	12	8.5	13

Body	Tip
Steel (SCM440) Quenched and tempered Black oxide finish Heat treated to Rc32	Carbide Black oxide finish

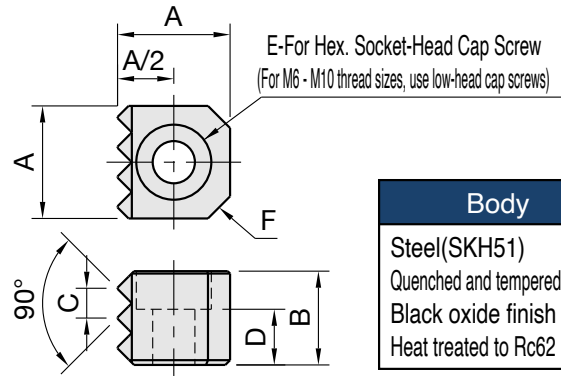

Body
 Steel (SKH51)
 Quenched and tempered
 Black oxide finish
 Heat treated to Rc62

code	A ($\begin{smallmatrix} 0 \\ -0.13 \end{smallmatrix}$)	B ($\begin{smallmatrix} 0 \\ -0.13 \end{smallmatrix}$)	C	D	E	F	Weight (g)
51 99 20 20	10	6	2.3	2.8	M 3	1.6	4
51 99 20 21		10		6.8			6
51 99 20 22	12	6	3	1.9	M 4	2.3	4
51 99 20 23		10		5.9			8
51 99 20 24		12		7.9			10
51 99 20 25	16	6	3	1.8	M 6	3.2	8
51 99 20 26		10		5.8			14
51 99 20 27		12		7.8			17
51 99 20 28		6		0.9			10
51 99 20 29	20	10	3	4.9	M 8	3.2	20
51 99 20 30		12		6.9			25
51 99 20 31		10		3.4			31
51 99 20 32	25	12	3	5.4	M10	3.2	39

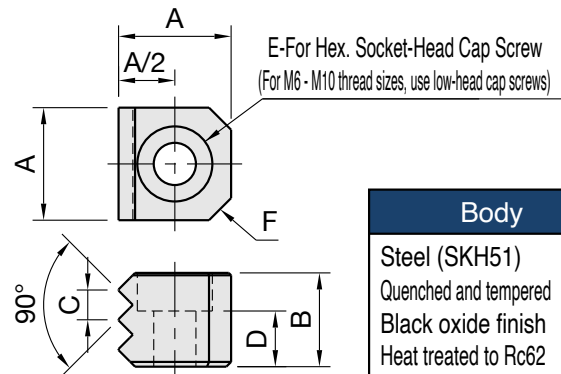
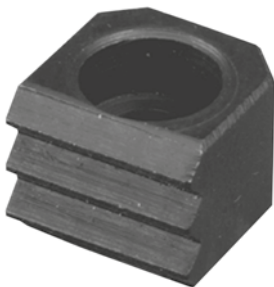

Body
 Steel (SKH51)
 Quenched and tempered
 Black oxide finish
 Heat treated to Rc62

code	A ($\begin{smallmatrix} 0 \\ -0.13 \end{smallmatrix}$)	B ($\begin{smallmatrix} 0 \\ -0.13 \end{smallmatrix}$)	C	D	E	F	Weight (g)
51 99 20 33	10	6	2.3	2.8	M 3	1.6	4
51 99 20 34		10		6.8			6
51 99 20 35	12	6	3	1.9	M 4	2.3	5
51 99 20 36		10		5.9			8
51 99 20 37		12		7.9			10
51 99 20 38	16	6	3	1.8	M 6	3.2	8
51 99 20 39		10		5.8			14
51 99 20 40		12		7.8			18
51 99 20 41		6		0.9			10
51 99 20 42	20	10	3	4.9	M 8	3.2	20
51 99 20 43		12		6.9			25
51 99 20 44		10		3.4			31
51 99 20 45	25	12	3	5.4	M10	3.2	40

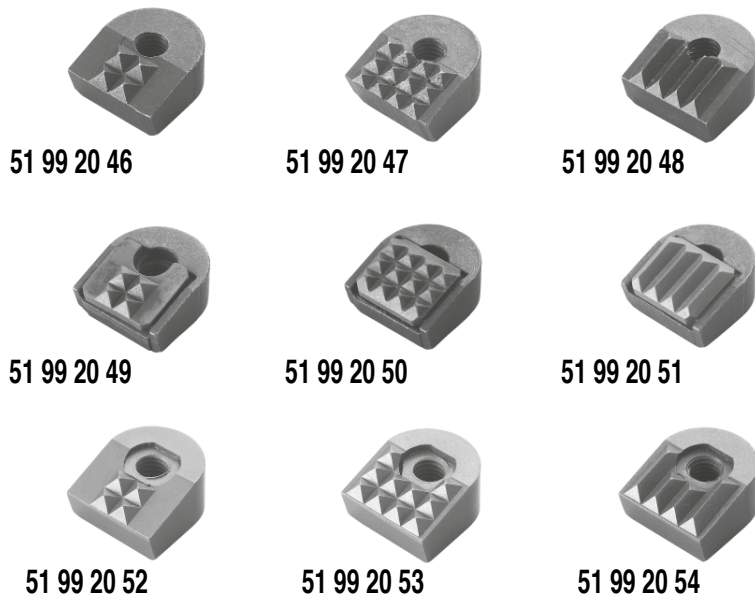

51 99 20 46	Steel (SKH51)	
51 99 20 47	Quenched and tempered	
51 99 20 48	Black oxide finish	
	Heat treated to Rc62	
51 99 20 49	Steel (SKH51)	Carbide Black oxide finish
51 99 20 50	Quenched and tempered	
51 99 20 51	Black oxide finish	
	Heat treated to Rc62	
51 99 20 52	Carbide	
51 99 20 53	Black oxide finish	
51 99 20 54		

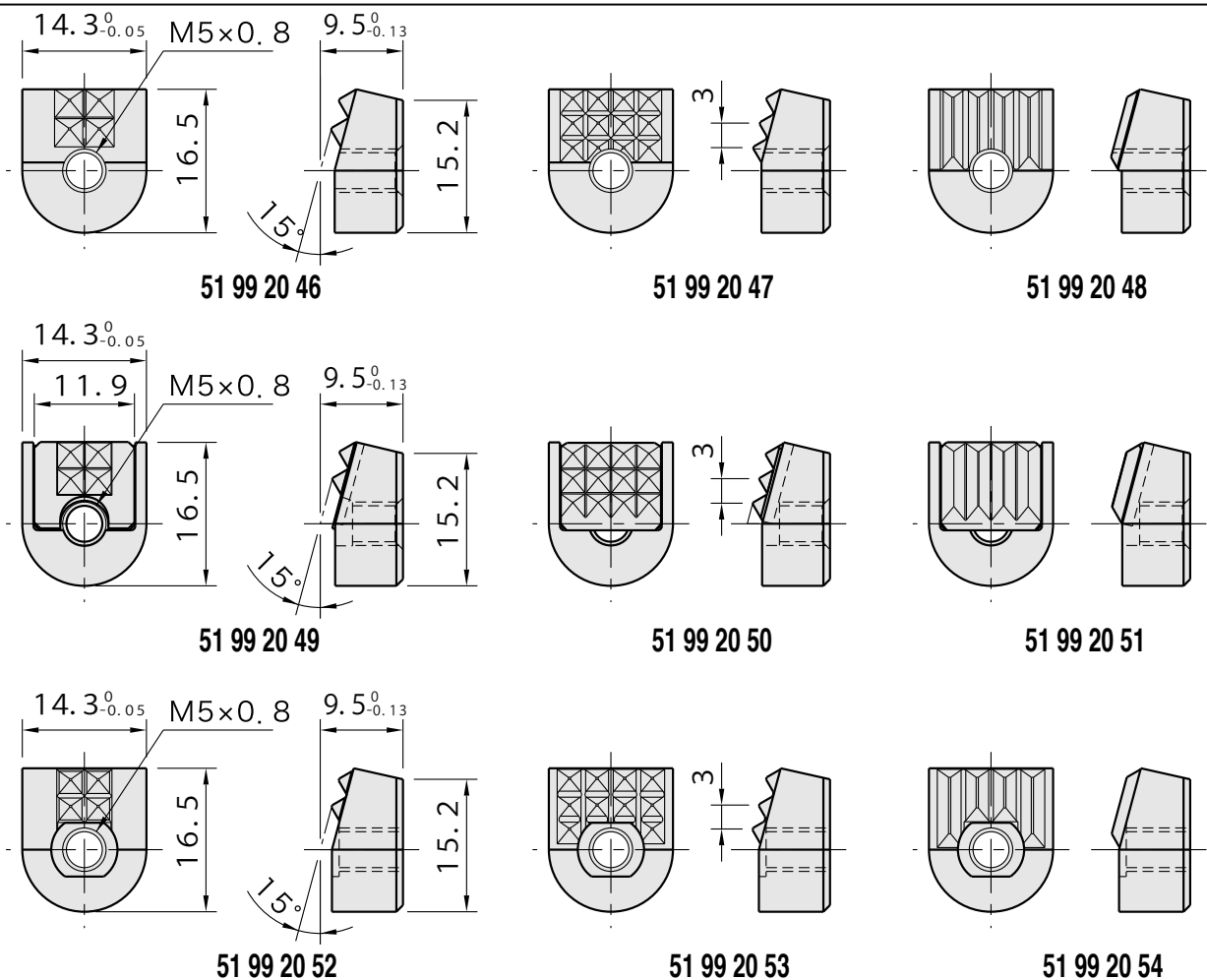

Part Number	Weight (g)
51 99 20 46	11
51 99 20 47	12
51 99 20 48	12

Part Number	Weight (g)
51 99 20 49	12
51 99 20 50	13
51 99 20 51	13

Part Number	Weight (g)
51 99 20 52	20
51 99 20 53	
51 99 20 54	

HS

SOCKET SCREW GRIPPERS

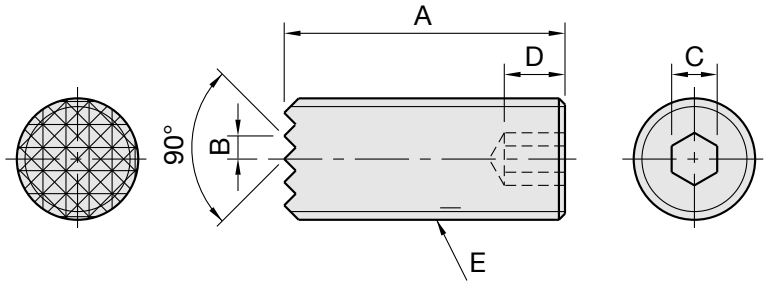

code	A	B	C	D	E	Weight (g)
51 99 20 55	25	2.3	3	4	M10x1.5	13
51 99 20 56	40					21
51 99 20 57	25	3	5	6	M12x1.75	16
51 99 20 58	40					29
51 99 20 59	25	3	6	8	M16x2	34
51 99 20 60	40					53
51 99 20 61	25	3	8	10	M20x2.5	54
51 99 20 62	40					82

Material & Finish
Steel (SKH51) Quenched and tempered Black oxide finish Heat treated to Rc58

PG

TIPPED SOCKET SCREW GRIPPERS

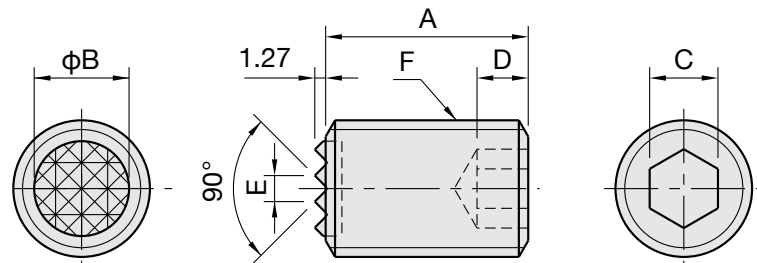

Body	Tip
Steel (SCM440) Quenched and tempered Black oxide finish	Carbide Black oxide finish

code	A	B	C	D	E	F	Weight (g)
51 99 20 63	25	6.4	5	4	2.3	M10x1.5	15
51 99 20 64	50						30
51 99 20 65	25	7.9	6	5	2.3	M12x1.75	21
51 99 20 66	50						43
51 99 20 67	25	11.1	8	6	3	M16x2	37
51 99 20 68	50						77
51 99 20 69	25	12.7	10	8	3	M20x2.5	57
51 99 20 70	50						119

PG

TIPPED SOCKET SCREW GRIPPERS

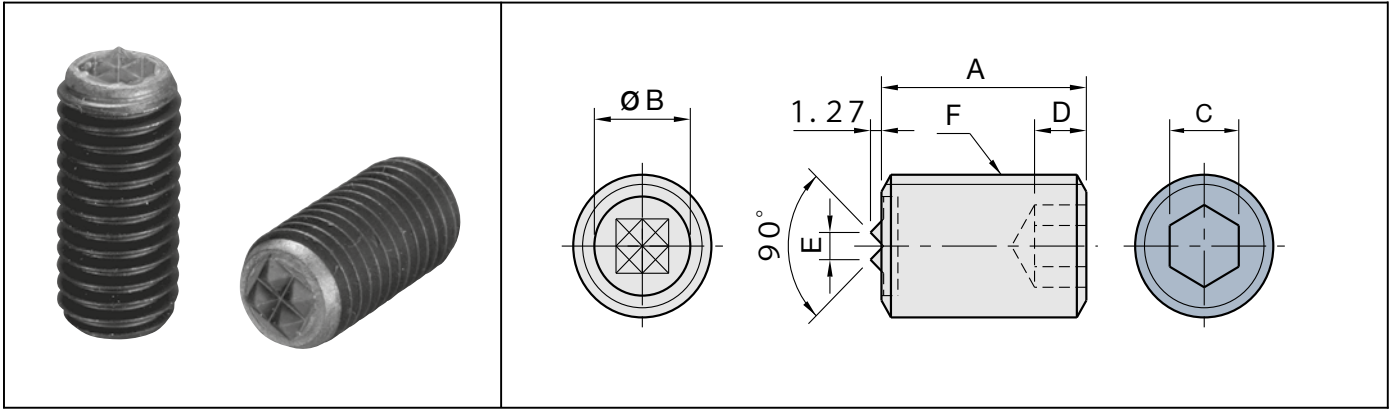

code	A	B	C	D	E	F	Weight (g)
51 99 20 71	25	7.9	6	5	3	M12x1.75	21
51 99 20 72	50						43
51 99 20 73	25	11.1	8	6	3	M16x2	37
51 99 20 74	50						77
51 99 20 75	25	12.7	10	8	3	M20x2.5	57
51 99 20 76	50						119

Steel (SCM440) Quenched and tempered Black oxide finish	Carbide Black oxide finish
--	-------------------------------

CT

HEX-HEAD SCREW GRIPPERS

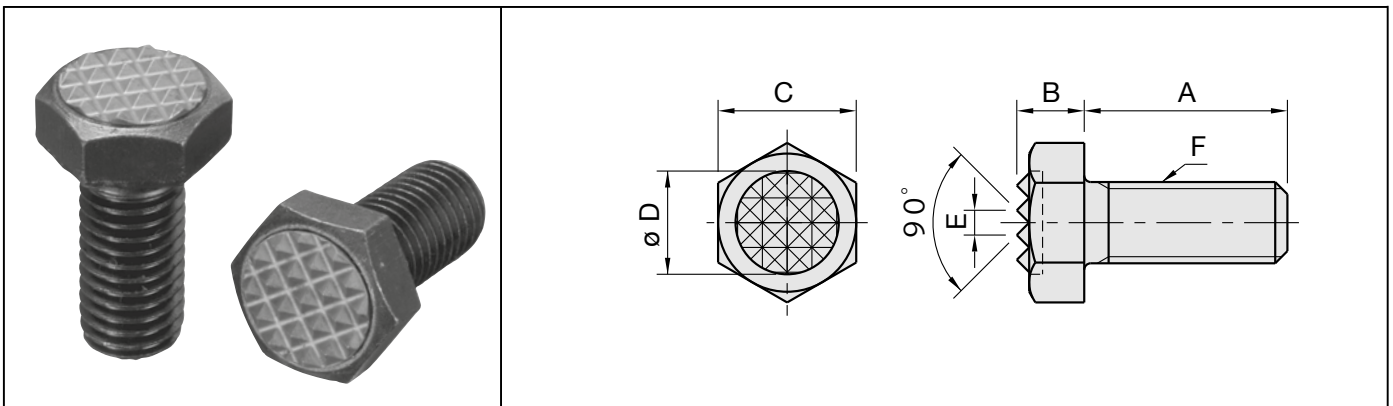

code	A	B	C	D	E	F	Weight (g)
51 99 20 77	12	5	10	7.9	2.3	M 6x1	6
51 99 20 78	25						8
51 99 20 79	12						10
51 99 20 80	25	6.4	13	9.5	3	M 8x1.25	15
51 99 20 81	35						17
51 99 20 82	25	8.3	17	12.7	3	M10x1.25	20
51 99 20 83	12						25
51 99 20 84	25	8.3	17	12.7	3	M10x1.5	27
51 99 20 85	40						36
51 99 20 86	25	8.7	19	15.9	3	M12x1.75	42
51 99 20 87	40						55
51 99 20 88	35	11	24	19.1	3	M16x2	88
51 99 20 89	50						127
51 99 20 90	40	13.5	30	25.4	2.3	M20x2.5	133
51 99 20 91	60						231

Steel (SCM440) Quenched and tempered Black oxide finish Heat treated to Rc32	Carbide Black oxide finish
--	-------------------------------



51 99 20 92 - 20 97
(Serrated, Steel Ball)



51 99 20 98 - 21 11
(Serrated, Steel Tip)



51 99 21 12 - 21 17
(Plain, Steel Ball)



51 99 21 18 - 21 31
(Plain, Steel Tip)



51 99 21 32 - 21 37
(Plain, Plastic Ball)



51 99 21 38 - 21 51
(Plain, Plastic Tip)

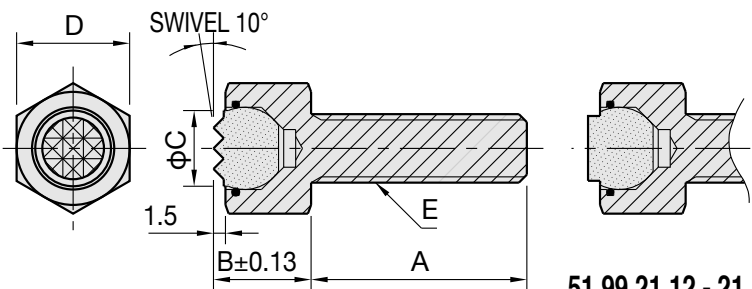

51 99 20 92 - 20 97
(Serrated, Steel Ball)

51 99 21 12 - 21 17
(Plain, Steel Ball)

51 99 21 32 - 21 37
(Plain, Plastic Ball)

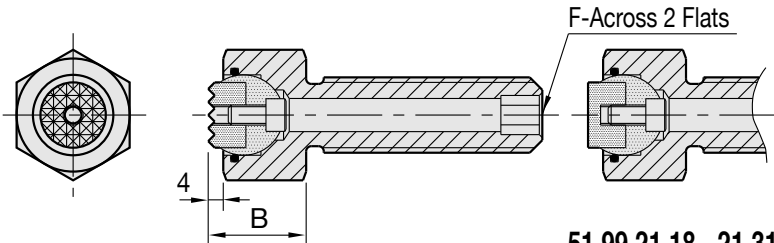

51 99 20 98 - 21 11
(Serrated, Steel Tip)

51 99 21 18 - 21 31
(Plain, Steel Tip)

51 99 21 38 - 21 51
(Plain, Plastic Tip)

code	Body	Ball	Tip
51 99 20 92 - 20 97 51 99 21 12 - 21 17		Steel(SKH51) Quenched and tempered Black oxide finish Heat treated to Rc60	
51 99 21 32 - 21 37	Steel(SCM440)	Polyacetal plastic White	
51 99 20 98 - 21 11	Quenched and tempered		Steel(SKH51) Quenched and tempered Black oxide finish Heat treated to Rc62
51 99 21 18 - 21 31	Black oxide finish	Stainless steel (SUS440)	Steel (SNM220) Carburized-hardened Black oxide finish Heat treated to Rc60
51 99 21 38 - 21 51			Polyacetal plastic White

Serrated (Steel)		Plain (Steel)		Plain (Plastic)		A	B	C	D	E	F	Load Capacity (N)
code	Weight (g)	code	Weight (g)	code	Weight (g)							
51 99 20 92	7	51 99 21 12	7	51 99 21 32	6	12	9.5	6	10	M 6x1	-	5,300
51 99 20 93	8	51 99 21 13	8	51 99 21 33	7	25						
51 99 20 94	10	51 99 21 14	10	51 99 21 34	9	40						
51 99 20 95	12	51 99 21 15	12	51 99 21 35	11	12	13	8.5	13	M 8x1.25	-	10,900
51 99 20 96	18	51 99 21 16	18	51 99 21 36	16	25						
51 99 20 97	22	51 99 21 17	22	51 99 21 37	21	40						
51 99 20 98	26	51 99 21 18	26	51 99 21 38	22	15	17	10	17	M10x1.5	3	18,400
51 99 20 99	33	51 99 21 19	33	51 99 21 39	29	30						
51 99 21 00	43	51 99 21 20	43	51 99 21 40	39	50						
51 99 21 01	55	51 99 21 21	55	51 99 21 41	49	20	19	12	19	M12x1.75	5	24,500
51 99 21 02	65	51 99 21 22	65	51 99 21 42	59	40						
51 99 21 03	75	51 99 21 23	75	51 99 21 43	69	60						
51 99 21 04	87	51 99 21 24	87	51 99 21 44	75	25	23	16	24	M16x2	6	43,600
51 99 21 05	117	51 99 21 25	117	51 99 21 45	105	50						
51 99 21 06	152	51 99 21 26	152	51 99 21 46	140	80						
51 99 21 07	153	51 99 21 27	154	51 99 21 47	134	30	24	20	30	M20x2.5	8	57,700
51 99 21 08	205	51 99 21 28	206	51 99 21 48	186	60						
51 99 21 09	276	51 99 21 29	277	51 99 21 49	257	100						
51 99 21 10	287	51 99 21 30	289	51 99 21 50	257	40	30	25	36	M24x3	10	85,600
51 99 21 11	432	51 99 21 31	434	51 99 21 51	402	100						

Application Example

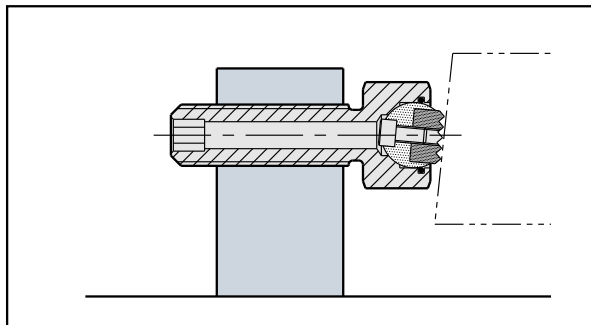

- Ideal for workpiece positioning and positive holding.

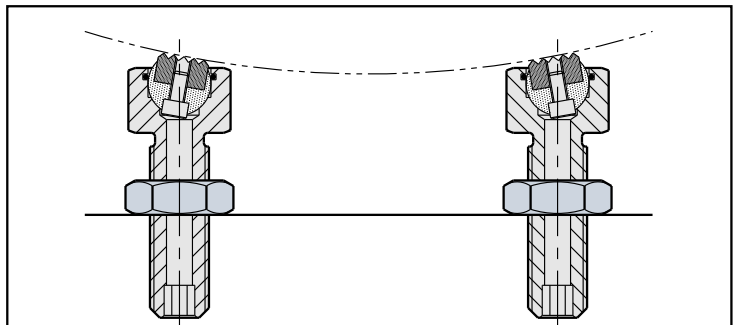

- Can also be used as screw jacks.

How To Install Tip

- Push the ball out of the body and then secure the tip to the ball using the included hex. socket-head cap screw.



51 99 21 52 - 21 57
(Serrated, Steel Ball)



51 99 21 58 - 21 62
(Serrated, Steel Tip)



51 99 21 63 - 21 68
(Plain, Steel Ball)



51 99 21 69 - 21 73
(Plain, Steel Tip)



51 99 21 74 - 21 79
(Plain, Plastic Ball)



51 99 21 80 - 21 84
(Plain, Plastic Tip)

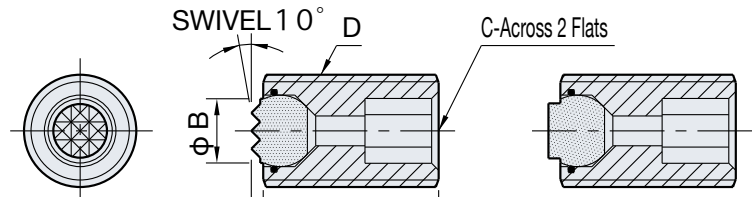

51 99 21 52 - 21 57
(Serrated, Steel Ball)

51 99 21 63 - 21 68
(Plain, Steel Ball)
51 99 21 74 - 21 79
(Plain, Plastic Ball)

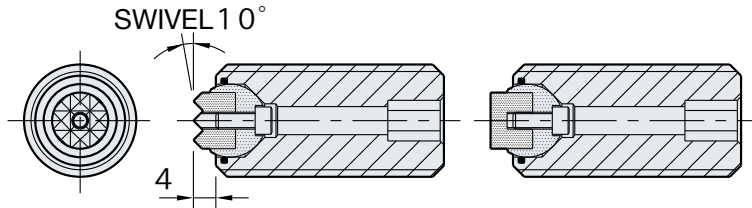

51 99 21 58 - 21 62
(Serrated, Steel Tip)

51 99 21 69 - 21 73
(Plain, Steel Tip)
51 99 21 80 - 21 84
(Plain, Plastic Tip)

code	Body	Ball	Tip
51 99 21 52 - 21 57 51 99 21 63 - 21 68		Steel (SKH51) Quenched and tempered Black oxide finish Heat treated to Rc60	
51 99 21 74 - 21 79		Polyacetal plastic White	
51 99 21 58 - 21 62	Steel (SCM440) Quenched and tempered Black oxide finish Heat treated to Rc45	Stainless steel (SUS440)	Steel (SKH51) Quenched and tempered Black oxide finish Heat treated to Rc62
51 99 21 69 - 21 73			Steel (SNCM220) Carburized-hardened Black oxide finish Heat treated to Rc60
51 99 21 80 - 21 84			Polyacetal plastic White

Serrated (Steel)		Plain (Steel)		Plain (Plastic)		A	B	C	D	Load Capacity (N)
code	Weight (g)	code	Weight (g)	code	Weight (g)					
51 99 21 52	13	51 99 21 63	13	51 99 21 74	12	25	6	6	M12×1.75	5,300
51 99 21 53	19	51 99 21 64	19	51 99 21 75	18	35				
51 99 21 54	28	51 99 21 65	28	51 99 21 76	27	50				
51 99 21 55	26	51 99 21 66	26	51 99 21 77	25	25	8.5	8	M16×2	10,900
51 99 21 56	39	51 99 21 67	39	51 99 21 78	38	35				
51 99 21 57	58	51 99 21 68	58	51 99 21 79	57	50				
51 99 21 58	57	51 99 21 69	57	51 99 21 80	53	30	10	10	M20×2.5	18,400
51 99 21 59	90	51 99 21 70	90	51 99 21 81	86	50				
51 99 21 60	123	51 99 21 71	123	51 99 21 82	119	70				
51 99 21 61	113	51 99 21 72	113	51 99 21 83	107	40	12	10	M24×3	24,500
51 99 21 62	210	51 99 21 73	210	51 99 21 84	204	80				

Application Example TBU

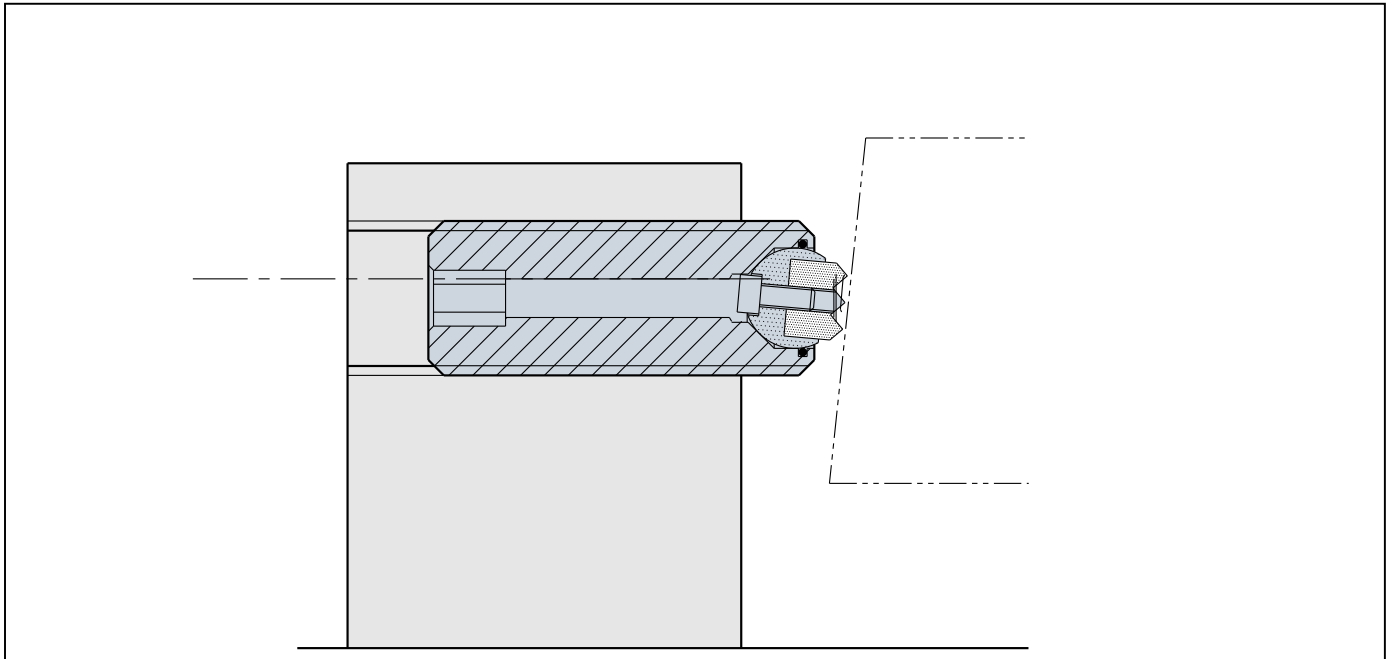

- Ideal for workpiece positioning and positive holding.

How To Install Tip

- Push the ball out of the body and then secure the tip to the ball using the included hex. socket-head cap screw.

Application Example BBU

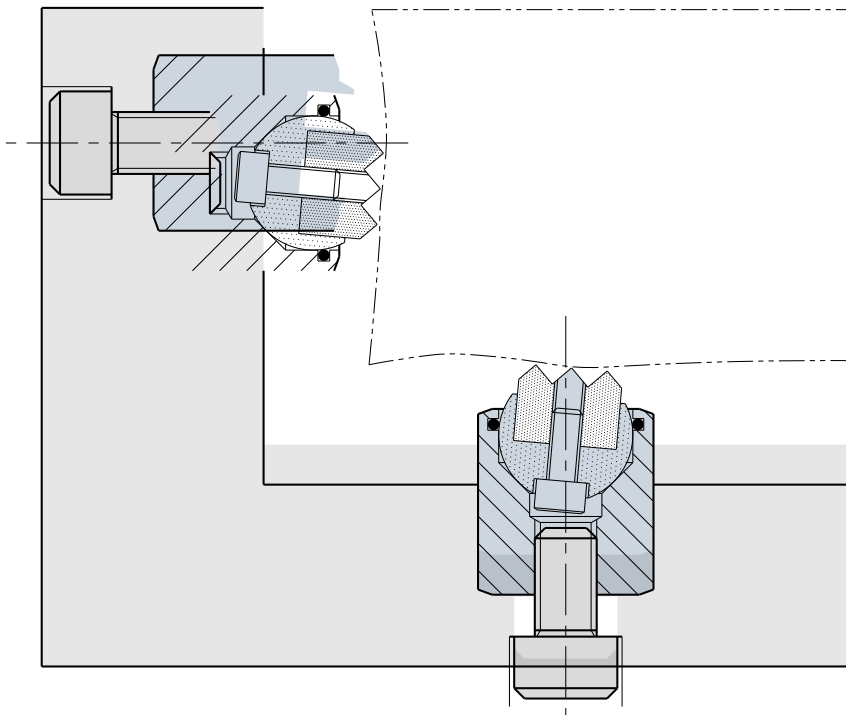

- Grippers for better workpiece positioning methods.

How To Install Tip

- Push the ball out of the body and then secure the tip to the ball using the included hex. socket-head cap screw.



51 99 21 85 - 21 88
(Serrated, Steel Ball)



51 99 21 89 - 21 93
(Serrated, Steel Tip)



51 99 21 94 - 21 97
(Plain, Steel Ball)



51 99 21 98 - 22 02
(Plain, Steel Tip)



51 99 22 03 - 22 06
(Plain, Plastic Ball)



51 99 22 07 - 22 11
(Plain, Plastic Tip)

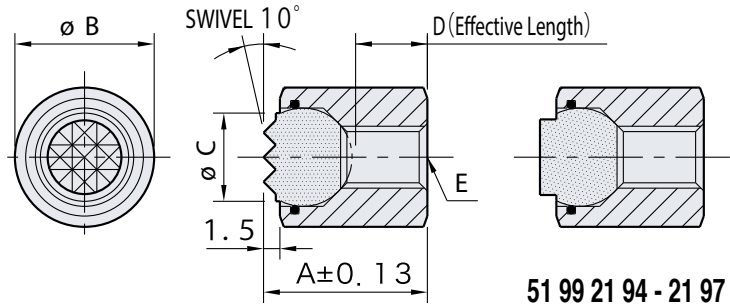

51 99 21 85 - 21 88
(Serrated, Steel Ball)

51 99 21 94 - 21 97
(Plain, Steel Ball)

51 99 22 03 - 22 06
(Plain, Plastic Ball)

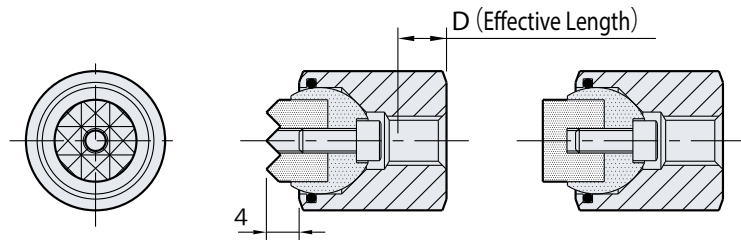

51 99 21 89 - 21 93
(Serrated, Steel Tip)

51 99 21 98 - 22 02
(Plain, Steel Tip)

51 99 22 07 - 22 11
(Plain, Plastic Tip)

code		
51 99 21 85 - 21 88 51 99 21 94 - 21 97		Steel (SKH51) Quenched and tempered Black oxide finish Heat treated to Rc60
51 99 22 03 - 22 06		Polyacetal plastic White
51 99 21 89 - 21 93	Steel (SCM440) Quenched and tempered Black oxide finish	Steel (SKH51) Quenched and tempered Black oxide finish Heat treated to Rc62
51 99 21 98 - 22 02	Stainless steel (SUS440)	Steel (SNCM220) Carburized-hardened Black oxide finish Heat treated to Rc60
51 99 22 07 - 22 11		Polyacetal plastic White

Serrated (Steel)		Plain (Steel)		Plain (Plastic)		A	B	C	D	E	Load Capacity (N)
Part Number	Weight (g)	Part Number	Weight (g)	Part Number	Weight (g)						
51 99 21 85	6	51 99 21 94	6	51 99 22 03	5	12	10	6	3.5	M 4×0.7	5300
51 99 21 86	13	51 99 21 95	13	51 99 22 04	12	25			9		
51 99 21 87	12	51 99 21 96	12	51 99 22 05	11	16	13	8.5	6.5	M 5×0.8	10900
51 99 21 88	21	51 99 21 97	21	51 99 22 06	20	25			9		
51 99 21 89	31	51 99 21 98	31	51 99 22 07	27	22	17	10	7.5	M 6×1	18400
51 99 21 90	43	51 99 21 99	43	51 99 22 08	37	24	19	12	8.5	M 8×1.25	24500
51 99 21 91	72	51 99 22 00	73	51 99 22 09	61	28	24	16	9	M10×1.5	43600
51 99 21 92	128	51 99 22 01	129	51 99 22 10	109	30	30	20	8.5	M12×1.75	57700
51 99 21 93	235	51 99 22 02	237	51 99 22 11	205	36	36	25	12	M12×1.75	85600

