



Standard-Programm

# VOLLHARTMETALL-WERKZEUGE



# INHALT

## 01 Einführung

---

Kompetenz Vollhartmetall-Werkzeuge Bohren und Fräsen .....	4
Programmübersicht Bohren und Fräsen .....	6
Sonderlösungen Bohren und Fräsen .....	8
Wiederaufbereitungsservice .....	12

## 02 Vollbohren

---

Produktübersicht, Auswahlhilfe, Bezeichnungsschlüssel .....	18
Vollbohren .....	
Vollbohren mit Vollhartmetall .....	35
Vollbohren mit Wechselkopfsystem .....	199
Anbohren .....	255
Stufenbohren .....	265
Tiefbohren .....	275
Bohrreiben .....	297

## 03 Fräsen

---

Produktübersicht, Auswahlhilfe, Bezeichnungsschlüssel .....	310
Eckfräser .....	
Universelle Anwendung .....	323
Schruppen .....	381
Schlichten .....	403
Trochoides Fräsen .....	421
Kugel- und Eckradiusfräser .....	445
Fas-, Bohr- und Entgratfräser .....	499

## 04 Technischer Anhang

---

Anwendungshinweise, Handhabungshinweise .....	509
---	-----

# KOMPETENZ VOLLHARTMETALL-WERKZEUGE

Die Miller GmbH & Co. KG, Präzisionswerkzeuge in Altenstadt produziert mit durchschlagendem Erfolg und innovativer Produktionsstrategie Präzisionswerkzeuge zum Bohren und Fräsen aus Vollhartmetall.

Die größten Stärken von MILLER sind das breite Standardprogramm mit anwendungsspezifischen Katalogwerkzeugen sowie die besonders hohe Flexibilität um komplexe und herausragende Sonderwerkzeuge in Vollhartmetall zu realisieren.

Im Standardprogramm spiegeln sich die langjährige Erfahrung, das gesammelte Know-how und das hohe Prozessverständnis von MILLER im Bereich Vollhartmetall-Werkzeuge wider. Prozesssicherheit, Effizienz und höchste Produktivität für Kunden sind damit garantiert.

Nach umfassender Forschungs- und Entwicklungsarbeit, konstruiert und simuliert mit neuster Software, produziert und geprüft auf modernsten Fertigungseinrichtungen, gelangen Bohrer und Fräser von MILLER zum Kunden. In Verbindung mit den jeweils leistungsfähigsten Schneidstoffen bietet MILLER so das optimale Werkzeug für nahezu alle Anwendungen und Werkstoffe.



## Für alle Anwendungen

Für jede Bearbeitung bietet MILLER das passende Werkzeug. Alle Bearbeitungsarten – ob allgemeine wie Nutfräsen, Planfräsen, Eckfräsen, zum Anbohren und Vollbohren oder spezielle wie trochoides oder Helixfräsen, sowie Bohreiben und Tiefbohren werden mit innovativen Werkzeuglösungen abgedeckt.

## Für jeden Werkstoff

Neben der Art der Bearbeitung ist der Werkstoff das wichtigste Auswahlkriterium für das passende Werkzeug. Das Programm von MILLER umfasst neben Werkzeugen zur Bearbeitung von Stahl, Guss und Aluminium auch Lösungen zum wirtschaftlichen und prozesssicheren Bearbeiten von Titan, Superlegierungen, Kunststoffen und Verbundwerkstoffen.

## Sonderlösungen

Spezielle Bearbeitungsaufgaben erfordern besondere Werkzeuge. Deshalb bietet MILLER Werkzeuge in Sonderausführung, individuell auf die Anforderungen des Kunden zugeschnitten.

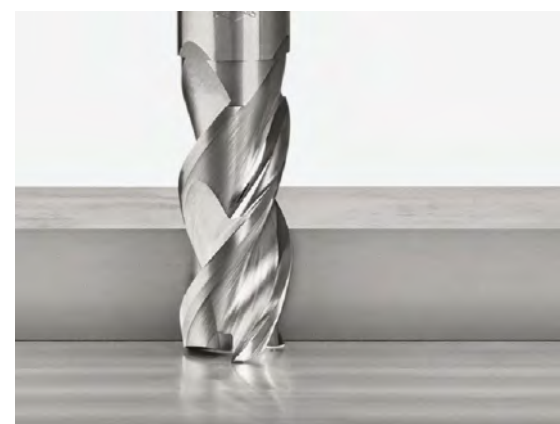



### Leistungsfähige Beschichtungen

Für die Standzeit des Werkzeugs und optimale Bearbeitungsergebnisse ist die Beschichtung der Schneiden ein entscheidendes Kriterium. MILLER bietet eine große Auswahl an Substraten und Beschichtungen, jeweils auf den vorliegenden Bearbeitungsfall abgestimmt.

### Modernste Fertigungseinrichtungen

Modernste 3D-Konstruktion und Simulationen bilden die Grundlage für die Fertigung der MILLER Werkzeuge. Die Daten werden über Schnittstellen an das jeweilige Bearbeitungszentrum im modernen und umfangreichen Maschinenpark übergeben. Überwacht und kontrolliert von erfahrenen Mitarbeitern entstehen so die MILLER Werkzeuge für höchste Qualitätsanforderungen.

### Wiederaufbereitung in Originalqualität

Durch die Wiederaufbereitung von Vollhartmetallwerkzeugen mit Originalschliff und Originalbeschichtung können nochmals fast 100 Prozent der Standzeit von neuen Werkzeugen erreicht werden. Für eine schnelle Abwicklung übernimmt MILLER auf Wunsch das Abholen und Anliefern der Werkzeuge.



# PROGRAMM- ÜBERSICHT



## Vollbohren

- 1 Vollbohren mit Vollhartmetall (ab Seite 35)
- 2 Vollbohren mit Wechselkopfsystem (ab Seite 199)
- 3 Anbohren (ab Seite 255)
- 4 Stufenbohren (ab Seite 265)
- 5 Tiefbohren (ab Seite 275)
- 6 Bohrreihen (ab Seite 297)

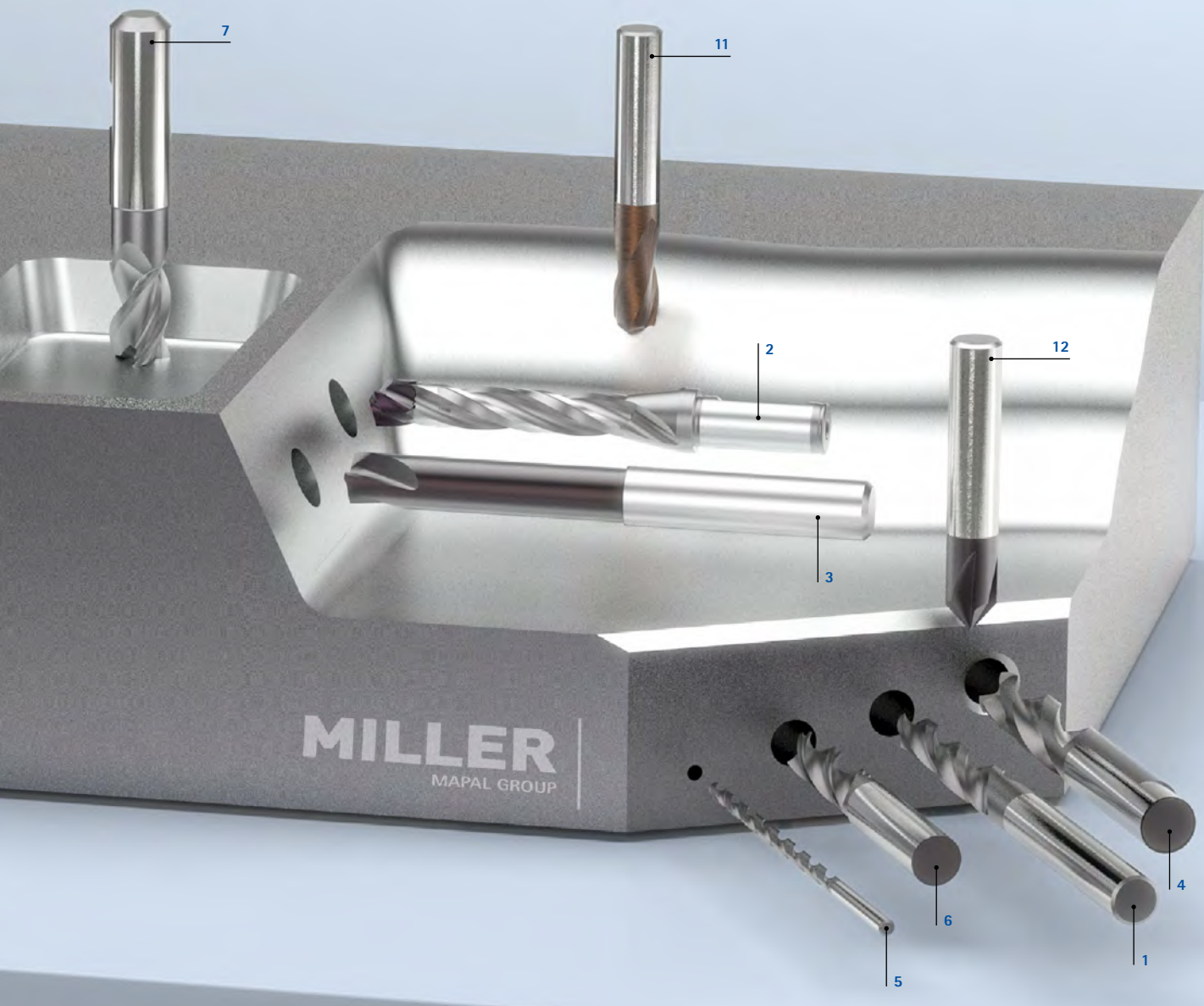

## Fräsen

**7** Universelle Anwendung (ab Seite 323)

**8** Schruppen (ab Seite 381)

**9** Schlichten (ab Seite 403)

**10** Trochoides Fräsen (ab Seite 421)

**11** Kugel- und Eckradiusfräser (ab Seite 445)

**12** Fas-, Bohr- und Entgratfräser (ab Seite 499)

# SONDERLÖSUNGEN

## Vollbohren mit Vollhartmetall



MILLER bietet neben einem umfangreichen Standardprogramm an Bohrwerkzeugen auch Sonderwerkzeuge an.

Individuelle Kundenanforderungen verlangen nach Sonderlösungen, die speziell auf die Bearbeitungsaufgaben zugeschnitten sind. Mit dem großen Know-how in der Metallbearbeitung und der langjährigen Erfahrung ist MILLER weltweit der kompetente Partner, wenn es um die Konstruktion und die Fertigung von Sonderwerkzeugen sowie die Auslegung von kompletten Zerspanungsprozessen für die Bohrungsbearbeitung geht. Das Programm umfasst spiralisierte und gerade genutete Bohrer sowie Stufenbohrer aus Vollhartmetall und PKD-bestückte Bohrer.

**MILLER - der Partner wenn es um anwendungsspezifische Sonderlösungen geht.**



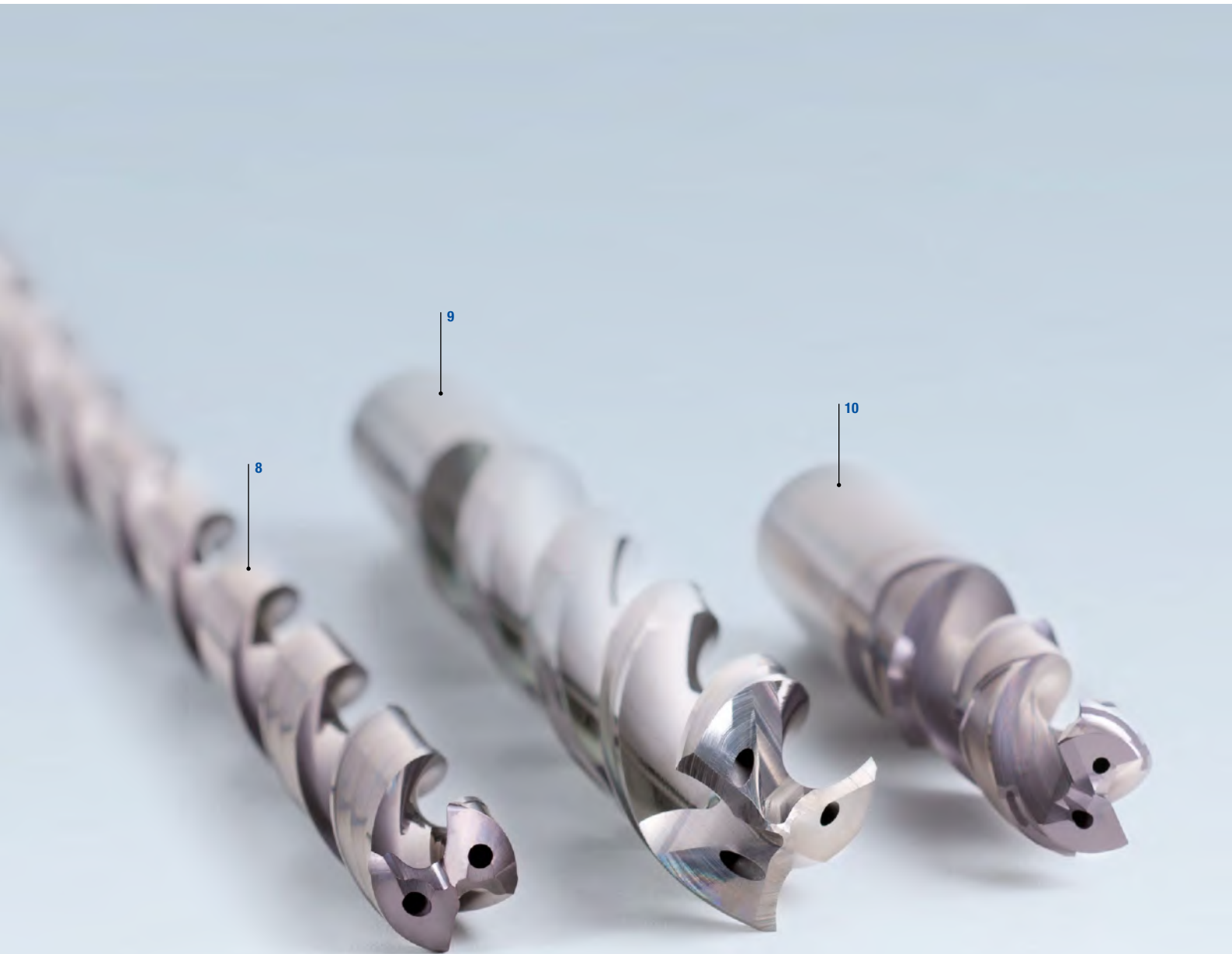

### Sonderwerkzeuge zum Bohren von MILLER

- 1 VHM-Sonder-Stufenbohrer mit drei Schneiden, selbstzentrierende Querschneide, für die Pleuelbearbeitung in einem Schuss
- 2 VHM-Stufenbohrer mit drei Führungsfasen und spezieller Beschichtung für die Hochgeschwindigkeitsbearbeitung
- 3 VHM-Kernlochbohrer für die Pleuelbearbeitung im zweistufigen Prozess
- 4 VHM-Stufenbohrer mit drei Führungsfasen und spezieller Beschichtung für die Hochgeschwindigkeitsbearbeitung von Achsschenkelgelenken aus ADI 900
- 5 VHM-Sonderbohrer mit Tritan-Drill-Geometrie und spezieller Beschichtung für die Turboladerbearbeitung
- 6 Bohrreibahle mit drei Schneiden und zusätzlichen Reibschneiden am Umfang mit spezieller Beschichtung für die Bearbeitung von Achsen aus GJS
- 7 VHM-Pilotbohrer für die Pleuelbearbeitung im zweistufigen Prozess
- 8 VHM-Tiefbohrer mit Sonderbeschichtung zur Bearbeitung von Zylinderblöcken aus GJV
- 9 VHM-Aluminiumbohrer mit drei Schneiden, selbstzentrierender Querschneide und hochglanzpolierten Spannuten für die Bearbeitung von AISi1
- 10 VHM-Stufenbohrer mit 180°-Stirnanschliff für die Ventilbearbeitung

# SONDERLÖSUNGEN

## Schafffräser mit festen Schneiden

MILLER bietet neben einem umfangreichen Standardprogramm an Schafffräsern mit festen Schneiden auch Sonderfräser an, die speziell auf die jeweiligen Bearbeitungsaufgaben zugeschnitten sind. Dabei können komplexe Geometrien und Konturen für hochgenaue und flexible Fertigungsmöglichkeiten realisiert werden. Selbst außergewöhnliche Werkzeugkonzepte für die Zusammenlegung von Bearbeitungsschritten oder Kombinationsbearbeitungen können kurzfristig umgesetzt werden – vom komplexen Formfräser bis hin zum Scheibenfräser aus Vollhartmetall.





### Anwendungsbeispiele für Sonderfräser

- 1 VHM-Sonder-Schaftfräser, fünf Schneiden, Spezialbeschichtung und radiale Kühlmittelaustritte in der Spannüt. Anwendung bei der Bearbeitung von PKW-Lenkgehäusen aus AlSi9Cu3.
- 2 VHM-Sonder-Schaftfräser, fünf Schneiden, linksspiralisiert mit speziellem Schruppprofil für die Bearbeitung von PKW-Heckklappen.
- 3 VHM-Sonder-Formfräser, vier Schneiden, spezielle Ungleichteilung mit erodierter Formstufe. Optimierung der Bearbeitung eines Lagerträgers aus AlSi1.
- 4 VHM-Sonder-Scheibenfräser, 16 Schneiden, eng tolerierte Kontur der Formschneiden. Anwendung bei der Bearbeitung von Automobilscharnieren aus S355J2.
- 5 VHM-Sonder-Ringnutfräser, vier Schneiden, gerade genutet – Formfräser mit erodierten Umfangsschneiden. Bearbeitung der Kraftstoffzuführung eines Common Rail Gehäuses.
- 6 VHM-Sonder-Kugelfräser, vier Schneiden für das Entgraten von Radträgern aus AlMgSi1.
- 7 VHM-Sonder-Formfräser, vier Schneiden, Prismen- und Radiusform. Bearbeitung des Brennraumes eines Zylinderkopfes aus Aluminium.
- 8 Wechselkopf-Kugelbahnfräser für die Weich- und Hartbearbeitung homokinetischer Gelenke im Antriebstrang. Für das Hartfräsen kommen PcBN-bestückte Werkzeuge mit HSK-Halter zum Einsatz.

# WIEDERAUFBEREITUNGS- SERVICE WELTWEIT

Egal, wo auf der Welt Sie produzieren: Sie können sicher sein, dass Sie vor Ort von unseren Services zur Wiederaufbereitung Ihrer Werkzeuge in Original MILLER Qualität profitieren.



**WELTWEIT EINHEITLICHE  
QUALITÄTSSTANDARDS**



**FERTIGUNG UND WIEDERAUFBEREITUNG VON WERKZEUGEN  
AUS EINER HAND**



**WIEDERAUFBEREITUNG WELTWEIT MIT  
IDENTISCHEN  
MASCHINEN UND SOFTWARE**



**ANSPRECHPARTNER  
IN JEDEM LAND**



**SERVICE VOR ORT  
AUCH BEI KOMPLEXEN WERKZEUGSYSTEMEN**



EINFACHE, SCHNELLE UND PÜNKTLICHE  
**ABWICKLUNG**



**HOCHWERTIGE**  
BETRIEBSMITTEL, SCHLEIFSCHEIBEN, ETC.



ABDECKUNG ALLER PRODUKTIONSSTANDORTE DURCH  
**LOKALE SERVICEZENTREN**



QUALIFIZIERTES, GEZIELT  
**TRAINIERTES SERVICEPERSONAL**  
WELTWEIT

# WIEDERAUFBEREITUNG IN MILLER QUALITÄT

Innerhalb kürzester Zeit erhalten Sie nach einer Wiederaufbereitung bei MILLER Ihre Werkzeuge in bester Qualität zurück. Damit es noch schneller geht, übernehmen wir auf Wunsch auch das Abholen und Anliefern Ihrer Werkzeuge.



## Wiederaufbereitung von MILLER Werkzeugen oder Fremdwerkzeugen



Durch Wiederaufbereitung Ihrer Werkzeuge in Original MILLER Qualität erreichen Sie nochmals fast 100% der Standzeit von neu gekauften Werkzeugen. Das spart Kosten.

- Nachschleifen und Beschichten
- Nacherodieren
- Neubestückung mit Schneidplatten oder Fräseinsätzen
- Austausch von Verschleißteilen
- Aufchromen und Nachschleifen von Schäften
- Messprotokoll-Service



**SICHERE VERPACKUNG**

auf Wunsch in MILLER Toolbox für sicheren Hin- und Rücktransport.

**PROMPTE ABHOLUNG**

und schneller, kostengünstiger Transport durch MILLER Fahrservice oder Paketdienst.

**DETAILLIERTE VORABPRÜFUNG**

auf Wunsch im Hinblick darauf, ob sich die Wiederaufbereitung lohnt.

**ORIGINALNACHSCHLIFF**

durch qualifiziertes Fachpersonal auf modernsten Maschinen.

**ORIGINALBESCHICHTUNG**

stellt eine Standzeit sicher, die vergleichbar ist mit Neuwerkzeugen.

**EXAKTE QUALITÄTSPRÜFUNG**

mit neuester Messtechnik in MILLER Qualität.

**SCHNELLE RÜCKLIEFERUNG**

auf dem schnellsten Weg per MILLER Fahrservice oder Paketdienst.

**65% KOSTENEINSPARUNG**

bei viermaliger Wiederaufbereitung eines MILLER Spiralbohrers aus Vollhartmetall mit Hochleistungsbeschichtung.

# VOLLBOHREN

---

Optimale Bohrer für nahezu alle Anwendungen und Werkstoffe.







# PRODUKTÜBERSICHT

Zum Vollbohren bietet MILLER ein umfangreiches Standardprogramm für nahezu alle Bearbeitungsaufgaben bestehend aus Vollhartmetallbohrern sowie Wechselkopfbohrern. Das Programm umfasst Universalbohrer sowie Werkzeuge zur Bearbeitung von Guss, Nichteisenmetallen, Stählen, Leichtbau- oder schwer zu zerspanenden Werkstoffen. Zudem sind Lösungen zur Hochgeschwindigkeits- und Hochvorschubbearbeitung mit drei Schneiden Teil des Angebots.

Auch die Vollhartmetall- und die Wechselkopfbohrer können individuell angepasst werden. Für alle Werkzeuge garantiert der weltweite Nachschleifservice in Originalqualität höchste Wirtschaftlichkeit.





**Basic Line:**  
Universalwerkzeuge, breites Anwendungsgebiet, niedrige Anschaffungskosten





**Performance Line:**  
Hochleistungswerkzeuge, breites Anwendungsgebiet, hohe Produktivität in der Serienfertigung



**Expert Line:**  
Spezialistenwerkzeuge für ausgewählte Anwendungen, maximale Präzision und Produktivität

Vollbohrer	Anbohrer
	
<p><b>Vollbohren mit Vollhartmetall</b></p> <p>Vollbohrer aus Vollhartmetall für nahezu alle Werkstoffe in drei unterschiedlichen Leistungsklassen.</p> <ul style="list-style-type: none"> <li>- <b>MEGA-Drill</b> - Zweischneidige Vollbohrer mit abgestimmter Beschichtung und Geometrie auf den jeweiligen Werkstoff</li> <li>- <b>Tritan-Drill</b> - Dreischneidige Vollbohrer für höchsten Vorschub mit selbstzentrierender Querschneide für schwierige Bohrsituationen</li> <li>- <b>ECU-Drill</b> - Extrem wirtschaftliche Programmauswahl mit sehr gutem Preis-Leistungs-Verhältnis</li> </ul> <p>Ø-Bereich: 0,50 - 25,00 mm Bohrtiefe: 3xD 4xD 5xD 6xD 8xD 12xD</p> <p><b>P M K N C S H</b></p>	<p><b>Vollbohren mit Wechselkopfsystem</b></p> <p>Vollbohren mit minimiertem Hartmetalleinsatz bei höchster Stabilität und Präzision.</p> <ul style="list-style-type: none"> <li>- <b>Schneidplattenbohrer EXD</b> - Wirtschaftliches System mit austauschbaren Schneidplatten</li> <li>- <b>Wechselkopfbohrer TTD</b> - Zweischneidiger Wechselkopfbohrer mit fünf verschiedenen Bohrköpfen</li> <li>- <b>Wechselkopfbohrer TTD-Tritan</b> - Bis zu doppelter Vorschub gegenüber zweischneidigen Wechselkopfbohrern. Hohe Prozesssicherheit und Stabilität auch bei schwierigen Bohrsituationen</li> </ul> <p>Ø-Bereich: 9,00 - 50,00 mm Bohrtiefe: 1xD 1,5xD 3xD 5xD</p> <p><b>P M K N C S H</b></p>
<p>Seite 35</p>	<p>Seite 199</p>
	<p><b>Anbohren</b></p> <p>Herstellung von Zentrierbohrungen nach DIN.</p> <ul style="list-style-type: none"> <li>- <b>Tritan-Spot-Drill</b> - Dreischneidiger Anbohrer für anspruchsvolle Anbohrsituationen, speziell abgestimmt auf dreischneidige Bohrer</li> <li>- <b>ECU-Centre-Drill</b> - Herstellung DIN-gerechte Zentrierbohrungen in rotationssymmetrischen Bauteilen</li> </ul> <p>Ø-Bereich: 0,50 - 20,00 mm</p> <p><b>P M K S</b></p>
<p>Seite 255</p>	



Stufenbohrer	Tiefbohrer	Bohrreibahle
		
<p><b>Stufenbohren</b></p> <p>Herstellung von Kernlöchern und Anfasungen für metrische Gewinde.</p> <ul style="list-style-type: none"> <li>- <b>Tritan-Step-Drill</b> – Dreischneidiger Stufenbohrer mit selbstzentrierender Querschneide für die Bearbeitung von Gewindekernlöchern ohne Pendelbewegung</li> <li>- <b>MEGA-Step-Drill</b> – Zweischneidiger Stufenbohrer für die Herstellung von Gewindekernlöchern</li> </ul> <p><b>Ø-Bereich:</b> 2,50 - 17,50 mm</p> <p><b>P M</b></p>	<p><b>Tiefbohren</b></p> <p>Prozesssichere und effiziente Herstellung tiefer Bohrungen bis 40xD.</p> <ul style="list-style-type: none"> <li>- <b>MEGA-Deep-Drill</b> – Tiefbohrer mit Innenkühlung für die prozesssichere Bearbeitungen tiefer Bohrungen bis 40xD</li> <li>- <b>MEGA-Pilot-Drill</b> – Pilotbohrer speziell auf MEGA-Deep-Drill abgestimmt</li> </ul> <p><b>Ø-Bereich:</b> 1,00 - 16,00 mm  <b>Bohrtiefe:</b>                  12xD 20xD 25xD 30xD 40xD</p> <p><b>P M K N</b></p>	<p><b>Bohrreiben</b></p> <p>Bohren und Reiben in einem Arbeitsgang.</p> <p><b>Tritan-Drill-Reamer:</b></p> <ul style="list-style-type: none"> <li>- Genaute Lösung zum Bohrreiben</li> <li>- Drei Schneiden und sechs Führungsfasen</li> <li>- Selbstzentrierende Querschneide für verbessertes Anbohrverhalten</li> <li>- Hohe Positionsgenauigkeit</li> <li>- Optimale Rundheit</li> <li>- Mit Innenkühlung</li> <li>- Toleranzausführungen ±0,003 mm und H7</li> </ul> <p><b>Ø-Bereich:</b> 3,80 - 20,05 mm  <b>Bohrtiefe:</b>                  3xD 5xD</p> <p><b>P K N</b></p>
<p>Seite 265</p>	<p>Seite 275</p>	<p>Seite 297</p>

# BAUREIHENÜBERSICHT

## Vollbohren mit Vollhartmetall

# MEGA-BOHRER

Zweischneidige Vollbohrer mit abgestimmter Beschichtung und Geometrie auf den jeweiligen Werkstoff.



## MEGA-Drill

- Auf jeden Werkstoff individuell abgestimmte Beschichtung und Geometrie
- Breites Anwendungsfeld
- Beinhaltet Tiefbohrer, Stufen- und Microbohrer für jeden Anwendungsfall

Produktklasse:

Perfor-  
mance  
LINE

Materialeigung:

P M K  
N C S H

Bohrtiefe:

3xD 4xD  
5xD 8xD 12xD

Ø-Bereich: 0,50 - 25,00 mm



## MEGA-Speed-Drill

- Hochgeschwindigkeitsbohrer mit zwei Schneiden
- Feinstgeschliffenes Nutprofil für schnelle Spanabfuhr
- Drei Führungsfasen vermindern Reibung und Vibration

Produktklasse:

Expert  
LINE

Materialeigung:

P M  
K S

Bohrtiefe:

3xD 5xD  
8xD 12xD

Ø-Bereich: 3,00 - 20,00 mm



## MEGA-Quadro-Drill

- Vier Führungsfasen für maximale Bohrungsqualität, Koaxialität und Positionsgenauigkeit
- Optimale Rundheit und Durchmesser-toleranzen

Produktklasse:

Perfor-  
mance  
LINE

Materialeigung:

P  
K

Bohrtiefe:

5xD  
8xD 12xD

Ø-Bereich: 3,00 - 20,00 mm



## MEGA-180°-Drill

- Vollbohren mit ebenem Bohrungsgrund
- Anbohren an geneigten Flächen bis 45°

Produktklasse:

Expert  
LINE

Materialeigung:

P M  
K N

Bohrtiefe:

3xD  
5xD

Ø-Bereich: 3,00 - 20,00 mm



# TRITAN-BOHRER

Dreischneidige Vollbohrer für höchsten Vorschub mit selbstzentrierender Querschneide für schwierige Bohrsituationen.



# ECU-BOHRER

Extrem wirtschaftliche Programmauswahl mit sehr gutem Preis-Leistungs-Verhältnis.



## Tritan-Drill

- Robuste Werkzeuge mit stabilen Schneidecken
- Keine Pendelbewegungen bei der Bearbeitung
- Optimale Spanabfuhr



Produktklasse:



Materialeignung:



Bohrtiefe:

3xD	5xD
8xD	12xD

Ø-Bereich: 4,00 - 20,00 mm

## ECU-Drill

- Wirtschaftliche Programmauswahl
- Schneidstoff und Beschichtungen speziell auf Werkstoff abgestimmt



Produktklasse:



Materialeignung:



Bohrtiefe:

3xD	4xD	5xD
6xD	8xD	12xD

Ø-Bereich: 3,00 - 20,00 mm

# AUSWAHL EINES BOHRERS

## Schritt für Schritt zum richtigen Bohrer

Sie suchen zum Beispiel einen Vollbohrer für die Bearbeitung von gehärtetem Stahl?  
Diese Auswahlhilfe führt Sie Schritt für Schritt zum richtigen Bohrer.

1	<b>Anwendung</b>	Wählen Sie Ihre Hauptanwendung.	➤		Vollbohren		Anbohren
2	<b>Design</b>	Wählen Sie Ihre bevorzugte Werkzeugausführung.	➤		Monolithisch		Trennstelle QTS
3	<b>Produktklasse</b>	Entscheiden Sie sich für eine Produktklasse.	➤	 <b>Basic Line:</b> Universalwerkzeuge, breites Anwendungsgebiet, niedrige Anschaffungskosten			
4	<b>Materialeignung</b>	Bestimmen Sie Ihren Werkstückstoff gemäß den MILLER Zerspanungsgruppen (MZG). Die MZG finden Sie auf der Klappseite am Ende des Katalogs.	➤		Stahl		Rostfreier Stahl
5	<b>Bauteilmerkmale</b>	Prüfen Sie die Anforderungen, die durch die Bohreigenschaften an Ihr Werkzeug gestellt werden.	➤		Hochvorschubbearbeitung		Hochgeschwindigkeitsbearbeitung
			➤		Erreichbare Bohrungstoleranz $\geq IT$		Vorzugsbaureihe in H7
6	<b>Ausführung</b>	Überprüfen Sie, ob die Geometriemerkmale Ihren Anforderungen entsprechen.	➤	Durchmesserbereich	Schneidenanzahl		
7	<b>Produkt</b>	Wählen Sie Ihren Bohrer. Produkte der lagerhaltigen Vorzugsbaureihe sind kurzfristig lieferbar während Produkte mit konfigurierbaren Merkmalen innerhalb vorgegebener Grenzen frei konfiguriert werden können.	➤	 Lagerhaltige Vorzugsbaureihe			





Stufenbohren



Tiefbohren



Bohrreiben



Trennstelle  
TTS



**Performance Line:**  
Hochleistungswerkzeuge, breites Anwendungsgebiet, hohe Produktivität in der Serienfertigung



**Expert Line:**  
Spezialistenwerkzeuge für ausgewählte Anwendungen, maximale Präzision und Produktivität



Gusseisen



Nichteisenmetalle und Kunststoffe

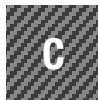

Verbundwerkstoffe



Superlegierungen und Titan



Gehärteter Stahl und Stahlguss



Paketbohren



Querbohren



Schräger Bohrungseintritt



Schräger Bohrungsaustritt



Ebener Bohrungsgrund  
180°



Maximale Bohrtiefe

Anzahl Führungsfasen



Kühlmittelzufuhr



Produkt mit konfigurierbaren Merkmalen

VOLLHARTMETALL-WERKZEUGE | Vollbohren 25

Schritt 1: Anwendung Schritt 2: Design Schritt 3: Produktklasse Schritt 4: Materialeignung Schritt 5: Bauteilmerkmale Schritt 6: Ausführung

Ausführung				Produkt		
Ø [mm]	z	n <sub>FF</sub>		Produktname	Spezifikation	Seite
3 - 25	2	2	✓	MEGA-Drill-Steel-Plus	M2003P, M2103P	57
2 - 20	2	2	✓	MEGA-Drill-Inox	M1703, M1803	135
2,8 - 20	2	2	✓	MEGA-Drill-Alu	M2803	161
2,55 - 20	2	2	✓	MEGA-Drill-Hardened	M1603	88
0,5 - 12	2	2	✓	MEGA-Drill-Composite-MD	M1985, M2925	166

*Note: Blue arrows in the original image point from '6' to the 'z' column and from '7' to the 'Produktname' column.*

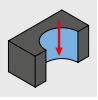

# Vollbohren (1/2)

Design	Produkt-klasse	Materialeignung						Bohrungseigenschaft							Bohrtiefe										
		P	M	K	N	C	S	H	HFC	HSC	180°	Toleranz	3xD	4xD	5xD	6xD	8xD	12xD							
Performance LINE		■		■				■				✓	✓					IT9	✓		✓		✓		
		■	■	■	■		■												IT9	✓		✓		✓	
					■														IT9	✓		✓		✓	✓
								■											IT9		✓				
					■	■													IT9			✓			
		■	■	■															IT9			✓		✓	✓
		■		■											✓				IT9			✓		✓	✓
	Expert LINE		■	■	■	■				✓		✓	✓	✓	✓				IT9			✓		✓	✓
			■	■	■					✓		✓	✓	✓	✓				IT9	✓		✓		✓	✓
						■				✓		✓	✓	✓	✓				IT9			✓			
			■	■	■						✓								IT9	✓		✓		✓	
			■	■	■			■			✓								IT9			✓		✓	✓
		■		■						✓								IT9			✓				
				■						✓								IT9			✓				
							■			✓								IT9			✓				
		■	■	■										✓				IT9	✓		✓				
				■											✓			IT9	✓		✓				
							■											IT9			✓				
Basic LINE			■	■	■														IT9		✓		✓		
		■		■														IT9	✓		✓		✓	✓	
				■	■													IT9			✓		✓		



Schritt 1:  
Anwendung

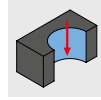

Schritt 2:  
Design



Schritt 3:  
Produktklasse



Schritt 4:  
Materialeignung



Schritt 5:  
Bauteilmerkmale



Schritt 6:  
Ausführung



Ausführung					Produkt			
∅ [mm]	z	η <sub>FF</sub> *		Produktname	Spezifikation		Seite	
3 - 25	2	2	✓	MEGA-Drill-Steel-Plus	M2003P, M2005P, M2103P, M2105P, M2108P		57	
2 - 20	2	2	✓	MEGA-Drill-Inox	M1703, M1705, M1803, M1805, M1808		135	
2,8 - 20	2	2	✓	MEGA-Drill-Alu	M2803, M2805, M2808, M2812		161	
2,55 - 20	2	2		MEGA-Drill-Hardened	M1603		88	
0,5 - 12	2	2		MEGA-Drill-Composite-MD	M1985, M2925		166	
0,8 - 2,99	2	2	✓	MICRO-Drill-Steel	M1925, M1928, M1932		85	
3 - 20	2	4	✓	MEGA-Quadro-Drill-Plus	M2075P, M2175P, M2178P, M2182P		76	
4 - 20	3	3	✓	Tritan-Drill-Uni-Plus	M9535P, M9538P, M9542P		36	
4 - 20	3	3	✓	Tritan-Drill-Steel	M9933, M9935, M9938, M9942		91	
4 - 20	3	3	✓	Tritan-Drill-Alu	M9835		159	
3 - 20	2	3	✓	MEGA-Speed-Drill-Uni	M9103, M9105, M9108		42	
3 - 20	2	3	✓	MEGA-Speed-Drill-Steel	M9923, M9925, M9928, M9932		101	
3 - 20	2	3	✓	MEGA-Speed-Drill-Inox	M9405, M9408, M9412		148	
3 - 20	2	3	✓	MEGA-Speed-Drill-Iron	M9505		156	
3 - 20	2	4	✓	MEGA-Speed-Drill-Titan	M9605		157	
3 - 20	2	4	✓	MEGA-180°-Drill	M9183, M9185		111	
3 - 20	2	4	✓	MEGA-180°-Drill-Alu	M9883, M9885		172	
3 - 12	2	2		MEGA-Drill-Composite-UDX	M2915, M2935		168	
3 - 12	2	2		MEGA-Drill-Aramid	M2993		170	
3 - 20	2	2	✓	ECU-Drill-Uni	M6804, M6704, M6806		48	
3 - 20	2	2	✓	ECU-Drill-Steel	M6103, M6003, M6105, M6005, M6108, M6112		117	
4,8 - 11,6	2	4	✓	ECU-G-Drill	M2605, M2608		176	

Fortsetzung auf nächster Seite.

\* η<sub>FF</sub> = Anzahl der Führungsfasen

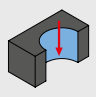

# Vollbohren (2/2)

Design	Produkt-klasse	Materialeignung						Bohrungseigenschaft							Bohrtiefe									
		P	M	K	N	C	S	H	HFC	HSC	1	2	3	4	5	180°	Toleranz	1xD	1,5xD	3xD	5xD	8xD	12xD	
Performance LINE	Performance LINE	■		■													IT9	✓		✓	✓	✓	✓	
		■		■													IT9	✓		✓	✓	✓	✓	
		■	■	■	■		■										IT9	✓		✓	✓	✓	✓	
					■												IT9	✓		✓	✓	✓	✓	
						■											IT9	✓		✓	✓	✓	✓	
																	IT9			✓	✓	✓		
Expert LINE	Expert LINE	■		■					✓		✓	✓	✓	✓		IT9			✓	✓	✓			
		■		■												IT10		✓	✓	✓	✓	✓		
		■		■												IT10		✓	✓	✓	✓	✓		
		■		■												IT10		✓	✓	✓	✓	✓		
		■	■	■	■		■									IT10		✓	✓	✓	✓	✓		
					■											IT10		✓	✓	✓	✓	✓		
Performance LINE	Performance LINE				■										IT10		✓	✓	✓	✓	✓			
															IT10		✓	✓	✓	✓	✓			
															IT10		✓	✓	✓	✓	✓			
		■	■	■	■		■								IT10		✓	✓	✓	✓	✓			
					■										IT10		✓	✓	✓	✓	✓			
						■									IT10		✓	✓	✓	✓	✓			

■ bestens geeignet

□ bedingt geeignet

Schritt 1:  
Anwendung

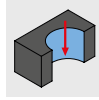

Schritt 2:  
Design



Schritt 3:  
Produktklasse



Schritt 4:  
Materialeignung















Schritt 5:  
Bauteilmerkmale

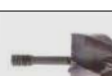

Schritt 6:  
Ausführung



Ausführung					Produkt			
∅ [mm]	z	η <sub>FF</sub> *		Produktname	Spezifikation		Seite	
12 - 45	2	4	✓	Wechselbohrkopf TTD Uni-Plus	01P-Uni-Plus		222	
12 - 45	2	3	✓	Wechselbohrkopf TTD Steel	04-Steel		223	
12 - 45	2	3	✓	Wechselbohrkopf TTD Inox	02-Inox		225	
12 - 45	2	4	✓	Wechselbohrkopf TTD Iron	05-Iron		227	
12 - 45	2	4	✓	Wechselbohrkopf TTD Alu	03-Alu		228	
12 - 32,49	3	3	✓	Wechselbohrkopf TTD-Tritan Uni	01-Uni		246	
9 - 50	2	2	✓	Schneidplatte EXD Steel	01-Steel		202	
14 - 32	2	2	✓	Schneidplatte EXD Steel-Pyramid	05-Pyramid		204	
10 - 33	2	2	✓	Schneidplatte EXD Uni, Form EK	10-Uni		206	
9 - 50	2	2	✓	Schneidplatte EXD Inox	02-Inox		207	
9 - 50	2	2	✓	Schneidplatte EXD Iron	04-Iron		209	
9 - 50	2	2	✓	Schneidplatte EXD Alu	03-Alu		210	

\* η<sub>FF</sub> = Anzahl der Führungsfasen

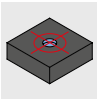

## Anbohren

Design	Produkt-klasse	Materialeignung						Bohrungseigenschaft							Bohrtiefe					
		P	M	K	N	C	S	H	HFC	HSC	180°	Toleranz	1xD	1,5xD	3xD	5xD	8xD	12xD		
	Expert LINE	■	■	■	■	■	■	■												
	Basic LINE	■	■	■	■	■	■	■												

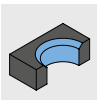

## Stufenbohren

Design	Produkt-klasse	Materialeignung						Bohrungseigenschaft							Bohrtiefe					
		P	M	K	N	C	S	H	HFC	HSC	180°	Toleranz	1xD	1,5xD	3xD	5xD	8xD	12xD		
	Expert LINE	■	■	■	■	■	■	■	✓											
	Performance LINE	■	■	■	■	■	■	■												



## Tiefbohren

Design	Produkt-klasse	Materialeignung						Bohrungseigenschaft							Bohrtiefe				
		P	M	K	N	C	S	H	HFC	HSC	180°	Toleranz	15xD	20xD	25xD	30xD	40xD		
	Performance LINE	■	■	■	■	■	■	■											
	Performance LINE	■	■	■	■	■	■	■			✓	IT9	✓	✓	✓	✓	✓		
	Performance LINE	■	■	■	■	■	■	■			✓	IT9		✓	✓	✓	✓		

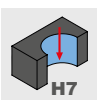

## Bohrreiben

Design	Produkt-klasse	Materialeignung						Bohrungseigenschaft							Bohrtiefe					
		P	M	K	N	C	S	H	HFC	HSC	180°	Toleranz	1xD	1,5xD	3xD	5xD	8xD	12xD		
	Expert LINE	■	■	■	■	■	■	■			✓	IT7			✓	✓				

■ bestens geeignet

□ bedingt geeignet

Schritt 1:  
Anwendung

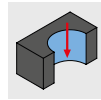

Schritt 2:  
Design



Schritt 3:  
Produktklasse



Schritt 4:  
Materialeignung



Schritt 5:  
Bauteilmerkmale



Schritt 6:  
Ausführung



Ausführung					Produkt			
∅ [mm]	z	η <sub>FF</sub> *			Produktname	Spezifikation		Seite
4 - 20	3	0			Tritan-Spot-Drill-Steel	M9930		256
0,5 - 2,5	2	2			ECU-Centre-Drill	M1200		258

Ausführung					Produkt			
∅ [mm]	z	η <sub>FF</sub> *			Produktname	Spezifikation		Seite
3,98 - 17,50	3	3	✓		Tritan-Step-Drill-Steel	M9913		266
2,5 - 14	2	2	✓		MEGA-Step-Drill-Steel-Plus	M2303P, M2403P		268

Ausführung					Produkt			
∅ [mm]	z	η <sub>FF</sub> *			Produktname	Spezifikation		Seite
1 - 3	2	2	✓		MEGA-Pilot-Drill	M2413		276
1 - 16	2	4	✓		MEGA-Deep-Drill	M2115, M2120, M2125, M2130, M2140		277
3 - 12	2	4	✓		MEGA-Deep-Drill-Alu	M2815, M2820, M2825, M2830, M2840		286

Ausführung					Produkt			
∅ [mm]	z	η <sub>FF</sub> *			Produktname	Spezifikation		Seite
3,80 - 20,05	3		✓		Tritan-Drill-Reamer	M9963, M9965		300

\* η<sub>FF</sub> = Anzahl der Führungsfasen

# Bezeichnungsschlüssel

## Vollhartmetallbohrer

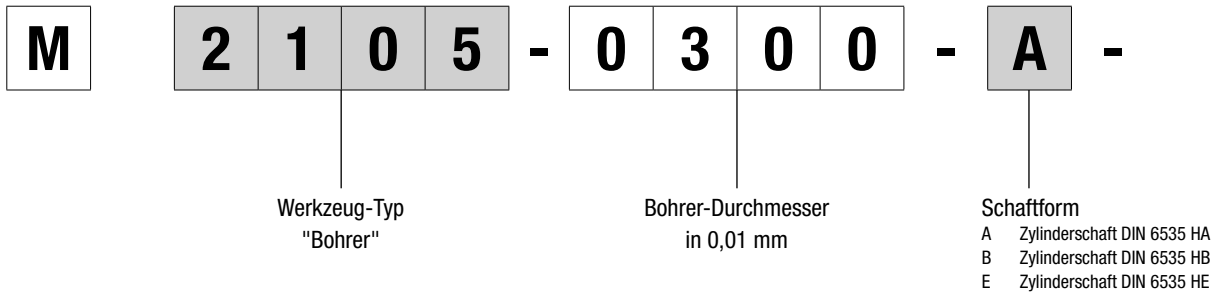

## Wechselsystem EXD und TTD

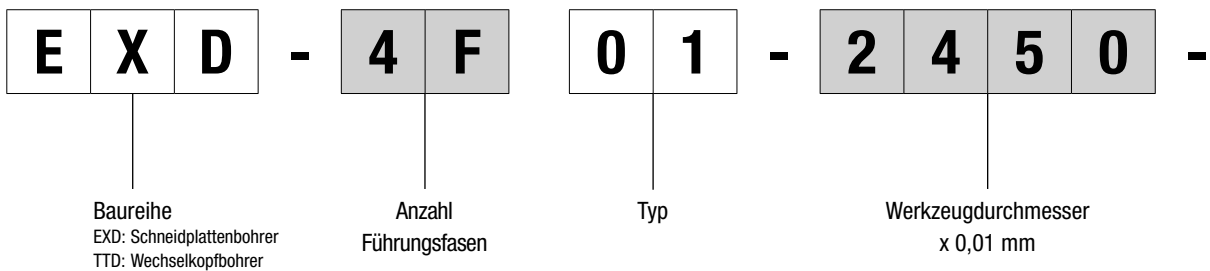

## Halterprogramm TTS für TTD

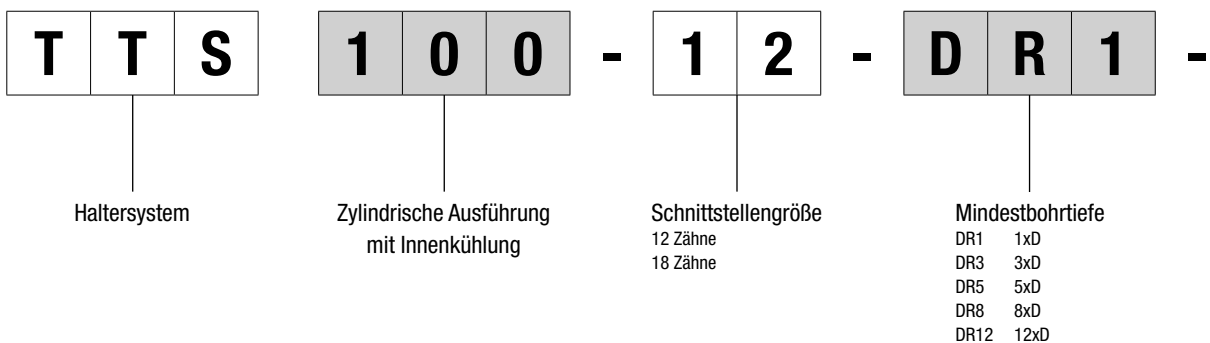

**E**

**Beschichtung**

A	Mx11	M	MxH	V	Mx5
E	MxF   Mx8	P	MxM	W	Mx4
H	MxA	Q	Diamant-Beschichtung	Weitere Beschichtungen auf Anfrage.	
J	MxB	R	MxP		
K	Mx2	U	Unbeschichtet		

**M x F**

**Beschichtung**

MxF	Standard Typ 01/02
MxA	Standard Typ 03
MxP	Standard Typ 04
MxM	Standard Typ 05
Weitere Beschichtungen auf Anfrage.	

**1 2 0 0**

Bohrerdurchmesser  
in 0,1 mm

-

**2 5**

Schaftdurchmesser  
in mm

-

**H A**

**Schaftform**

A	Zylinderschaft DIN 6553 HA
B	Zylinderschaft DIN6553 HB
E	Zylinderschaft DIN6553 HE

# Bezeichnungsschlüssel

## Halterprogramm EXS für EXD

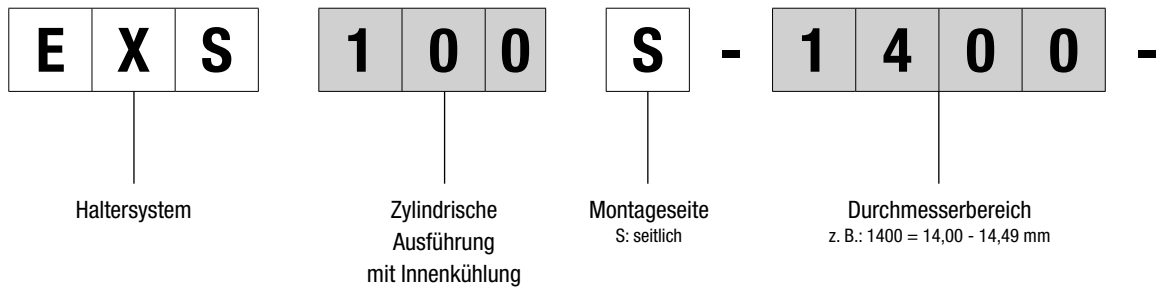

## Wechselsystem TTD-Tritan

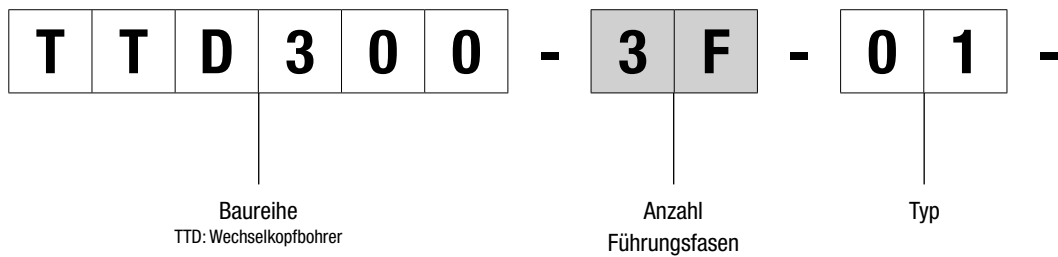

## Halterprogramm TTS für TTD-Tritan

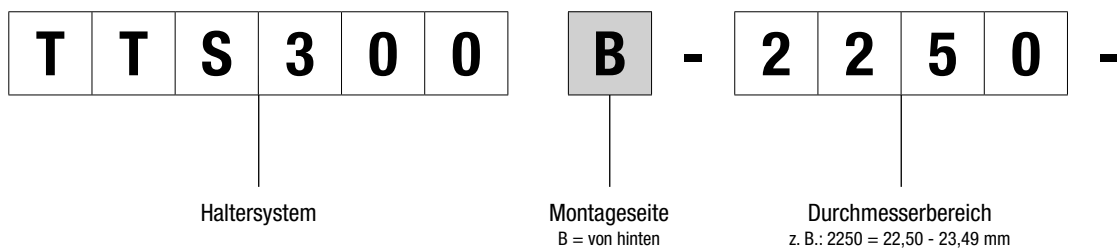



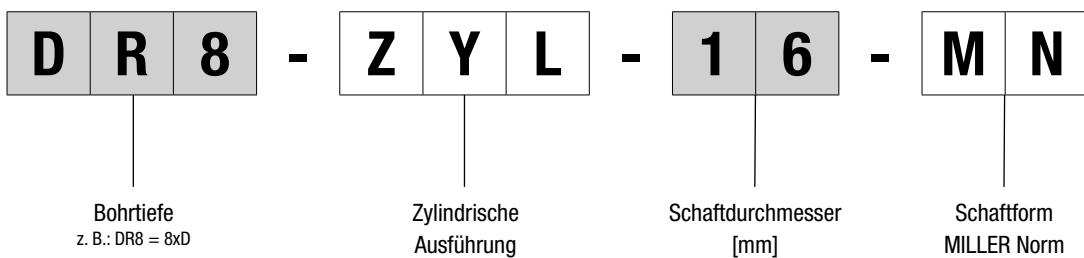
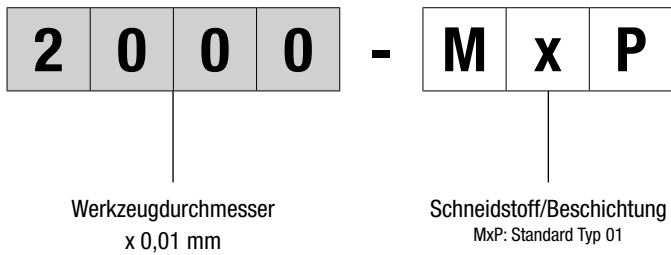
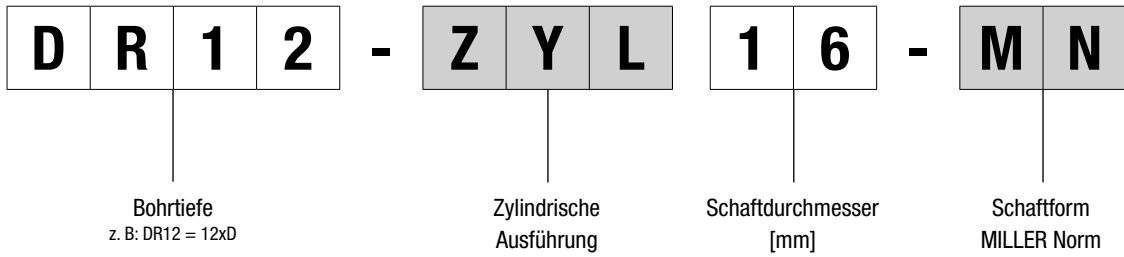



# VOLLBOHREN MIT VOLLHARTMETALL

## Universeller Einsatz

---

Tritan-Drill-Uni-Plus .....	36
MEGA-Speed-Drill-Uni .....	42
ECU-Drill-Uni .....	48

## Stahl und gehärteter Stahl

---

MEGA-Drill-Steel-Plus .....	57
MEGA-Quadro-Drill-Plus .....	76
MICRO-Drill-Steel .....	85
MEGA-Drill-Hardened .....	88
Tritan-Drill-Steel .....	91
MEGA-Speed-Drill-Steel .....	101
MEGA-180°-Drill .....	111
ECU-Drill-Steel .....	117

## Inox und Gusseisen

---

MEGA-Drill-Inox .....	135
MEGA-Speed-Drill-Inox .....	148
MEGA-Speed-Drill-Iron .....	156
MEGA-Speed-Drill-Titan .....	157

## Aluminium und Verbundwerkstoffe

---

Tritan-Drill-Alu .....	159
MEGA-Drill-Alu .....	161
MEGA-Drill-Composite-MD .....	166
MEGA-Drill-Composite-UDX .....	168
MEGA-Drill-Aramid .....	170
MEGA-180°-Drill-Alu .....	172
ECU-G-Drill .....	176

## Technischer Anhang

---

Schnittwertempfehlung .....	178
-----------------------------	-----



# Tritan-Drill-Uni-Plus

Vollhartmetall-Spiralbohrer

M9535P (5xD), innere Kühlmittelzufuhr, Nachfolgeprodukt des Tritan-Drill-Uni (M9535)

**Ausführung:**

Bohrerdurchmesser: 4,00 – 20,00 mm  
 Bohrungstoleranz: IT 9 (erreichbar)  
 Beschichtung: MxP  
 Schneidanzahl: 3  
 Anzahl Führungsfasen: 3  
 Spitzenwinkel: 140°  
 Spiralwinkel: 30°

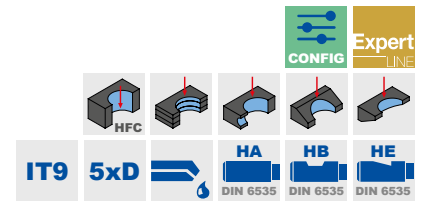
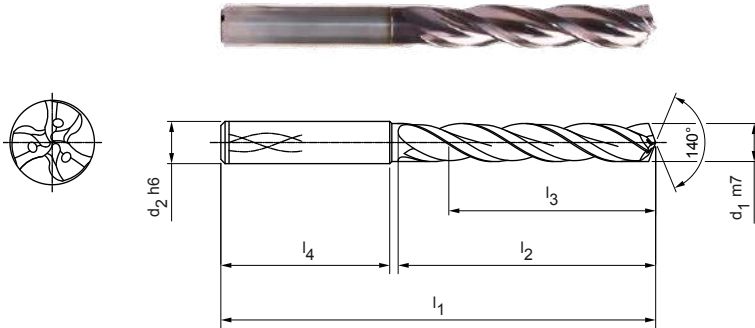

**Lagerhaltige Vorzugsbaureihe in Schaftform HA**

Baumaße						Schaftform HA	
d <sub>1</sub> m7	d <sub>2</sub> h6	l <sub>1</sub>	l <sub>2</sub>	l <sub>3</sub>	l <sub>4</sub>	Spezifikation	Bestell-Nr.
4,00	6	74	36	29	36	M9535P-0400AR	31006315
4,10	6	74	36	29	36	M9535P-0410AR	31006305
4,20	6	74	36	29	36	M9535P-0420AR	31006306
4,30	6	74	36	29	36	M9535P-0430AR	31006307
4,50	6	74	36	29	36	M9535P-0450AR	31006309
4,80	6	82	44	35	36	M9535P-0480AR	31006322
5,00	6	82	44	35	36	M9535P-0500AR	31006324
5,10	6	82	44	35	36	M9535P-0510AR	31006325
5,20	6	82	44	35	36	M9535P-0520AR	31006326
5,30	6	82	44	35	36	M9535P-0530AR	31006327
5,50	6	82	44	35	36	M9535P-0550AR	31006329
5,55	6	82	44	35	36	M9535P-0555AR	31006330
5,60	6	82	44	35	36	M9535P-0560AR	31006331
5,70	6	82	44	35	36	M9535P-0570AR	31006332
5,80	6	82	44	35	36	M9535P-0580AR	31006333
5,90	6	82	44	35	36	M9535P-0590AR	31006334
6,00	6	82	44	35	36	M9535P-0600AR	31006335
6,10	8	91	53	43	36	M9535P-0610AR	31006336
6,20	8	91	53	43	36	M9535P-0620AR	31006337
6,30	8	91	53	43	36	M9535P-0630AR	31006338
6,40	8	91	53	43	36	M9535P-0640AR	31006339
6,50	8	91	53	43	36	M9535P-0650AR	31006340
6,70	8	91	53	43	36	M9535P-0670AR	31006342
6,80	8	91	53	43	36	M9535P-0680AR	31006343
6,90	8	91	53	43	36	M9535P-0690AR	31006344
7,00	8	91	53	43	36	M9535P-0700AR	31006345
7,40	8	91	53	43	36	M9535P-0740AR	31006349
7,50	8	91	53	43	36	M9535P-0750AR	31006350
7,70	8	91	53	43	36	M9535P-0770AR	31006352
7,80	8	91	53	43	36	M9535P-0780AR	31006353
7,90	8	91	53	43	36	M9535P-0790AR	31006354
8,00	8	91	53	43	36	M9535P-0800AR	31006355
8,10	10	103	61	49	40	M9535P-0810AR	31006356
8,50	10	103	61	49	40	M9535P-0850AR	31006360
8,60	10	103	61	49	40	M9535P-0860AR	31006361

## Tritan-Drill-Uni-Plus | Vollhartmetall-Spiralbohrer M9535P (5xD), innere Kühlmittelzufuhr

Baumaße						Schaftform HA	
d <sub>1</sub> m7	d <sub>2</sub> h6	l <sub>1</sub>	l <sub>2</sub>	l <sub>3</sub>	l <sub>4</sub>	Spezifikation	Bestell-Nr.
8,80	10	103	61	49	40	M9535P-0880AR	31006363
9,00	10	103	61	49	40	M9535P-0900AR	31006365
9,30	10	103	61	49	40	M9535P-0930AR	31006368
9,50	10	103	61	49	40	M9535P-0950AR	31006370
9,80	10	103	61	49	40	M9535P-0980AR	31006373
9,90	10	103	61	49	40	M9535P-0990AR	31006374
10,00	10	103	61	49	40	M9535P-1000AR	31006376
10,20	12	118	71	56	45	M9535P-1020AR	31006378
10,50	12	118	71	56	45	M9535P-1050AR	31006381
11,00	12	118	71	56	45	M9535P-1100AR	31006386
11,20	12	118	71	56	45	M9535P-1120AR	31006388
11,50	12	118	71	56	45	M9535P-1150AR	31006391
11,70	12	118	71	56	45	M9535P-1170AR	31006393
11,80	12	118	71	56	45	M9535P-1180AR	31006394
12,00	12	118	71	56	45	M9535P-1200AR	31006396
12,50	14	124	77	60	45	M9535P-1250AR	31006397
13,00	14	124	77	60	45	M9535P-1300AR	31006399
13,50	14	124	77	60	45	M9535P-1350AR	31006400
13,80	14	124	77	60	45	M9535P-1380AR	31006401
14,00	14	124	77	60	45	M9535P-1400AR	31006402
14,50	16	133	83	63	48	M9535P-1450AR	31006403
14,80	16	133	83	63	48	M9535P-1480AR	31006404
15,00	16	133	83	63	48	M9535P-1500AR	31006405
15,50	16	133	83	63	48	M9535P-1550AR	31006406
16,00	16	133	83	63	48	M9535P-1600AR	31006408
17,00	18	143	93	71	48	M9535P-1700AR	31006411
17,50	18	143	93	71	48	M9535P-1750AR	31006412
18,00	18	143	93	71	48	M9535P-1800AR	31006414
18,50	20	153	101	77	50	M9535P-1850AR	31006415
19,80	20	153	101	77	50	M9535P-1980AR	31006419
20,00	20	153	101	77	50	M9535P-2000AR	31006420

## Konfigurierbare Merkmale

**Durchmesser:**

Durchmesser in Abstufungen  
von 0,01 mm frei wählbar

**Schaftform:**

Schaftform: HB | HE

**Spezifikation:**

M9535P-[Durchmesser][Schaftform]R

## Abmessungen konfigurierbare Baureihe

d <sub>1</sub> min.	d <sub>1</sub> max.	d <sub>2</sub> h6	l <sub>1</sub>	l <sub>2</sub>	l <sub>3</sub>	l <sub>4</sub>
4,00	4,70	6	74	36	29	36
4,71	6,00	6	82	44	35	36
6,01	8,00	8	91	53	43	36
8,01	10,00	10	103	61	49	40
10,01	12,00	12	118	71	56	45
12,01	14,00	14	124	77	60	45
14,01	16,00	16	133	83	63	48
16,01	18,00	18	143	93	71	48
18,01	20,00	20	153	101	77	50

**Beispiel:**  
M9535P-0431ER

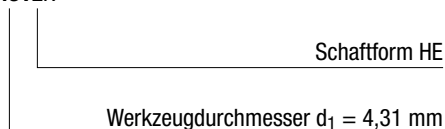

Maßangaben in mm.

Schnittwertempfehlung siehe Kapitelende.

Sonderausführungen und andere Beschichtungen auf Anfrage.

# Tritan-Drill-Uni-Plus

Vollhartmetall-Spiralbohrer

M9538P (8xD), innere Kühlmittelzufuhr, Nachfolgeprodukt des Tritan-Drill-Uni (M9538)

**Ausführung:**

Bohrerdurchmesser: 4,00 – 20,00 mm  
 Bohrungstoleranz: IT 9 (erreichbar)  
 Beschichtung: MxP  
 Schneidanzahl: 3  
 Anzahl Führungsfasen: 3  
 Spitzenwinkel: 135°  
 Spiralwinkel: 30°

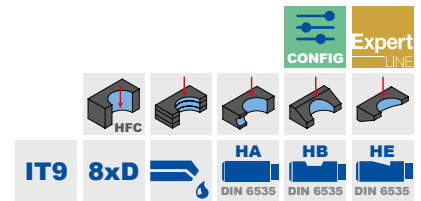
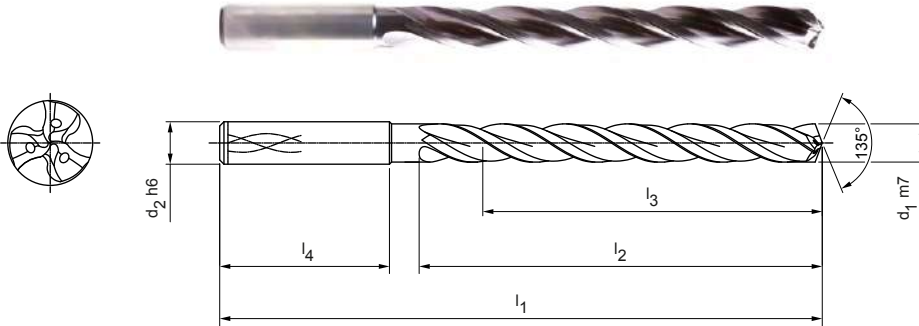

**Lagerhaltige Vorzugsbaureihe in Schaftform HA**

Baumaße						Schaftform HA	
d <sub>1</sub> m7	d <sub>2</sub> h6	l <sub>1</sub>	l <sub>2</sub>	l <sub>3</sub>	l <sub>4</sub>	Spezifikation	Bestell-Nr.
4,00	6	81	43	36	36	M9538P-0400AR	31005253
4,10	6	81	43	36	36	M9538P-0410AR	31005254
4,30	6	81	43	36	36	M9538P-0430AR	31005256
4,50	6	81	43	36	36	M9538P-0450AR	31005258
4,60	6	81	43	36	36	M9538P-0460AR	31005259
4,70	6	81	43	36	36	M9538P-0470AR	31005260
4,90	6	95	57	48	36	M9538P-0490AR	31005262
5,00	6	95	57	48	36	M9538P-0500AR	31005263
5,03	6	95	57	48	36	M9538P-0503AR	31249966
5,10	6	95	57	48	36	M9538P-0510AR	31005264
5,20	6	95	57	48	36	M9538P-0520AR	31005265
5,50	6	95	57	48	36	M9538P-0550AR	31005268
5,60	6	95	57	48	36	M9538P-0560AR	31005270
5,80	6	95	57	48	36	M9538P-0580AR	31005272
6,00	6	95	57	48	36	M9538P-0600AR	31005274
6,10	8	114	76	64	36	M9538P-0610AR	31005275
6,50	8	114	76	64	36	M9538P-0650AR	31005279
6,80	8	114	76	64	36	M9538P-0680AR	31005282
6,90	8	114	76	64	36	M9538P-0690AR	31005283
7,00	8	114	76	64	36	M9538P-0700AR	31005284
7,10	8	114	76	64	36	M9538P-0710AR	31005285
7,50	8	114	76	64	36	M9538P-0750AR	31005289
7,80	8	114	76	64	36	M9538P-0780AR	31005292
7,90	8	114	76	64	36	M9538P-0790AR	31005293
8,00	8	114	76	64	36	M9538P-0800AR	31005294
8,50	10	142	95	80	40	M9538P-0850AR	31005299
8,80	10	142	95	80	40	M9538P-0880AR	31005302
9,00	10	142	95	80	40	M9538P-0900AR	31005304
9,10	10	142	95	80	40	M9538P-0910AR	31005305
9,40	10	142	95	80	40	M9538P-0940AR	31005308
9,50	10	142	95	80	40	M9538P-0950AR	31005309
9,80	10	142	95	80	40	M9538P-0980AR	31005312
10,00	10	142	95	80	40	M9538P-1000AR	31005314
11,00	12	162	114	96	45	M9538P-1100AR	31005324
11,80	12	162	114	96	45	M9538P-1180AR	31005332

**Tritan-Drill-Uni-Plus | Vollhartmetall-Spiralbohrer M9538P (8xD), innere Kühlmittelzufuhr**

Baumaße						Schaftform HA	
d <sub>1</sub> m7	d <sub>2</sub> h6	l <sub>1</sub>	l <sub>2</sub>	l <sub>3</sub>	l <sub>4</sub>	Spezifikation	Bestell-Nr.
12,00	12	162	114	96	45	M9538P-1200AR	31005334
12,50	14	178	133	112	45	M9538P-1250AR	31005335
13,00	14	178	133	112	45	M9538P-1300AR	31005337
13,50	14	178	133	112	45	M9538P-1350AR	31005338
14,00	14	178	133	112	45	M9538P-1400AR	31005340
15,00	16	203	152	128	48	M9538P-1500AR	31005343
16,00	16	203	152	128	48	M9538P-1600AR	31005346
17,00	18	222	171	144	48	M9538P-1700AR	31005349

**Konfigurierbare Merkmale****Durchmesser:**

Durchmesser in Abstufungen  
von 0,01 mm frei wählbar

**Schaftform:**

Schaftform: HB | HE

**Spezifikation:**

M9538P-[Durchmesser][Schaftform]R

**Abmessungen konfigurierbare Baureihe**

d <sub>1</sub> min.	d <sub>1</sub> max.	d <sub>2</sub> h6	l <sub>1</sub>	l <sub>2</sub>	l <sub>3</sub>	l <sub>4</sub>
4,00	4,70	6	81	43	36	36
4,71	6,00	6	95	57	48	36
6,01	8,00	8	114	76	64	36
8,01	10,00	10	142	95	80	40
10,01	12,00	12	162	114	96	45
12,01	14,00	14	178	133	112	45
14,01	16,00	16	203	152	128	48
16,01	18,00	18	222	171	144	48
18,01	20,00	20	243	190	160	50

**Beispiel:**  
M9538P-0431ER

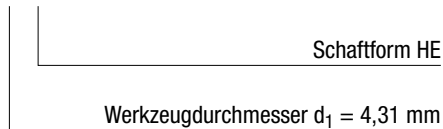

Maßangaben in mm.

Schnittwertempfehlung siehe Kapitelende.

Sonderausführungen und andere Beschichtungen auf Anfrage.

# Tritan-Drill-Uni-Plus

Vollhartmetall-Spiralbohrer

M9542P (12xD), innere Kühlmittelzufuhr, Nachfolgeprodukt des Tritan-Drill-Uni (M9542)

## Ausführung:

Bohrerdurchmesser: 4,00 – 20,00 mm  
 Bohrungstoleranz: IT 9 (erreichbar)  
 Beschichtung: MxP  
 Schneidanzahl: 3  
 Anzahl Führungsfasen: 3  
 Spitzenwinkel: 135°  
 Spiralwinkel: 30°

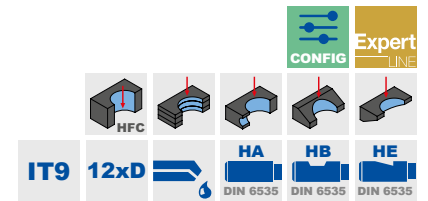
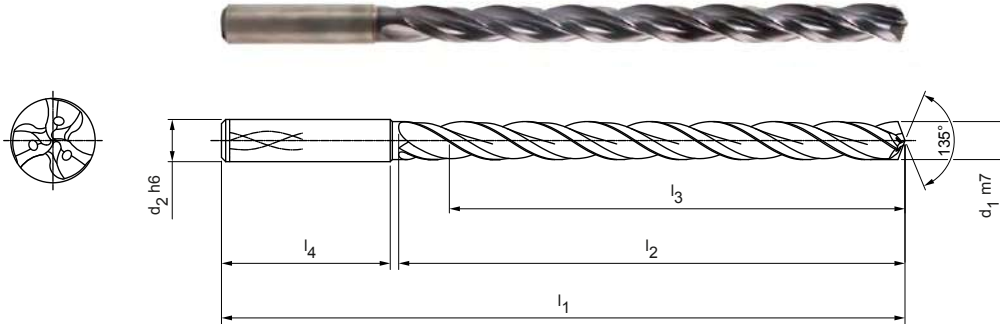

## Lagerhaltige Vorzugsbaureihe in Schaftform HA

Baumaße						Schaftform HA	
d <sub>1</sub> m7	d <sub>2</sub> h6	l <sub>1</sub>	l <sub>2</sub>	l <sub>3</sub>	l <sub>4</sub>	Spezifikation	Bestell-Nr.
4,00	6	102	64	58	36	M9542P-0400AR	31035066
4,10	6	102	64	58	36	M9542P-0410AR	31035067
4,20	6	102	64	58	36	M9542P-0420AR	31035068
4,30	6	102	64	58	36	M9542P-0430AR	31035069
4,50	6	102	64	58	36	M9542P-0450AR	31035121
4,60	6	102	64	58	36	M9542P-0460AR	31035122
4,70	6	102	64	58	36	M9542P-0470AR	31035123
4,80	6	116	78	70	36	M9542P-0480AR	31035124
5,00	6	116	78	70	36	M9542P-0500AR	31035126
5,10	6	116	78	70	36	M9542P-0510AR	31035127
5,20	6	116	78	70	36	M9542P-0520AR	31035128
5,40	6	116	78	70	36	M9542P-0540AR	31035130
5,50	6	116	78	70	36	M9542P-0550AR	31035131
5,80	6	116	78	70	36	M9542P-0580AR	31035134
6,00	6	116	78	70	36	M9542P-0600AR	31035136
6,10	8	146	108	94	36	M9542P-0610AR	31035137
6,20	8	146	108	94	36	M9542P-0620AR	31035138
6,50	8	146	108	94	36	M9542P-0650AR	31035142
6,60	8	146	108	94	36	M9542P-0660AR	31035143
6,80	8	146	108	94	36	M9542P-0680AR	31035145
7,00	8	146	108	94	36	M9542P-0700AR	31035147
7,50	8	146	108	94	36	M9542P-0750AR	31035152
7,80	8	146	108	94	36	M9542P-0780AR	31035155
8,00	8	146	108	94	36	M9542P-0800AR	31035157
8,50	10	162	120	110	40	M9542P-0850AR	31035162
9,00	10	162	120	110	40	M9542P-0900AR	31035167
9,50	10	162	120	110	40	M9542P-0950AR	31035172
9,80	10	162	120	110	40	M9542P-0980AR	31035175
9,90	10	162	120	110	40	M9542P-0990AR	31035176
10,00	10	162	120	110	40	M9542P-1000AR	31035177
10,20	12	204	156	142	45	M9542P-1020AR	31035179
10,50	12	204	156	142	45	M9542P-1050AR	31035182
11,00	12	204	156	142	45	M9542P-1100AR	31035187
11,30	12	204	156	142	45	M9542P-1130AR	31035190
11,80	12	204	156	142	45	M9542P-1180AR	31035195



## Tritan-Drill-Uni-Plus | Vollhartmetall-Spiralbohrer M9542P (12xD), innere Kühlmittelzufuhr

Baumaße						Schaftform HA	
d <sub>1</sub> m7	d <sub>2</sub> h6	l <sub>1</sub>	l <sub>2</sub>	l <sub>3</sub>	l <sub>4</sub>	Spezifikation	Bestell-Nr.
12,00	12	204	156	142	45	M9542P-1200AR	31035197
12,50	14	230	182	166	45	M9542P-1250AR	31035199
13,00	14	230	182	166	45	M9542P-1300AR	31035201
13,50	14	230	182	166	45	M9542P-1350AR	31035203
13,80	14	230	182	166	45	M9542P-1380AR	31035204
14,00	14	230	182	166	45	M9542P-1400AR	31035205
15,00	16	260	208	192	48	M9542P-1500AR	31035209
15,80	16	260	208	192	48	M9542P-1580AR	31035212
16,00	16	260	208	192	48	M9542P-1600AR	31035214

## Konfigurierbare Merkmale

**Durchmesser:**

Durchmesser in Abstufungen  
von 0,01 mm frei wählbar

**Schaftform:**

Schaftform: HB | HE

**Spezifikation:**

M9542P-[Durchmesser][Schaftform]R

## Abmessungen konfigurierbare Baureihe

d <sub>1</sub> min.	d <sub>1</sub> max.	d <sub>2</sub> h6	l <sub>1</sub>	l <sub>2</sub>	l <sub>3</sub>	l <sub>4</sub>
4,00	4,70	6	102	64	58	36
4,71	6,00	6	116	78	70	36
6,01	8,00	8	146	108	94	36
8,01	10,00	10	162	120	110	40
10,01	12,00	12	204	156	142	45
12,01	14,00	14	230	182	166	45
14,01	16,00	16	260	208	192	48
16,01	18,00	18	285	234	216	48
18,01	20,00	20	310	258	240	50

**Beispiel:**  
M9542P-0431ER

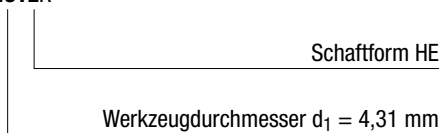

Maßangaben in mm.

Schnittwertempfehlung siehe Kapitelende.

Sonderausführungen und andere Beschichtungen auf Anfrage.

# MEGA-Speed-Drill-Uni

Vollhartmetall-Spiralbohrer  
M9103 (3xD), innere Kühlmittelzufuhr

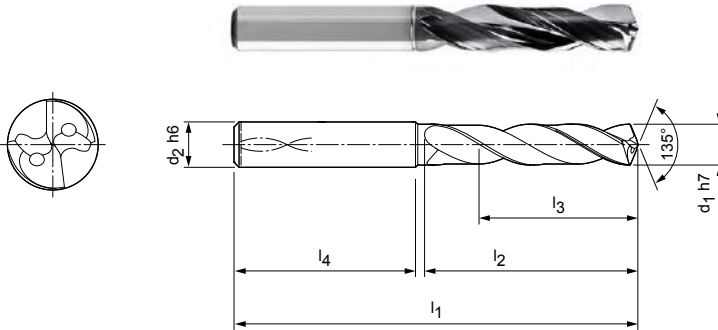

## Ausführung:

Bohrerdurchmesser: 3,00 - 20,00 mm  
Bohrungstoleranz:  $\geq$  IT 9  
Beschichtung: Mx2  
Schneidenanzahl: 2  
Anzahl Führungsfasen: 3  
Spitzenwinkel: 135°  
Spiralwinkel: 30°

## Anwendung:

Für Hochgeschwindigkeitsbearbeitung.



## Lagerhaltige Vorzugsbaureihe in Schaftform HA

Baumaße						Schaftform HA	
d <sub>1</sub> h7	d <sub>2</sub> h6	l <sub>1</sub>	l <sub>2</sub>	l <sub>3</sub>	l <sub>4</sub>	Spezifikation	Bestell-Nr.
3,00	6	62	20	14	36	M9103-0300AK	30265089
3,10	6	62	20	14	36	M9103-0310AK	30265090
3,20	6	62	20	14	36	M9103-0320AK	30265091
3,30	6	62	20	14	36	M9103-0330AK	30265092
3,40	6	62	20	14	36	M9103-0340AK	30265093
3,50	6	62	20	14	36	M9103-0350AK	30265094
3,70	6	62	20	14	36	M9103-0370AK	30265096
4,00	6	66	24	17	36	M9103-0400AK	30265099
4,20	6	66	24	17	36	M9103-0420AK	30265101
4,30	6	66	24	17	36	M9103-0430AK	30265102
4,50	6	66	24	17	36	M9103-0450AK	30265104
5,00	6	66	28	20	36	M9103-0500AK	30265110
5,10	6	66	28	20	36	M9103-0510AK	30265111
5,20	6	66	28	20	36	M9103-0520AK	30265112
5,50	6	66	28	20	36	M9103-0550AK	30265115
5,55	6	66	28	20	36	M9103-0555AK	30265116
5,60	6	66	28	20	36	M9103-0560AK	30265117
5,80	6	66	28	20	36	M9103-0580AK	30265119
6,00	6	66	28	20	36	M9103-0600AK	30265121
6,30	8	79	34	24	36	M9103-0630AK	30265124
6,50	8	79	34	24	36	M9103-0650AK	30265126
6,80	8	79	34	24	36	M9103-0680AK	30265129
6,90	8	79	34	24	36	M9103-0690AK	30265130
7,00	8	79	34	24	36	M9103-0700AK	30265131
7,40	8	79	41	29	36	M9103-0740AK	30265135
7,50	8	79	41	29	36	M9103-0750AK	30265136
7,80	8	79	41	29	36	M9103-0780AK	30265139
8,00	8	79	41	29	36	M9103-0800AK	30265141
8,50	10	89	47	35	40	M9103-0850AK	30265146
8,60	10	89	47	35	40	M9103-0860AK	30265147
8,80	10	89	47	35	40	M9103-0880AK	30265149
9,00	10	89	47	35	40	M9103-0900AK	30265151
9,50	10	89	47	35	40	M9103-0950AK	30265156
9,80	10	89	47	35	40	M9103-0980AK	30265159
9,90	10	89	47	35	40	M9103-0990AK	30265160

**MEGA-Speed-Drill-Uni | Vollhartmetall-Spiralbohrer M9103 (3xD), innere Kühlmittelzufuhr**

Baumaße						Schaffform HA	
d <sub>1</sub> h7	d <sub>2</sub> h6	l <sub>1</sub>	l <sub>2</sub>	l <sub>3</sub>	l <sub>4</sub>	Spezifikation	Bestell-Nr.
10,00	10	89	47	35	40	M9103-1000AK	30265161
10,20	12	102	55	40	45	M9103-1020AK	30265163
10,30	12	102	55	40	45	M9103-1030AK	30265164
10,50	12	102	55	40	45	M9103-1050AK	30265166
10,60	12	102	55	40	45	M9103-1060AK	30265167
11,00	12	102	55	40	45	M9103-1100AK	30265171
11,50	12	102	55	40	45	M9103-1150AK	30265176
11,60	12	102	55	40	45	M9103-1160AK	30265177
11,80	12	102	55	40	45	M9103-1180AK	30265179
12,00	12	102	55	40	45	M9103-1200AK	30265181
12,50	14	107	60	43	45	M9103-1250AK	30265182
13,00	14	107	60	43	45	M9103-1300AK	30265184
13,50	14	107	60	43	45	M9103-1350AK	30265185
14,00	14	107	60	43	45	M9103-1400AK	30265187
14,50	16	115	65	45	48	M9103-1450AK	30265188
15,00	16	115	65	45	48	M9103-1500AK	30265190
16,00	16	115	65	45	48	M9103-1600AK	30265193
17,00	18	123	73	51	48	M9103-1700AK	30265196
17,50	18	123	73	51	48	M9103-1750AK	30265197
17,80	18	123	73	51	48	M9103-1780AK	30265198
18,00	18	123	73	51	48	M9103-1800AK	30265199
18,50	20	131	79	55	50	M9103-1850AK	30265200
19,50	20	131	79	55	50	M9103-1950AK	30265203
20,00	20	131	79	55	50	M9103-2000AK	30265205

**Konfigurierbare Merkmale**



**Durchmesser:**  
Durchmesser in Abstufungen  
von 0,01 mm frei wählbar



**Schaffform:**  
Schaffform: HB | HE

**Spezifikation:**  
M9103-[Durchmesser][Schaffform]K

**Abmessungen konfigurierbare Baureihe**

d <sub>1</sub> min.	d <sub>1</sub> max.	d <sub>2</sub> h6	l <sub>1</sub>	l <sub>2</sub>	l <sub>3</sub>	l <sub>4</sub>
3,00	3,70	6	62	20	14	36
3,71	4,70	6	66	24	17	36
4,71	6,00	6	66	28	20	36
6,01	8,00	8	79	34	24	36
8,01	10,00	10	89	47	35	40
10,01	12,00	12	102	55	40	45
12,01	14,00	14	107	60	43	45
14,01	16,00	16	115	65	45	48
16,01	18,00	18	123	73	51	48
18,01	20,00	20	131	79	55	50

**Beispiel:**  
M9103-0431EK

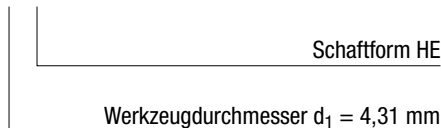

Maßangaben in mm.  
Schnittwertempfehlung siehe Kapitelende.  
Sonderausführungen und andere Beschichtungen auf Anfrage.

# MEGA-Speed-Drill-Uni

Vollhartmetall-Spiralbohrer  
M9105 (5xD), innere Kühlmittelzufuhr

**Ausführung:**  
Bohrerdurchmesser: 3,00 - 20,00 mm  
Bohrungstoleranz:  $\geq$  IT 9  
Beschichtung: Mx2  
Schneidenanzahl: 2  
Anzahl Führungsfasen: 3  
Spitzenwinkel: 135°  
Spiralwinkel: 30°

**Anwendung:**  
Für Hochgeschwindigkeitsbearbeitung.

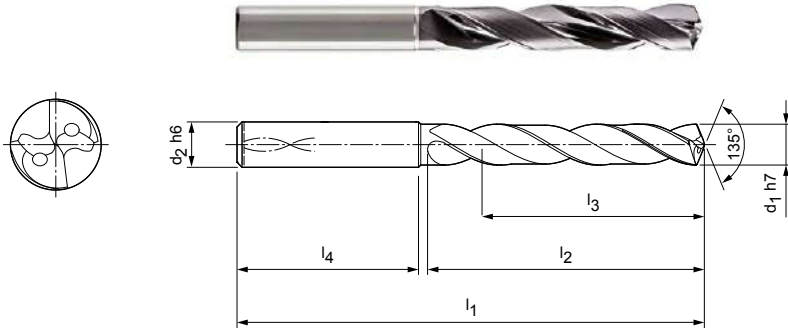

**Lagerhaltige Vorzugsbaureihe in Schaftform HA**

Baumaße						Schaftform HA	
d <sub>1</sub> h7	d <sub>2</sub> h6	l <sub>1</sub>	l <sub>2</sub>	l <sub>3</sub>	l <sub>4</sub>	Spezifikation	Bestell-Nr.
3,00	6	66	28	23	36	M9105-0300AK	30260858
3,10	6	66	28	23	36	M9105-0310AK	30260859
3,20	6	66	28	23	36	M9105-0320AK	30260860
3,30	6	66	28	23	36	M9105-0330AK	30260861
3,40	6	66	28	23	36	M9105-0340AK	30260862
3,50	6	66	28	23	36	M9105-0350AK	30260863
3,70	6	66	28	23	36	M9105-0370AK	30260865
4,00	6	74	36	29	36	M9105-0400AK	30260868
4,20	6	74	36	29	36	M9105-0420AK	30260870
4,30	6	74	36	29	36	M9105-0430AK	30260871
4,50	6	74	36	29	36	M9105-0450AK	30260873
5,00	6	82	44	35	36	M9105-0500AK	30260879
5,10	6	82	44	35	36	M9105-0510AK	30260880
5,20	6	82	44	35	36	M9105-0520AK	30260881
5,50	6	82	44	35	36	M9105-0550AK	30260884
5,60	6	82	44	35	36	M9105-0560AK	30260886
5,80	6	82	44	35	36	M9105-0580AK	30260888
6,00	6	82	44	35	36	M9105-0600AK	30260890
6,50	8	91	53	43	36	M9105-0650AK	30260895
6,60	8	91	53	43	36	M9105-0660AK	30260896
6,80	8	91	53	43	36	M9105-0680AK	30260898
6,90	8	91	53	43	36	M9105-0690AK	30260899
7,00	8	91	53	43	36	M9105-0700AK	30260900
7,40	8	91	53	43	36	M9105-0740AK	30260903
7,50	8	91	53	43	36	M9105-0750AK	30260904
7,80	8	91	53	43	36	M9105-0780AK	30260906
8,00	8	91	53	43	36	M9105-0800AK	30260908
8,50	10	103	61	49	40	M9105-0850AK	30260913
8,60	10	103	61	49	40	M9105-0860AK	30260914
8,80	10	103	61	49	40	M9105-0880AK	30260916
9,00	10	103	61	49	40	M9105-0900AK	30260917
9,50	10	103	61	49	40	M9105-0950AK	30260920
9,70	10	103	61	49	40	M9105-0970AK	30260922
9,80	10	103	61	49	40	M9105-0980AK	30260923
10,00	10	103	61	49	40	M9105-1000AK	30260925

**MEGA-Speed-Drill-Uni | Vollhartmetall-Spiralbohrer M9105 (5xD), innere Kühlmittelzufuhr**

Baumaße						Schaffform HA	
d <sub>1</sub> h7	d <sub>2</sub> h6	l <sub>1</sub>	l <sub>2</sub>	l <sub>3</sub>	l <sub>4</sub>	Spezifikation	Bestell-Nr.
10,20	12	118	71	56	45	M9105-1020AK	30260927
10,30	12	118	71	56	45	M9105-1030AK	30260928
10,50	12	118	71	56	45	M9105-1050AK	30260930
11,00	12	118	71	56	45	M9105-1100AK	30260934
11,50	12	118	71	56	45	M9105-1150AK	30260937
11,80	12	118	71	56	45	M9105-1180AK	30260940
12,00	12	118	71	56	45	M9105-1200AK	30260941
12,50	14	124	77	60	45	M9105-1250AK	30260942
13,00	14	124	77	60	45	M9105-1300AK	30260944
13,50	14	124	77	60	45	M9105-1350AK	30260945
13,80	14	124	77	60	45	M9105-1380AK	30260946
14,00	14	124	77	60	45	M9105-1400AK	30260947
14,50	16	133	83	63	48	M9105-1450AK	30260948
15,00	16	133	83	63	48	M9105-1500AK	30260950
15,50	16	133	83	63	48	M9105-1550AK	30260951
15,80	16	133	83	63	48	M9105-1580AK	30260952
16,00	16	133	83	63	48	M9105-1600AK	30260953
16,80	18	143	93	71	48	M9105-1680AK	30261196
17,00	18	143	93	71	48	M9105-1700AK	30260955
17,50	18	143	93	71	48	M9105-1750AK	30260956
17,80	18	143	93	71	48	M9105-1780AK	30261197
18,00	18	143	93	71	48	M9105-1800AK	30260957
18,50	20	153	101	77	50	M9105-1850AK	30261198
18,80	20	153	101	77	50	M9105-1880AK	30261199
19,00	20	153	101	77	50	M9105-1900AK	30260958
20,00	20	153	101	77	50	M9105-2000AK	30260959

**Konfigurierbare Merkmale**

**Durchmesser:**  
Durchmesser in Abstufungen  
von 0,01 mm frei wählbar

**Schaffform:**  
Schaffform: HB | HE

**Spezifikation:**  
M9105-[Durchmesser][Schaffform]K

**Abmessungen konfigurierbare Baureihe**

d <sub>1</sub> min.	d <sub>1</sub> max.	d <sub>2</sub> h6	l <sub>1</sub>	l <sub>2</sub>	l <sub>3</sub>	l <sub>4</sub>
3,00	3,70	6	66	28	23	36
3,71	4,70	6	74	36	29	36
4,71	6,00	6	82	44	35	36
6,01	8,00	8	91	53	43	36
8,01	10,00	10	103	61	49	40
10,01	12,00	12	118	71	56	45
12,01	14,00	14	124	77	60	45
14,01	16,00	16	133	83	63	48
16,01	18,00	18	143	93	71	48
18,01	20,00	20	153	101	77	50

**Beispiel:**  
M9105-0431EK

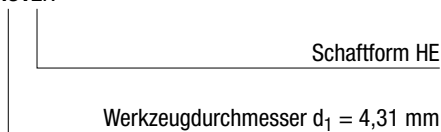

Maßangaben in mm.  
Schnittwertempfehlung siehe Kapitelende.  
Sonderausführungen und andere Beschichtungen auf Anfrage.

# MEGA-Speed-Drill-Uni

Vollhartmetall-Spiralbohrer  
M9108 (8xD), innere Kühlmittelzufuhr

**Ausführung:**

Bohrerdurchmesser: 3,00 - 20,00 mm  
Bohrungstoleranz:  $\geq$  IT 9  
Beschichtung: Mx2  
Schneidenanzahl: 2  
Anzahl Führungsfasen: 3  
Spitzenwinkel: 135°  
Spiralwinkel: 30°

**Anwendung:**

Für Hochgeschwindigkeitsbearbeitung.

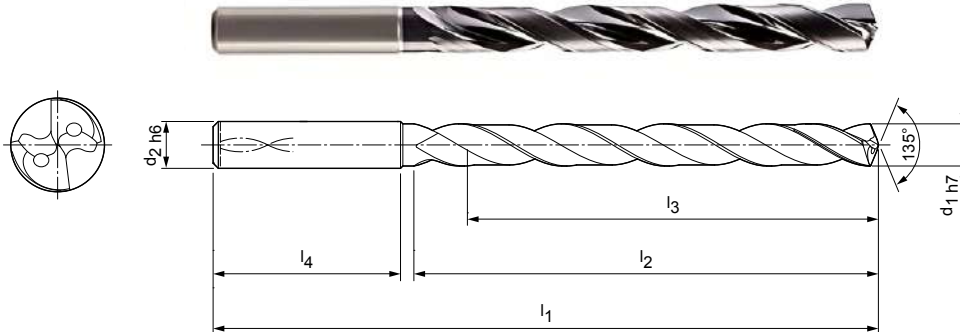

**Lagerhaltige Vorzugsbaureihe in Schaftform HA**

Baumaße						Schaftform HA	
d <sub>1</sub> h7	d <sub>2</sub> h6	l <sub>1</sub>	l <sub>2</sub>	l <sub>3</sub>	l <sub>4</sub>	Spezifikation	Bestell-Nr.
3,00	6	72	34	29	36	M9108-0300AK	30265206
3,20	6	72	34	29	36	M9108-0320AK	30265208
3,30	6	72	34	29	36	M9108-0330AK	30265209
3,40	6	72	34	29	36	M9108-0340AK	30265210
3,50	6	72	34	29	36	M9108-0350AK	30265211
3,70	6	72	34	29	36	M9108-0370AK	30265213
4,00	6	81	43	36	36	M9108-0400AK	30265216
4,10	6	81	43	36	36	M9108-0410AK	30265217
4,20	6	81	43	36	36	M9108-0420AK	30265218
4,30	6	81	43	36	36	M9108-0430AK	30265219
4,50	6	81	43	36	36	M9108-0450AK	30265221
4,80	6	95	57	48	36	M9108-0480AK	30265225
5,00	6	95	57	48	36	M9108-0500AK	30265227
5,10	6	95	57	48	36	M9108-0510AK	30265228
5,20	6	95	57	48	36	M9108-0520AK	30265229
5,40	6	95	57	48	36	M9108-0540AK	30265231
5,50	6	95	57	48	36	M9108-0550AK	30265232
5,80	6	95	57	48	36	M9108-0580AK	30265236
6,00	6	95	57	48	36	M9108-0600AK	30265238
6,10	8	114	76	64	36	M9108-0610AK	30265239
6,40	8	114	76	64	36	M9108-0640AK	30265242
6,50	8	114	76	64	36	M9108-0650AK	30265243
6,80	8	114	76	64	36	M9108-0680AK	30265246
7,00	8	114	76	64	36	M9108-0700AK	30265248
7,50	8	114	76	64	36	M9108-0750AK	30265253
7,80	8	114	76	64	36	M9108-0780AK	30265256
8,00	8	114	76	64	36	M9108-0800AK	30265258
8,50	10	142	95	80	40	M9108-0850AK	30265263
9,00	10	142	95	80	40	M9108-0900AK	30265268
9,30	10	142	95	80	40	M9108-0930AK	30265271
9,50	10	142	95	80	40	M9108-0950AK	30265273
9,60	10	142	95	80	40	M9108-0960AK	30265274
9,80	10	142	95	80	40	M9108-0980AK	30265276
10,00	10	142	95	80	40	M9108-1000AK	30265278
10,20	12	162	114	96	45	M9108-1020AK	30265280

## MEGA-Speed-Drill-Uni | Vollhartmetall-Spiralbohrer M9108 (8xD), innere Kühlmittelzufuhr

Baumaße						Schaffform HA	
d <sub>1</sub> h7	d <sub>2</sub> h6	l <sub>1</sub>	l <sub>2</sub>	l <sub>3</sub>	l <sub>4</sub>	Spezifikation	Bestell-Nr.
10,50	12	162	114	96	45	M9108-1050AK	30265283
11,00	12	162	114	96	45	M9108-1100AK	30265288
11,40	12	162	114	96	45	M9108-1140AK	30265292
11,80	12	162	114	96	45	M9108-1180AK	30265296
12,00	12	162	114	96	45	M9108-1200AK	30265298
12,50	14	178	133	112	45	M9108-1250AK	30265299
13,00	14	178	133	112	45	M9108-1300AK	30265301
13,50	14	178	133	112	45	M9108-1350AK	30265302
14,00	14	178	133	112	45	M9108-1400AK	30265304
15,00	16	203	152	128	48	M9108-1500AK	30265307
16,00	16	203	152	128	48	M9108-1600AK	30265310
17,50	18	222	171	144	48	M9108-1750AK	30265314

## Konfigurierbare Merkmale



**Durchmesser:**  
Durchmesser in Abstufungen  
von 0,01 mm frei wählbar



**Schaffform:**  
Schaffform: HB | HE

**Spezifikation:**

M9108-[Durchmesser][Schaffform]K

## Abmessungen konfigurierbare Baureihe

d <sub>1</sub> min.	d <sub>1</sub> max.	d <sub>2</sub> h6	l <sub>1</sub>	l <sub>2</sub>	l <sub>3</sub>	l <sub>4</sub>
3,00	3,70	6	72	34	29	36
3,71	4,70	6	81	43	36	36
4,80	6,00	6	95	57	48	36
6,01	8,00	8	114	76	64	36
8,01	10,00	10	142	95	80	40
10,01	12,00	12	162	114	96	45
12,01	14,00	14	178	133	112	45
14,01	16,00	16	203	152	128	48
16,01	18,00	18	222	171	144	48
18,01	20,00	20	243	190	160	50

**Beispiel:**  
M9108-0431EK

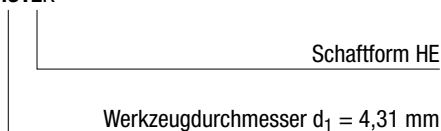

Maßangaben in mm.

Schnittwertempfehlung siehe Kapitelende.

Sonderausführungen und andere Beschichtungen auf Anfrage.

# ECU-Drill-Uni

Vollhartmetall-Spiralbohrer  
M6804 (4xD), innere Kühlmittelzufuhr

## Ausführung:

Bohrerdurchmesser: 3,00 - 20,00 mm  
Bohrungstoleranz:  $\geq$  IT 9  
Beschichtung: Mx5  
Schneidenanzahl: 2  
Spitzenwinkel: 140°  
Spiralwinkel: 30°

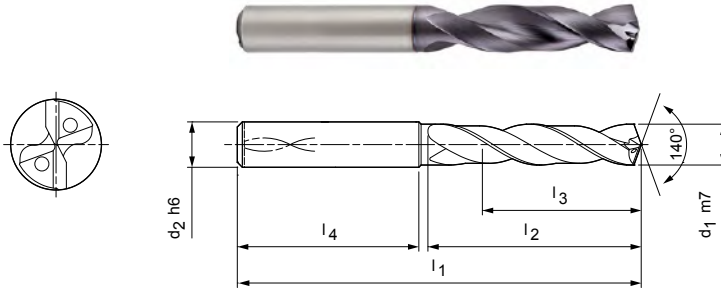

## Lagerhaltige Vorzugsbaureihe in Schaftform HA

Baumaße						Schaftform HA	
d <sub>1</sub> m7	d <sub>2</sub> h6	l <sub>1</sub>	l <sub>2</sub>	l <sub>3</sub>	l <sub>4</sub>	Spezifikation	Bestell-Nr.
3,00	6	62	22	16	36	M6804-0300AV	30246405
3,10	6	62	22	16	36	M6804-0310AV	30246406
3,20	6	62	22	16	36	M6804-0320AV	30246407
3,30	6	62	22	16	36	M6804-0330AV	30246408
3,40	6	62	22	16	36	M6804-0340AV	30246409
3,50	6	62	22	16	36	M6804-0350AV	30246410
3,60	6	62	22	16	36	M6804-0360AV	30246411
3,70*	6	62	22	16	36	M6804-0370AV	30246412
3,80	6	66	26	22	36	M6804-0380AV	30246413
3,90	6	66	26	22	36	M6804-0390AV	30246414
4,00	6	66	26	22	36	M6804-0400AV	30246415
4,10	6	66	26	22	36	M6804-0410AV	30246416
4,20	6	66	26	22	36	M6804-0420AV	30246417
4,30	6	66	26	22	36	M6804-0430AV	30246418
4,40	6	66	26	22	36	M6804-0440AV	30246419
4,50	6	66	26	22	36	M6804-0450AV	30246420
4,60	6	66	26	22	36	M6804-0460AV	30246421
4,65*	6	66	26	22	36	M6804-0465AV	30296630
4,70	6	66	26	22	36	M6804-0470AV	30246422
4,80	6	66	30	24	36	M6804-0480AV	30246423
4,90	6	66	30	24	36	M6804-0490AV	30246424
5,00	6	66	30	24	36	M6804-0500AV	30246425
5,10	6	66	30	24	36	M6804-0510AV	30246426
5,20	6	66	30	24	36	M6804-0520AV	30246427
5,30	6	66	30	24	36	M6804-0530AV	30246428
5,40	6	66	30	24	36	M6804-0540AV	30246429
5,50	6	66	30	24	36	M6804-0550AV	30246430
5,55*	6	66	30	24	36	M6804-0555AV	30296631
5,60	6	66	30	24	36	M6804-0560AV	30246431
5,70	6	66	30	24	36	M6804-0570AV	30246432
5,80	6	66	30	24	36	M6804-0580AV	30246433
5,90	6	66	30	24	36	M6804-0590AV	30246434
6,00	6	66	30	24	36	M6804-0600AV	30246435
6,10	8	79	38	30	36	M6804-0610AV	30246436



## ECU-Drill-Uni | Vollhartmetall-Spiralbohrer M6804 (4xD), innere Kühlmittelzufuhr

Baumaße						Schaftform HA	
d <sub>1</sub> m7	d <sub>2</sub> h6	l <sub>1</sub>	l <sub>2</sub>	l <sub>3</sub>	l <sub>4</sub>	Spezifikation	Bestell-Nr.
6,20	8	79	38	30	36	M6804-0620AV	30246437
6,30	8	79	38	30	36	M6804-0630AV	30246438
6,40	8	79	38	30	36	M6804-0640AV	30246439
6,50	8	79	38	30	36	M6804-0650AV	30246440
6,60	8	79	38	30	36	M6804-0660AV	30246441
6,70	8	79	38	30	36	M6804-0670AV	30246442
6,80	8	79	38	30	36	M6804-0680AV	30246443
6,90	8	79	38	30	36	M6804-0690AV	30246444
7,00	8	79	38	30	36	M6804-0700AV	30246445
7,10	8	79	42	34	36	M6804-0710AV	30246446
7,20	8	79	42	34	36	M6804-0720AV	30246447
7,30	8	79	42	34	36	M6804-0730AV	30246448
7,40	8	79	42	34	36	M6804-0740AV	30246449
7,45*	8	79	42	34	36	M6804-0745AV	30530768
7,50	8	79	42	34	36	M6804-0750AV	30246450
7,60	8	79	42	34	36	M6804-0760AV	30246451
7,70	8	79	42	34	36	M6804-0770AV	30246452
7,80	8	79	42	34	36	M6804-0780AV	30246453
7,90	8	79	42	34	36	M6804-0790AV	30246454
8,00	8	79	42	34	36	M6804-0800AV	30246455
8,10	10	89	49	38	40	M6804-0810AV	30246456
8,20	10	89	49	38	40	M6804-0820AV	30246457
8,30	10	89	49	38	40	M6804-0830AV	30246458
8,40	10	89	49	38	40	M6804-0840AV	30246459
8,50	10	89	49	38	40	M6804-0850AV	30246460
8,60	10	89	49	38	40	M6804-0860AV	30246461
8,70	10	89	49	38	40	M6804-0870AV	30246462
8,80	10	89	49	38	40	M6804-0880AV	30246463
8,90	10	89	49	38	40	M6804-0890AV	30246464
9,00	10	89	49	38	40	M6804-0900AV	30246465
9,10	10	89	49	38	40	M6804-0910AV	30246466
9,20	10	89	49	38	40	M6804-0920AV	30246467
9,30*	10	89	49	40	40	M6804-0930AV	30246468
9,40	10	89	49	40	40	M6804-0940AV	30246469
9,50	10	89	49	40	40	M6804-0950AV	30246470
9,60	10	89	49	40	40	M6804-0960AV	30246471
9,70	10	89	49	40	40	M6804-0970AV	30246472
9,80	10	89	49	40	40	M6804-0980AV	30246473
9,90	10	89	49	40	40	M6804-0990AV	30246474
10,00	10	89	49	40	40	M6804-1000AV	30246475
10,10	12	102	56	45	45	M6804-1010AV	30294596
10,20	12	102	56	45	45	M6804-1020AV	30246476
10,30	12	102	56	45	45	M6804-1030AV	30246477
10,40	12	102	56	45	45	M6804-1040AV	30294597
10,50	12	102	56	45	45	M6804-1050AV	30246478
10,60	12	102	56	45	45	M6804-1060AV	30294598
10,70	12	102	56	45	45	M6804-1070AV	30294599
10,80	12	102	56	45	45	M6804-1080AV	30246479
10,90	12	102	56	45	45	M6804-1090AV	30294600
11,00	12	102	56	45	45	M6804-1100AV	30246480
11,10	12	102	56	45	45	M6804-1110AV	30294601
11,20*	12	102	56	45	45	M6804-1120AV	30246481
11,50	12	102	56	45	45	M6804-1150AV	30246482
11,70	12	102	56	45	45	M6804-1170AV	30294605
11,80	12	102	56	45	45	M6804-1180AV	30246483

Fortsetzung auf nächster Seite.

## ECU-Drill-Uni | Vollhartmetall-Spiralbohrer M6804 (4xD), innere Kühlmittelzufuhr

Baumaße						Schaftform HA	
d <sub>1</sub> m7	d <sub>2</sub> h6	l <sub>1</sub>	l <sub>2</sub>	l <sub>3</sub>	l <sub>4</sub>	Spezifikation	Bestell-Nr.
11,90	12	102	56	45	45	M6804-1190AV	30294606
12,00	12	102	56	45	45	M6804-1200AV	30246484
12,20	14	107	61	50	45	M6804-1220AV	30246485
12,50	14	107	61	50	45	M6804-1250AV	30246486
12,70	14	107	61	50	45	M6804-1270AV	30303991
12,80	14	107	61	50	45	M6804-1280AV	30246487
13,00	14	107	61	50	45	M6804-1300AV	30246488
13,50	14	107	61	50	45	M6804-1350AV	30246489
13,80	14	107	61	50	45	M6804-1380AV	30246490
14,00	14	107	61	50	45	M6804-1400AV	30246491
14,20	16	115	65	51	48	M6804-1420AV	30246492
14,50	16	115	65	51	48	M6804-1450AV	30246493
14,80	16	115	65	51	48	M6804-1480AV	30246495
15,00	16	115	65	51	48	M6804-1500AV	30246496
15,10	16	115	65	51	48	M6804-1510AV	30246497
15,20	16	115	65	51	48	M6804-1520AV	30246498
15,50	16	115	65	51	48	M6804-1550AV	30246499
15,70	16	115	65	51	48	M6804-1570AV	30328796
15,80	16	115	65	51	48	M6804-1580AV	30246500
16,00	16	115	65	51	48	M6804-1600AV	30246501
16,50	18	123	73	53	48	M6804-1650AV	30246502
16,80	18	123	73	53	48	M6804-1680AV	30513804
17,00	18	123	73	53	48	M6804-1700AV	30246503
17,30	18	123	73	53	48	M6804-1730AV	30246504
17,50	18	123	73	53	48	M6804-1750AV	30246505
17,70	18	123	73	53	48	M6804-1770AV	30246506
18,00	18	123	73	53	48	M6804-1800AV	30246507
18,50	20	131	79	55	50	M6804-1850AV	30246508
19,00	20	131	79	55	50	M6804-1900AV	30246509
19,50	20	131	79	55	50	M6804-1950AV	30246511
20,00	20	131	79	55	50	M6804-2000AV	30246512

## Konfigurierbare Merkmale



**Schaftform:**  
Schaftform: HB | HE



**Spezifikation:**  
M6804-1500[Schaftform]V

Beispiel:  
M6804-1500EV

Schaftform HE

Maßangaben in mm.

\* Speziell zur Vorfertigung der Kernlöcher für Gewindeformer geeignet.

Schnittwertempfehlung siehe Kapitelende.

Sonderausführungen und andere Beschichtungen auf Anfrage.

# ECU-Drill-Uni

Vollhartmetall-Spiralbohrer  
M6704 (4xD), äußere Kühlmittelzufuhr

**Ausführung:**  
Bohrerdurchmesser: 3,00 - 20,00 mm  
Bohrungstoleranz:  $\geq$  IT 9  
Beschichtung: Mx5  
Schneidenanzahl: 2  
Spitzenwinkel: 140°  
Spiralwinkel: 30°

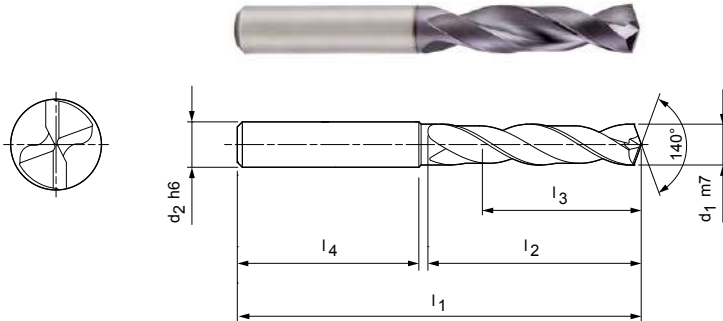

## Lagerhaltige Vorzugsbaureihe in Schaftform HA

Baumaße						Schaftform HA	
d <sub>1</sub> m7	d <sub>2</sub> h6	l <sub>1</sub>	l <sub>2</sub>	l <sub>3</sub>	l <sub>4</sub>	Spezifikation	Bestell-Nr.
3,00	6	62	22	16	36	M6704-0300AV	30246298
3,10	6	62	22	16	36	M6704-0310AV	30246299
3,20	6	62	22	16	36	M6704-0320AV	30246300
3,30	6	62	22	16	36	M6704-0330AV	30246301
3,40	6	62	22	16	36	M6704-0340AV	30246302
3,50	6	62	22	16	36	M6704-0350AV	30246303
3,60	6	62	22	16	36	M6704-0360AV	30246304
3,70*	6	62	22	16	36	M6704-0370AV	30246305
3,80	6	66	26	22	36	M6704-0380AV	30246306
3,90	6	66	26	22	36	M6704-0390AV	30246307
4,00	6	66	26	22	36	M6704-0400AV	30246308
4,10	6	66	26	22	36	M6704-0410AV	30246309
4,20	6	66	26	22	36	M6704-0420AV	30246310
4,30	6	66	26	22	36	M6704-0430AV	30246311
4,40	6	66	26	22	36	M6704-0440AV	30246312
4,50	6	66	26	22	36	M6704-0450AV	30246313
4,60	6	66	26	22	36	M6704-0460AV	30246314
4,65*	6	66	26	22	36	M6704-0465AV	30296622
4,70	6	66	26	22	36	M6704-0470AV	30246315
4,80	6	66	30	24	36	M6704-0480AV	30246316
4,90	6	66	30	24	36	M6704-0490AV	30246317
5,00	6	66	30	24	36	M6704-0500AV	30246318
5,10	6	66	30	24	36	M6704-0510AV	30246319
5,20	6	66	30	24	36	M6704-0520AV	30246320
5,30	6	66	30	24	36	M6704-0530AV	30246321
5,40	6	66	30	24	36	M6704-0540AV	30246322
5,50	6	66	30	24	36	M6704-0550AV	30246323
5,55*	6	66	30	24	36	M6704-0555AV	30296623
5,60	6	66	30	24	36	M6704-0560AV	30246324
5,70	6	66	30	24	36	M6704-0570AV	30246325
5,80	6	66	30	24	36	M6704-0580AV	30246326
5,90	6	66	30	24	36	M6704-0590AV	30246327
6,00	6	66	30	24	36	M6704-0600AV	30246328
6,10	8	79	38	30	36	M6704-0610AV	30246329

## ECU-Drill-Uni | Vollhartmetall-Spiralbohrer M6704 (4xD), äußere Kühlmittelzufuhr

Baumaße						Schaftform HA	
d <sub>1</sub> m7	d <sub>2</sub> h6	l <sub>1</sub>	l <sub>2</sub>	l <sub>3</sub>	l <sub>4</sub>	Spezifikation	Bestell-Nr.
6,20	8	79	38	30	36	M6704-0620AV	30246330
6,30	8	79	38	30	36	M6704-0630AV	30246331
6,40	8	79	38	30	36	M6704-0640AV	30246332
6,50	8	79	38	30	36	M6704-0650AV	30246333
6,60	8	79	38	30	36	M6704-0660AV	30246334
6,70	8	79	38	30	36	M6704-0670AV	30246335
6,80	8	79	38	30	36	M6704-0680AV	30246336
6,90	8	79	38	30	36	M6704-0690AV	30246337
7,00	8	79	38	30	36	M6704-0700AV	30246338
7,10	8	79	42	34	36	M6704-0710AV	30246339
7,20	8	79	42	34	36	M6704-0720AV	30246340
7,30	8	79	42	34	36	M6704-0730AV	30246341
7,40	8	79	42	34	36	M6704-0740AV	30246342
7,50	8	79	42	34	36	M6704-0750AV	30246343
7,60	8	79	42	34	36	M6704-0760AV	30246344
7,70	8	79	42	34	36	M6704-0770AV	30246345
7,80	8	79	42	34	36	M6704-0780AV	30246346
7,90	8	79	42	34	36	M6704-0790AV	30246347
8,00	8	79	42	34	36	M6704-0800AV	30246348
8,10	10	89	49	38	40	M6704-0810AV	30246349
8,20	10	89	49	38	40	M6704-0820AV	30246350
8,30	10	89	49	38	40	M6704-0830AV	30246351
8,40	10	89	49	38	40	M6704-0840AV	30246352
8,50	10	89	49	38	40	M6704-0850AV	30246353
8,60	10	89	49	38	40	M6704-0860AV	30246354
8,70	10	89	49	38	40	M6704-0870AV	30246355
8,80	10	89	49	38	40	M6704-0880AV	30246356
8,90	10	89	49	38	40	M6704-0890AV	30246357
9,00	10	89	49	38	40	M6704-0900AV	30246358
9,10	10	89	49	38	40	M6704-0910AV	30246359
9,20	10	89	49	38	40	M6704-0920AV	30246360
9,30*	10	89	49	40	40	M6704-0930AV	30246361
9,40	10	89	49	40	40	M6704-0940AV	30246362
9,50	10	89	49	40	40	M6704-0950AV	30246363
9,60	10	89	49	40	40	M6704-0960AV	30246364
9,70	10	89	49	40	40	M6704-0970AV	30246365
9,80	10	89	49	40	40	M6704-0980AV	30246366
9,90	10	89	49	40	40	M6704-0990AV	30246367
10,00	10	89	49	40	40	M6704-1000AV	30246368
10,10	12	102	56	45	45	M6704-1010AV	30294574
10,20	12	102	56	45	45	M6704-1020AV	30246369
10,30	12	102	56	45	45	M6704-1030AV	30246370
10,40	12	102	56	45	45	M6704-1040AV	30294575
10,50	12	102	56	45	45	M6704-1050AV	30246371
10,60	12	102	56	45	45	M6704-1060AV	30294576
10,80	12	102	56	45	45	M6704-1080AV	30246372
10,90	12	102	56	45	45	M6704-1090AV	30294578
11,00	12	102	56	45	45	M6704-1100AV	30246373
11,10	12	102	56	45	45	M6704-1110AV	30294579
11,20*	12	102	56	45	45	M6704-1120AV	30246374
11,30	12	102	56	45	45	M6704-1130AV	30294580
11,40	12	102	56	45	45	M6704-1140AV	30294581
11,50	12	102	56	45	45	M6704-1150AV	30246375
11,60	12	102	56	45	45	M6704-1160AV	30294582
11,70	12	102	56	45	45	M6704-1170AV	30294583

## ECU-Drill-Uni | Vollhartmetall-Spiralbohrer M6704 (4xD), äußere Kühlmittelzufuhr

Baumaße						Schaftform HA	
d <sub>1</sub> m7	d <sub>2</sub> h6	l <sub>1</sub>	l <sub>2</sub>	l <sub>3</sub>	l <sub>4</sub>	Spezifikation	Bestell-Nr.
11,80	12	102	56	45	45	M6704-1180AV	30246376
12,00	12	102	56	45	45	M6704-1200AV	30246377
12,20	14	107	61	50	45	M6704-1220AV	30246378
12,50	14	107	61	50	45	M6704-1250AV	30246379
12,80	14	107	61	50	45	M6704-1280AV	30246380
13,00	14	107	61	50	45	M6704-1300AV	30246381
13,50	14	107	61	50	45	M6704-1350AV	30246382
13,80	14	107	61	50	45	M6704-1380AV	30246383
14,00	14	107	61	50	45	M6704-1400AV	30246384
14,20	16	115	65	51	48	M6704-1420AV	30246385
14,50	16	115	65	51	48	M6704-1450AV	30246386
14,80	16	115	65	51	48	M6704-1480AV	30246387
15,00	16	115	65	51	48	M6704-1500AV	30246388
15,10	16	115	65	51	48	M6704-1510AV	30246389
15,20	16	115	65	51	48	M6704-1520AV	30246390
15,50	16	115	65	51	48	M6704-1550AV	30246391
15,70	16	115	65	51	48	M6704-1570AV	30404969
15,80	16	115	65	51	48	M6704-1580AV	30246392
16,00	16	115	65	51	48	M6704-1600AV	30246393
16,50	18	123	73	53	48	M6704-1650AV	30246394
17,00	18	123	73	53	48	M6704-1700AV	30246395
17,50	18	123	73	53	48	M6704-1750AV	30246397
17,70	18	123	73	53	48	M6704-1770AV	30246398
18,00	18	123	73	53	48	M6704-1800AV	30246399
18,50	20	131	79	55	50	M6704-1850AV	30246400
19,00	20	131	79	55	50	M6704-1900AV	30246401
19,50	20	131	79	55	50	M6704-1950AV	30246403
20,00	20	131	79	55	50	M6704-2000AV	30246404

## Konfigurierbare Merkmale



**Schaftform:**  
Schaftform: HB | HE



**Spezifikation:**  
M6704-1500[Schaftform]V

Beispiel:  
M6704-1500EV

Schaftform HE

Maßangaben in mm.

\* Speziell zur Vorfertigung der Kernlöcher für Gewindeformer geeignet.

Schnittwertempfehlung siehe Kapitelende.

Sonderausführungen und andere Beschichtungen auf Anfrage.

# ECU-Drill-Uni

Vollhartmetall-Spiralbohrer  
M6806 (6xD), innere Kühlmittelzufuhr

**Ausführung:**

Bohrerdurchmesser: 3,00 - 20,00 mm  
Bohrungstoleranz:  $\geq$  IT 9  
Beschichtung: Mx5  
Schneidenanzahl: 2  
Spitzenwinkel: 140°  
Spiralwinkel: 30°

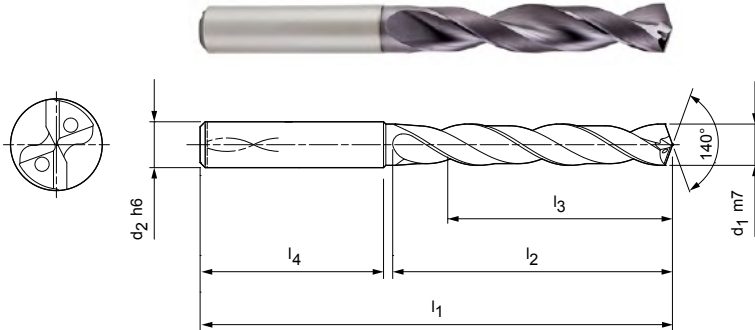

**Lagerhaltige Vorzugsbaureihe in Schaftform HA**

Baumaße						Schaftform HA	
d <sub>1</sub> m7	d <sub>2</sub> h6	l <sub>1</sub>	l <sub>2</sub>	l <sub>3</sub>	l <sub>4</sub>	Spezifikation	Bestell-Nr.
3,00	6	66	28	23	36	M6806-0300AV	30246513
3,10	6	66	28	23	36	M6806-0310AV	30246514
3,20	6	66	28	23	36	M6806-0320AV	30246515
3,30	6	66	28	23	36	M6806-0330AV	30246516
3,40	6	66	28	23	36	M6806-0340AV	30246517
3,50	6	66	28	23	36	M6806-0350AV	30246518
3,60	6	66	28	23	36	M6806-0360AV	30246519
3,70*	6	66	28	23	36	M6806-0370AV	30246520
3,80	6	74	36	29	36	M6806-0380AV	30246521
3,90	6	74	36	29	36	M6806-0390AV	30246522
4,00	6	74	36	29	36	M6806-0400AV	30246523
4,10	6	74	36	29	36	M6806-0410AV	30246524
4,20	6	74	36	29	36	M6806-0420AV	30246525
4,30	6	74	36	29	36	M6806-0430AV	30246526
4,40	6	74	36	29	36	M6806-0440AV	30246527
4,50	6	74	36	29	36	M6806-0450AV	30246528
4,60	6	74	36	29	36	M6806-0460AV	30246529
4,65*	6	74	36	29	36	M6806-0465AV	30296638
4,70	6	74	36	29	36	M6806-0470AV	30246530
4,80	6	82	44	35	36	M6806-0480AV	30246531
4,90	6	82	44	35	36	M6806-0490AV	30246532
5,00	6	82	44	35	36	M6806-0500AV	30246533
5,10	6	82	44	35	36	M6806-0510AV	30246534
5,20	6	82	44	35	36	M6806-0520AV	30246535
5,30	6	82	44	35	36	M6806-0530AV	30246536
5,40	6	82	44	35	36	M6806-0540AV	30246537
5,50	6	82	44	35	36	M6806-0550AV	30246538
5,55*	6	82	44	35	36	M6806-0555AV	30296639
5,60	6	82	44	35	36	M6806-0560AV	30246539
5,70	6	82	44	35	36	M6806-0570AV	30246540
5,80	6	82	44	35	36	M6806-0580AV	30246541
5,90	6	82	44	35	36	M6806-0590AV	30246542
6,00	6	82	44	35	36	M6806-0600AV	30246543
6,10	8	91	53	43	36	M6806-0610AV	30246544
6,20	8	91	53	43	36	M6806-0620AV	30246545

## ECU-Drill-Uni | Vollhartmetall-Spiralbohrer M6806 (6xD), innere Kühlmittelzufuhr

Baumaße						Schaftform HA	
d <sub>1</sub> m7	d <sub>2</sub> h6	l <sub>1</sub>	l <sub>2</sub>	l <sub>3</sub>	l <sub>4</sub>	Spezifikation	Bestell-Nr.
6,30	8	91	53	43	36	M6806-0630AV	30246546
6,40	8	91	53	43	36	M6806-0640AV	30246547
6,50	8	91	53	43	36	M6806-0650AV	30246548
6,60	8	91	53	43	36	M6806-0660AV	30246549
6,70	8	91	53	43	36	M6806-0670AV	30246550
6,80	8	91	53	43	36	M6806-0680AV	30246551
6,90	8	91	53	43	36	M6806-0690AV	30246552
7,00	8	91	53	43	36	M6806-0700AV	30246553
7,10	8	91	53	43	36	M6806-0710AV	30295483
7,20	8	91	53	43	36	M6806-0720AV	30295484
7,30	8	91	53	43	36	M6806-0730AV	30295485
7,40	8	91	53	43	36	M6806-0740AV	30246554
7,45*	8	91	53	43	36	M6806-0745AV	30530792
7,50	8	91	53	43	36	M6806-0750AV	30246555
7,60	8	91	53	43	36	M6806-0760AV	30295486
7,70	8	91	53	43	36	M6806-0770AV	30246556
7,80	8	91	53	43	36	M6806-0780AV	30246557
7,90	8	91	53	43	36	M6806-0790AV	30246558
8,00	8	91	53	43	36	M6806-0800AV	30246559
8,10	10	103	61	49	40	M6806-0810AV	30246560
8,20	10	103	61	49	40	M6806-0820AV	30246561
8,30	10	103	61	49	40	M6806-0830AV	30246562
8,40	10	103	61	49	40	M6806-0840AV	30295512
8,50	10	103	61	49	40	M6806-0850AV	30246563
8,60	10	103	61	49	40	M6806-0860AV	30246564
8,70	10	103	61	49	40	M6806-0870AV	30246565
8,80	10	103	61	49	40	M6806-0880AV	30246566
8,90	10	103	61	49	40	M6806-0890AV	30246567
9,00	10	103	61	49	40	M6806-0900AV	30246568
9,10	10	103	61	49	40	M6806-0910AV	30246569
9,20	10	103	61	49	40	M6806-0920AV	30295515
9,30*	10	103	61	49	40	M6806-0930AV	30246570
9,40	10	103	61	49	40	M6806-0940AV	30246571
9,50	10	103	61	49	40	M6806-0950AV	30246572
9,60	10	103	61	49	40	M6806-0960AV	30246573
9,70	10	103	61	49	40	M6806-0970AV	30295517
9,80	10	103	61	49	40	M6806-0980AV	30246574
9,90	10	103	61	49	40	M6806-0990AV	30246575
10,00	10	103	61	49	40	M6806-1000AV	30246576
10,10	12	118	71	56	45	M6806-1010AV	30246577
10,20	12	118	71	56	45	M6806-1020AV	30246578
10,30	12	118	71	56	45	M6806-1030AV	30294618
10,40	12	118	71	56	45	M6806-1040AV	30294619
10,50	12	118	71	56	45	M6806-1050AV	30246579
10,60	12	118	71	56	45	M6806-1060AV	30294620
10,70	12	118	71	56	45	M6806-1070AV	30294621
10,80	12	118	71	56	45	M6806-1080AV	30246580
10,90	12	118	71	56	45	M6806-1090AV	30294622
11,00	12	118	71	56	45	M6806-1100AV	30246581
11,10	12	118	71	56	45	M6806-1110AV	30294623
11,20*	12	118	71	56	45	M6806-1120AV	30246582
11,30	12	118	71	56	45	M6806-1130AV	30294624
11,50	12	118	71	56	45	M6806-1150AV	30246583
11,60	12	118	71	56	45	M6806-1160AV	30294626
11,80	12	118	71	56	45	M6806-1180AV	30246584
11,90	12	118	71	56	45	M6806-1190AV	30294628
12,00	12	118	71	56	45	M6806-1200AV	30246585

Fortsetzung auf nächster Seite.

## ECU-Drill-Uni | Vollhartmetall-Spiralbohrer M6806 (6xD), innere Kühlmittelzufuhr

Baumaße						Schaftform HA	
d <sub>1</sub> m7	d <sub>2</sub> h6	l <sub>1</sub>	l <sub>2</sub>	l <sub>3</sub>	l <sub>4</sub>	Spezifikation	Bestell-Nr.
12,20	14	124	77	60	45	M6806-1220AV	30246586
12,50	14	124	77	60	45	M6806-1250AV	30246587
12,70	14	124	77	60	45	M6806-1270AV	30303979
12,80	14	124	77	60	45	M6806-1280AV	30246588
13,00	14	124	77	60	45	M6806-1300AV	30246589
13,50	14	124	77	60	45	M6806-1350AV	30246590
13,70	14	124	77	60	45	M6806-1370AV	30303980
13,80	14	124	77	60	45	M6806-1380AV	30246591
14,00	14	124	77	60	45	M6806-1400AV	30246592
14,20	16	133	83	63	48	M6806-1420AV	30246593
14,50	16	133	83	63	48	M6806-1450AV	30246594
14,80	16	133	83	63	48	M6806-1480AV	30246595
15,00	16	133	83	63	48	M6806-1500AV	30246596
15,50	16	133	83	63	48	M6806-1550AV	30246598
15,70	16	133	83	63	48	M6806-1570AV	30303981
15,80	16	133	83	63	48	M6806-1580AV	30246599
16,00	16	133	83	63	48	M6806-1600AV	30246600
16,50	18	143	93	71	48	M6806-1650AV	30246601
17,00	18	143	93	71	48	M6806-1700AV	30246602
17,50	18	143	93	71	48	M6806-1750AV	30246603
18,00	18	143	93	71	48	M6806-1800AV	30246604
18,50	20	153	101	77	50	M6806-1850AV	30246605
19,00	20	153	101	77	50	M6806-1900AV	30246606
19,50	20	153	101	77	50	M6806-1950AV	30246607
20,00	20	153	101	77	50	M6806-2000AV	30246608

## Konfigurierbare Merkmale



**Schaftform:**  
Schaftform: HB | HE



**Spezifikation:**  
M6806-1500[Schaftform]V

Beispiel:  
M6806-1500EV

Schaftform HE

Maßangaben in mm.

\* Speziell zur Vorfertigung der Kernlöcher für Gewindeformer geeignet.

Schnittwertempfehlung siehe Kapitelende.

Sonderausführungen und andere Beschichtungen auf Anfrage.



# MEGA-Drill-Steel-Plus

Vollhartmetall-Spiralbohrer

M2003P (3xD), äußere Kühlmittelzufuhr, Nachfolgeprodukt des MEGA-Drill-Steel (M2003)

**Ausführung:**

Bohrerdurchmesser: 3,00 - 25,00 mm  
 Bohrungstoleranz:  $\geq$  IT 9  
 Beschichtung: MxP  
 Schneidanzahl: 2  
 Anzahl Führungsfasen: 2  
 Spitzenwinkel: 140°  
 Spiralwinkel: 30°

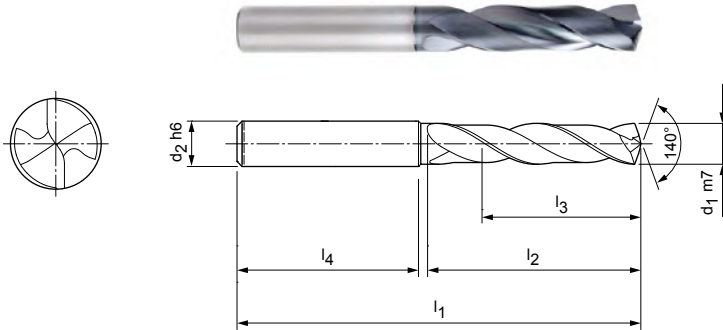

**Lagerhaltige Vorzugsbaureihe in Schaftform HA**

Baumaße						Schaftform HA	
d <sub>1</sub> m7	d <sub>2</sub> h6	l <sub>1</sub>	l <sub>2</sub>	l <sub>3</sub>	l <sub>4</sub>	Spezifikation	Bestell-Nr.
3,00	6	62	20	14	36	M2003P-0300AR	30683755
3,10	6	62	20	14	36	M2003P-0310AR	30683756
3,15	6	62	20	14	36	M2003P-0315AR	30683757
3,20	6	62	20	14	36	M2003P-0320AR	30683759
3,25	6	62	20	14	36	M2003P-0325AR	30683761
3,30	6	62	20	14	36	M2003P-0330AR	30683762
3,40	6	62	20	14	36	M2003P-0340AR	30683763
3,50	6	62	20	14	36	M2003P-0350AR	30683764
3,60	6	62	20	14	36	M2003P-0360AR	30683765
3,70*	6	62	20	14	36	M2003P-0370AR	30683766
3,80	6	66	24	17	36	M2003P-0380AR	30683767
3,85	6	66	24	17	36	M2003P-0385AR	30683768
3,90	6	66	24	17	36	M2003P-0390AR	30683769
4,00	6	66	24	17	36	M2003P-0400AR	30683770
4,10	6	66	24	17	36	M2003P-0410AR	30683771
4,20	6	66	24	17	36	M2003P-0420AR	30683772
4,25	6	66	24	17	36	M2003P-0425AR	30683773
4,30	6	66	24	17	36	M2003P-0430AR	30683774
4,35	6	66	24	17	36	M2003P-0435AR	30683775
4,40	6	66	24	17	36	M2003P-0440AR	30683776
4,45	6	66	24	17	36	M2003P-0445AR	30683777
4,50	6	66	24	17	36	M2003P-0450AR	30683778
4,60	6	66	24	17	36	M2003P-0460AR	30683779
4,65*	6	66	24	17	36	M2003P-0465AR	30683780
4,70	6	66	24	17	36	M2003P-0470AR	30683781
4,80	6	66	28	20	36	M2003P-0480AR	30683782
4,90	6	66	28	20	36	M2003P-0490AR	30683783
4,95	6	66	28	20	36	M2003P-0495AR	30683784
5,00	6	66	28	20	36	M2003P-0500AR	30683785
5,05	6	66	28	20	36	M2003P-0505AR	30683786
5,10	6	66	28	20	36	M2003P-0510AR	30683787
5,20	6	66	28	20	36	M2003P-0520AR	30683788
5,30	6	66	28	20	36	M2003P-0530AR	30683789
5,40	6	66	28	20	36	M2003P-0540AR	30683790
5,50	6	66	28	20	36	M2003P-0550AR	30683791

## MEGA-Drill-Steel-Plus | Vollhartmetall-Spiralbohrer M2003P (3xD), äußere Kühlmittelzufuhr

Baumaße						Schaftform HA	
d <sub>1</sub> m7	d <sub>2</sub> h6	l <sub>1</sub>	l <sub>2</sub>	l <sub>3</sub>	l <sub>4</sub>	Spezifikation	Bestell-Nr.
5,55*	6	66	28	20	36	M2003P-0555AR	30683792
5,60	6	66	28	20	36	M2003P-0560AR	30683793
5,70	6	66	28	20	36	M2003P-0570AR	30683794
5,75	6	66	28	20	36	M2003P-0575AR	30683795
5,80	6	66	28	20	36	M2003P-0580AR	30683796
5,90	6	66	28	20	36	M2003P-0590AR	30683797
5,95	6	66	28	20	36	M2003P-0595AR	30683798
6,00	6	66	28	20	36	M2003P-0600AR	30683799
6,10	8	79	34	24	36	M2003P-0610AR	30683800
6,20	8	79	34	24	36	M2003P-0620AR	30683801
6,30	8	79	34	24	36	M2003P-0630AR	30683802
6,40	8	79	34	24	36	M2003P-0640AR	30683803
6,50	8	79	34	24	36	M2003P-0650AR	30683804
6,60	8	79	34	24	36	M2003P-0660AR	30683805
6,70	8	79	34	24	36	M2003P-0670AR	30683806
6,80	8	79	34	24	36	M2003P-0680AR	30683807
6,90	8	79	34	24	36	M2003P-0690AR	30683808
7,00	8	79	34	24	36	M2003P-0700AR	30683809
7,10	8	79	41	29	36	M2003P-0710AR	30683810
7,20	8	79	41	29	36	M2003P-0720AR	30683811
7,30	8	79	41	29	36	M2003P-0730AR	30683812
7,40	8	79	41	29	36	M2003P-0740AR	30683813
7,45*	8	79	41	29	36	M2003P-0745AR	30683814
7,50	8	79	41	29	36	M2003P-0750AR	30683815
7,60	8	79	41	29	36	M2003P-0760AR	30683816
7,70	8	79	41	29	36	M2003P-0770AR	30683817
7,80	8	79	41	29	36	M2003P-0780AR	30683818
7,90	8	79	41	29	36	M2003P-0790AR	30683819
8,00	8	79	41	29	36	M2003P-0800AR	30683820
8,10	10	89	47	35	40	M2003P-0810AR	30683821
8,20	10	89	47	35	40	M2003P-0820AR	30683822
8,30	10	89	47	35	40	M2003P-0830AR	30683823
8,40	10	89	47	35	40	M2003P-0840AR	30683824
8,50	10	89	47	35	40	M2003P-0850AR	30683825
8,60	10	89	47	35	40	M2003P-0860AR	30683827
8,70	10	89	47	35	40	M2003P-0870AR	30683828
8,80	10	89	47	35	40	M2003P-0880AR	30683829
8,90	10	89	47	35	40	M2003P-0890AR	30683830
9,00	10	89	47	35	40	M2003P-0900AR	30683831
9,10	10	89	47	35	40	M2003P-0910AR	30683832
9,20	10	89	47	35	40	M2003P-0920AR	30683833
9,30*	10	89	47	35	40	M2003P-0930AR	30683834
9,35	10	89	47	35	40	M2003P-0935AR	30683835
9,50	10	89	47	35	40	M2003P-0950AR	30683838
9,60	10	89	47	35	40	M2003P-0960AR	30683839
9,70	10	89	47	35	40	M2003P-0970AR	30683840
9,80	10	89	47	35	40	M2003P-0980AR	30683841
9,90	10	89	47	35	40	M2003P-0990AR	30683842
10,00	10	89	47	35	40	M2003P-1000AR	30683843
10,10	12	102	55	40	45	M2003P-1010AR	30683844
10,20	12	102	55	40	45	M2003P-1020AR	30683845
10,30	12	102	55	40	45	M2003P-1030AR	30683846
10,40	12	102	55	40	45	M2003P-1040AR	30683847
10,50	12	102	55	40	45	M2003P-1050AR	30683848
10,55	12	102	55	40	45	M2003P-1055AR	30683849
10,60	12	102	55	40	45	M2003P-1060AR	30683850
10,70	12	102	55	40	45	M2003P-1070AR	30683851

**MEGA-Drill-Steel-Plus | Vollhartmetall-Spiralbohrer M2003P (3xD), äußere Kühlmittelzufuhr**

Baumaße						Schaftform HA	
d <sub>1</sub> m7	d <sub>2</sub> h6	l <sub>1</sub>	l <sub>2</sub>	l <sub>3</sub>	l <sub>4</sub>	Spezifikation	Bestell-Nr.
10,80	12	102	55	40	45	M2003P-1080AR	30683853
10,90	12	102	55	40	45	M2003P-1090AR	30683854
11,00	12	102	55	40	45	M2003P-1100AR	30683855
11,10	12	102	55	40	45	M2003P-1110AR	30683856
11,20*	12	102	55	40	45	M2003P-1120AR	30683857
11,25	12	102	55	40	45	M2003P-1125AR	30683858
11,30	12	102	55	40	45	M2003P-1130AR	30683859
11,35	12	102	55	40	45	M2003P-1135AR	30683860
11,40	12	102	55	40	45	M2003P-1140AR	30683861
11,50	12	102	55	40	45	M2003P-1150AR	30683863
11,60	12	102	55	40	45	M2003P-1160AR	30683864
11,70	12	102	55	40	45	M2003P-1170AR	30683865
11,80	12	102	55	40	45	M2003P-1180AR	30683866
11,90	12	102	55	40	45	M2003P-1190AR	30683867
12,00	12	102	55	40	45	M2003P-1200AR	30683868
12,15	14	107	60	43	45	M2003P-1215AR	30683869
12,25	14	107	60	43	45	M2003P-1225AR	30683870
12,50	14	107	60	43	45	M2003P-1250AR	30683871
12,55	14	107	60	43	45	M2003P-1255AR	30683872
12,70	14	107	60	43	45	M2003P-1270AR	30683873
12,80	14	107	60	43	45	M2003P-1280AR	30683874
13,00	14	107	60	43	45	M2003P-1300AR	30683876
13,10	14	107	60	43	45	M2003P-1310AR	30683877
13,30	14	107	60	43	45	M2003P-1330AR	30683878
13,35	14	107	60	43	45	M2003P-1335AR	30683879
13,50	14	107	60	43	45	M2003P-1350AR	30683880
13,70	14	107	60	43	45	M2003P-1370AR	30683881
13,80	14	107	60	43	45	M2003P-1380AR	30683882
14,00	14	107	60	43	45	M2003P-1400AR	30683883
14,20	16	115	65	45	48	M2003P-1420AR	30683884
14,50	16	115	65	45	48	M2003P-1450AR	30683885
14,80	16	115	65	45	48	M2003P-1480AR	30683886
15,00	16	115	65	45	48	M2003P-1500AR	30683887
15,10	16	115	65	45	48	M2003P-1510AR	30683888
15,25	16	115	65	45	48	M2003P-1525AR	30683889
15,30	16	115	65	45	48	M2003P-1530AR	30683890
15,35	16	115	65	45	48	M2003P-1535AR	30683891
15,50	16	115	65	45	48	M2003P-1550AR	30683892
15,60	16	115	65	45	48	M2003P-1560AR	30683893
15,80	16	115	65	45	48	M2003P-1580AR	30683894
16,00	16	115	65	45	48	M2003P-1600AR	30683895
16,05	18	123	73	51	48	M2003P-1605AR	30683896
16,50	18	123	73	51	48	M2003P-1650AR	30683897
16,80	18	123	73	51	48	M2003P-1680AR	30683898
17,00	18	123	73	51	48	M2003P-1700AR	30683901
17,50	18	123	73	51	48	M2003P-1750AR	30683902
17,80	18	123	73	51	48	M2003P-1780AR	30683904
18,00	18	123	73	51	48	M2003P-1800AR	30683905
18,50	20	131	79	55	50	M2003P-1850AR	30683906
19,00	20	131	79	55	50	M2003P-1900AR	30683909
19,35	20	131	79	55	50	M2003P-1935AR	30683910
19,60	20	131	79	55	50	M2003P-1960AR	30683912
19,80	20	131	79	55	50	M2003P-1980AR	30683913
20,00	20	131	79	55	50	M2003P-2000AR	30683914

Fortsetzung auf nächster Seite.

## MEGA-Drill-Steel-Plus | Vollhartmetall-Spiralbohrer M2003P (3xD), äußere Kühlmittelzufuhr

## Konfigurierbare Merkmale

**Durchmesser:**

Durchmesser in Abstufungen  
von 0,01 mm frei wählbar

**Schaftform:**

Schaftform: HB | HE

**Spezifikation:**

M2003P-[Durchmesser][Schaftform]R

**Beispiel:**

M2003P-0431ER

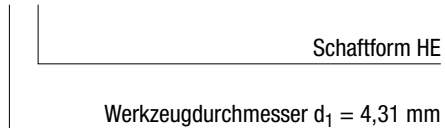

## Abmessungen konfigurierbare Baureihe

d <sub>1</sub> min.	d <sub>1</sub> max.	d <sub>2</sub> h6	l <sub>1</sub>	l <sub>2</sub>	l <sub>3</sub>	l <sub>4</sub>
3,00	3,70	6	62	20	14	36
3,71	4,70	6	66	24	17	36
4,71	6,00	6	66	28	20	36
6,01	7,00	8	79	34	24	36
7,01	8,00	8	79	41	29	36
8,01	10,00	10	89	47	35	40
10,01	12,00	12	102	55	40	45
12,01	14,00	14	107	60	43	45
14,01	16,00	16	115	65	45	48
16,01	18,00	18	123	73	51	48
18,01	20,00	20	131	79	55	50
20,01	22,00	25	151	93	66	56
22,01	25,00	25	153	96	72	56

Maßangaben in mm.

\* Speziell zur Vorfertigung der Kernlöcher für Gewindeformer geeignet.

Schnittwertempfehlung siehe Kapitelende.

Sonderausführungen und andere Beschichtungen auf Anfrage.

# MEGA-Drill-Steel-Plus

Vollhartmetall-Spiralbohrer

M2103P (3xD), innere Kühlmittelzufuhr, Nachfolgeprodukt des MEGA-Drill-Steel (M2103)

**Ausführung:**

Bohrerdurchmesser: 3,00 - 25,00 mm  
 Bohrungstoleranz:  $\geq$  IT 9  
 Beschichtung: MxP  
 Schneidanzahl: 2  
 Anzahl Führungsfasen: 2  
 Spitzenwinkel: 140°  
 Spiralwinkel: 30°

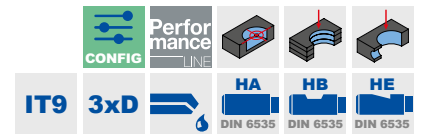
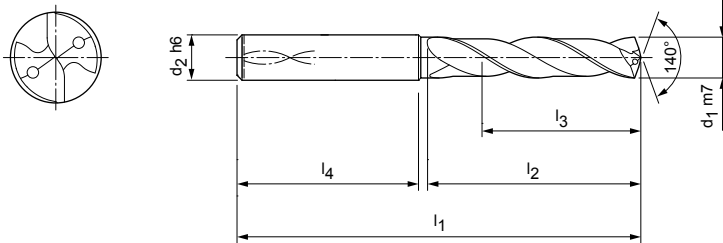

**Lagerhaltige Vorzugsbaureihe in Schaftform HA**

Baumaße						Schaftform HA	
d <sub>1</sub> m7	d <sub>2</sub> h6	l <sub>1</sub>	l <sub>2</sub>	l <sub>3</sub>	l <sub>4</sub>	Spezifikation	Bestell-Nr.
3,00	6	62	20	14	36	M2103P-0300AR	30682354
3,10	6	62	20	14	36	M2103P-0310AR	30682355
3,15	6	62	20	14	36	M2103P-0315AR	30682356
3,20	6	62	20	14	36	M2103P-0320AR	30682357
3,22	6	62	20	14	36	M2103P-0322AR	30682358
3,25	6	62	20	14	36	M2103P-0325AR	30682359
3,30	6	62	20	14	36	M2103P-0330AR	30682360
3,40	6	62	20	14	36	M2103P-0340AR	30682361
3,50	6	62	20	14	36	M2103P-0350AR	30682362
3,60	6	62	20	14	36	M2103P-0360AR	30682363
3,70*	6	62	20	14	36	M2103P-0370AR	30682364
3,80	6	66	24	17	36	M2103P-0380AR	30682365
3,85	6	66	24	17	36	M2103P-0385AR	30682366
3,90	6	66	24	17	36	M2103P-0390AR	30682367
4,00	6	66	24	17	36	M2103P-0400AR	30682368
4,10	6	66	24	17	36	M2103P-0410AR	30682369
4,20	6	66	24	17	36	M2103P-0420AR	30682370
4,25	6	66	24	17	36	M2103P-0425AR	30682371
4,30	6	66	24	17	36	M2103P-0430AR	30682372
4,40	6	66	24	17	36	M2103P-0440AR	30682374
4,50	6	66	24	17	36	M2103P-0450AR	30682376
4,60	6	66	24	17	36	M2103P-0460AR	30682377
4,65*	6	66	24	17	36	M2103P-0465AR	30682378
4,70	6	66	24	17	36	M2103P-0470AR	30682379
4,80	6	66	28	20	36	M2103P-0480AR	30682380
4,90	6	66	28	20	36	M2103P-0490AR	30682381
4,95	6	66	28	20	36	M2103P-0495AR	30682382
5,00	6	66	28	20	36	M2103P-0500AR	30682383
5,05	6	66	28	20	36	M2103P-0505AR	30682384
5,10	6	66	28	20	36	M2103P-0510AR	30682385
5,20	6	66	28	20	36	M2103P-0520AR	30682386
5,30	6	66	28	20	36	M2103P-0530AR	30682387
5,40	6	66	28	20	36	M2103P-0540AR	30682388
5,50	6	66	28	20	36	M2103P-0550AR	30682389
5,55*	6	66	28	20	36	M2103P-0555AR	30682390

## MEGA-Drill-Steel-Plus | Vollhartmetall-Spiralbohrer M2103P (3xD), innere Kühlmittelzufuhr

Baumaße						Schaftform HA	
d <sub>1</sub> m7	d <sub>2</sub> h6	l <sub>1</sub>	l <sub>2</sub>	l <sub>3</sub>	l <sub>4</sub>	Spezifikation	Bestell-Nr.
5,60	6	66	28	20	36	M2103P-0560AR	30682391
5,70	6	66	28	20	36	M2103P-0570AR	30682392
5,75	6	66	28	20	36	M2103P-0575AR	30682393
5,80	6	66	28	20	36	M2103P-0580AR	30682394
5,90	6	66	28	20	36	M2103P-0590AR	30682395
5,95	6	66	28	20	36	M2103P-0595AR	30682396
6,00	6	66	28	20	36	M2103P-0600AR	30682397
6,10	8	79	34	24	36	M2103P-0610AR	30682398
6,20	8	79	34	24	36	M2103P-0620AR	30682399
6,30	8	79	34	24	36	M2103P-0630AR	30682400
6,40	8	79	34	24	36	M2103P-0640AR	30682401
6,50	8	79	34	24	36	M2103P-0650AR	30682402
6,60	8	79	34	24	36	M2103P-0660AR	30682403
6,70	8	79	34	24	36	M2103P-0670AR	30682404
6,80	8	79	34	24	36	M2103P-0680AR	30682405
6,90	8	79	34	24	36	M2103P-0690AR	30682406
7,00	8	79	34	24	36	M2103P-0700AR	30682407
7,10	8	79	41	29	36	M2103P-0710AR	30682408
7,20	8	79	41	29	36	M2103P-0720AR	30682409
7,30	8	79	41	29	36	M2103P-0730AR	30682410
7,40	8	79	41	29	36	M2103P-0740AR	30682411
7,45*	8	79	41	29	36	M2103P-0745AR	30682412
7,50	8	79	41	29	36	M2103P-0750AR	30682414
7,60	8	79	41	29	36	M2103P-0760AR	30682415
7,70	8	79	41	29	36	M2103P-0770AR	30682416
7,80	8	79	41	29	36	M2103P-0780AR	30682417
7,90	8	79	41	29	36	M2103P-0790AR	30682418
8,00	8	79	41	29	36	M2103P-0800AR	30682419
8,10	10	89	47	35	40	M2103P-0810AR	30682420
8,20	10	89	47	35	40	M2103P-0820AR	30682421
8,30	10	89	47	35	40	M2103P-0830AR	30682422
8,40	10	89	47	35	40	M2103P-0840AR	30682423
8,50	10	89	47	35	40	M2103P-0850AR	30682424
8,60	10	89	47	35	40	M2103P-0860AR	30682425
8,70	10	89	47	35	40	M2103P-0870AR	30682426
8,80	10	89	47	35	40	M2103P-0880AR	30682427
8,90	10	89	47	35	40	M2103P-0890AR	30682428
9,00	10	89	47	35	40	M2103P-0900AR	30682429
9,10	10	89	47	35	40	M2103P-0910AR	30682430
9,20	10	89	47	35	40	M2103P-0920AR	30682431
9,30*	10	89	47	35	40	M2103P-0930AR	30682432
9,35	10	89	47	35	40	M2103P-0935AR	30682433
9,40	10	89	47	35	40	M2103P-0940AR	30682434
9,50	10	89	47	35	40	M2103P-0950AR	30682436
9,60	10	89	47	35	40	M2103P-0960AR	30682437
9,70	10	89	47	35	40	M2103P-0970AR	30682438
9,80	10	89	47	35	40	M2103P-0980AR	30682439
9,90	10	89	47	35	40	M2103P-0990AR	30682440
10,00	10	89	47	35	40	M2103P-1000AR	30682441
10,10	12	102	55	40	45	M2103P-1010AR	30682442
10,20	12	102	55	40	45	M2103P-1020AR	30682443
10,30	12	102	55	40	45	M2103P-1030AR	30682444
10,40	12	102	55	40	45	M2103P-1040AR	30682445
10,50	12	102	55	40	45	M2103P-1050AR	30682446
10,55	12	102	55	40	45	M2103P-1055AR	30682447
10,60	12	102	55	40	45	M2103P-1060AR	30682448
10,70	12	102	55	40	45	M2103P-1070AR	30682449

## MEGA-Drill-Steel-Plus | Vollhartmetall-Spiralbohrer M2103P (3xD), innere Kühlmittelzufuhr

Baumaße						Schaftform HA	
d <sub>1</sub> m7	d <sub>2</sub> h6	l <sub>1</sub>	l <sub>2</sub>	l <sub>3</sub>	l <sub>4</sub>	Spezifikation	Bestell-Nr.
10,75	12	102	55	40	45	M2103P-1075AR	30682450
10,80	12	102	55	40	45	M2103P-1080AR	30682451
10,90	12	102	55	40	45	M2103P-1090AR	30682452
11,00	12	102	55	40	45	M2103P-1100AR	30682453
11,10	12	102	55	40	45	M2103P-1110AR	30682454
11,20*	12	102	55	40	45	M2103P-1120AR	30682455
11,25	12	102	55	40	45	M2103P-1125AR	30682456
11,30	12	102	55	40	45	M2103P-1130AR	30682457
11,45	12	102	55	40	45	M2103P-1145AR	30682460
11,50	12	102	55	40	45	M2103P-1150AR	30682461
11,60	12	102	55	40	45	M2103P-1160AR	30682462
11,70	12	102	55	40	45	M2103P-1170AR	30682463
11,80	12	102	55	40	45	M2103P-1180AR	30682464
11,90	12	102	55	40	45	M2103P-1190AR	30682465
12,00	12	102	55	40	45	M2103P-1200AR	30682466
12,15	14	107	60	43	45	M2103P-1215AR	30682467
12,20	14	107	60	43	45	M2103P-1220AR	30787358
12,25	14	107	60	43	45	M2103P-1225AR	30682468
12,50	14	107	60	43	45	M2103P-1250AR	30682469
12,55	14	107	60	43	45	M2103P-1255AR	30682470
12,70	14	107	60	43	45	M2103P-1270AR	30682471
12,80	14	107	60	43	45	M2103P-1280AR	30682472
12,90	14	107	60	43	45	M2103P-1290AR	30682473
13,00	14	107	60	43	45	M2103P-1300AR	30682474
13,10	14	107	60	43	45	M2103P-1310AR	30682475
13,30	14	107	60	43	45	M2103P-1330AR	30682476
13,35	14	107	60	43	45	M2103P-1335AR	30682477
13,50	14	107	60	43	45	M2103P-1350AR	30682478
13,70	14	107	60	43	45	M2103P-1370AR	30682479
13,80	14	107	60	43	45	M2103P-1380AR	30682480
14,00	14	107	60	43	45	M2103P-1400AR	30682481
14,20	16	115	65	45	48	M2103P-1420AR	30682482
14,50	16	115	65	45	48	M2103P-1450AR	30682483
14,80	16	115	65	45	48	M2103P-1480AR	30682484
15,00	16	115	65	45	48	M2103P-1500AR	30682485
15,10	16	115	65	45	48	M2103P-1510AR	30682486
15,25	16	115	65	45	48	M2103P-1525AR	30682487
15,30	16	115	65	45	48	M2103P-1530AR	30682488
15,35	16	115	65	45	48	M2103P-1535AR	30682489
15,50	16	115	65	45	48	M2103P-1550AR	30682490
15,60	16	115	65	45	48	M2103P-1560AR	30682491
15,80	16	115	65	45	48	M2103P-1580AR	30682492
16,00	16	115	65	45	48	M2103P-1600AR	30682493
16,05	18	123	73	51	48	M2103P-1605AR	30682494
16,50	18	123	73	51	48	M2103P-1650AR	30682495
16,60	18	123	73	51	48	M2103P-1660AR	31256304
16,90	18	123	73	51	48	M2103P-1690AR	30682497
17,00	18	123	73	51	48	M2103P-1700AR	30682498
17,50	18	123	73	51	48	M2103P-1750AR	30682499
17,60	18	123	73	51	48	M2103P-1760AR	30682500
17,80	18	123	73	51	48	M2103P-1780AR	30682501
18,00	18	123	73	51	48	M2103P-1800AR	30682502
18,50	20	131	79	55	50	M2103P-1850AR	30682503
18,90	20	131	79	55	50	M2103P-1890AR	30682505
19,00	20	131	79	55	50	M2103P-1900AR	30682506
19,35	20	131	79	55	50	M2103P-1935AR	30682507
19,50	20	131	79	55	50	M2103P-1950AR	30682508

Fortsetzung auf nächster Seite.

## MEGA-Drill-Steel-Plus | Vollhartmetall-Spiralbohrer M2103P (3xD), innere Kühlmittelzufuhr

Baumaße						Schaftform HA	
d <sub>1</sub> m7	d <sub>2</sub> h6	l <sub>1</sub>	l <sub>2</sub>	l <sub>3</sub>	l <sub>4</sub>	Spezifikation	Bestell-Nr.
19,80	20	131	79	55	50	M2103P-1980AR	30682510
20,00	20	131	79	55	50	M2103P-2000AR	30682511
21,00	25	151	93	66	56	M2103P-2100AR	30682514
21,50	25	151	93	66	56	M2103P-2150AR	30682515
22,00	25	151	93	66	56	M2103P-2200AR	30682516
23,50	25	151	93	66	56	M2103P-2350AR	30682519

## Konfigurierbare Merkmale

**Durchmesser:**

Durchmesser in Abstufungen  
von 0,01 mm frei wählbar

**Schaftform:**

Schaftform: HB | HE

**Spezifikation:**

M2103P-[Durchmesser][Schaftform]R

**Beispiel:**  
M2103P-0431ER

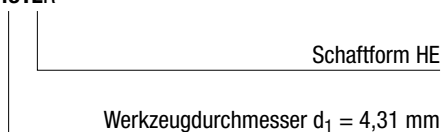

## Abmessungen konfigurierbare Baureihe

d <sub>1</sub> min.	d <sub>1</sub> max.	d <sub>2</sub> h6	l <sub>1</sub>	l <sub>2</sub>	l <sub>3</sub>	l <sub>4</sub>
3,00	3,70	6	62	20	14	36
3,71	4,70	6	66	24	17	36
4,71	6,00	6	66	28	20	36
6,01	7,00	8	79	34	24	36
7,01	8,00	8	79	41	29	36
8,01	10,00	10	89	47	35	40
10,01	12,00	12	102	55	40	45
12,01	14,00	14	107	60	43	45
14,01	16,00	16	115	65	45	48
16,01	18,00	18	123	73	51	48
18,01	20,00	20	131	79	55	50
20,01	25,00	25	151	93	66	56

Maßangaben in mm.

\* Speziell zur Vorfertigung der Kernlöcher für Gewindeformer geeignet.

Schnittwertempfehlung siehe Kapitelende.

Sonderausführungen und andere Beschichtungen auf Anfrage.



# MEGA-Drill-Steel-Plus

Vollhartmetall-Spiralbohrer

M2005P (5xD), äußere Kühlmittelzufuhr, Nachfolgeprodukt des MEGA-Drill-Steel (M2005)

**Ausführung:**

Bohrerdurchmesser: 3,00 - 20,00 mm  
 Bohrungstoleranz: ≥ IT 9  
 Beschichtung: MxP  
 Schneidanzahl: 2  
 Anzahl Führungsfasen: 2  
 Spitzenwinkel: 140°  
 Spiralwinkel: 30°

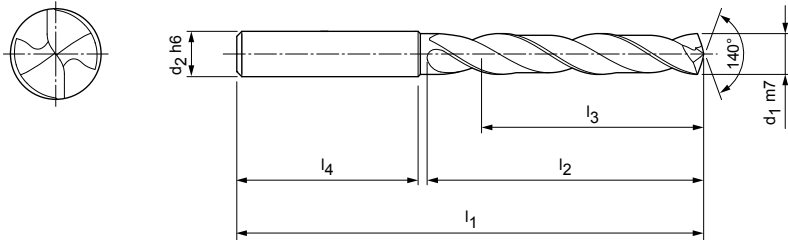

**Lagerhaltige Vorzugsbaureihe in Schaftform HA**

Baumaße						Schaftform HA	
d <sub>1</sub> m7	d <sub>2</sub> h6	l <sub>1</sub>	l <sub>2</sub>	l <sub>3</sub>	l <sub>4</sub>	Spezifikation	Bestell-Nr.
3,00	6	66	28	23	36	M2005P-0300AR	30684264
3,10	6	66	28	23	36	M2005P-0310AR	30684265
3,15	6	66	28	23	36	M2005P-0315AR	30684266
3,20	6	66	28	23	36	M2005P-0320AR	30684267
3,25	6	66	28	23	36	M2005P-0325AR	30684269
3,30	6	66	28	23	36	M2005P-0330AR	30684270
3,40	6	66	28	23	36	M2005P-0340AR	30684271
3,50	6	66	28	23	36	M2005P-0350AR	30684272
3,60	6	66	28	23	36	M2005P-0360AR	30684273
3,70	6	66	28	23	36	M2005P-0370AR	30684274
3,80	6	74	36	29	36	M2005P-0380AR	30684275
3,90	6	74	36	29	36	M2005P-0390AR	30684277
4,00	6	74	36	29	36	M2005P-0400AR	30684278
4,10	6	74	36	29	36	M2005P-0410AR	30684279
4,20	6	74	36	29	36	M2005P-0420AR	30684280
4,25	6	74	36	29	36	M2005P-0425AR	30684281
4,30	6	74	36	29	36	M2005P-0430AR	30684282
4,35	6	74	36	29	36	M2005P-0435AR	30684283
4,40	6	74	36	29	36	M2005P-0440AR	30684285
4,50	6	74	36	29	36	M2005P-0450AR	30684287
4,60	6	74	36	29	36	M2005P-0460AR	30684288
4,65	6	74	36	29	36	M2005P-0465AR	30684289
4,70	6	74	36	29	36	M2005P-0470AR	30684290
4,80	6	82	44	35	36	M2005P-0480AR	30684291
4,90	6	82	44	35	36	M2005P-0490AR	30684292
4,95	6	82	44	35	36	M2005P-0495AR	30684293
5,00	6	82	44	35	36	M2005P-0500AR	30684294
5,05	6	82	44	35	36	M2005P-0505AR	30684295
5,10	6	82	44	35	36	M2005P-0510AR	30684296
5,20	6	82	44	35	36	M2005P-0520AR	30684297
5,30	6	82	44	35	36	M2005P-0530AR	30684298
5,40	6	82	44	35	36	M2005P-0540AR	30684299
5,50	6	82	44	35	36	M2005P-0550AR	30684300
5,55	6	82	44	35	36	M2005P-0555AR	30684301
5,60	6	82	44	35	36	M2005P-0560AR	30684302

## MEGA-Drill-Steel-Plus | Vollhartmetall-Spiralbohrer M2005P (5xD), äußere Kühlmittelzufuhr

Baumaße						Schaftform HA	
d <sub>1</sub> m7	d <sub>2</sub> h6	l <sub>1</sub>	l <sub>2</sub>	l <sub>3</sub>	l <sub>4</sub>	Spezifikation	Bestell-Nr.
5,70	6	82	44	35	36	M2005P-0570AR	30684303
5,75	6	82	44	35	36	M2005P-0575AR	30684304
5,80	6	82	44	35	36	M2005P-0580AR	30684305
5,90	6	82	44	35	36	M2005P-0590AR	30684306
5,95	6	82	44	35	36	M2005P-0595AR	30684307
6,00	6	82	44	35	36	M2005P-0600AR	30684308
6,10	8	91	53	43	36	M2005P-0610AR	30684309
6,20	8	91	53	43	36	M2005P-0620AR	30684310
6,30	8	91	53	43	36	M2005P-0630AR	30684311
6,40	8	91	53	43	36	M2005P-0640AR	30684312
6,50	8	91	53	43	36	M2005P-0650AR	30684313
6,60	8	91	53	43	36	M2005P-0660AR	30684314
6,70	8	91	53	43	36	M2005P-0670AR	30684315
6,80	8	91	53	43	36	M2005P-0680AR	30684316
6,90	8	91	53	43	36	M2005P-0690AR	30684317
7,00	8	91	53	43	36	M2005P-0700AR	30684318
7,10	8	91	53	43	36	M2005P-0710AR	30684319
7,20	8	91	53	43	36	M2005P-0720AR	30684320
7,30	8	91	53	43	36	M2005P-0730AR	30684321
7,40	8	91	53	43	36	M2005P-0740AR	30684322
7,45	8	91	53	43	36	M2005P-0745AR	30684323
7,50	8	91	53	43	36	M2005P-0750AR	30684324
7,60	8	91	53	43	36	M2005P-0760AR	30684325
7,80	8	91	53	43	36	M2005P-0780AR	30684327
7,90	8	91	53	43	36	M2005P-0790AR	30684328
8,00	8	91	53	43	36	M2005P-0800AR	30684329
8,10	10	103	61	49	40	M2005P-0810AR	30684330
8,20	10	103	61	49	40	M2005P-0820AR	30684331
8,30	10	103	61	49	40	M2005P-0830AR	30684332
8,40	10	103	61	49	40	M2005P-0840AR	30684333
8,50	10	103	61	49	40	M2005P-0850AR	30684334
8,60	10	103	61	49	40	M2005P-0860AR	30684335
8,70	10	103	61	49	40	M2005P-0870AR	30684336
8,80	10	103	61	49	40	M2005P-0880AR	30684337
8,90	10	103	61	49	40	M2005P-0890AR	30684338
9,00	10	103	61	49	40	M2005P-0900AR	30684339
9,10	10	103	61	49	40	M2005P-0910AR	30684340
9,20	10	103	61	49	40	M2005P-0920AR	30684341
9,30	10	103	61	49	40	M2005P-0930AR	30684342
9,50	10	103	61	49	40	M2005P-0950AR	30684346
9,60	10	103	61	49	40	M2005P-0960AR	30684347
9,70	10	103	61	49	40	M2005P-0970AR	30684348
9,80	10	103	61	49	40	M2005P-0980AR	30684349
9,90	10	103	61	49	40	M2005P-0990AR	30684350
10,00	10	103	61	49	40	M2005P-1000AR	30684351
10,10	12	118	71	56	45	M2005P-1010AR	30684352
10,20	12	118	71	56	45	M2005P-1020AR	30684353
10,30	12	118	71	56	45	M2005P-1030AR	30684354
10,40	12	118	71	56	45	M2005P-1040AR	30684355
10,50	12	118	71	56	45	M2005P-1050AR	30684356
10,70	12	118	71	56	45	M2005P-1070AR	30684359
10,75	12	118	71	56	45	M2005P-1075AR	30684360
10,80	12	118	71	56	45	M2005P-1080AR	30684361
11,00	12	118	71	56	45	M2005P-1100AR	30684363
11,20	12	118	71	56	45	M2005P-1120AR	30684365
11,25	12	118	71	56	45	M2005P-1125AR	30684366
11,30	12	118	71	56	45	M2005P-1130AR	30684367

**MEGA-Drill-Steel-Plus | Vollhartmetall-Spiralbohrer M2005P (5xD), äußere Kühlmittelzufuhr**

Baumaße						Schaftform HA	
d <sub>1</sub> m7	d <sub>2</sub> h6	l <sub>1</sub>	l <sub>2</sub>	l <sub>3</sub>	l <sub>4</sub>	Spezifikation	Bestell-Nr.
11,35	12	118	71	56	45	M2005P-1135AR	30684368
11,50	12	118	71	56	45	M2005P-1150AR	30684371
11,80	12	118	71	56	45	M2005P-1180AR	30684374
11,90	12	118	71	56	45	M2005P-1190AR	30684375
12,00	12	118	71	56	45	M2005P-1200AR	30684376
12,15	14	124	77	60	45	M2005P-1215AR	30684377
12,25	14	124	77	60	45	M2005P-1225AR	30684378
12,50	14	124	77	60	45	M2005P-1250AR	30684379
12,70	14	124	77	60	45	M2005P-1270AR	30684381
12,80	14	124	77	60	45	M2005P-1280AR	30684382
12,90	14	124	77	60	45	M2005P-1290AR	30684383
13,00	14	124	77	60	45	M2005P-1300AR	30684384
13,10	14	124	77	60	45	M2005P-1310AR	30684385
13,30	14	124	77	60	45	M2005P-1330AR	30684386
13,35	14	124	77	60	45	M2005P-1335AR	30684387
13,50	14	124	77	60	45	M2005P-1350AR	30684388
13,80	14	124	77	60	45	M2005P-1380AR	30684390
14,00	14	124	77	60	45	M2005P-1400AR	30684391
14,20	16	133	83	63	48	M2005P-1420AR	30684392
14,50	16	133	83	63	48	M2005P-1450AR	30684393
14,80	16	133	83	63	48	M2005P-1480AR	30684394
15,00	16	133	83	63	48	M2005P-1500AR	30684395
15,10	16	133	83	63	48	M2005P-1510AR	30684396
15,25	16	133	83	63	48	M2005P-1525AR	30684397
15,30	16	133	83	63	48	M2005P-1530AR	30684398
15,50	16	133	83	63	48	M2005P-1550AR	30684400
15,80	16	133	83	63	48	M2005P-1580AR	30684402
16,00	16	133	83	63	48	M2005P-1600AR	30684403
16,50	18	143	93	71	48	M2005P-1650AR	30684405
16,80	18	143	93	71	48	M2005P-1680AR	30684406
17,00	18	143	93	71	48	M2005P-1700AR	30684408
17,50	18	143	93	71	48	M2005P-1750AR	30684409
17,60	18	143	93	71	48	M2005P-1760AR	30684410
18,00	18	143	93	71	48	M2005P-1800AR	30684412
18,50	20	153	101	77	50	M2005P-1850AR	30684413
18,80	20	153	101	77	50	M2005P-1880AR	30684414
18,90	20	153	101	77	50	M2005P-1890AR	30684415
19,00	20	153	101	77	50	M2005P-1900AR	30684416
19,50	20	153	101	77	50	M2005P-1950AR	30684418
19,80	20	153	101	77	50	M2005P-1980AR	30684420
20,00	20	153	101	77	50	M2005P-2000AR	30684421

Fortsetzung auf nächster Seite.

## MEGA-Drill-Steel-Plus | Vollhartmetall-Spiralbohrer M2005P (5xD), äußere Kühlmittelzufuhr

## Konfigurierbare Merkmale

**Durchmesser:**

Durchmesser in Abstufungen  
von 0,01 mm frei wählbar

**Schaftform:**

Schaftform: HB | HE

**Spezifikation:**

M2005P-[Durchmesser][Schaftform]R

## Abmessungen konfigurierbare Baureihe

d <sub>1</sub> min.	d <sub>1</sub> max.	d <sub>2</sub> h6	l <sub>1</sub>	l <sub>2</sub>	l <sub>3</sub>	l <sub>4</sub>
3,00	3,70	6	66	28	23	36
3,71	4,70	6	74	36	29	36
4,71	6,00	6	82	44	35	36
6,01	8,00	8	91	53	43	36
8,01	10,00	10	103	61	49	40
10,01	12,00	12	118	71	56	45
12,01	14,00	14	124	77	60	45
14,01	16,00	16	133	83	63	48
16,01	18,00	18	143	93	71	48
18,01	20,00	20	153	101	77	50

**Beispiel:**

M2005P-0431ER

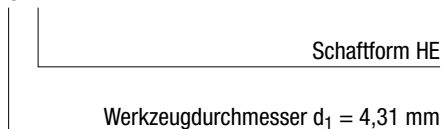

# MEGA-Drill-Steel-Plus

Vollhartmetall-Spiralbohrer

M2105P (5xD), innere Kühlmittelzufuhr, Nachfolgeprodukt des MEGA-Drill-Steel (M2105)

**Ausführung:**

Bohrerdurchmesser: 3,00 - 25,00 mm  
 Bohrungstoleranz:  $\geq$  IT 9  
 Beschichtung: MxP  
 Schneidanzahl: 2  
 Anzahl Führungsfasen: 2  
 Spitzenwinkel: 140°  
 Spiralwinkel: 30°

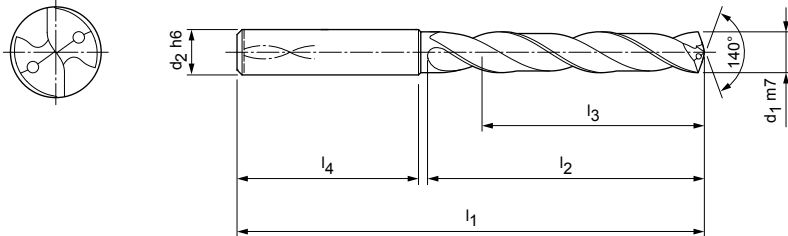

**Lagerhaltige Vorzugsbaureihe in Schaftform HA**

Baumaße						Schaftform HA	
d <sub>1</sub> m7	d <sub>2</sub> h6	l <sub>1</sub>	l <sub>2</sub>	l <sub>3</sub>	l <sub>4</sub>	Spezifikation	Bestell-Nr.
3,00	6	66	28	23	36	M2105P-0300AR	30682857
3,10	6	66	28	23	36	M2105P-0310AR	30682858
3,15	6	66	28	23	36	M2105P-0315AR	30682859
3,20	6	66	28	23	36	M2105P-0320AR	30682860
3,25	6	66	28	23	36	M2105P-0325AR	30682862
3,30	6	66	28	23	36	M2105P-0330AR	30682863
3,40	6	66	28	23	36	M2105P-0340AR	30682864
3,50	6	66	28	23	36	M2105P-0350AR	30682865
3,60	6	66	28	23	36	M2105P-0360AR	30682866
3,65	6	66	28	23	36	M2105P-0365AR	31243327
3,70*	6	66	28	23	36	M2105P-0370AR	30682867
3,80	6	74	36	29	36	M2105P-0380AR	30682868
3,85	6	74	36	29	36	M2105P-0385AR	30682869
3,90	6	74	36	29	36	M2105P-0390AR	30682870
4,00	6	74	36	29	36	M2105P-0400AR	30682871
4,10	6	74	36	29	36	M2105P-0410AR	30682872
4,20	6	74	36	29	36	M2105P-0420AR	30682873
4,25	6	74	36	29	36	M2105P-0425AR	30682874
4,30	6	74	36	29	36	M2105P-0430AR	30682875
4,35	6	74	36	29	36	M2105P-0435AR	30682876
4,40	6	74	36	29	36	M2105P-0440AR	30682877
4,45	6	74	36	29	36	M2105P-0445AR	30682878
4,50	6	74	36	29	36	M2105P-0450AR	30682879
4,60	6	74	36	29	36	M2105P-0460AR	30682880
4,65*	6	74	36	29	36	M2105P-0465AR	30682881
4,70	6	74	36	29	36	M2105P-0470AR	30682882
4,80	6	82	44	35	36	M2105P-0480AR	30682883
4,90	6	82	44	35	36	M2105P-0490AR	30682884
4,95	6	82	44	35	36	M2105P-0495AR	30682885
5,00	6	82	44	35	36	M2105P-0500AR	30682886
5,05	6	82	44	35	36	M2105P-0505AR	30682887
5,10	6	82	44	35	36	M2105P-0510AR	30682888
5,20	6	82	44	35	36	M2105P-0520AR	30682889
5,30	6	82	44	35	36	M2105P-0530AR	30682890
5,40	6	82	44	35	36	M2105P-0540AR	30682891

## MEGA-Drill-Steel-Plus | Vollhartmetall-Spiralbohrer M2105P (5xD), innere Kühlmittelzufuhr

Baumaße						Schaftform HA	
d <sub>1</sub> m7	d <sub>2</sub> h6	l <sub>1</sub>	l <sub>2</sub>	l <sub>3</sub>	l <sub>4</sub>	Spezifikation	Bestell-Nr.
5,50	6	82	44	35	36	M2105P-0550AR	30682892
5,55*	6	82	44	35	36	M2105P-0555AR	30682893
5,60	6	82	44	35	36	M2105P-0560AR	30682894
5,70	6	82	44	35	36	M2105P-0570AR	30682895
5,75	6	82	44	35	36	M2105P-0575AR	30682896
5,80	6	82	44	35	36	M2105P-0580AR	30682897
5,90	6	82	44	35	36	M2105P-0590AR	30682898
5,95	6	82	44	35	36	M2105P-0595AR	30682899
6,00	6	82	44	35	36	M2105P-0600AR	30682900
6,10	8	91	53	43	36	M2105P-0610AR	30682901
6,20	8	91	53	43	36	M2105P-0620AR	30682902
6,30	8	91	53	43	36	M2105P-0630AR	30682903
6,40	8	91	53	43	36	M2105P-0640AR	30682904
6,50	8	91	53	43	36	M2105P-0650AR	30682905
6,60	8	91	53	43	36	M2105P-0660AR	30682906
6,70	8	91	53	43	36	M2105P-0670AR	30682907
6,80	8	91	53	43	36	M2105P-0680AR	30682908
6,90	8	91	53	43	36	M2105P-0690AR	30682909
7,00	8	91	53	43	36	M2105P-0700AR	30682910
7,10	8	91	53	43	36	M2105P-0710AR	30682911
7,20	8	91	53	43	36	M2105P-0720AR	30682912
7,30	8	91	53	43	36	M2105P-0730AR	30682913
7,40	8	91	53	43	36	M2105P-0740AR	30682914
7,45*	8	91	53	43	36	M2105P-0745AR	30682915
7,50	8	91	53	43	36	M2105P-0750AR	30682916
7,60	8	91	53	43	36	M2105P-0760AR	30682917
7,70	8	91	53	43	36	M2105P-0770AR	30682918
7,80	8	91	53	43	36	M2105P-0780AR	30682919
7,90	8	91	53	43	36	M2105P-0790AR	30682920
8,00	8	91	53	43	36	M2105P-0800AR	30682921
8,10	10	103	61	49	40	M2105P-0810AR	30682922
8,20	10	103	61	49	40	M2105P-0820AR	30682923
8,30	10	103	61	49	40	M2105P-0830AR	30682924
8,40	10	103	61	49	40	M2105P-0840AR	30682925
8,50	10	103	61	49	40	M2105P-0850AR	30682926
8,60	10	103	61	49	40	M2105P-0860AR	30682927
8,70	10	103	61	49	40	M2105P-0870AR	30682928
8,80	10	103	61	49	40	M2105P-0880AR	30682929
8,90	10	103	61	49	40	M2105P-0890AR	30682930
9,00	10	103	61	49	40	M2105P-0900AR	30682931
9,10	10	103	61	49	40	M2105P-0910AR	30682932
9,20	10	103	61	49	40	M2105P-0920AR	30682933
9,30*	10	103	61	49	40	M2105P-0930AR	30682934
9,35	10	103	61	49	40	M2105P-0935AR	30682935
9,40	10	103	61	49	40	M2105P-0940AR	30682936
9,45	10	103	61	49	40	M2105P-0945AR	30682937
9,50	10	103	61	49	40	M2105P-0950AR	30682938
9,60	10	103	61	49	40	M2105P-0960AR	30682939
9,70	10	103	61	49	40	M2105P-0970AR	30682940
9,80	10	103	61	49	40	M2105P-0980AR	30682941
9,90	10	103	61	49	40	M2105P-0990AR	30682942
10,00	10	103	61	49	40	M2105P-1000AR	30682943
10,10	12	118	71	56	45	M2105P-1010AR	30682944
10,20	12	118	71	56	45	M2105P-1020AR	30682945
10,30	12	118	71	56	45	M2105P-1030AR	30682946
10,40	12	118	71	56	45	M2105P-1040AR	30682947
10,50	12	118	71	56	45	M2105P-1050AR	30682948

**MEGA-Drill-Steel-Plus | Vollhartmetall-Spiralbohrer M2105P (5xD), innere Kühlmittelzufuhr**

Baumaße						Schaftform HA	
d <sub>1</sub> m7	d <sub>2</sub> h6	l <sub>1</sub>	l <sub>2</sub>	l <sub>3</sub>	l <sub>4</sub>	Spezifikation	Bestell-Nr.
10,55	12	118	71	56	45	M2105P-1055AR	30682949
10,60	12	118	71	56	45	M2105P-1060AR	30682950
10,70	12	118	71	56	45	M2105P-1070AR	30682951
10,80	12	118	71	56	45	M2105P-1080AR	30682953
10,90	12	118	71	56	45	M2105P-1090AR	30682954
11,00	12	118	71	56	45	M2105P-1100AR	30682955
11,10	12	118	71	56	45	M2105P-1110AR	30682956
11,20*	12	118	71	56	45	M2105P-1120AR	30682957
11,25	12	118	71	56	45	M2105P-1125AR	30682958
11,30	12	118	71	56	45	M2105P-1130AR	30682959
11,40	12	118	71	56	45	M2105P-1140AR	30682962
11,50	12	118	71	56	45	M2105P-1150AR	30682964
11,60	12	118	71	56	45	M2105P-1160AR	30682965
11,70	12	118	71	56	45	M2105P-1170AR	30682966
11,80	12	118	71	56	45	M2105P-1180AR	30682967
11,90	12	118	71	56	45	M2105P-1190AR	30682968
12,00	12	118	71	56	45	M2105P-1200AR	30682969
12,15	14	124	77	60	45	M2105P-1215AR	30682970
12,25	14	124	77	60	45	M2105P-1225AR	30682971
12,30	14	124	77	60	45	M2105P-1230AR	31201166
12,50	14	124	77	60	45	M2105P-1250AR	30682972
12,55	14	124	77	60	45	M2105P-1255AR	30682973
12,70	14	124	77	60	45	M2105P-1270AR	30682974
12,80	14	124	77	60	45	M2105P-1280AR	30682975
12,90	14	124	77	60	45	M2105P-1290AR	30682976
13,00	14	124	77	60	45	M2105P-1300AR	30682977
13,10	14	124	77	60	45	M2105P-1310AR	30682978
13,30	14	124	77	60	45	M2105P-1330AR	30682979
13,35	14	124	77	60	45	M2105P-1335AR	30682980
13,50	14	124	77	60	45	M2105P-1350AR	30682981
13,70	14	124	77	60	45	M2105P-1370AR	30682982
13,80	14	124	77	60	45	M2105P-1380AR	30682983
14,00	14	124	77	60	45	M2105P-1400AR	30682984
14,20	16	133	83	63	48	M2105P-1420AR	30682985
14,50	16	133	83	63	48	M2105P-1450AR	30682986
14,80	16	133	83	63	48	M2105P-1480AR	30682987
15,00	16	133	83	63	48	M2105P-1500AR	30682988
15,10	16	133	83	63	48	M2105P-1510AR	30682989
15,25	16	133	83	63	48	M2105P-1525AR	30682990
15,30	16	133	83	63	48	M2105P-1530AR	30682991
15,35	16	133	83	63	48	M2105P-1535AR	30682992
15,50	16	133	83	63	48	M2105P-1550AR	30682993
15,60	16	133	83	63	48	M2105P-1560AR	30682994
15,80	16	133	83	63	48	M2105P-1580AR	30682995
16,00	16	133	83	63	48	M2105P-1600AR	30682996
16,05	18	143	93	71	48	M2105P-1605AR	30682997
16,50	18	143	93	71	48	M2105P-1650AR	30682998
16,80	18	143	93	71	48	M2105P-1680AR	30682999
16,90	18	143	93	71	48	M2105P-1690AR	30683000
17,00	18	143	93	71	48	M2105P-1700AR	30683001

Fortsetzung auf nächster Seite.

## MEGA-Drill-Steel-Plus | Vollhartmetall-Spiralbohrer M2105P (5xD), innere Kühlmittelzufuhr

## Konfigurierbare Merkmale



**Durchmesser:**  
Durchmesser in Abstufungen  
von 0,01 mm frei wählbar



**Schaftform:**  
Schaftform: HB | HE

**Spezifikation:**

M2105P-[Durchmesser][Schaftform]R

**Beispiel:**

M2105P-0431ER

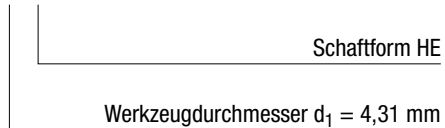

## Abmessungen konfigurierbare Baureihe

d <sub>1</sub> min.	d <sub>1</sub> max.	d <sub>2</sub> h6	l <sub>1</sub>	l <sub>2</sub>	l <sub>3</sub>	l <sub>4</sub>
3,00	3,70	6	66	28	23	36
3,71	4,70	6	74	36	29	36
4,71	6,00	6	82	44	35	36
6,01	8,00	8	91	53	43	36
8,01	10,00	10	103	61	49	40
10,01	12,00	12	118	71	56	45
12,01	14,00	14	124	77	60	45
14,01	16,00	16	133	83	63	48
16,01	18,00	18	143	93	71	48
18,01	20,00	20	153	101	77	50
20,01	22,00	25	200	135	110	56
22,01	25,00	25	200	140	120	56

Maßangaben in mm.

\* Speziell zur Vorfertigung der Kernlöcher für Gewindeformer geeignet.

Schnittwertempfehlung siehe Kapitelende.

Sonderausführungen und andere Beschichtungen auf Anfrage.



# MEGA-Drill-Steel-Plus

Vollhartmetall-Spiralbohrer

M2108P (8xD), innere Kühlmittelzufuhr, Nachfolgeprodukt des MEGA-Drill-Steel (M2108)

**Ausführung:**

Bohrerdurchmesser: 3,00 - 20,00 mm  
 Bohrungstoleranz:  $\geq$  IT 9  
 Beschichtung: MxP  
 Schneidanzahl: 2  
 Anzahl Führungsfasen: 2  
 Spitzenwinkel: 135°  
 Spiralwinkel: 30°

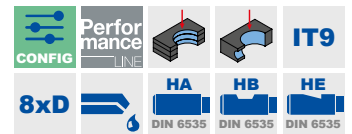
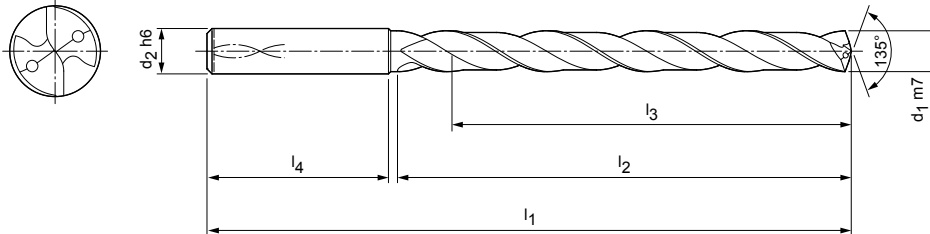

**Lagerhaltige Vorzugsbaureihe in Schaftform HA**

Baumaße						Schaftform HA	
d <sub>1</sub> m7	d <sub>2</sub> h6	l <sub>1</sub>	l <sub>2</sub>	l <sub>3</sub>	l <sub>4</sub>	Spezifikation	Bestell-Nr.
3,00	6	72	34	29	36	M2108P-0300AR	30683363
3,10	6	72	34	29	36	M2108P-0310AR	30683364
3,20	6	72	34	29	36	M2108P-0320AR	30683365
3,30	6	72	34	29	36	M2108P-0330AR	30683366
3,40	6	72	34	29	36	M2108P-0340AR	30683367
3,50	6	72	34	29	36	M2108P-0350AR	30683368
3,60	6	72	34	29	36	M2108P-0360AR	30683369
3,70	6	72	34	29	36	M2108P-0370AR	30683371
3,80	6	81	43	36	36	M2108P-0380AR	30683372
3,90	6	81	43	36	36	M2108P-0390AR	30683373
4,00	6	81	43	36	36	M2108P-0400AR	30683374
4,10	6	81	43	36	36	M2108P-0410AR	30683376
4,20	6	81	43	36	36	M2108P-0420AR	30683377
4,30	6	81	43	36	36	M2108P-0430AR	30683378
4,40	6	81	43	36	36	M2108P-0440AR	30683379
4,50	6	81	43	36	36	M2108P-0450AR	30683380
4,60	6	81	43	36	36	M2108P-0460AR	30683381
4,70	6	81	43	36	36	M2108P-0470AR	30683382
4,80	6	95	57	48	36	M2108P-0480AR	30683383
4,90	6	95	57	48	36	M2108P-0490AR	30683384
5,00	6	95	57	48	36	M2108P-0500AR	30683385
5,10	6	95	57	48	36	M2108P-0510AR	30683386
5,20	6	95	57	48	36	M2108P-0520AR	30683387
5,30	6	95	57	48	36	M2108P-0530AR	30683388
5,40	6	95	57	48	36	M2108P-0540AR	30683389
5,50	6	95	57	48	36	M2108P-0550AR	30683390
5,60	6	95	57	48	36	M2108P-0560AR	30683391
5,70	6	95	57	48	36	M2108P-0570AR	30683392
5,80	6	95	57	48	36	M2108P-0580AR	30683393
5,90	6	95	57	48	36	M2108P-0590AR	30683394
6,00	6	95	57	48	36	M2108P-0600AR	30683395
6,10	8	114	76	64	36	M2108P-0610AR	30683396
6,20	8	114	76	64	36	M2108P-0620AR	30683397
6,30	8	114	76	64	36	M2108P-0630AR	30683398
6,40	8	114	76	64	36	M2108P-0640AR	30683399

## MEGA-Drill-Steel-Plus | Vollhartmetall-Spiralbohrer M2108P (8xD), innere Kühlmittelzufuhr

Baumaße						Schaftform HA	
d <sub>1</sub> m7	d <sub>2</sub> h6	l <sub>1</sub>	l <sub>2</sub>	l <sub>3</sub>	l <sub>4</sub>	Spezifikation	Bestell-Nr.
6,50	8	114	76	64	36	M2108P-0650AR	30683400
6,60	8	114	76	64	36	M2108P-0660AR	30683401
6,70	8	114	76	64	36	M2108P-0670AR	30683402
6,80	8	114	76	64	36	M2108P-0680AR	30683403
6,90	8	114	76	64	36	M2108P-0690AR	30683404
7,00	8	114	76	64	36	M2108P-0700AR	30683405
7,10	8	114	76	64	36	M2108P-0710AR	30683406
7,20	8	114	76	64	36	M2108P-0720AR	30683407
7,30	8	114	76	64	36	M2108P-0730AR	30683408
7,40	8	114	76	64	36	M2108P-0740AR	30683409
7,50	8	114	76	64	36	M2108P-0750AR	30683410
7,60	8	114	76	64	36	M2108P-0760AR	30683411
7,70	8	114	76	64	36	M2108P-0770AR	30683412
7,80	8	114	76	64	36	M2108P-0780AR	30683413
7,90	8	114	76	64	36	M2108P-0790AR	30683414
8,00	8	114	76	64	36	M2108P-0800AR	30683415
8,10	10	142	95	80	40	M2108P-0810AR	30683416
8,20	10	142	95	80	40	M2108P-0820AR	30683417
8,40	10	142	95	80	40	M2108P-0840AR	30683419
8,50	10	142	95	80	40	M2108P-0850AR	30683420
8,60	10	142	95	80	40	M2108P-0860AR	30683421
8,70	10	142	95	80	40	M2108P-0870AR	30683422
8,80	10	142	95	80	40	M2108P-0880AR	30683424
8,90	10	142	95	80	40	M2108P-0890AR	30683425
9,00	10	142	95	80	40	M2108P-0900AR	30683426
9,10	10	142	95	80	40	M2108P-0910AR	30683427
9,20	10	142	95	80	40	M2108P-0920AR	30683428
9,30	10	142	95	80	40	M2108P-0930AR	30683429
9,40	10	142	95	80	40	M2108P-0940AR	30683430
9,50	10	142	95	80	40	M2108P-0950AR	30683431
9,60	10	142	95	80	40	M2108P-0960AR	30683432
9,80	10	142	95	80	40	M2108P-0980AR	30683434
9,90	10	142	95	80	40	M2108P-0990AR	30683435
10,00	10	142	95	80	40	M2108P-1000AR	30683436
10,10	12	162	114	96	45	M2108P-1010AR	30683437
10,20	12	162	114	96	45	M2108P-1020AR	30683438
10,30	12	162	114	95	45	M2108P-1030AR	30683439
10,40	12	162	114	96	45	M2108P-1040AR	30683440
10,50	12	162	114	96	45	M2108P-1050AR	30683441
10,70	12	162	114	96	45	M2108P-1070AR	30683443
10,80	12	162	114	96	45	M2108P-1080AR	30683444
11,00	12	162	114	96	45	M2108P-1100AR	30683446
11,10	12	162	114	96	45	M2108P-1110AR	30683447
11,20	12	162	114	96	45	M2108P-1120AR	30683449
11,30	12	162	114	96	45	M2108P-1130AR	30683450
11,40	12	162	114	96	45	M2108P-1140AR	30683451
11,50	12	162	114	96	45	M2108P-1150AR	30683452
11,80	12	162	114	96	45	M2108P-1180AR	30683455
12,00	12	162	114	96	45	M2108P-1200AR	30683457
12,50	14	178	133	112	45	M2108P-1250AR	30683458
12,80	14	178	133	112	45	M2108P-1280AR	30683459
13,00	14	178	133	112	45	M2108P-1300AR	30683460
13,50	14	178	133	112	45	M2108P-1350AR	30683461
13,80	14	178	133	112	45	M2108P-1380AR	30683462
14,00	14	178	133	112	45	M2108P-1400AR	30683463
14,50	16	203	152	128	48	M2108P-1450AR	30683464
14,80	16	203	152	128	48	M2108P-1480AR	30683465

## MEGA-Drill-Steel-Plus | Vollhartmetall-Spiralbohrer M2108P (8xD), innere Kühlmittelzufuhr

Baumaße						Schaftform HA	
d <sub>1</sub> m7	d <sub>2</sub> h6	l <sub>1</sub>	l <sub>2</sub>	l <sub>3</sub>	l <sub>4</sub>	Spezifikation	Bestell-Nr.
15,00	16	203	152	128	48	M2108P-1500AR	30683466
15,50	16	203	152	128	48	M2108P-1550AR	30683467
15,80	16	203	152	128	48	M2108P-1580AR	30683468
16,00	16	203	152	128	48	M2108P-1600AR	30683469
17,00	18	222	171	144	48	M2108P-1700AR	30683472
17,50	18	222	171	144	48	M2108P-1750AR	30683473
17,80	18	222	171	144	48	M2108P-1780AR	30683474
18,00	18	222	171	144	48	M2108P-1800AR	30683475
18,50	20	243	190	160	50	M2108P-1850AR	30683476
18,80	20	243	190	160	50	M2108P-1880AR	30683477
19,50	20	243	190	160	50	M2108P-1950AR	30683480
19,80	20	243	190	160	50	M2108P-1980AR	30683481
20,00	20	243	190	160	50	M2108P-2000AR	30683482

## Konfigurierbare Merkmale



**Durchmesser:**  
Durchmesser in Abstufungen  
von 0,01 mm frei wählbar



**Schaftform:**  
Schaftform: HB | HE

**Spezifikation:**

M2108P-[Durchmesser][Schaftform]R

## Abmessungen konfigurierbare Baureihe

d <sub>1</sub> min.	d <sub>1</sub> max.	d <sub>2</sub> h6	l <sub>1</sub>	l <sub>2</sub>	l <sub>3</sub>	l <sub>4</sub>
3,00	3,70	6	72	34	29	36
3,71	4,70	6	81	43	36	36
4,71	6,00	6	95	57	48	36
6,01	8,00	8	114	76	64	36
8,01	10,00	10	142	95	80	40
10,01	12,00	12	162	114	96	45
12,01	14,00	14	178	133	112	45
14,01	16,00	16	203	152	128	48
16,01	18,00	18	222	171	144	48
18,01	20,00	20	243	190	160	50

**Beispiel:**  
M2108P-0431ER

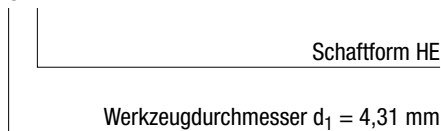

Maßangaben in mm.

Schnittwertempfehlung siehe Kapitelende.

Sonderausführungen und andere Beschichtungen auf Anfrage.

# MEGA-Quadro-Drill-Plus

Vollhartmetall-Spiralbohrer

M2075P (5xD), äußere Kühlmittelzufuhr, Nachfolgeprodukt des MEGA-Quadro-Drill (M2075)

## Ausführung:

Bohrerdurchmesser:	3,00 - 20,00 mm
Bohrungstoleranz:	≥ IT 8
Beschichtung:	MxP
Schneidenanzahl:	2
Anzahl Führungsfasen:	4
Spitzenwinkel:	140°
Spiralwinkel:	30°

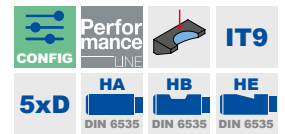
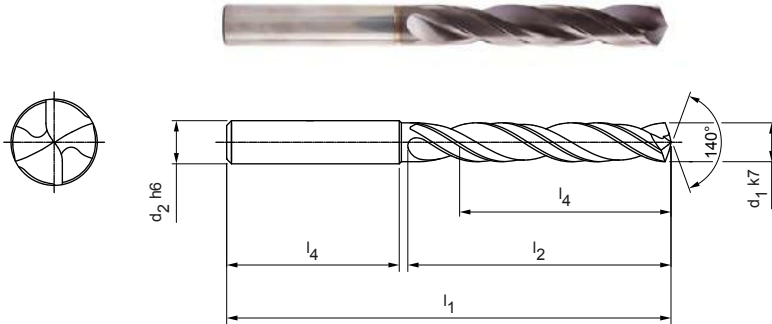

## Lagerhaltige Vorzugsbaureihe in Schaftform HA

Baumaße						Schaftform HA	
d <sub>1</sub> k7	d <sub>2</sub> h6	l <sub>1</sub>	l <sub>2</sub>	l <sub>3</sub>	l <sub>4</sub>	Spezifikation	Bestell-Nr.
3,00	6	66	28	23	36	M2075P-0300AR	31011581
3,10	6	66	28	23	36	M2075P-0310AR	31011582
3,20	6	66	28	23	36	M2075P-0320AR	31011584
3,30	6	66	28	23	36	M2075P-0330AR	31011585
3,40	6	66	28	23	36	M2075P-0340AR	31011586
3,50	6	66	28	23	36	M2075P-0350AR	31011587
3,70	6	66	28	23	36	M2075P-0370AR	31011589
4,00	6	74	36	29	36	M2075P-0400AR	31011592
4,20	6	74	36	29	36	M2075P-0420AR	31011594
4,30	6	74	36	29	36	M2075P-0430AR	31011595
4,50	6	74	36	29	36	M2075P-0450AR	31011597
4,80	6	82	44	35	36	M2075P-0480AR	31011600
5,00	6	82	44	35	36	M2075P-0500AR	31011602
5,10	6	82	44	35	36	M2075P-0510AR	31011603
5,20	6	82	44	35	36	M2075P-0520AR	31011604
5,50	6	82	44	35	36	M2075P-0550AR	31011607
5,60	6	82	44	35	36	M2075P-0560AR	31011608
5,80	6	82	44	35	36	M2075P-0580AR	31011610
6,00	6	82	44	35	36	M2075P-0600AR	31011612
6,40	8	91	53	43	36	M2075P-0640AR	31011616
6,50	8	91	53	43	36	M2075P-0650AR	31011617
6,80	8	91	53	43	36	M2075P-0680AR	31011620
6,90	8	91	53	43	36	M2075P-0690AR	31011621
7,00	8	91	53	43	36	M2075P-0700AR	31011622
7,40	8	91	53	43	36	M2075P-0740AR	31011626
7,50	8	91	53	43	36	M2075P-0750AR	31011627
7,80	8	91	53	43	36	M2075P-0780AR	31011630
8,00	8	91	53	43	36	M2075P-0800AR	31011632
8,50	10	103	61	49	40	M2075P-0850AR	31011637
8,60	10	103	61	49	40	M2075P-0860AR	31011638
8,80	10	103	61	49	40	M2075P-0880AR	31011640
9,00	10	103	61	49	40	M2075P-0900AR	31011642
9,50	10	103	61	49	40	M2075P-0950AR	31011647
9,80	10	103	61	49	40	M2075P-0980AR	31011650
10,00	10	103	61	49	40	M2075P-1000AR	31011652

## MEGA-Quadro-Drill-Plus | Vollhartmetall-Spiralbohrer M2075P (5xD), äußere Kühlmittelzufuhr

Baumaße						Schaftform HA	
d <sub>1</sub> k7	d <sub>2</sub> h6	l <sub>1</sub>	l <sub>2</sub>	l <sub>3</sub>	l <sub>4</sub>	Spezifikation	Bestell-Nr.
10,20	12	118	71	56	45	M2075P-1020AR	31011654
10,30	12	118	71	56	45	M2075P-1030AR	31011655
10,50	12	118	71	56	45	M2075P-1050AR	31011657
10,90	12	118	71	56	45	M2075P-1090AR	31011661
11,00	12	118	71	56	45	M2075P-1100AR	31011662
11,50	12	118	71	56	45	M2075P-1150AR	31011667
11,80	12	118	71	56	45	M2075P-1180AR	31011670
12,00	12	118	71	56	45	M2075P-1200AR	31011672
12,50	14	124	77	60	45	M2075P-1250AR	31011673
13,00	14	124	77	60	45	M2075P-1300AR	31011675
13,50	14	124	77	60	45	M2075P-1350AR	31011676
14,00	14	124	77	60	45	M2075P-1400AR	31011678
14,50	16	133	83	63	48	M2075P-1450AR	31011679
15,00	16	133	83	63	48	M2075P-1500AR	31011681
16,00	16	133	83	63	48	M2075P-1600AR	31011684
17,00	18	143	93	71	48	M2075P-1700AR	31011687
17,50	18	143	93	71	48	M2075P-1750AR	31011688
18,00	18	143	93	71	48	M2075P-1800AR	31011690
18,50	20	153	101	77	50	M2075P-1850AR	31011691
20,00	20	153	101	77	50	M2075P-2000AR	31011696

## Konfigurierbare Merkmale

**Durchmesser:**

Durchmesser in Abstufungen  
von 0,01 mm frei wählbar

**Schaftform:**

Schaftform: HB | HE

**Spezifikation:**

M2075P-[Durchmesser][Schaftform]R

## Abmessungen konfigurierbare Baureihe

d <sub>1</sub> min.	d <sub>1</sub> max.	d <sub>2</sub> h6	l <sub>1</sub>	l <sub>2</sub>	l <sub>3</sub>	l <sub>4</sub>
3,00	3,70	6	66	28	23	36
3,71	4,70	6	74	36	29	36
4,71	6,00	6	82	44	35	36
6,01	8,00	8	91	53	43	36
8,01	10,00	10	103	61	49	40
10,01	12,00	12	118	71	56	45
12,01	14,00	14	124	77	60	45
14,01	16,00	16	133	83	63	48
16,01	18,00	18	143	93	71	48
18,01	20,00	20	153	101	77	50

**Beispiel:**  
M2075P-0431ER

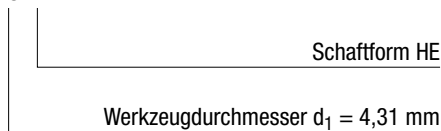

Maßangaben in mm.

Schnittwertempfehlung siehe Kapitelende.

Sonderausführungen und andere Beschichtungen auf Anfrage.

# MEGA-Quadro-Drill-Plus

Vollhartmetall-Spiralbohrer

M2175P (5xD), innere Kühlmittelzufuhr, Nachfolgeprodukt des MEGA-Quadro-Drill (M2175)

## Ausführung:

Bohrerdurchmesser:	3,00 - 20,00 mm
Bohrungstoleranz:	≥ IT 8
Beschichtung:	MxP
Schneidenanzahl:	2
Anzahl Führungsfasen:	4
Spitzenwinkel:	140°
Spiralwinkel:	30°

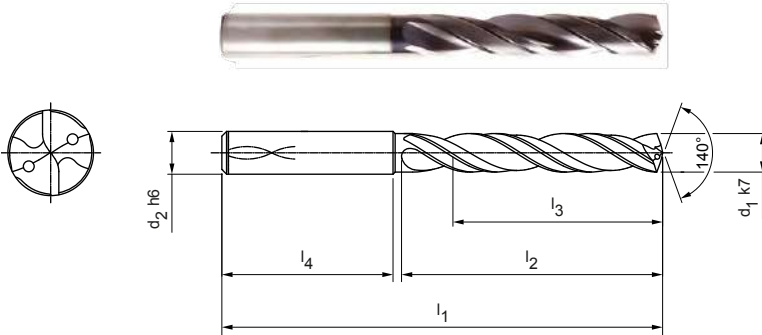

## Lagerhaltige Vorzugsbaureihe in Schaftform HA

Baumaße						Schaftform HA	
d <sub>1</sub> k7	d <sub>2</sub> h6	l <sub>1</sub>	l <sub>2</sub>	l <sub>3</sub>	l <sub>4</sub>	Spezifikation	Bestell-Nr.
3,00	6	66	28	23	36	M2175P-0300AR	31006454
3,10	6	66	28	23	36	M2175P-0310AR	31006455
3,20	6	66	28	23	36	M2175P-0320AR	31006456
3,30	6	66	28	23	36	M2175P-0330AR	31006457
3,40	6	66	28	23	36	M2175P-0340AR	31006458
3,50	6	66	28	23	36	M2175P-0350AR	31006459
3,70	6	66	28	23	36	M2175P-0370AR	31006461
3,80	6	74	36	29	36	M2175P-0380AR	31006462
3,90	6	74	36	29	36	M2175P-0390AR	31006463
4,00	6	74	36	29	36	M2175P-0400AR	31006464
4,20	6	74	36	29	36	M2175P-0420AR	31006466
4,30	6	74	36	29	36	M2175P-0430AR	31006467
4,50	6	74	36	29	36	M2175P-0450AR	31006469
4,80	6	82	44	35	36	M2175P-0480AR	31006472
5,00	6	82	44	35	36	M2175P-0500AR	31006474
5,10	6	82	44	35	36	M2175P-0510AR	31006475
5,20	6	82	44	35	36	M2175P-0520AR	31006476
5,30	6	82	44	35	36	M2175P-0530AR	31006477
5,50	6	82	44	35	36	M2175P-0550AR	31006479
5,60	6	82	44	35	36	M2175P-0560AR	31006480
5,80	6	82	44	35	36	M2175P-0580AR	31006482
5,90	6	82	44	35	36	M2175P-0590AR	31006483
6,00	6	82	44	35	36	M2175P-0600AR	31006484
6,40	8	91	53	43	36	M2175P-0640AR	31006488
6,50	8	91	53	43	36	M2175P-0650AR	31006489
6,60	8	91	53	43	36	M2175P-0660AR	31006490
6,70	8	91	53	43	36	M2175P-0670AR	31006491
6,80	8	91	53	43	36	M2175P-0680AR	31006492
6,90	8	91	53	43	36	M2175P-0690AR	31006493
7,00	8	91	53	43	36	M2175P-0700AR	31006494
7,20	8	91	53	43	36	M2175P-0720AR	31006496
7,40	8	91	53	43	36	M2175P-0740AR	31006498
7,50	8	91	53	43	36	M2175P-0750AR	31006499
7,80	8	91	53	43	36	M2175P-0780AR	31006502
7,90	8	91	53	43	36	M2175P-0790AR	31006503

## MEGA-Quadro-Drill-Plus | Vollhartmetall-Spiralbohrer M2175P (5xD), innere Kühlmittelzufuhr

Baumaße						Schaffform HA	
d <sub>1</sub> k7	d <sub>2</sub> h6	l <sub>1</sub>	l <sub>2</sub>	l <sub>3</sub>	l <sub>4</sub>	Spezifikation	Bestell-Nr.
8,00	8	91	53	43	36	M2175P-0800AR	31006504
8,10	10	103	61	49	40	M2175P-0810AR	31006505
8,30	10	103	61	49	40	M2175P-0830AR	31006507
8,40	10	103	61	49	40	M2175P-0840AR	31006508
8,50	10	103	61	49	40	M2175P-0850AR	31006509
8,60	10	103	61	49	40	M2175P-0860AR	31006510
8,80	10	103	61	49	40	M2175P-0880AR	31006512
9,00	10	103	61	49	40	M2175P-0900AR	31006514
9,20	10	103	61	49	40	M2175P-0920AR	31006516
9,30	10	103	61	49	40	M2175P-0930AR	31006517
9,50	10	103	61	49	40	M2175P-0950AR	31006519
9,80	10	103	61	49	40	M2175P-0980AR	31006522
9,90	10	103	61	49	40	M2175P-0990AR	31006523
10,00	10	103	61	49	40	M2175P-1000AR	31006524
10,20	12	118	71	56	45	M2175P-1020AR	31006526
10,30	12	118	71	56	45	M2175P-1030AR	31006527
10,40	12	118	71	56	45	M2175P-1040AR	31006529
10,50	12	118	71	56	45	M2175P-1050AR	31006530
10,90	12	118	71	56	45	M2175P-1090AR	31006534
11,00	12	118	71	56	45	M2175P-1100AR	31006535
11,50	12	118	71	56	45	M2175P-1150AR	31006540
11,70	12	118	71	56	45	M2175P-1170AR	31006542
11,80	12	118	71	56	45	M2175P-1180AR	31006543

## Konfigurierbare Merkmale



**Durchmesser:**  
Durchmesser in Abstufungen  
von 0,01 mm frei wählbar



**Schaftform:**  
Schaftform: HB | HE

**Spezifikation:**

M2175P-[Durchmesser][Schaftform]R

## Abmessungen konfigurierbare Baureihe

d <sub>1</sub> min.	d <sub>1</sub> max.	d <sub>2</sub> h6	l <sub>1</sub>	l <sub>2</sub>	l <sub>3</sub>	l <sub>4</sub>
3,00	3,70	6	66	28	23	36
3,71	4,70	6	74	36	29	36
4,71	6,00	6	82	44	35	36
6,01	8,00	8	91	53	43	36
8,01	10,00	10	103	61	49	40
10,01	12,00	12	118	71	56	45
12,01	14,00	14	124	77	60	45
14,01	16,00	16	133	83	63	48
16,01	18,00	18	143	93	71	48
18,01	20,00	20	153	101	77	50

**Beispiel:**  
M2175P-0431ER

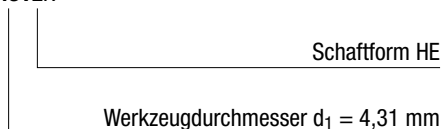

Maßangaben in mm.

Schnittwertempfehlung siehe Kapitelende.

Sonderausführungen und andere Beschichtungen auf Anfrage.

# MEGA-Quadro-Drill-Plus

Vollhartmetall-Spiralbohrer

M2178P (8xD), innere Kühlmittelzufuhr, Nachfolgeprodukt des MEGA-Quadro-Drill (M2178)

## Ausführung:

Bohrerdurchmesser:	3,00 - 20,00 mm
Bohrungstoleranz:	≥ IT 8
Beschichtung:	MxP
Schneidenanzahl:	2
Anzahl Führungsfasen:	4
Spitzenwinkel:	140°
Spiralwinkel:	30°

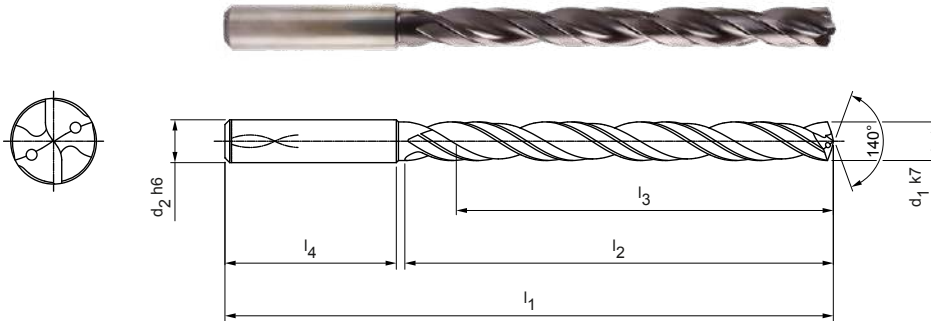

## Lagerhaltige Vorzugsbaureihe in Schaftform HA

Baumaße						Schaftform HA	
d <sub>1</sub> k7	d <sub>2</sub> h6	l <sub>1</sub>	l <sub>2</sub>	l <sub>3</sub>	l <sub>4</sub>	Spezifikation	Bestell-Nr.
3,00	6	72	34	29	36	M2178P-0300AR	31006571
3,10	6	72	34	29	36	M2178P-0310AR	31006572
3,20	6	72	34	29	36	M2178P-0320AR	31006573
3,30	6	72	34	29	36	M2178P-0330AR	31006574
3,40	6	72	34	29	36	M2178P-0340AR	31006575
3,50	6	72	34	29	36	M2178P-0350AR	31006576
3,60	6	72	34	29	36	M2178P-0360AR	31006577
3,70	6	72	34	29	36	M2178P-0370AR	31006578
3,80	6	81	43	36	36	M2178P-0380AR	31006579
3,90	6	81	43	36	36	M2178P-0390AR	31006580
4,00	6	81	43	36	36	M2178P-0400AR	31006581
4,10	6	81	43	36	36	M2178P-0410AR	31006582
4,20	6	81	43	36	36	M2178P-0420AR	31006583
4,30	6	81	43	36	36	M2178P-0430AR	31006584
4,40	6	81	43	36	36	M2178P-0440AR	31006585
4,50	6	81	43	36	36	M2178P-0450AR	31006586
4,60	6	81	43	36	36	M2178P-0460AR	31006587
4,80	6	95	57	48	36	M2178P-0480AR	31006589
4,90	6	95	57	48	36	M2178P-0490AR	31006590
5,00	6	95	57	48	36	M2178P-0500AR	31006591
5,10	6	95	57	48	36	M2178P-0510AR	31006592
5,20	6	95	57	48	36	M2178P-0520AR	31006593
5,40	6	95	57	48	36	M2178P-0540AR	31006595
5,50	6	95	57	48	36	M2178P-0550AR	31006596
5,60	6	95	57	48	36	M2178P-0560AR	31006597
5,70	6	95	57	48	36	M2178P-0570AR	31006598
5,80	6	95	57	48	36	M2178P-0580AR	31006599
6,00	6	95	57	48	36	M2178P-0600AR	31006601
6,10	8	114	76	64	36	M2178P-0610AR	31006602
6,20	8	114	76	64	36	M2178P-0620AR	31006603
6,50	8	114	76	64	36	M2178P-0650AR	31006606
6,60	8	114	76	64	36	M2178P-0660AR	31006608
6,80	8	114	76	64	36	M2178P-0680AR	31006610
6,90	8	114	76	64	36	M2178P-0690AR	31006611
7,00	8	114	76	64	36	M2178P-0700AR	31006612



**MEGA-Quadro-Drill-Plus | Vollhartmetall-Spiralbohrer M2178P (8xD), innere Kühlmittelzufuhr**

Baumaße						Schaftform HA	
d <sub>1</sub> k7	d <sub>2</sub> h6	l <sub>1</sub>	l <sub>2</sub>	l <sub>3</sub>	l <sub>4</sub>	Spezifikation	Bestell-Nr.
7,20	8	114	76	64	36	M2178P-0720AR	31006614
7,40	8	114	76	64	36	M2178P-0740AR	31006616
7,50	8	114	76	64	36	M2178P-0750AR	31006617
7,60	8	114	76	64	36	M2178P-0760AR	31006618
7,80	8	114	76	64	36	M2178P-0780AR	31006620
8,00	8	114	76	64	36	M2178P-0800AR	31006622
8,20	10	142	95	80	40	M2178P-0820AR	31006624
8,50	10	142	95	80	40	M2178P-0850AR	31006627
8,60	10	142	95	80	40	M2178P-0860AR	31006628
8,70	10	142	95	80	40	M2178P-0870AR	31006629
8,90	10	142	95	80	40	M2178P-0890AR	31006631
9,00	10	142	95	80	40	M2178P-0900AR	31006632
9,50	10	142	95	80	40	M2178P-0950AR	31006637
9,60	10	142	95	80	40	M2178P-0960AR	31006638
9,70	10	142	95	80	40	M2178P-0970AR	31006639
9,80	10	142	95	80	40	M2178P-0980AR	31006640
9,90	10	142	95	80	40	M2178P-0990AR	31006641
10,00	10	142	95	80	40	M2178P-1000AR	31006642
10,10	12	162	114	96	45	M2178P-1010AR	31006643
10,20	12	162	114	96	45	M2178P-1020AR	31006644
10,50	12	162	114	96	45	M2178P-1050AR	31006647
10,60	12	162	114	96	45	M2178P-1060AR	31006648
10,70	12	162	114	96	45	M2178P-1070AR	31006649
11,00	12	162	114	96	45	M2178P-1100AR	31006652
11,30	12	162	114	96	45	M2178P-1130AR	31006656
11,70	12	162	114	96	45	M2178P-1170AR	31006660
11,80	12	162	114	96	45	M2178P-1180AR	31006661
12,00	12	162	114	96	45	M2178P-1200AR	31006663
12,50	14	178	133	112	45	M2178P-1250AR	31006664
12,80	14	178	133	112	45	M2178P-1280AR	31006665
13,00	14	178	133	112	45	M2178P-1300AR	31006666
13,50	14	178	133	112	45	M2178P-1350AR	31006667
14,00	14	178	133	112	45	M2178P-1400AR	31006669
15,00	16	203	152	128	48	M2178P-1500AR	31006672
15,80	16	203	152	128	48	M2178P-1580AR	31006674
16,00	16	203	152	128	48	M2178P-1600AR	31006675
16,50	18	222	171	144	48	M2178P-1650AR	31006676
20,00	20	243	190	160	50	M2178P-2000AR	31006687

**Konfigurierbare Merkmale**



**Durchmesser:**  
Durchmesser in Abstufungen von 0,01 mm frei wählbar



**Schaftform:**  
Schaftform: HB | HE

**Spezifikation:**  
M2178P-[Durchmesser][Schaftform]R

**Abmessungen konfigurierbare Baureihe**

d <sub>1</sub> min.	d <sub>1</sub> max.	d <sub>2</sub> h6	l <sub>1</sub>	l <sub>2</sub>	l <sub>3</sub>	l <sub>4</sub>
3,00	3,70	6	72	34	29	36
3,71	4,70	6	81	43	36	36
4,71	6,00	6	95	57	48	36
6,01	8,00	8	114	76	64	36
8,01	10,00	10	142	95	80	40
10,01	12,00	12	162	114	96	45
12,01	14,00	14	178	133	112	45
14,01	16,00	16	203	152	128	48
16,01	18,00	18	222	171	144	48
18,01	20,00	20	243	190	160	50

**Beispiel:**  
M2178P-0431ER

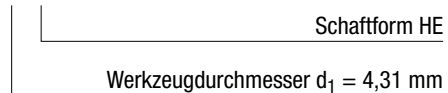

Maßangaben in mm.  
Schnittwertempfehlung siehe Kapitelende.  
Sonderausführungen und andere Beschichtungen auf Anfrage.

# MEGA-Quadro-Drill-Plus

Vollhartmetall-Spiralbohrer

M2182P (12xD), innere Kühlmittelzufuhr, Nachfolgeprodukt des MEGA-Quadro-Drill (M2182)

## Ausführung:

Bohrerdurchmesser:	3,00 - 20,00 mm
Bohrungstoleranz:	≥ IT 8
Beschichtung:	MxP
Schneidenanzahl:	2
Anzahl Führungsfasen:	4
Spitzenwinkel:	140°
Spiralwinkel:	30°

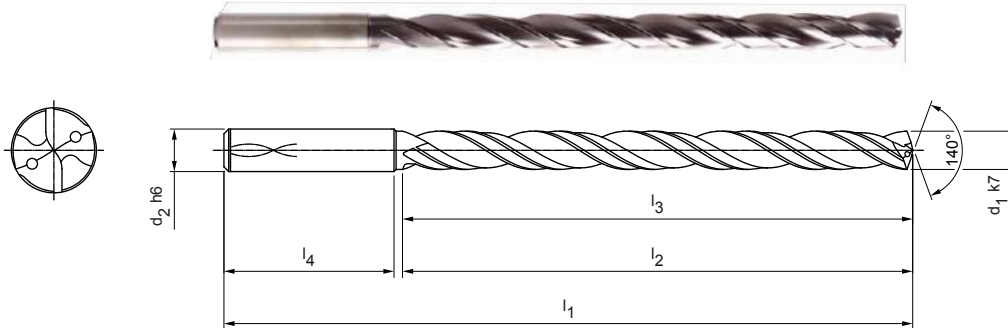

## Lagerhaltige Vorzugsbaureihe in Schaftform HA

Baumaße						Schaftform HA	
d <sub>1</sub> k7	d <sub>2</sub> h6	l <sub>1</sub>	l <sub>2</sub>	l <sub>3</sub>	l <sub>4</sub>	Spezifikation	Bestell-Nr.
3,00	6	92	54	48	36	M2182P-0300AR	31005359
3,10	6	92	54	48	36	M2182P-0310AR	31005360
3,20	6	92	54	48	36	M2182P-0320AR	31005361
3,30	6	92	54	48	36	M2182P-0330AR	31005362
3,40	6	92	54	48	36	M2182P-0340AR	31005363
3,50	6	92	54	48	36	M2182P-0350AR	31005364
3,60	6	92	54	48	36	M2182P-0360AR	31005365
3,70	6	92	54	48	36	M2182P-0370AR	31005366
3,80	6	102	64	58	36	M2182P-0380AR	31005367
3,90	6	102	64	58	36	M2182P-0390AR	31005368
4,00	6	102	64	58	36	M2182P-0400AR	31005369
4,05	6	102	64	58	36	M2182P-0405AR	31125164
4,10	6	102	64	58	36	M2182P-0410AR	31005370
4,20	6	102	64	58	36	M2182P-0420AR	31005371
4,30	6	102	64	58	36	M2182P-0430AR	31005372
4,40	6	102	64	58	36	M2182P-0440AR	31005373
4,50	6	102	64	58	36	M2182P-0450AR	31005374
4,60	6	102	64	58	36	M2182P-0460AR	31005375
4,65	6	116	78	58	36	M2182P-0465AR	31179274
4,70	6	102	64	58	36	M2182P-0470AR	31005376
4,80	6	116	78	70	36	M2182P-0480AR	31005377
5,00	6	116	78	70	36	M2182P-0500AR	31005379
5,05	6	116	78	70	36	M2182P-0505AR	31245036
5,10	6	116	78	70	36	M2182P-0510AR	31005380
5,20	6	116	78	70	36	M2182P-0520AR	31005381
5,40	6	116	78	70	36	M2182P-0540AR	31005383
5,50	6	116	78	70	36	M2182P-0550AR	31005384
5,60	6	116	78	70	36	M2182P-0560AR	31005385
5,70	6	116	78	70	36	M2182P-0570AR	31005386
5,80	6	116	78	70	36	M2182P-0580AR	31005387
6,00	6	116	78	70	36	M2182P-0600AR	31005389
6,10	8	146	108	94	36	M2182P-0610AR	31005390
6,40	8	146	108	94	36	M2182P-0640AR	31005393
6,50	8	146	108	94	36	M2182P-0650AR	31005394
6,80	8	146	108	94	36	M2182P-0680AR	31005397

**MEGA-Quadro-Drill-Plus | Vollhartmetall-Spiralbohrer M2182P (12xD), innere Kühlmittelzufuhr**

Baumaße						Schaftform HA	
d <sub>1</sub> k7	d <sub>2</sub> h6	l <sub>1</sub>	l <sub>2</sub>	l <sub>3</sub>	l <sub>4</sub>	Spezifikation	Bestell-Nr.
6,90	8	146	108	94	36	M2182P-0690AR	31005398
7,00	8	146	108	94	36	M2182P-0700AR	31005399
7,10	8	146	108	94	36	M2182P-0710AR	31005400
7,50	8	146	108	94	36	M2182P-0750AR	31005404
7,60	8	146	108	94	36	M2182P-0760AR	31005405
7,70	8	146	108	94	36	M2182P-0770AR	31005406
7,80	8	146	108	94	36	M2182P-0780AR	31005407
7,90	8	146	108	94	36	M2182P-0790AR	31005408
8,00	8	146	108	94	36	M2182P-0800AR	31005409
8,20	10	162	120	110	40	M2182P-0820AR	31005411
8,30	10	162	120	110	40	M2182P-0830AR	31005412
8,40	10	162	120	110	40	M2182P-0840AR	31005413
8,50	10	162	120	110	40	M2182P-0850AR	31005414
8,60	10	162	120	110	40	M2182P-0860AR	31005415
8,70	10	162	120	110	40	M2182P-0870AR	31005416
9,00	10	162	120	110	40	M2182P-0900AR	31005419
9,50	10	162	120	110	40	M2182P-0950AR	31005424
9,60	10	162	120	110	40	M2182P-0960AR	31005425
9,80	10	162	120	110	40	M2182P-0980AR	31005427
9,90	10	162	120	110	40	M2182P-0990AR	31005428
10,00	10	162	120	110	40	M2182P-1000AR	31005429
10,20	12	204	156	142	45	M2182P-1020AR	31005431
10,50	12	204	156	142	45	M2182P-1050AR	31005434
10,60	12	204	156	142	45	M2182P-1060AR	31005435
11,00	12	204	156	142	45	M2182P-1100AR	31005439
11,20	12	204	156	142	45	M2182P-1120AR	31005441
11,70	12	204	156	142	45	M2182P-1170AR	31005446
11,80	12	204	156	142	45	M2182P-1180AR	31005447
12,00	12	204	156	142	45	M2182P-1200AR	31005449
12,50	14	230	182	166	45	M2182P-1250AR	31005450
13,00	14	230	182	166	45	M2182P-1300AR	31005452
13,50	14	230	182	166	45	M2182P-1350AR	31005453
14,00	14	230	182	166	45	M2182P-1400AR	31005455
14,50	16	260	208	192	48	M2182P-1450AR	31005456
15,00	16	260	208	192	48	M2182P-1500AR	31005458
16,00	16	260	208	192	48	M2182P-1600AR	31005461
16,50	18	285	234	216	48	M2182P-1650AR	31005462
17,50	18	285	234	216	48	M2182P-1750AR	31005465
19,50	20	310	258	240	50	M2182P-1950AR	31005471

Fortsetzung auf nächster Seite.

## MEGA-Quadro-Drill-Plus | Vollhartmetall-Spiralbohrer M2182P (12xD), innere Kühlmittelzufuhr

## Konfigurierbare Merkmale

**Durchmesser:**

Durchmesser in Abstufungen  
von 0,01 mm frei wählbar

**Schaftform:**

Schaftform: HB | HE

**Spezifikation:**

M2182P-[Durchmesser][Schaftform]R

## Abmessungen konfigurierbare Baureihe

d <sub>1</sub> min.	d <sub>1</sub> max.	d <sub>2</sub> h6	l <sub>1</sub>	l <sub>2</sub>	l <sub>3</sub>	l <sub>4</sub>
3,00	3,70	6	92	54	48	36
3,71	4,70	6	102	64	58	36
4,71	6,00	6	116	78	70	36
6,01	8,00	8	146	108	94	36
8,01	10,00	10	162	120	110	40
10,01	12,00	12	204	156	142	45
12,01	14,00	14	230	182	166	45
14,01	16,00	16	260	208	192	48
16,01	18,00	18	285	234	216	48
18,01	20,00	20	310	258	240	50

**Beispiel:**

M2182P-0431ER

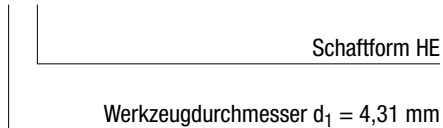

# MICRO-Drill-Steel

Vollhartmetall-Spiralbohrer  
M1925 (5xD), innere Kühlmittelzufuhr

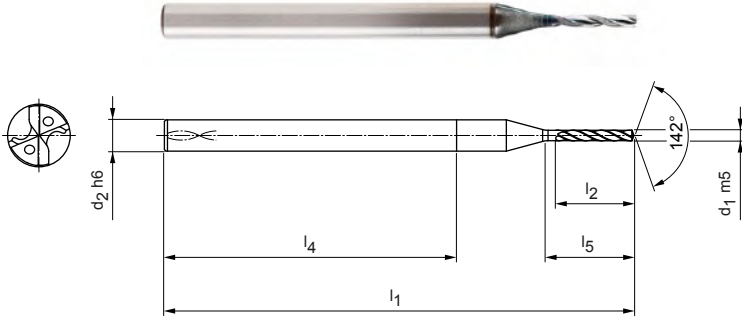

**Ausführung:**  
Bohrerdurchmesser: 0,80 - 2,99 mm  
Bohrungstoleranz: IT9 (erreichbar)  
Beschichtung: Mx15  
Schneidenanzahl: 2  
Anzahl Führungsfasen: 4  
Spitzenwinkel: 142°  
Spiralwinkel: 30°

**Anwendung:**  
Speziell auf MEGA-Deep-Drill abgestimmter Pilotbohrer.  
Maximal einsetzbar bis < Durchmesser 3,00 mm.



## Lagerhaltige Vorzugsbaureihe in Schaftform HA

Baumaße						Schaftform HA	
d <sub>1</sub> m5	d <sub>2</sub> h6	l <sub>1</sub>	l <sub>2</sub>	l <sub>3</sub>	l <sub>4</sub>	Spezifikation	Bestell-Nr.
0,80	3	45	6	4	28	M1925-0080A04	31238808
1,00	3	45	7,5	5	28	M1925-0100A04	31238830
1,20	3	45	9	6	28	M1925-0120A04	31238832
1,50	3	45	11,3	7,5	28	M1925-0150A04	31238835
1,60	3	50	12	8	28	M1925-0160A04	31238836
2,00	3	50	15	10	28	M1925-0200A04	31238840
2,40	3	52	18	12	28	M1925-0240A04	31238844
2,50	3	52	18,8	12,5	28	M1925-0250A04	31238845
2,60	3	55	19,5	13	28	M1925-0260A04	31238846
2,80	3	55	21	14	28	M1925-0280A04	31238848

## Konfigurierbare Merkmale

**Durchmesser:**  
Durchmesser in Abstufungen von 0,01 mm frei wählbar

**Spezifikation:**  
M1925-[Durchmesser]A04

## Abmessungen konfigurierbare Baureihe

d <sub>1</sub> min.	d <sub>1</sub> max.	d <sub>2</sub> h6	l <sub>1</sub>	l <sub>2</sub>	l <sub>3</sub>	l <sub>4</sub>
0,80	0,99	3	45	6,0	4,0	28
1,00	1,29	3	45	7,5	5,0	28
1,30	1,59	3	45	9,8	6,5	28
1,60	1,89	3	50	12,0	8,0	28
1,90	2,19	3	50	14,3	9,5	28
2,20	2,59	3	52	16,5	11,0	28
2,60	2,99	3	55	19,5	13,0	28

**Beispiel:**  
M1925-0221A04

Werkzeugdurchmesser d<sub>1</sub> = 2,21 mm

Maßangaben in mm.  
Schnittwertempfehlung siehe Kapitelende.  
Sonderausführungen und andere Beschichtungen auf Anfrage.

# MICRO-Drill-Steel

Vollhartmetall-Spiralbohrer  
M1928 (8xD), innere Kühlmittelzufuhr

## Ausführung:

Bohrerdurchmesser: 1,00 m 2,99 mm  
Bohrungstoleranz: IT9 (erreichbar)  
Beschichtung: Mx15  
Schneidenanzahl: 2  
Anzahl Führungsfasen: 4  
Spitzenwinkel: 142°  
Spiralwinkel: 30°

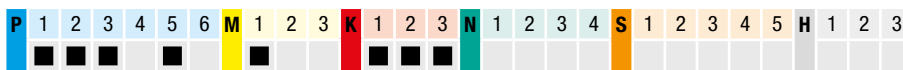
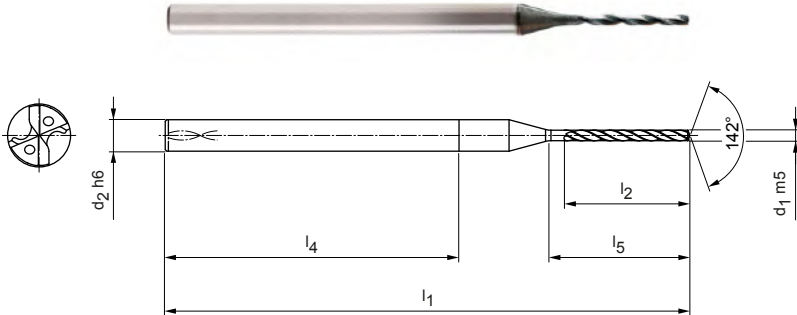

## Lagerhaltige Vorzugsbaureihe in Schaftform HA

Baumaße						Schaftform HA	
d <sub>1</sub> m5	d <sub>2</sub> h6	l <sub>1</sub>	l <sub>2</sub>	l <sub>3</sub>	l <sub>4</sub>	Spezifikation	Bestell-Nr.
1,00	3	50	12	8	28	M1928-0100A04	31238850
1,20	3	50	14,4	9,6	28	M1928-0120A04	31238852
1,50	3	52	18	12	28	M1928-0150A04	31238855
1,60	3	55	19,2	12,8	28	M1928-0160A04	31238856
2,00	3	60	24	16	28	M1928-0200A04	31238860
2,50	3	62	30	20	28	M1928-0250A04	31238865

## Konfigurierbare Merkmale



### Durchmesser:

Durchmesser in Abstufungen  
von 0,01 mm frei wählbar



### Spezifikation:

M1928-[Durchmesser]A04

Beispiel:  
M1928-0221A04

Werkzeugdurchmesser d<sub>1</sub> = 2,21 mm

## Abmessungen konfigurierbare Baureihe

d <sub>1</sub> min.	d <sub>1</sub> max.	d <sub>2</sub> h6	l <sub>1</sub>	l <sub>2</sub>	l <sub>3</sub>	l <sub>4</sub>
1,00	1,29	3	50	12,0	8,0	28
1,30	1,59	3	52	15,6	10,4	28
1,60	1,89	3	55	19,2	12,8	28
1,90	2,19	3	60	22,8	15,2	28
2,20	2,59	3	62	26,4	17,6	28
2,60	2,99	3	66	31,2	20,8	28

Maßangaben in mm.

Schnittwertempfehlung siehe Kapitelende.

Sonderausführungen und andere Beschichtungen auf Anfrage.

# MICRO-Drill-Steel

Vollhartmetall-Spiralbohrer  
M1932 (12xD), innere Kühlmittelzufuhr

**Ausführung:**  
Bohrerdurchmesser: 1,00 m 2,99 mm  
Bohrungstoleranz: IT9 (erreichbar)  
Beschichtung: Mx15  
Schneidenanzahl: 2  
Anzahl Führungsfasen: 4  
Spitzenwinkel: 142°  
Spiralwinkel: 30°

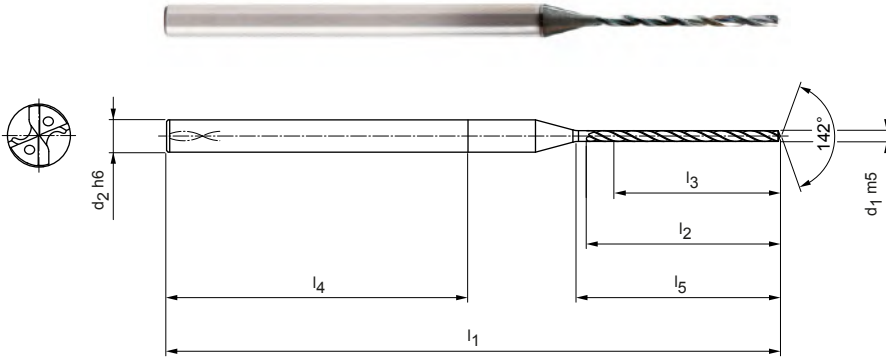

## Lagerhaltige Vorzugsbaureihe in Schaftform HA

Baumaße						Schaftform HA	
d <sub>1</sub> m5	d <sub>2</sub> h6	l <sub>1</sub>	l <sub>2</sub>	l <sub>3</sub>	l <sub>4</sub>	Spezifikation	Bestell-Nr.
1,00	3	57	18	12	28	M1932-0100A04	31238870
1,20	3	57	21,6	14,4	28	M1932-0120A04	31238872
1,30	3	62	23,4	15,6	28	M1932-0130A04	31238873
1,50	3	62	27	18	28	M1932-0150A04	31238875
2,00	3	72	36	24	28	M1932-0200A04	31238880
2,50	3	79	45	30	28	M1932-0250A04	31238885

## Konfigurierbare Merkmale



**Durchmesser:**  
Durchmesser in Abstufungen  
von 0,01 mm frei wählbar



**Spezifikation:**  
M1932-[Durchmesser]A04

## Abmessungen konfigurierbare Baureihe

d <sub>1</sub> min.	d <sub>1</sub> max.	d <sub>2</sub> h6	l <sub>1</sub>	l <sub>2</sub>	l <sub>3</sub>	l <sub>4</sub>
1,00	1,29	3	57	18,0	12,0	28
1,30	1,59	3	62	23,4	15,6	28
1,60	1,89	3	66	28,8	19,2	28
1,90	2,19	3	72	34,2	22,8	28
2,20	2,59	3	79	39,6	26,4	28
2,60	2,99	3	85	46,8	31,2	28

**Beispiel:**  
M1932-0221A04

Werkzeugdurchmesser d<sub>1</sub> = 2,21 mm

Maßangaben in mm.  
Schnittwertempfehlung siehe Kapitelende.  
Sonderausführungen und andere Beschichtungen auf Anfrage.

# MEGA-Drill-Hardened

Vollhartmetall-Spiralbohrer  
M1603 (3xD)

**Ausführung:**  
Bohrerdurchmesser: 2,55 - 20,00 mm  
Bohrungstoleranz: IT 9 (erreichbar)  
Beschichtung: Mx6  
Schneidenanzahl: 2  
Anzahl Führungsfasen: 2  
Spitzenwinkel: 140°  
Spiralwinkel: 15°

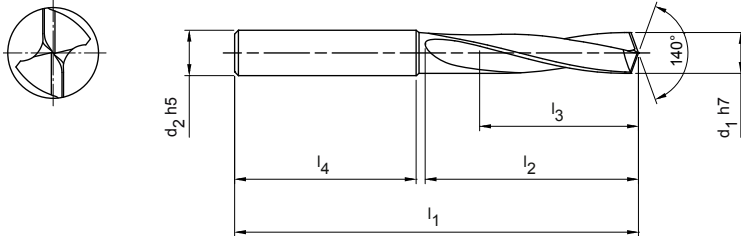

**Lagerhaltige Vorzugsbaureihe in Schaftform HA**

Baumaße						Schaftform HA	
d <sub>1</sub> h7	d <sub>2</sub> h5	l <sub>1</sub>	l <sub>2</sub>	l <sub>3</sub>	l <sub>4</sub>	Spezifikation	Bestell-Nr.
2,55	6	62	20	14	36	M1603-0255A07	31195442
2,60	6	62	20	14	36	M1603-0260A07	31195447
2,70	6	62	20	14	36	M1603-0270A07	31195449
2,80	6	62	20	14	36	M1603-0280A07	31195480
2,90	6	62	20	14	36	M1603-0290A07	31195482
3,00	6	62	20	14	36	M1603-0300A07	31151200
3,10	6	62	20	14	36	M1603-0310A07	31151201
3,20	6	62	20	14	36	M1603-0320A07	31151202
3,30	6	62	20	14	36	M1603-0330A07	31151203
3,40	6	62	20	14	36	M1603-0340A07	31151204
3,50	6	62	20	14	36	M1603-0350A07	31151205
3,60	6	62	20	14	36	M1603-0360A07	31151206
3,70	6	62	20	14	36	M1603-0370A07	31151207
3,80	6	66	24	17	36	M1603-0380A07	31151208
3,90	6	66	24	17	36	M1603-0390A07	31151209
4,00	6	66	24	17	36	M1603-0400A07	31151210
4,10	6	66	24	17	36	M1603-0410A07	31151211
4,20	6	66	24	17	36	M1603-0420A07	31151212
4,30	6	66	24	17	36	M1603-0430A07	31151213
4,40	6	66	24	17	36	M1603-0440A07	31151214
4,50	6	66	24	17	36	M1603-0450A07	31151215
4,60	6	66	24	17	36	M1603-0460A07	31151216
4,70	6	66	24	17	36	M1603-0470A07	31151218
4,80	6	66	28	20	36	M1603-0480A07	31151219
4,90	6	66	28	20	36	M1603-0490A07	31151220
5,00	6	66	28	20	36	M1603-0500A07	31151221
5,10	6	66	28	20	36	M1603-0510A07	31151222
5,20	6	66	28	20	36	M1603-0520A07	31151223
5,30	6	66	28	20	36	M1603-0530A07	31151224
5,40	6	66	28	20	36	M1603-0540A07	31151225
5,50	6	66	28	20	36	M1603-0550A07	31151226
5,55	6	66	28	20	36	M1603-0555A07	31151227
5,60	6	66	28	20	36	M1603-0560A07	31151228
5,70	6	66	28	20	36	M1603-0570A07	31151229
5,80	6	66	28	20	36	M1603-0580A07	31151230



## MEGA-Drill-Hardened | Vollhartmetall-Spiralbohrer M1603 (3xD)

Baumaße						Schaftform HA	
d <sub>1</sub> h7	d <sub>2</sub> h6	l <sub>1</sub>	l <sub>2</sub>	l <sub>3</sub>	l <sub>4</sub>	Spezifikation	Bestell-Nr.
5,90	6	66	28	20	36	M1603-0590A07	31151231
6,00	6	66	28	20	36	M1603-0600A07	31151232
6,10	8	79	34	24	36	M1603-0610A07	31151233
6,20	8	79	34	24	36	M1603-0620A07	31151234
6,30	8	79	34	24	36	M1603-0630A07	31151235
6,40	8	79	34	24	36	M1603-0640A07	31151236
6,50	8	79	34	24	36	M1603-0650A07	31151237
6,60	8	79	34	24	36	M1603-0660A07	31151238
6,70	8	79	34	24	36	M1603-0670A07	31151239
6,80	8	79	34	24	36	M1603-0680A07	31151240
6,90	8	79	34	24	36	M1603-0690A07	31151241
7,00	8	79	34	24	36	M1603-0700A07	31151242
7,10	8	79	41	29	36	M1603-0710A07	31151243
7,30	8	79	41	29	36	M1603-0730A07	31151245
7,40	8	79	41	29	36	M1603-0740A07	31151246
7,50	8	79	41	29	36	M1603-0750A07	31151247
7,80	8	79	41	29	36	M1603-0780A07	31151250
7,90	8	79	41	29	36	M1603-0790A07	31151251
8,00	8	79	41	29	36	M1603-0800A07	31151252
8,10	10	89	47	35	40	M1603-0810A07	31151253
8,20	10	89	47	35	40	M1603-0820A07	31151254
8,50	10	89	47	35	40	M1603-0850A07	31151257
8,60	10	89	47	35	40	M1603-0860A07	31151258
8,80	10	89	47	35	40	M1603-0880A07	31151260
9,00	10	89	47	35	40	M1603-0900A07	31151262
9,30	10	89	47	35	40	M1603-0930A07	31151265
9,50	10	89	47	35	40	M1603-0950A07	31151267
9,60	10	89	47	35	40	M1603-0960A07	31151268
9,70	10	89	47	35	40	M1603-0970A07	31151269
9,80	10	89	47	35	40	M1603-0980A07	31151270
10,00	10	89	47	35	40	M1603-1000A07	31151272
10,10	12	102	55	40	45	M1603-1010A07	31151273
10,20	12	102	55	40	45	M1603-1020A07	31151274
10,30	12	102	55	40	45	M1603-1030A07	31151275
10,40	12	102	55	40	45	M1603-1040A07	31151276
10,50	12	102	55	40	45	M1603-1050A07	31151277
11,00	12	102	55	40	45	M1603-1100A07	31151282
11,50	12	102	55	40	45	M1603-1150A07	31151287
11,80	12	102	55	40	45	M1603-1180A07	31151290
11,90	12	102	55	40	45	M1603-1190A07	31151291
12,00	12	102	55	40	45	M1603-1200A07	31151292
12,50	14	107	60	43	45	M1603-1250A07	31151294
12,80	14	107	60	43	45	M1603-1280A07	31151295
13,00	14	107	60	43	45	M1603-1300A07	31151296
13,50	14	107	60	43	45	M1603-1350A07	31151297
14,00	14	107	60	43	45	M1603-1400A07	31151299
14,20	16	115	65	45	48	M1603-1420A07	31151300
14,50	16	115	65	45	48	M1603-1450A07	31151301
14,80	16	115	65	45	48	M1603-1480A07	31151302
15,00	16	115	65	45	48	M1603-1500A07	31151303
15,50	16	115	65	45	48	M1603-1550A07	31151305
16,00	16	115	65	45	48	M1603-1600A07	31151307
17,50	18	123	73	51	48	M1603-1750A07	31151311

Fortsetzung auf nächster Seite.

## MEGA-Drill-Hardened | Vollhartmetall-Spiralbohrer M1603 (3xD)

## Konfigurierbare Merkmale



**Durchmesser:**  
Durchmesser in Abstufungen  
von 0,01 mm frei wählbar



**Schaftform:**  
Schaftform: HB | HE

**Spezifikation:**

M1603-[Durchmesser][Schaftform]07

**Beispiel:**

M1603-0431E07

Schaftform HE

Werkzeughdurchmesser  $d_1 = 4,31$  mm

## Abmessungen konfigurierbare Baureihe

$d_1$ min.	$d_1$ max.	$d_2$ h6	$l_1$	$l_2$	$l_3$	$l_4$
2,55	3,79	6	62	20	14	36
3,80	4,79	6	66	24	17	36
4,80	6,00	6	66	28	20	36
6,01	7,00	8	79	34	24	36
7,01	8,00	8	79	41	29	36
8,01	10,00	10	89	47	35	40
10,01	12,00	12	102	55	40	45
12,01	14,00	14	107	60	43	45
14,01	16,00	16	115	65	45	48
16,01	18,00	18	123	73	51	48
18,01	20,00	20	131	79	55	50

# Tritan-Drill-Steel

Vollhartmetall-Spiralbohrer  
M9933 (3xD), innere Kühlmittelzufuhr

**Ausführung:**  
Bohrerdurchmesser: 4,00 - 20,00 mm  
Bohrungstoleranz:  $\geq$  IT 9  
Beschichtung: MxP  
Schneidenanzahl: 3  
Anzahl Führungsfasen: 3  
Spitzenwinkel: 145°  
Spiralwinkel: 30°

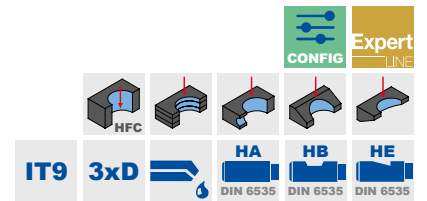
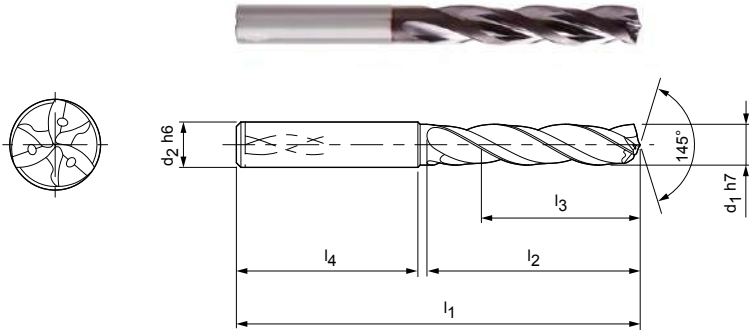

## Lagerhaltige Vorzugsbaureihe in Schaftform HA

Baumaße						Schaftform HA	
d <sub>1</sub> h7	d <sub>2</sub> h6	l <sub>1</sub>	l <sub>2</sub>	l <sub>3</sub>	l <sub>4</sub>	Spezifikation	Bestell-Nr.
4,00	6	66	24	17	36	M9933-0400AR	30790215
4,10	6	66	24	17	36	M9933-0410AR	30790216
4,20	6	66	24	17	36	M9933-0420AR	30790217
4,30	6	66	24	17	36	M9933-0430AR	30790218
4,40	6	66	24	17	36	M9933-0440AR	30790219
4,50	6	66	24	17	36	M9933-0450AR	30790220
4,60	6	66	24	17	36	M9933-0460AR	30790221
4,65	6	66	24	17	36	M9933-0465AR	30862011
4,70	6	66	24	17	36	M9933-0470AR	30790222
4,80	6	66	28	20	36	M9933-0480AR	30790223
4,90	6	66	28	20	36	M9933-0490AR	30790224
5,00	6	66	28	20	36	M9933-0500AR	30790225
5,10	6	66	28	20	36	M9933-0510AR	30790226
5,20	6	66	28	20	36	M9933-0520AR	30790227
5,30	6	66	28	20	36	M9933-0530AR	30790228
5,40	6	66	28	20	36	M9933-0540AR	30790229
5,50	6	66	28	20	36	M9933-0550AR	30790230
5,55	6	66	28	20	36	M9933-0555AR	30862012
5,60	6	66	28	20	36	M9933-0560AR	30790231
5,70	6	66	28	20	36	M9933-0570AR	30790232
5,80	6	66	28	20	36	M9933-0580AR	30790233
5,90	6	66	28	20	36	M9933-0590AR	30790234
6,00	6	66	28	20	36	M9933-0600AR	30790235
6,10	8	79	34	24	36	M9933-0610AR	30790236
6,20	8	79	34	24	36	M9933-0620AR	30790237
6,30	8	79	34	24	36	M9933-0630AR	30790238
6,35	8	79	34	24	36	M9933-0635AR	31087488
6,40	8	79	34	24	36	M9933-0640AR	30790239
6,50	8	79	34	24	36	M9933-0650AR	30790240
6,60	8	79	34	24	36	M9933-0660AR	30790241
6,70	8	79	34	24	36	M9933-0670AR	30790242
6,80	8	79	34	24	36	M9933-0680AR	30790243
6,90	8	79	34	24	36	M9933-0690AR	30790244
7,00	8	79	34	24	36	M9933-0700AR	30790245
7,10	8	79	41	29	36	M9933-0710AR	30790246

## Tritan-Drill-Steel | Vollhartmetall-Spiralbohrer M9933 (3xD), innere Kühlmittelzufuhr

Baumaße						Schaftform HA	
d <sub>1</sub> h7	d <sub>2</sub> h6	l <sub>1</sub>	l <sub>2</sub>	l <sub>3</sub>	l <sub>4</sub>	Spezifikation	Bestell-Nr.
7,20	8	79	41	29	36	M9933-0720AR	30790247
7,30	8	79	41	29	36	M9933-0730AR	30790248
7,40	8	79	41	29	36	M9933-0740AR	30790249
7,45	8	79	41	29	36	M9933-0745AR	30862013
7,50	8	79	41	29	36	M9933-0750AR	30790250
7,60	8	79	41	29	36	M9933-0760AR	30790251
7,70	8	79	41	29	36	M9933-0770AR	30790252
7,80	8	79	41	29	36	M9933-0780AR	30790253
7,90	8	79	41	29	36	M9933-0790AR	30790254
8,00	8	79	41	29	36	M9933-0800AR	30790255
8,10	10	89	47	35	40	M9933-0810AR	30790256
8,20	10	89	47	35	40	M9933-0820AR	30790257
8,30	10	89	47	35	40	M9933-0830AR	30790258
8,40	10	89	47	35	40	M9933-0840AR	30790259
8,50	10	89	47	35	40	M9933-0850AR	30790260
8,60	10	89	47	35	40	M9933-0860AR	30790261
8,70	10	89	47	35	40	M9933-0870AR	30790262
8,80	10	89	47	35	40	M9933-0880AR	30790263
9,00	10	89	47	35	40	M9933-0900AR	30790265
9,10	10	89	47	35	40	M9933-0910AR	30790266
9,20	10	89	47	35	40	M9933-0920AR	30790267
9,30	10	89	47	35	40	M9933-0930AR	30790268
9,35	10	89	47	35	40	M9933-0935AR	31189005
9,40	10	89	47	35	40	M9933-0940AR	30790269
9,50	10	89	47	35	40	M9933-0950AR	30790270
9,60	10	89	47	35	40	M9933-0960AR	30790271
9,70	10	89	47	35	40	M9933-0970AR	30790272
9,80	10	89	47	35	40	M9933-0980AR	30790273
9,90	10	89	47	35	40	M9933-0990AR	30790274
10,00	10	89	47	35	40	M9933-1000AR	30790275
10,10	12	102	55	40	45	M9933-1010AR	30790276
10,20	12	102	55	40	45	M9933-1020AR	30790277
10,30	12	102	55	40	45	M9933-1030AR	30790278
10,40	12	102	55	40	45	M9933-1040AR	30790279
10,50	12	102	55	40	45	M9933-1050AR	30790280
10,80	12	102	55	40	45	M9933-1080AR	30790283
10,90	12	102	55	40	45	M9933-1090AR	30790284
11,00	12	102	55	40	45	M9933-1100AR	30790285
11,10	12	102	55	40	45	M9933-1110AR	30790286
11,20	12	102	55	40	45	M9933-1120AR	30790287
11,30	12	102	55	40	45	M9933-1130AR	30790288
11,40	12	102	55	40	45	M9933-1140AR	30790289
11,50	12	102	55	40	45	M9933-1150AR	30790290
11,60	12	102	55	40	45	M9933-1160AR	30790291
11,70	12	102	55	40	45	M9933-1170AR	30790292
11,80	12	102	55	40	45	M9933-1180AR	30790293
11,90	12	102	55	40	45	M9933-1190AR	30790294
12,00	12	102	55	40	45	M9933-1200AR	30790295
12,20	14	107	60	43	45	M9933-1220AR	30790491
12,23	14	107	60	43	45	M9933-1223AR	31271255
12,50	14	107	60	43	45	M9933-1250AR	30790296
12,70	14	107	60	43	45	M9933-1270AR	31087530
13,00	14	107	60	43	45	M9933-1300AR	30790298
13,50	14	107	60	43	45	M9933-1350AR	30790299
13,80	14	107	60	43	45	M9933-1380AR	30790300
14,00	14	107	60	43	45	M9933-1400AR	30790301
14,20	16	115	65	45	48	M9933-1420AR	30790492

## Tritan-Drill-Steel | Vollhartmetall-Spiralbohrer M9933 (3xD), innere Kühlmittelzufuhr

Baumaße						Schaffform HA	
d <sub>1</sub> h7	d <sub>2</sub> h6	l <sub>1</sub>	l <sub>2</sub>	l <sub>3</sub>	l <sub>4</sub>	Spezifikation	Bestell-Nr.
14,50	16	115	65	45	48	M9933-1450AR	30790302
14,80	16	115	65	45	48	M9933-1480AR	30790303
15,00	16	115	65	45	48	M9933-1500AR	30790304
15,20	16	115	65	45	48	M9933-1520AR	30790493
15,50	16	115	65	45	48	M9933-1550AR	30790305
15,80	16	115	65	45	48	M9933-1580AR	30790306
16,00	16	115	65	45	48	M9933-1600AR	30790307
16,20	18	123	73	51	48	M9933-1620AR	30790723
16,50	18	123	73	51	48	M9933-1650AR	30790308
17,00	18	123	73	51	48	M9933-1700AR	30790310
17,35	18	123	73	51	48	M9933-1735AR	30956801
17,50	18	123	73	51	48	M9933-1750AR	30790311
17,80	18	123	73	51	48	M9933-1780AR	30790312
18,00	18	123	73	51	48	M9933-1800AR	30790313
18,50	20	131	79	55	50	M9933-1850AR	30790314
18,80	20	131	79	55	50	M9933-1880AR	30790315
19,00	20	131	79	55	50	M9933-1900AR	30790316
19,50	20	131	79	55	50	M9933-1950AR	30790317
20,00	20	131	79	55	50	M9933-2000AR	30790319

## Konfigurierbare Merkmale



**Durchmesser:**  
Durchmesser in Abstufungen  
von 0,01 mm frei wählbar



**Schaffform:**  
Schaffform: HB | HE

**Spezifikation:**

M9933-[Durchmesser][Schaffform]R

## Abmessungen konfigurierbare Baureihe

d <sub>1</sub> min.	d <sub>1</sub> max.	d <sub>2</sub> h6	l <sub>1</sub>	l <sub>2</sub>	l <sub>3</sub>	l <sub>4</sub>
4,00	4,70	6	66	24	17	36
4,71	6,00	6	66	28	20	36
6,01	7,00	8	79	34	24	36
7,01	8,00	8	79	41	29	36
8,01	10,00	10	89	47	35	40
10,01	12,00	12	102	55	40	45
12,01	14,00	14	107	60	43	45
14,01	16,00	16	115	65	45	48
16,01	18,00	18	123	73	51	48
18,01	20,00	20	131	79	55	50

**Beispiel:**  
M9933-0431ER

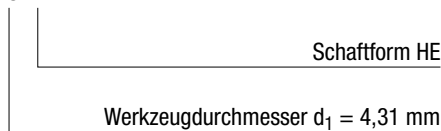

Maßangaben in mm.

Schnittwertempfehlung siehe Kapitelende.

Sonderausführungen und andere Beschichtungen auf Anfrage.

# Tritan-Drill-Steel

Vollhartmetall-Spiralbohrer  
M9935 (5xD), innere Kühlmittelzufuhr

## Ausführung:

Bohrerdurchmesser: 4,00 - 20,00 mm  
Bohrungstoleranz:  $\geq$  IT 9  
Beschichtung: MxP  
Schneidenanzahl: 3  
Anzahl Führungsfasen: 3  
Spitzenwinkel: 145°  
Spiralwinkel: 30°

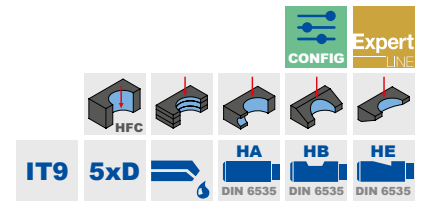
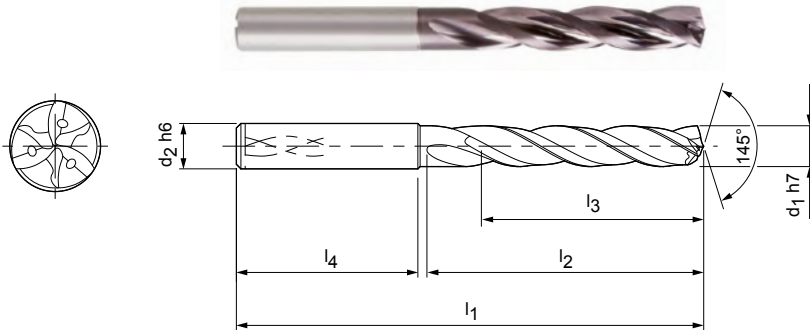

## Lagerhaltige Vorzugsbaureihe in Schaftform HA

Baumaße						Schaftform HA	
d <sub>1</sub> h7	d <sub>2</sub> h6	l <sub>1</sub>	l <sub>2</sub>	l <sub>3</sub>	l <sub>4</sub>	Spezifikation	Bestell-Nr.
4,00	6	74	36	29	36	M9935-0400AR	30790320
4,10	6	74	36	29	36	M9935-0410AR	30790321
4,20	6	74	36	29	36	M9935-0420AR	30790322
4,30	6	74	36	29	36	M9935-0430AR	30790323
4,40	6	74	36	29	36	M9935-0440AR	30790324
4,50	6	74	36	29	36	M9935-0450AR	30790325
4,60	6	74	36	29	36	M9935-0460AR	30790326
4,65	6	74	36	29	36	M9935-0465AR	30862014
4,70	6	74	36	29	36	M9935-0470AR	30790327
4,80	6	82	44	35	36	M9935-0480AR	30790328
4,90	6	82	44	35	36	M9935-0490AR	30790329
5,00	6	82	44	35	36	M9935-0500AR	30790330
5,10	6	82	44	35	36	M9935-0510AR	30790331
5,20	6	82	44	35	36	M9935-0520AR	30790332
5,30	6	82	44	35	36	M9935-0530AR	30790333
5,40	6	82	44	35	36	M9935-0540AR	30790334
5,50	6	82	44	35	36	M9935-0550AR	30790335
5,55	6	82	44	35	36	M9935-0555AR	30862015
5,60	6	82	44	35	36	M9935-0560AR	30790336
5,70	6	82	44	35	36	M9935-0570AR	30790337
5,80	6	82	44	35	36	M9935-0580AR	30790338
5,90	6	82	44	35	36	M9935-0590AR	30790339
6,00	6	82	44	35	36	M9935-0600AR	30790340
6,05	8	91	53	43	36	M9935-0605AR	31203101
6,10	8	91	53	43	36	M9935-0610AR	30790341
6,20	8	91	53	43	36	M9935-0620AR	30790342
6,30	8	91	53	43	36	M9935-0630AR	30790343
6,40	8	91	53	43	36	M9935-0640AR	30790344
6,50	8	91	53	43	36	M9935-0650AR	30790345
6,60	8	91	53	43	36	M9935-0660AR	30790346
6,80	8	91	53	43	36	M9935-0680AR	30790348
6,90	8	91	53	43	36	M9935-0690AR	30790349
7,00	8	91	53	43	36	M9935-0700AR	30790350
7,10	8	91	53	43	36	M9935-0710AR	30790351
7,20	8	91	53	43	36	M9935-0720AR	30790352

## Tritan-Drill-Steel | Vollhartmetall-Spiralbohrer M9935 (5xD), innere Kühlmittelzufuhr

Baumaße						Schaftform HA	
d <sub>1</sub> h7	d <sub>2</sub> h6	l <sub>1</sub>	l <sub>2</sub>	l <sub>3</sub>	l <sub>4</sub>	Spezifikation	Bestell-Nr.
7,30	8	91	53	43	36	M9935-0730AR	30790353
7,40	8	91	53	43	36	M9935-0740AR	30790354
7,45	8	91	53	43	36	M9935-0745AR	30862016
7,50	8	91	53	43	36	M9935-0750AR	30790355
7,60	8	91	53	43	36	M9935-0760AR	30790356
7,70	8	91	53	43	36	M9935-0770AR	30790357
7,80	8	91	53	43	36	M9935-0780AR	30790358
7,90	8	91	53	43	36	M9935-0790AR	30790359
8,00	8	91	53	43	36	M9935-0800AR	30790360
8,10	10	103	61	49	40	M9935-0810AR	30790361
8,20	10	103	61	49	40	M9935-0820AR	30790362
8,30	10	103	61	49	40	M9935-0830AR	30790363
8,40	10	103	61	49	40	M9935-0840AR	30790364
8,50	10	103	61	49	40	M9935-0850AR	30790365
8,60	10	103	61	49	40	M9935-0860AR	30790366
8,70	10	103	61	49	40	M9935-0870AR	30790367
8,80	10	103	61	49	40	M9935-0880AR	30790368
8,90	10	103	61	49	40	M9935-0890AR	30790369
9,00	10	103	61	49	40	M9935-0900AR	30790370
9,10	10	103	61	49	40	M9935-0910AR	30790371
9,20	10	103	61	49	40	M9935-0920AR	30790372
9,30	10	103	61	49	40	M9935-0930AR	30790373
9,35	10	103	61	49	40	M9935-0935AR	30862017
9,40	10	103	61	49	40	M9935-0940AR	30790374
9,50	10	103	61	49	40	M9935-0950AR	30790375
9,70	10	103	61	49	40	M9935-0970AR	30790377
9,80	10	103	61	49	40	M9935-0980AR	30790378
9,90	10	103	61	49	40	M9935-0990AR	30790379
10,00	10	103	61	49	40	M9935-1000AR	30790380
10,10	12	118	71	56	45	M9935-1010AR	30790381
10,20	12	118	71	56	45	M9935-1020AR	30790382
10,30	12	118	71	56	45	M9935-1030AR	30790383
10,40	12	118	71	56	45	M9935-1040AR	30790384
10,50	12	118	71	56	45	M9935-1050AR	30790385
10,80	12	118	71	56	45	M9935-1080AR	30790388
11,00	12	118	71	56	45	M9935-1100AR	30790390
11,10	12	118	71	56	45	M9935-1110AR	30790391
11,20	12	118	71	56	45	M9935-1120AR	30790392
11,30	12	118	71	56	45	M9935-1130AR	30790393
11,40	12	118	71	56	45	M9935-1140AR	30790394
11,50	12	118	71	56	45	M9935-1150AR	30790395
11,80	12	118	71	56	45	M9935-1180AR	30790398
11,90	12	118	71	56	45	M9935-1190AR	30790399
12,00	12	118	71	56	45	M9935-1200AR	30790400
12,20	14	124	77	60	45	M9935-1220AR	30790494
12,50	14	124	77	60	45	M9935-1250AR	30790401
12,80	14	124	77	60	45	M9935-1280AR	30790402
13,00	14	124	77	60	45	M9935-1300AR	30790403
13,50	14	124	77	60	45	M9935-1350AR	30790404
13,80	14	124	77	60	45	M9935-1380AR	30790405
14,00	14	124	77	60	45	M9935-1400AR	30790406
14,20	16	133	83	63	48	M9935-1420AR	30790495
14,50	16	133	83	63	48	M9935-1450AR	30790407
14,80	16	133	83	63	48	M9935-1480AR	30790408
15,00	16	133	83	63	48	M9935-1500AR	30790409
15,10	16	133	83	63	48	M9935-1510AR	30862019
15,20	16	133	83	63	48	M9935-1520AR	30790496

Fortsetzung auf nächster Seite.

## Tritan-Drill-Steel | Vollhartmetall-Spiralbohrer M9935 (5xD), innere Kühlmittelzufuhr

Baumaße						Schaffform HA	
d <sub>1</sub> h7	d <sub>2</sub> h6	l <sub>1</sub>	l <sub>2</sub>	l <sub>3</sub>	l <sub>4</sub>	Spezifikation	Bestell-Nr.
15,25	16	133	83	63	48	M9935-1525AR	30862020
15,50	16	133	83	63	48	M9935-1550AR	30790410
15,80	16	133	83	63	48	M9935-1580AR	30790411
16,00	16	133	83	63	48	M9935-1600AR	30790412
16,20	18	143	93	71	48	M9935-1620AR	30790728
16,50	18	143	93	71	48	M9935-1650AR	30790413
16,80	18	143	93	71	48	M9935-1680AR	30790414
17,00	18	143	93	71	48	M9935-1700AR	30790415
17,50	18	143	93	71	48	M9935-1750AR	30790416
18,00	18	143	93	71	48	M9935-1800AR	30790418
18,50	20	153	101	77	50	M9935-1850AR	30790419
18,80	20	153	101	77	50	M9935-1880AR	30790420
19,00	20	153	101	77	50	M9935-1900AR	30790421
19,50	20	153	101	77	50	M9935-1950AR	30790422
19,80	20	153	101	77	50	M9935-1980AR	30790423
20,00	20	153	101	77	50	M9935-2000AR	30790424

## Konfigurierbare Merkmale

**Durchmesser:**

Durchmesser in Abstufungen  
von 0,01 mm frei wählbar

**Schaffform:**

Schaffform: HB | HE

**Spezifikation:**

M9935-[Durchmesser][Schaffform]R

## Abmessungen konfigurierbare Baureihe

d <sub>1</sub> min.	d <sub>1</sub> max.	d <sub>2</sub> h6	l <sub>1</sub>	l <sub>2</sub>	l <sub>3</sub>	l <sub>4</sub>
4,00	4,70	6	74	36	29	36
4,71	6,00	6	82	44	35	36
6,01	8,00	8	91	53	43	36
8,01	10,00	10	103	61	49	40
10,01	12,00	12	118	71	56	45
12,01	14,00	14	124	77	60	45
14,01	16,00	16	133	83	63	48
16,01	18,00	18	143	93	71	48
18,01	20,00	20	153	101	77	50

**Beispiel:**  
M9935-0431ER

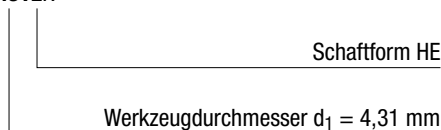

Maßangaben in mm.

Schnittwertempfehlung siehe Kapitelende.

Sonderausführungen und andere Beschichtungen auf Anfrage.



# Tritan-Drill-Steel

Vollhartmetall-Spiralbohrer  
M9938 (8xD), innere Kühlmittelzufuhr

**Ausführung:**

Bohrerdurchmesser: 4,00 - 20,00 mm  
Bohrungstoleranz:  $\geq IT 9$   
Beschichtung: MxP  
Schneidenanzahl: 3  
Anzahl Führungsfasen: 3  
Spitzenwinkel:  $140^\circ$   
Spiralwinkel:  $30^\circ$

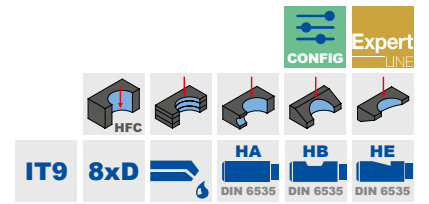
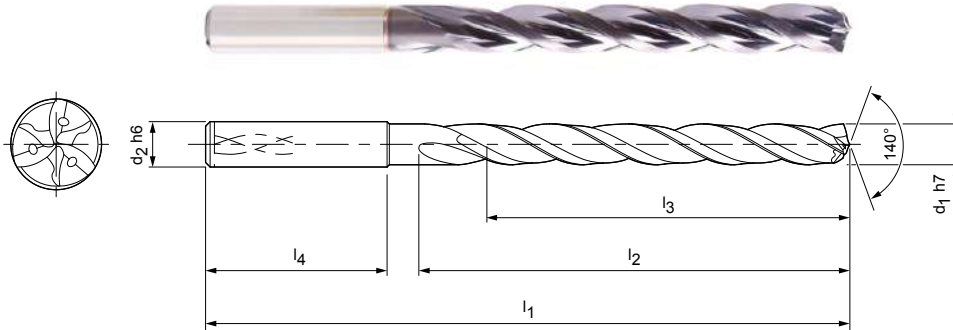

**Lagerhaltige Vorzugsbaureihe in Schaftform HA**

Baumaße						Schaftform HA	
d <sub>1</sub> h7	d <sub>2</sub> h6	l <sub>1</sub>	l <sub>2</sub>	l <sub>3</sub>	l <sub>4</sub>	Spezifikation	Bestell-Nr.
4,00	6	81	43	36	36	M9938-0400AR	30866502
4,10	6	81	43	36	36	M9938-0410AR	30866503
4,20	6	81	43	36	36	M9938-0420AR	30866504
4,30	6	81	43	36	36	M9938-0430AR	30866505
4,50	6	81	43	36	36	M9938-0450AR	30866507
4,60	6	81	43	36	36	M9938-0460AR	30866508
4,70	6	81	43	36	36	M9938-0470AR	30866509
4,80	6	95	57	48	36	M9938-0480AR	30866510
5,00	6	95	57	48	36	M9938-0500AR	30862021
5,10	6	95	57	48	36	M9938-0510AR	30862022
5,20	6	95	57	48	36	M9938-0520AR	30862023
5,40	6	95	57	48	36	M9938-0540AR	30862025
5,50	6	95	57	48	36	M9938-0550AR	30862026
5,60	6	95	57	48	36	M9938-0560AR	30862027
5,80	6	95	57	48	36	M9938-0580AR	30862029
5,90	6	95	57	48	36	M9938-0590AR	30862030
6,00	6	95	57	48	36	M9938-0600AR	30862031
6,10	8	114	76	64	36	M9938-0610AR	30862032
6,50	8	114	76	64	36	M9938-0650AR	30862036
6,60	8	114	76	64	36	M9938-0660AR	30862037
6,80	8	114	76	64	36	M9938-0680AR	30862039
6,90	8	114	76	64	36	M9938-0690AR	30862040
7,00	8	114	76	64	36	M9938-0700AR	30862041
7,50	8	114	76	64	36	M9938-0750AR	30862046
7,80	8	114	76	64	36	M9938-0780AR	30862049
7,90	8	114	76	64	36	M9938-0790AR	30862050
8,00	8	114	76	64	36	M9938-0800AR	30862051
8,10	10	142	95	80	40	M9938-0810AR	30862052
8,20	10	142	95	80	40	M9938-0820AR	30862053
8,50	10	142	95	80	40	M9938-0850AR	30862056
8,60	10	142	95	80	40	M9938-0860AR	30862057
8,80	10	142	95	80	40	M9938-0880AR	30862059
9,00	10	142	95	80	40	M9938-0900AR	30862061
9,10	10	142	95	80	40	M9938-0910AR	30862062
9,50	10	142	95	80	40	M9938-0950AR	30862066

## Tritan-Drill-Steel | Vollhartmetall-Spiralbohrer M9938 (8xD), innere Kühlmittelzufuhr

Baumaße						Schaftform HA	
d <sub>1</sub> h7	d <sub>2</sub> h6	l <sub>1</sub>	l <sub>2</sub>	l <sub>3</sub>	l <sub>4</sub>	Spezifikation	Bestell-Nr.
9,80	10	142	95	80	40	M9938-0980AR	30862069
10,00	10	142	95	80	40	M9938-1000AR	30862071
10,20	12	162	114	96	45	M9938-1020AR	30862073
10,30	12	162	114	96	45	M9938-1030AR	30862074
10,50	12	162	114	96	45	M9938-1050AR	30862076
11,00	12	162	114	96	45	M9938-1100AR	30862081
11,50	12	162	114	96	45	M9938-1150AR	30862086
11,80	12	162	114	96	45	M9938-1180AR	30862089
11,90	12	162	114	96	45	M9938-1190AR	30862090
12,00	12	162	114	96	45	M9938-1200AR	30862091
12,20	14	178	133	112	45	M9938-1220AR	30862092
12,50	14	178	133	112	45	M9938-1250AR	30862093
13,00	14	178	133	112	45	M9938-1300AR	30862095
13,50	14	178	133	112	45	M9938-1350AR	30862097
13,80	14	178	133	112	45	M9938-1380AR	30862098
14,00	14	178	133	112	45	M9938-1400AR	30862099
14,20	16	203	152	128	48	M9938-1420AR	30862100
14,50	16	203	152	128	48	M9938-1450AR	30862101
15,00	16	203	152	128	48	M9938-1500AR	30862103
15,50	16	203	152	128	48	M9938-1550AR	30862105
15,80	16	203	152	128	48	M9938-1580AR	30862106
16,00	16	203	152	128	48	M9938-1600AR	30862107
17,00	18	222	171	144	48	M9938-1700AR	30862111
17,50	18	222	171	144	48	M9938-1750AR	30862113
18,00	18	222	171	144	48	M9938-1800AR	30862115
18,50	20	243	190	160	50	M9938-1850AR	30862117
19,00	20	243	190	160	50	M9938-1900AR	30862119
19,20	20	243	190	160	50	M9938-1920AR	30862120
19,50	20	243	190	160	50	M9938-1950AR	30862121
20,00	20	243	190	160	50	M9938-2000AR	30862123

## Konfigurierbare Merkmale

**Durchmesser:**

Durchmesser in Abstufungen  
von 0,01 mm frei wählbar

**Schaftform:**

Schaftform: HB | HE

**Spezifikation:**

M9938-[Durchmesser][Schaftform]R

## Abmessungen konfigurierbare Baureihe

d <sub>1</sub> min.	d <sub>1</sub> max.	d <sub>2</sub> h6	l <sub>1</sub>	l <sub>2</sub>	l <sub>3</sub>	l <sub>4</sub>
4,00	4,70	6	81	43	36	36
4,71	6,00	6	95	57	48	36
6,01	8,00	8	114	76	64	36
8,01	10,00	10	142	95	80	40
10,01	12,00	12	162	114	96	45
12,01	14,00	14	178	133	112	45
14,01	16,00	16	203	152	128	48
16,01	18,00	18	222	171	144	48
18,01	20,00	20	243	190	160	50

Beispiel:  
M9938-0431ER

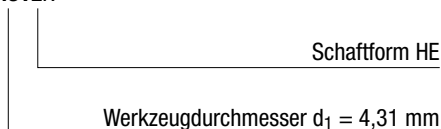

Maßangaben in mm.

Schnittwertempfehlung siehe Kapitelende.

Sonderausführungen und andere Beschichtungen auf Anfrage.

# Tritan-Drill-Steel

Vollhartmetall-Spiralbohrer  
M9942 (12xD), innere Kühlmittelzufuhr

**Ausführung:**

Bohrerdurchmesser: 4,00 - 20,00 mm  
Bohrungstoleranz:  $\geq IT 9$   
Beschichtung: MxP  
Schneidenanzahl: 3  
Anzahl Führungsfasen: 3  
Spitzenwinkel:  $140^\circ$   
Spiralwinkel:  $30^\circ$

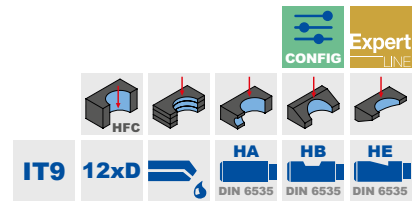
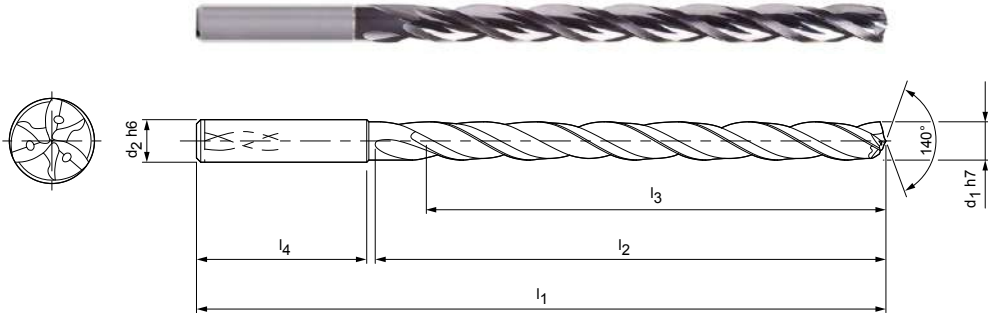

**Lagerhaltige Vorzugsbaureihe in Schaftform HA**

Baumaße						Schaftform HA	
d <sub>1</sub> h7	d <sub>2</sub> h6	l <sub>1</sub>	l <sub>2</sub>	l <sub>3</sub>	l <sub>4</sub>	Spezifikation	Bestell-Nr.
4,00	6	102	64	58	36	M9942-0400AR	30866512
4,10	6	102	64	58	36	M9942-0410AR	30866513
4,20	6	102	64	58	36	M9942-0420AR	30866514
4,30	6	102	64	58	36	M9942-0430AR	30866515
4,50	6	102	64	58	36	M9942-0450AR	30866517
4,60	6	102	64	58	36	M9942-0460AR	30866518
4,80	6	116	78	70	36	M9942-0480AR	30866520
5,00	6	116	78	70	36	M9942-0500AR	30862124
5,10	6	116	78	70	36	M9942-0510AR	30862125
5,20	6	116	78	70	36	M9942-0520AR	30862126
5,40	6	116	78	70	36	M9942-0540AR	30862128
5,50	6	116	78	70	36	M9942-0550AR	30862129
5,80	6	116	78	70	36	M9942-0580AR	30862132
5,90	6	116	78	70	36	M9942-0590AR	30862133
6,00	6	116	78	70	36	M9942-0600AR	30862134
6,10	8	146	108	94	36	M9942-0610AR	30862135
6,50	8	146	108	94	36	M9942-0650AR	30862139
6,80	8	146	108	94	36	M9942-0680AR	30862142
7,00	8	146	108	94	36	M9942-0700AR	30862144
7,50	8	146	108	94	36	M9942-0750AR	30862149
7,80	8	146	108	94	36	M9942-0780AR	30862152
7,90	8	146	108	94	36	M9942-0790AR	30862154
8,00	8	146	108	94	36	M9942-0800AR	30862155
8,20	10	162	120	110	40	M9942-0820AR	30862157
8,40	10	162	120	110	40	M9942-0840AR	30862159
8,50	10	162	120	110	40	M9942-0850AR	30862160
8,80	10	162	120	110	40	M9942-0880AR	30862163
9,00	10	162	120	110	40	M9942-0900AR	30862165
9,50	10	162	120	110	40	M9942-0950AR	30862170
9,60	10	162	120	110	40	M9942-0960AR	30862171
9,80	10	162	120	110	40	M9942-0980AR	30862173
10,00	10	162	120	110	40	M9942-1000AR	30862175
10,20	12	204	156	142	45	M9942-1020AR	30862177
10,30	12	204	156	142	45	M9942-1030AR	30862178
10,50	12	204	156	142	45	M9942-1050AR	30862180

## Tritan-Drill-Steel | Vollhartmetall-Spiralbohrer M9942 (12xD), innere Kühlmittelzufuhr

Baumaße						Schaftform HA	
d <sub>1</sub> h7	d <sub>2</sub> h6	l <sub>1</sub>	l <sub>2</sub>	l <sub>3</sub>	l <sub>4</sub>	Spezifikation	Bestell-Nr.
11,00	12	204	156	142	45	M9942-1100AR	30862186
11,50	12	204	156	142	45	M9942-1150AR	30862191
11,80	12	204	156	142	45	M9942-1180AR	30862194
12,00	12	204	156	142	45	M9942-1200AR	30862196
12,50	14	230	182	166	45	M9942-1250AR	30862198
13,00	14	230	182	166	45	M9942-1300AR	30862200
13,50	14	230	182	166	45	M9942-1350AR	30862202
14,00	14	230	182	166	45	M9942-1400AR	30862204
14,50	16	260	208	192	48	M9942-1450AR	30862206
15,00	16	260	208	192	48	M9942-1500AR	30862208
15,50	16	260	208	192	48	M9942-1550AR	30862210
16,00	16	260	208	192	48	M9942-1600AR	30862212
16,50	18	285	234	216	48	M9942-1650AR	30862214
17,00	18	285	234	216	48	M9942-1700AR	30862216
17,50	18	285	234	216	48	M9942-1750AR	30862218
18,00	18	285	234	216	48	M9942-1800AR	30862220
18,50	20	310	258	240	50	M9942-1850AR	30862222
19,00	20	310	258	240	50	M9942-1900AR	30862224
19,50	20	310	258	240	50	M9942-1950AR	30862226
20,00	20	310	258	240	50	M9942-2000AR	30862228

## Konfigurierbare Merkmale



**Durchmesser:**  
Durchmesser in Abstufungen  
von 0,01 mm frei wählbar



**Schaftform:**  
Schaftform: HB | HE

**Spezifikation:**

M9942-[Durchmesser][Schaftform]R

## Abmessungen konfigurierbare Baureihe

d <sub>1</sub> min.	d <sub>1</sub> max.	d <sub>2</sub> h6	l <sub>1</sub>	l <sub>2</sub>	l <sub>3</sub>	l <sub>4</sub>
4,00	4,70	6	102	64	58	36
4,71	6,00	6	116	78	70	36
6,01	8,00	8	146	108	94	36
8,01	10,00	10	162	120	110	40
10,01	12,00	12	204	156	142	45
12,01	14,00	14	230	182	166	45
14,01	16,00	16	260	208	192	48
16,01	18,00	18	285	234	216	48
18,01	20,00	20	310	258	240	50

**Beispiel:**  
M9942-0431ER

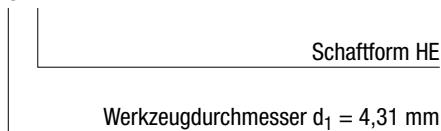

Maßangaben in mm.

Schnittwertempfehlung siehe Kapitelende.

Sonderausführungen und andere Beschichtungen auf Anfrage.

# MEGA-Speed-Drill-Steel

Vollhartmetall-Spiralbohrer

M9923 (3xD), innere Kühlmittelzufuhr, Nachfolgeprodukt des MEGA-Speed-Drill-Steel (M9103)

**Ausführung:**

- Bohrerdurchmesser: 3,00 - 20,00 mm
- Bohrungstoleranz: IT 9 (erreichbar)
- Beschichtung: MxP
- Schneidenanzahl: 2
- Anzahl Führungsfasen: 3
- Spitzenwinkel: 145°
- Spiralwinkel: 30°

**Anwendung:**

Für Hochgeschwindigkeitsbearbeitung.

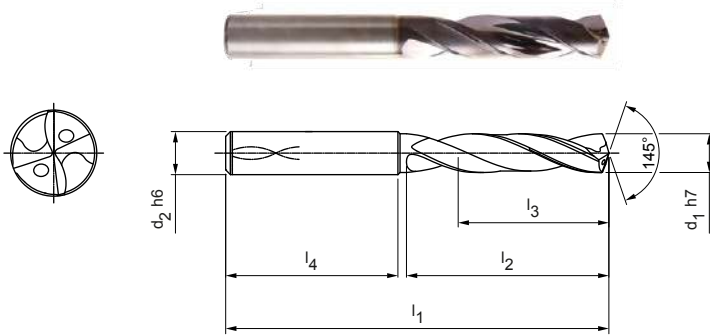

**Lagerhaltige Vorzugsbaureihe in Schaftform HA**

Baumaße						Schaftform HA	
d <sub>1</sub> h7	d <sub>2</sub> h6	l <sub>1</sub>	l <sub>2</sub>	l <sub>3</sub>	l <sub>4</sub>	Spezifikation	Bestell-Nr.
3,00	6	62	20	14	36	M9923-0300AR	31035899
3,20	6	62	20	14	36	M9923-0320AR	31035901
3,30	6	62	20	14	36	M9923-0330AR	31035902
3,40	6	62	20	14	36	M9923-0340AR	31035903
3,50	6	62	20	14	36	M9923-0350AR	31035904
3,70	6	62	20	14	36	M9923-0370AR	31035906
3,80	6	66	24	17	36	M9923-0380AR	31035907
3,90	6	66	24	17	36	M9923-0390AR	31035908
4,00	6	66	24	17	36	M9923-0400AR	31035909
4,10	6	66	24	17	36	M9923-0410AR	31035910
4,20	6	66	24	17	36	M9923-0420AR	31035911
4,30	6	66	24	17	36	M9923-0430AR	31035912
4,50	6	66	24	17	36	M9923-0450AR	31035914
4,60	6	66	24	17	36	M9923-0460AR	31035915
4,65	6	66	24	17	36	M9923-0465AR	31038700
4,70	6	66	24	17	36	M9923-0470AR	31035916
4,90	6	66	28	20	36	M9923-0490AR	31035918
5,00	6	66	28	20	36	M9923-0500AR	31035919
5,10	6	66	28	20	36	M9923-0510AR	31035920
5,20	6	66	28	20	36	M9923-0520AR	31035921
5,50	6	66	28	20	36	M9923-0550AR	31035924
5,60	6	66	28	20	36	M9923-0560AR	31035925
5,80	6	66	28	20	36	M9923-0580AR	31035927
5,90	6	66	28	20	36	M9923-0590AR	31035928
6,00	6	66	28	20	36	M9923-0600AR	31035929
6,10	8	79	34	24	36	M9923-0610AR	31035930
6,20	8	79	34	24	36	M9923-0620AR	31035931
6,30	8	79	34	24	36	M9923-0630AR	31035932
6,40	8	79	34	24	36	M9923-0640AR	31035933
6,50	8	79	34	24	36	M9923-0650AR	31035934
6,60	8	79	34	24	36	M9923-0660AR	31035935
6,80	8	79	34	24	36	M9923-0680AR	31035937
6,90	8	79	34	24	36	M9923-0690AR	31035938
7,00	8	79	34	24	36	M9923-0700AR	31035939
7,15	8	79	41	29	36	M9923-0715AR	31222377

**MEGA-Speed-Drill-Steel | Vollhartmetall-Spiralbohrer M9923 (3xD), innere Kühlmittelzufuhr**

Baumaße						Schaftform HA	
d <sub>1</sub> h7	d <sub>2</sub> h6	l <sub>1</sub>	l <sub>2</sub>	l <sub>3</sub>	l <sub>4</sub>	Spezifikation	Bestell-Nr.
7,30	8	79	41	29	36	M9923-0730AR	31035942
7,40	8	79	41	29	36	M9923-0740AR	31035943
7,50	8	79	41	29	36	M9923-0750AR	31035944
7,60	8	79	41	29	36	M9923-0760AR	31035945
7,70	8	79	41	29	36	M9923-0770AR	31035946
7,80	8	79	41	29	36	M9923-0780AR	31035947
8,00	8	79	41	29	36	M9923-0800AR	31035949
8,20	10	89	47	35	40	M9923-0820AR	31035951
8,50	10	89	47	35	40	M9923-0850AR	31035954
8,60	10	89	47	35	40	M9923-0860AR	31035955
8,70	10	89	47	35	40	M9923-0870AR	31035956
8,80	10	89	47	35	40	M9923-0880AR	31035957
8,90	10	89	47	35	40	M9923-0890AR	31035958
9,00	10	89	47	35	40	M9923-0900AR	31035959
9,10	10	89	47	35	40	M9923-0910AR	31035960
9,20	10	89	47	35	40	M9923-0920AR	31035961
9,30	10	89	47	35	40	M9923-0930AR	31035962
9,40	10	89	47	35	40	M9923-0940AR	31035963
9,50	10	89	47	35	40	M9923-0950AR	31035964
9,60	10	89	47	35	40	M9923-0960AR	31035965
9,80	10	89	47	35	40	M9923-0980AR	31035967
9,90	10	89	47	35	40	M9923-0990AR	31035968
10,00	10	89	47	35	40	M9923-1000AR	31035969
10,20	12	102	55	40	45	M9923-1020AR	31035971
10,30	12	102	55	40	45	M9923-1030AR	31035972
10,50	12	102	55	40	45	M9923-1050AR	31035974
11,00	12	102	55	40	45	M9923-1100AR	31035979
11,20	12	102	55	40	45	M9923-1120AR	31035981
11,50	12	102	55	40	45	M9923-1150AR	31035984
11,80	12	102	55	40	45	M9923-1180AR	31035987
11,90	12	102	55	40	45	M9923-1190AR	31035988
12,00	12	102	55	40	45	M9923-1200AR	31035989
13,00	14	107	60	43	45	M9923-1300AR	31035993
13,80	14	107	60	43	45	M9923-1380AR	31035995
14,00	14	107	60	43	45	M9923-1400AR	31035996
14,50	16	115	65	45	48	M9923-1450AR	31035998
15,00	16	115	65	45	48	M9923-1500AR	31036000
16,00	16	115	65	45	48	M9923-1600AR	31036004
17,00	18	123	73	51	48	M9923-1700AR	31036007
17,50	18	123	73	51	48	M9923-1750AR	31036008
18,00	18	123	73	51	48	M9923-1800AR	31036010
18,50	20	131	79	55	50	M9923-1850AR	31036011
20,00	20	131	79	55	50	M9923-2000AR	31036016

**MEGA-Speed-Drill-Steel | Vollhartmetall-Spiralbohrer M9923 (3xD), innere Kühlmittelzufuhr****Konfigurierbare Merkmale**

**Durchmesser:**  
Durchmesser in Abstufungen  
von 0,01 mm frei wählbar



**Schaftform:**  
Schaftform HB | HE

**Spezifikation:**

M9923-[Durchmesser][Schaftform]R

**Beispiel:**  
M9923-0431ER

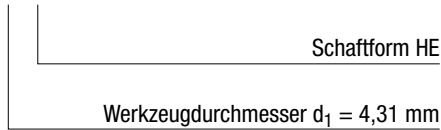
**Abmessungen konfigurierbare Baureihe**

d <sub>1</sub> min.	d <sub>1</sub> max.	d <sub>2</sub> h6	l <sub>1</sub>	l <sub>2</sub>	l <sub>3</sub>	l <sub>4</sub>
3,00	3,70	6	62	20	14	36
3,71	4,70	6	66	24	17	36
4,71	6,00	6	66	28	20	36
6,01	6,80	8	79	34	24	36
6,81	8,00	8	79	41	29	36
8,01	10,00	10	89	47	35	40
10,01	12,00	12	102	55	40	45
12,01	14,00	14	107	60	43	45
14,01	16,00	16	115	65	45	48
16,01	18,00	18	123	73	51	48
18,01	20,00	20	131	79	55	50

Maßangaben in mm.

Schnittwertempfehlung siehe Kapitelende.

Sonderausführungen und andere Beschichtungen auf Anfrage.

# MEGA-Speed-Drill-Steel

Vollhartmetall-Spiralbohrer

M9925 (5xD), innere Kühlmittelzufuhr, Nachfolgeprodukt des MEGA-Speed-Drill-Steel (M9105)

**Ausführung:**

Bohrerdurchmesser: 3,00 - 20,00 mm  
 Bohrungstoleranz:  $\geq$  IT 9  
 Beschichtung: MxP  
 Schneidanzahl: 2  
 Anzahl Führungsfasen: 3  
 Spitzenwinkel: 145°  
 Spiralwinkel: 30°

**Anwendung:**

Für Hochgeschwindigkeitsbearbeitung.

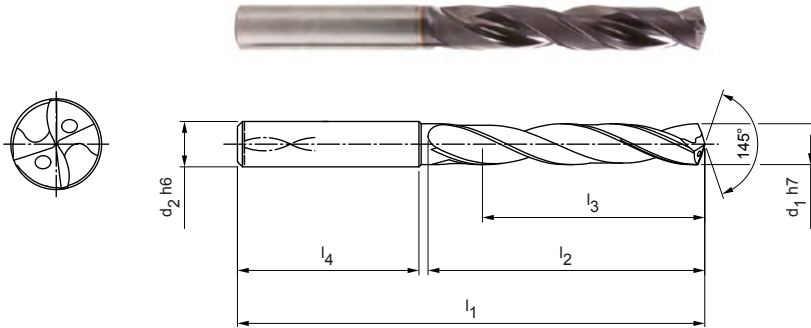

**Lagerhaltige Vorzugsbaureihe in Schaftform HA**

Baumaße						Schaftform HA	
d <sub>1</sub> h7	d <sub>2</sub> h6	l <sub>1</sub>	l <sub>2</sub>	l <sub>3</sub>	l <sub>4</sub>	Spezifikation	Bestell-Nr.
3,00	6	66	28	23	36	M9925-0300AR	30890196
3,10	6	66	28	23	36	M9925-0310AR	30890197
3,20	6	66	28	23	36	M9925-0320AR	30890198
3,30	6	66	28	23	36	M9925-0330AR	30890199
3,40	6	66	28	23	36	M9925-0340AR	30890200
3,50	6	66	28	23	36	M9925-0350AR	30890201
3,70	6	66	28	23	36	M9925-0370AR	30890203
3,80	6	74	36	29	36	M9925-0380AR	30890204
4,00	6	74	36	29	36	M9925-0400AR	30890206
4,20	6	74	36	29	36	M9925-0420AR	30890208
4,30	6	74	36	29	36	M9925-0430AR	30890209
4,50	6	74	36	29	36	M9925-0450AR	30890211
4,65	6	74	36	29	36	M9925-0465AR	31002016
4,70	6	74	36	29	36	M9925-0470AR	30890213
4,80	6	82	44	35	36	M9925-0480AR	30890214
4,90	6	82	44	35	36	M9925-0490AR	30890215
5,00	6	82	44	35	36	M9925-0500AR	30890216
5,10	6	82	44	35	36	M9925-0510AR	30890217
5,20	6	82	44	35	36	M9925-0520AR	30890218
5,30	6	82	44	35	36	M9925-0530AR	30890219
5,40	6	82	44	35	36	M9925-0540AR	30890220
5,50	6	82	44	35	36	M9925-0550AR	30890221
5,55	6	82	44	35	36	M9925-0555AR	31002018
5,60	6	82	44	35	36	M9925-0560AR	30890222
5,70	6	82	44	35	36	M9925-0570AR	30890223
5,80	6	82	44	35	36	M9925-0580AR	30890224
5,90	6	82	44	35	36	M9925-0590AR	30890225
6,00	6	82	44	35	36	M9925-0600AR	30890226
6,10	8	91	53	43	36	M9925-0610AR	30890227
6,20	8	91	53	43	36	M9925-0620AR	30890228
6,30	8	91	53	43	36	M9925-0630AR	30890229
6,50	8	91	53	43	36	M9925-0650AR	30890231
6,70	8	91	53	43	36	M9925-0670AR	30890233
6,80	8	91	53	43	36	M9925-0680AR	30890234



## MEGA-Speed-Drill-Steel | Vollhartmetall-Spiralbohrer M9925 (5xD), innere Kühlmittelzufuhr

Baumaße						Schaftform HA	
d <sub>1</sub> h7	d <sub>2</sub> h6	l <sub>1</sub>	l <sub>2</sub>	l <sub>3</sub>	l <sub>4</sub>	Spezifikation	Bestell-Nr.
6,90	8	91	53	43	36	M9925-0690AR	30890235
7,00	8	91	53	43	36	M9925-0700AR	30890236
7,10	8	91	53	43	36	M9925-0710AR	30890237
7,20	8	91	53	43	36	M9925-0720AR	30890238
7,30	8	91	53	43	36	M9925-0730AR	30890239
7,40	8	91	53	43	36	M9925-0740AR	30890240
7,50	8	91	53	43	36	M9925-0750AR	30890241
7,60	8	91	53	43	36	M9925-0760AR	30890242
7,80	8	91	53	43	36	M9925-0780AR	30890244
8,00	8	91	53	43	36	M9925-0800AR	30890246
8,10	10	103	61	49	40	M9925-0810AR	30890247
8,20	10	103	61	49	40	M9925-0820AR	30890248
8,30	10	103	61	49	40	M9925-0830AR	30890249
8,40	10	103	61	49	40	M9925-0840AR	30890250
8,50	10	103	61	49	40	M9925-0850AR	30890251
8,60	10	103	61	49	40	M9925-0860AR	30890252
8,70	10	89	47	35	40	M9925-0870AR	30890253
8,80	10	103	61	49	40	M9925-0880AR	30890254
9,00	10	103	61	49	40	M9925-0900AR	30890256
9,10	10	103	61	49	40	M9925-0910AR	30890257
9,30	10	103	61	49	40	M9925-0930AR	30890259
9,40	10	103	61	49	40	M9925-0940AR	30890260
9,50	10	103	61	49	40	M9925-0950AR	30890261
9,70	10	103	61	49	40	M9925-0970AR	30890263
9,80	10	103	61	49	40	M9925-0980AR	30890264
9,90	10	103	61	49	40	M9925-0990AR	30890265
10,00	10	103	61	49	40	M9925-1000AR	30890266
10,20	12	118	71	56	45	M9925-1020AR	30890268
10,30	12	118	71	56	45	M9925-1030AR	30890269
10,50	12	118	71	56	45	M9925-1050AR	30890271
11,00	12	118	71	56	45	M9925-1100AR	30890276
11,10	12	118	71	56	45	M9925-1110AR	30890277
11,20	12	118	71	56	45	M9925-1120AR	30890278
11,30	12	118	71	56	45	M9925-1130AR	30890279
11,40	12	118	71	56	45	M9925-1140AR	30890280
11,50	12	118	71	56	45	M9925-1150AR	30890281
11,60	12	118	71	56	45	M9925-1160AR	30890282
11,80	12	118	71	56	45	M9925-1180AR	30890284
11,90	12	118	71	56	45	M9925-1190AR	30890285
12,00	12	118	71	56	45	M9925-1200AR	30890286
12,20	14	124	77	60	45	M9925-1220AR	30890287
12,50	14	124	77	60	45	M9925-1250AR	30890288
12,80	14	124	77	60	45	M9925-1280AR	30890289
13,00	14	124	77	60	45	M9925-1300AR	30890290
13,50	14	124	77	60	45	M9925-1350AR	30890291
13,80	14	124	77	60	45	M9925-1380AR	30890292
14,00	14	124	77	60	45	M9925-1400AR	30890293
14,20	16	133	83	63	48	M9925-1420AR	30890294
14,50	16	133	83	63	48	M9925-1450AR	30890295
15,00	16	133	83	63	48	M9925-1500AR	30890297
15,20	16	133	83	63	48	M9925-1520AR	30890298
15,50	16	133	83	63	48	M9925-1550AR	30890299
16,00	16	133	83	63	48	M9925-1600AR	30890301
16,50	18	143	93	71	48	M9925-1650AR	30890302
17,00	18	143	93	71	48	M9925-1700AR	30890304
17,50	18	143	93	71	48	M9925-1750AR	30890305

Fortsetzung auf nächster Seite.

**MEGA-Speed-Drill-Steel | Vollhartmetall-Spiralbohrer M9925 (5xD), innere Kühlmittelzufuhr**

Baumaße						Schaffform HA	
d <sub>1</sub> h7	d <sub>2</sub> h6	l <sub>1</sub>	l <sub>2</sub>	l <sub>3</sub>	l <sub>4</sub>	Spezifikation	Bestell-Nr.
18,00	18	143	93	71	48	M9925-1800AR	30890307
18,50	20	153	101	77	50	M9925-1850AR	30890308
19,80	20	153	101	77	50	M9925-1980AR	30890312
20,00	20	153	101	77	50	M9925-2000AR	30890313

**Konfigurierbare Merkmale****Durchmesser:**

Durchmesser in Abstufungen  
von 0,01 mm frei wählbar

**Schaffform:**

Schaffform: HB | HE

**Spezifikation:**

M9925-[Durchmesser][Schaffform]R

**Beispiel:**

M9925-0431ER

Schaffform HE

Werkzeugdurchmesser d<sub>1</sub> = 4,31 mm

**Abmessungen konfigurierbare Baureihe**

d <sub>1</sub> min.	d <sub>1</sub> max.	d <sub>2</sub> h6	l <sub>1</sub>	l <sub>2</sub>	l <sub>3</sub>	l <sub>4</sub>
3,00	3,70	6	66	28	23	36
3,71	4,70	6	74	36	29	36
4,71	6,00	6	82	44	35	36
6,01	6,80	8	91	53	43	36
6,81	8,00	8	91	53	43	36
8,01	9,00	10	103	61	49	40
9,01	10,00	10	103	61	49	40
10,01	11,00	12	118	71	56	45
11,01	12,00	12	118	71	56	45
12,01	14,00	14	124	77	60	45
14,01	16,00	16	133	83	63	48
16,01	18,00	18	143	93	71	48
18,01	20,00	20	153	101	77	50

# MEGA-Speed-Drill-Steel

Vollhartmetall-Spiralbohrer

M9928 (8xD), innere Kühlmittelzufuhr, Nachfolgeprodukt des MEGA-Speed-Drill-Steel (M9108)

**Ausführung:**

Bohrerdurchmesser: 3,00 - 20,00 mm  
 Bohrungstoleranz: IT 9 (erreichbar)  
 Beschichtung: MxP  
 Schneidanzahl: 2  
 Anzahl Führungsfasen: 3  
 Spitzenwinkel: 145°  
 Spiralwinkel: 30°

**Anwendung:**

Für Hochgeschwindigkeitsbearbeitung.

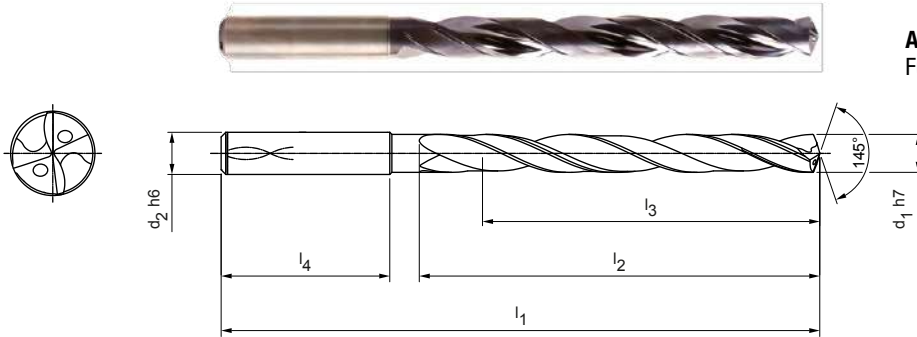

**Lagerhaltige Vorzugsbaureihe in Schaftform HA**

Baumaße						Schaftform HA	
d <sub>1</sub> h7	d <sub>2</sub> h6	l <sub>1</sub>	l <sub>2</sub>	l <sub>3</sub>	l <sub>4</sub>	Spezifikation	Bestell-Nr.
3,00	6	72	34	29	36	M9928-0300AR	31035771
3,10	6	72	34	29	36	M9928-0310AR	31035772
3,20	6	72	34	29	36	M9928-0320AR	31035773
3,30	6	72	34	29	36	M9928-0330AR	31035774
3,40	6	72	34	29	36	M9928-0340AR	31035775
3,50	6	72	34	29	36	M9928-0350AR	31035776
3,70	6	72	34	29	36	M9928-0370AR	31035778
4,00	6	81	43	36	36	M9928-0400AR	31035791
4,10	6	81	43	36	36	M9928-0410AR	31035792
4,20	6	81	43	36	36	M9928-0420AR	31035793
4,30	6	81	43	36	36	M9928-0430AR	31035794
4,50	6	81	43	36	36	M9928-0450AR	31035796
4,65	6	81	43	36	36	M9928-0465AR	31038703
4,80	6	95	57	48	36	M9928-0480AR	31035799
4,90	6	95	57	48	36	M9928-0490AR	31035800
5,00	6	95	57	48	36	M9928-0500AR	31035801
5,10	6	95	57	48	36	M9928-0510AR	31035802
5,20	6	95	57	48	36	M9928-0520AR	31035803
5,40	6	95	57	48	36	M9928-0540AR	31035805
5,50	6	95	57	48	36	M9928-0550AR	31035806
5,55	6	95	57	48	36	M9928-0555AR	31038704
5,60	6	95	57	48	36	M9928-0560AR	31035807
5,80	6	95	57	48	36	M9928-0580AR	31035809
5,90	6	95	57	48	36	M9928-0590AR	31035810
6,00	6	95	57	48	36	M9928-0600AR	31035811
6,10	8	114	76	64	36	M9928-0610AR	31035812
6,20	8	114	76	64	36	M9928-0620AR	31035813
6,50	8	114	76	64	36	M9928-0650AR	31035816
6,80	8	114	76	64	36	M9928-0680AR	31035819
6,90	8	114	76	64	36	M9928-0690AR	31035820
7,00	8	114	76	64	36	M9928-0700AR	31035821
7,50	8	114	76	64	36	M9928-0750AR	31035826
7,80	8	114	76	64	36	M9928-0780AR	31035829
8,00	8	114	76	64	36	M9928-0800AR	31035831
8,10	10	142	95	80	40	M9928-0810AR	31035832

## MEGA-Speed-Drill-Steel | Vollhartmetall-Spiralbohrer M9928 (8xD), innere Kühlmittelzufuhr

Baumaße						Schaftform HA	
d <sub>1</sub> h7	d <sub>2</sub> h6	l <sub>1</sub>	l <sub>2</sub>	l <sub>3</sub>	l <sub>4</sub>	Spezifikation	Bestell-Nr.
8,50	10	142	95	80	40	M9928-0850AR	31035836
9,00	10	142	95	80	40	M9928-0900AR	31035841
9,50	10	142	95	80	40	M9928-0950AR	31035846
9,80	10	142	95	80	40	M9928-0980AR	31035849
10,00	10	142	95	80	40	M9928-1000AR	31035851
10,20	12	162	114	96	45	M9928-1020AR	31035853
10,30	12	162	114	96	45	M9928-1030AR	31035854
10,50	12	162	114	96	45	M9928-1050AR	31035856
11,00	12	162	114	96	45	M9928-1100AR	31035861
11,80	12	162	114	96	45	M9928-1180AR	31035869
12,00	12	162	114	96	45	M9928-1200AR	31035871
12,50	14	178	133	112	45	M9928-1250AR	31035873
13,00	14	178	133	112	45	M9928-1300AR	31035875
13,50	14	178	133	112	45	M9928-1350AR	31035876
14,00	14	178	133	112	45	M9928-1400AR	31035878
15,00	16	203	152	128	48	M9928-1500AR	31035882
15,80	16	203	152	128	48	M9928-1580AR	31035885
16,00	16	203	152	128	48	M9928-1600AR	31035886
19,00	20	243	190	160	50	M9928-1900AR	31035895
19,80	20	243	190	160	50	M9928-1980AR	31035897

## Konfigurierbare Merkmale



**Durchmesser:**  
Durchmesser in Abstufungen  
von 0,01 mm frei wählbar



**Schaftform:**  
Schaftform: HB | HE

**Spezifikation:**

M9928-[Durchmesser][Schaftform]R

**Beispiel:**  
M9928-0431ER

Schaftform HE

Werkzeugdurchmesser d<sub>1</sub> = 4,31 mm

## Abmessungen konfigurierbare Baureihe

d <sub>1</sub> min.	d <sub>1</sub> max.	d <sub>2</sub> h6	l <sub>1</sub>	l <sub>2</sub>	l <sub>3</sub>	l <sub>4</sub>
3,00	3,70	6	72	34	29	36
3,71	4,70	6	81	43	36	36
4,71	6,00	6	95	57	48	36
6,01	6,80	8	114	76	64	36
6,81	8,00	8	114	76	64	36
8,01	9,00	10	142	95	80	40
9,01	10,00	10	142	95	80	40
10,01	11,00	12	162	114	96	45
11,01	12,00	12	162	114	96	45
12,01	14,00	14	178	133	112	45
14,01	16,00	16	203	152	128	48
16,01	18,00	18	222	171	144	48
18,01	20,00	20	243	190	160	50

Maßangaben in mm.

Schnittwertempfehlung siehe Kapitelende.

Sonderausführungen und andere Beschichtungen auf Anfrage.

# MEGA-Speed-Drill-Steel

Vollhartmetall-Spiralbohrer

M9932 (12xD), innere Kühlmittelzufuhr, Nachfolgeprodukt des MEGA-Speed-Drill-Steel (M9112)

**Ausführung:**

Bohrerdurchmesser: 3,00 - 20,00 mm  
 Bohrungstoleranz:  $\geq$  IT 9  
 Beschichtung: MxP  
 Schneidanzahl: 2  
 Anzahl Führungsfasen: 3  
 Spitzenwinkel: 145°  
 Spiralwinkel: 30°

**Anwendung:**

Für Hochgeschwindigkeitsbearbeitung.

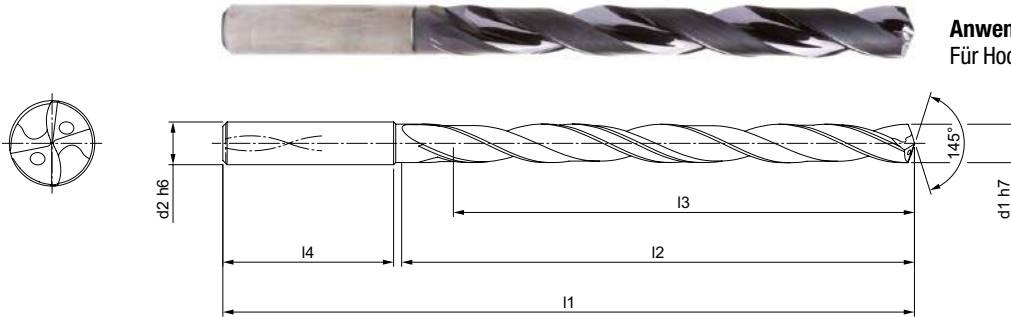

**Lagerhaltige Vorzugsbaureihe in Schaftform HA**

Baumaße						Schaftform HA	
d <sub>1</sub> h7	d <sub>2</sub> h6	l <sub>1</sub>	l <sub>2</sub>	l <sub>3</sub>	l <sub>4</sub>	Spezifikation	Bestell-Nr.
3,00	6	92	54	48	36	M9932-0300AR	31239019
3,20	6	92	54	48	36	M9932-0320AR	31239041
3,30	6	92	54	48	36	M9932-0330AR	31239042
3,40	6	92	54	48	36	M9932-0340AR	31239043
3,50	6	92	54	48	36	M9932-0350AR	31239044
3,70	6	92	54	48	36	M9932-0370AR	31239046
4,00	6	102	64	58	36	M9932-0400AR	31239049
4,10	6	102	64	58	36	M9932-0410AR	31239050
4,20	6	102	64	58	36	M9932-0420AR	31239051
4,30	6	102	64	58	36	M9932-0430AR	31239052
4,50	6	102	64	58	36	M9932-0450AR	31239054
4,80	6	116	78	70	36	M9932-0480AR	31239057
5,00	6	116	78	70	36	M9932-0500AR	31239059
5,10	6	116	78	70	36	M9932-0510AR	31239060
5,20	6	116	78	70	36	M9932-0520AR	31239061
5,40	6	116	78	70	36	M9932-0540AR	31239063
5,50	6	116	78	70	36	M9932-0550AR	31239064
5,80	6	116	78	70	36	M9932-0580AR	31239067
6,00	6	116	78	70	36	M9932-0600AR	31239069
6,10	8	146	108	94	36	M9932-0610AR	31239070
6,50	8	146	108	94	36	M9932-0650AR	31239074
6,80	8	146	108	94	36	M9932-0680AR	31239077
7,00	8	146	108	94	36	M9932-0700AR	31239079
7,50	8	146	108	94	36	M9932-0750AR	31239084
7,80	8	146	108	94	36	M9932-0780AR	31239087
8,00	8	146	108	94	36	M9932-0800AR	31239089
8,50	10	162	120	110	40	M9932-0850AR	31239094
9,00	10	162	120	110	40	M9932-0900AR	31239099
9,50	10	162	120	110	40	M9932-0950AR	31239104
9,80	10	162	120	110	40	M9932-0980AR	31239107
10,00	10	162	120	110	40	M9932-1000AR	31239109
10,20	12	204	156	142	45	M9932-1020AR	31239111
10,50	12	204	156	142	45	M9932-1050AR	31239114
11,00	12	204	156	142	45	M9932-1100AR	31239119
11,80	12	204	156	142	45	M9932-1180AR	31239127

**MEGA-Speed-Drill-Steel | Vollhartmetall-Spiralbohrer M9932 (12xD), innere Kühlmittelzufuhr**

Baumaße						Schaftform HA	
d <sub>1</sub> h7	d <sub>2</sub> h6	l <sub>1</sub>	l <sub>2</sub>	l <sub>3</sub>	l <sub>4</sub>	Spezifikation	Bestell-Nr.
12,00	12	204	156	142	45	M9932-1200AR	31239129
12,50	14	230	182	166	45	M9932-1250AR	31239131
13,00	14	230	182	166	45	M9932-1300AR	31239133
13,50	14	230	182	166	45	M9932-1350AR	31239134
14,00	14	230	182	166	45	M9932-1400AR	31239136
15,00	16	260	208	192	48	M9932-1500AR	31239139
16,00	16	260	208	192	48	M9932-1600AR	31239144

**Konfigurierbare Merkmale****Durchmesser:**

Durchmesser in Abstufungen  
von 0,01 mm frei wählbar

**Schaftform:**

Schaftform: HB | HE

**Spezifikation:**

M9932-[Durchmesser][Schaftform]R

**Beispiel:**  
M9932-0431ER

Schaftform HE

Werkzeughdurchmesser d<sub>1</sub> = 4,31 mm

**Abmessungen konfigurierbare Baureihe**

d <sub>1</sub> min.	d <sub>1</sub> max.	d <sub>2</sub> h6	l <sub>1</sub>	l <sub>2</sub>	l <sub>3</sub>	l <sub>4</sub>
3,00	3,70	6	92	54	48	36
3,71	4,70	6	102	64	58	36
4,71	6,00	6	116	78	70	36
6,01	6,80	8	146	108	94	36
6,81	8,00	8	146	108	94	36
8,01	9,00	10	162	120	110	40
9,01	10,00	10	162	120	110	40
10,01	11,00	12	204	156	142	45
11,01	12,00	12	204	156	142	45
12,01	14,00	14	230	182	166	45
14,01	16,00	16	260	208	192	48
16,01	18,00	18	285	234	216	48
18,01	20,00	20	310	258	240	50

Maßangaben in mm.

Schnittwertempfehlung siehe Kapitelende.

Sonderausführungen und andere Beschichtungen auf Anfrage.

# MEGA-180°-Drill

Vollhartmetall-Spiralbohrer  
M9183 (3xD), innere Kühlmittelzufuhr

**Ausführung:**

Bohrerdurchmesser: 3,00 - 20,00 mm  
Bohrungstoleranz:  $\geq$  IT 9  
Beschichtung: MxF  
Schneidenanzahl: 2  
Anzahl Führungsfasen: 4  
Spitzenwinkel: 180°  
Spiralwinkel: 30°

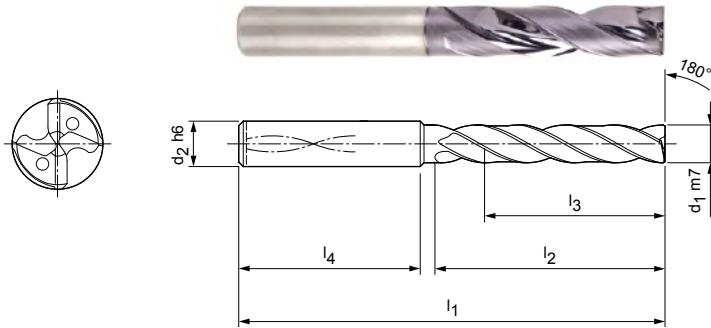

**Lagerhaltige Vorzugsbaureihe in Schaftform HA**

Baumaße						Schaftform HA	
d <sub>1</sub> m7	d <sub>2</sub> h6	l <sub>1</sub>	l <sub>2</sub>	l <sub>3</sub>	l <sub>4</sub>	Spezifikation	Bestell-Nr.
3,00	6	62	20	14	36	M9183-0300AE	30286325
3,10	6	62	20	14	36	M9183-0310AE	30286443
3,20	6	62	20	14	36	M9183-0320AE	30286326
3,30	6	62	20	14	36	M9183-0330AE	30286327
3,40	6	62	20	14	36	M9183-0340AE	30286328
3,50	6	62	20	14	36	M9183-0350AE	30286329
3,60	6	62	20	14	36	M9183-0360AE	30286444
3,70	6	62	20	14	36	M9183-0370AE	30286330
3,80	6	66	24	17	36	M9183-0380AE	30286331
3,90	6	66	24	17	36	M9183-0390AE	30286332
4,00	6	66	24	17	36	M9183-0400AE	30286333
4,10	6	66	24	17	36	M9183-0410AE	30286445
4,20	6	66	24	17	36	M9183-0420AE	30286334
4,30	6	66	24	17	36	M9183-0430AE	30286335
4,40	6	66	24	17	36	M9183-0440AE	30286446
4,50	6	66	24	17	36	M9183-0450AE	30286336
4,60	6	66	24	17	36	M9183-0460AE	30286447
4,65	6	66	24	17	36	M9183-0465AE	30286337
4,70	6	66	24	17	36	M9183-0470AE	30286448
4,80	6	66	28	20	36	M9183-0480AE	30286338
4,90	6	66	28	20	36	M9183-0490AE	30286449
5,00	6	66	28	20	36	M9183-0500AE	30286339
5,10	6	66	28	20	36	M9183-0510AE	30286340
5,20	6	66	28	20	36	M9183-0520AE	30286341
5,30	6	66	28	20	36	M9183-0530AE	30286342
5,40	6	66	28	20	36	M9183-0540AE	30286450
5,50	6	66	28	20	36	M9183-0550AE	30286343
5,55	6	66	28	20	36	M9183-0555AE	30286344
5,60	6	66	28	20	36	M9183-0560AE	30286345
5,70	6	66	28	20	36	M9183-0570AE	30286451
5,80	6	66	28	20	36	M9183-0580AE	30286346
5,90	6	66	28	20	36	M9183-0590AE	30286452
6,00	6	66	28	20	36	M9183-0600AE	30286347
6,10	8	79	34	24	36	M9183-0610AE	30286348
6,20	8	79	34	24	36	M9183-0620AE	30286349

## MEGA-180°-Drill | Vollhartmetall-Spiralbohrer M9183 (3xD), innere Kühlmittelzufuhr

Baumaße						Schaffform HA	
d <sub>1</sub> m7	d <sub>2</sub> h6	l <sub>1</sub>	l <sub>2</sub>	l <sub>3</sub>	l <sub>4</sub>	Spezifikation	Bestell-Nr.
6,30	8	79	34	24	36	M9183-0630AE	30286350
6,40	8	79	34	24	36	M9183-0640AE	30286453
6,50	8	79	34	24	36	M9183-0650AE	30286351
6,60	8	79	34	24	36	M9183-0660AE	30286352
6,70	8	79	34	24	36	M9183-0670AE	30286454
6,80	8	79	34	24	36	M9183-0680AE	30286353
6,90	8	79	34	24	36	M9183-0690AE	30286354
7,00	8	79	34	24	36	M9183-0700AE	30286355
7,10	8	79	41	29	36	M9183-0710AE	30286455
7,20	8	79	41	29	36	M9183-0720AE	30286456
7,30	8	79	41	29	36	M9183-0730AE	30286457
7,40	8	79	41	29	36	M9183-0740AE	30286356
7,50	8	79	41	29	36	M9183-0750AE	30286357
7,60	8	79	41	29	36	M9183-0760AE	30286458
7,70	8	79	41	29	36	M9183-0770AE	30286459
7,80	8	79	41	29	36	M9183-0780AE	30286358
7,90	8	79	41	29	36	M9183-0790AE	30286359
8,00	8	79	41	29	36	M9183-0800AE	30286360
8,10	10	89	47	35	40	M9183-0810AE	30286361
8,20	10	89	47	35	40	M9183-0820AE	30286362
8,30	10	89	47	35	40	M9183-0830AE	30286461
8,40	10	89	47	35	40	M9183-0840AE	30286462
8,50	10	89	47	35	40	M9183-0850AE	30286363
8,60	10	89	47	35	40	M9183-0860AE	30286364
8,70	10	89	47	35	40	M9183-0870AE	30286365
8,80	10	89	47	35	40	M9183-0880AE	30286366
8,90	10	89	47	35	40	M9183-0890AE	30286463
9,00	10	89	47	35	40	M9183-0900AE	30286367
9,10	10	89	47	35	40	M9183-0910AE	30286464
9,20	10	89	47	35	40	M9183-0920AE	30286465
9,30	10	89	47	35	40	M9183-0930AE	30286368
9,40	10	89	47	35	40	M9183-0940AE	30286466
9,50	10	89	47	35	40	M9183-0950AE	30286369
9,60	10	89	47	35	40	M9183-0960AE	30286467
9,70	10	89	47	35	40	M9183-0970AE	30286468
9,80	10	89	47	35	40	M9183-0980AE	30286370
9,90	10	89	47	35	40	M9183-0990AE	30286469
10,00	10	89	47	35	40	M9183-1000AE	30286371
10,10	12	100	53	38	45	M9183-1010AE	30286372
10,20	12	100	53	38	45	M9183-1020AE	30286373
10,30	12	100	53	38	45	M9183-1030AE	30286374
10,40	12	100	53	38	45	M9183-1040AE	30286470
10,50	12	100	53	38	45	M9183-1050AE	30286375
10,60	12	100	53	38	45	M9183-1060AE	30286471
10,70	12	100	53	38	45	M9183-1070AE	30286472
10,80	12	100	53	38	45	M9183-1080AE	30286473
11,00	12	100	53	38	45	M9183-1100AE	30286376
11,10	12	100	53	38	45	M9183-1110AE	30286475
11,20	12	100	53	38	45	M9183-1120AE	30286377
11,30	12	100	53	38	45	M9183-1130AE	30286476
11,40	12	100	53	38	45	M9183-1140AE	30286477
11,50	12	100	53	38	45	M9183-1150AE	30286378
11,60	12	100	53	38	45	M9183-1160AE	30286478
11,70	12	100	53	38	45	M9183-1170AE	30286479
11,80	12	100	53	38	45	M9183-1180AE	30286379
11,90	12	100	53	38	45	M9183-1190AE	30286480
12,00	12	100	53	38	45	M9183-1200AE	30286380



## MEGA-180°-Drill | Vollhartmetall-Spiralbohrer M9183 (3xD), innere Kühlmittelzufuhr

Baumaße						Schaffform HA	
d <sub>1</sub> m7	d <sub>2</sub> h6	l <sub>1</sub>	l <sub>2</sub>	l <sub>3</sub>	l <sub>4</sub>	Spezifikation	Bestell-Nr.
12,50	14	105	58	41	45	M9183-1250AE	30286381
12,70	14	105	58	41	45	M9183-1270AE	30595739
12,80	14	105	58	41	45	M9183-1280AE	30286481
13,00	14	105	58	41	45	M9183-1300AE	30286382
13,50	14	105	58	41	45	M9183-1350AE	30286383
13,80	14	105	58	41	45	M9183-1380AE	30286482
14,00	14	105	58	41	45	M9183-1400AE	30286384
14,50	16	113	63	43	48	M9183-1450AE	30286385
14,80	16	113	63	43	48	M9183-1480AE	30286483
15,00	16	113	63	43	48	M9183-1500AE	30286386
15,50	16	113	63	43	48	M9183-1550AE	30286484
15,80	16	113	63	43	48	M9183-1580AE	30286485
16,00	16	113	63	43	48	M9183-1600AE	30286387
16,50	18	121	71	49	48	M9183-1650AE	30286486
16,80	18	121	71	49	48	M9183-1680AE	30286487
17,00	18	121	71	49	48	M9183-1700AE	30286388
17,50	18	121	71	49	48	M9183-1750AE	30286389
18,00	18	121	71	49	48	M9183-1800AE	30286490
18,50	20	129	77	53	50	M9183-1850AE	30286491
18,80	20	129	77	53	50	M9183-1880AE	30286492
19,00	20	129	77	53	50	M9183-1900AE	30286493
19,50	20	129	77	53	50	M9183-1950AE	30286494
20,00	20	129	77	53	50	M9183-2000AE	30286496

## Konfigurierbare Merkmale



**Durchmesser:**  
Durchmesser in Abstufungen  
von 0,01 mm frei wählbar



**Schaffform:**  
Schaffform: HB | HE

**Spezifikation:**

M9183-[Durchmesser][Schaffform]E

**Beispiel:**  
M9183-0431EE

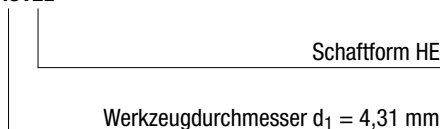

## Abmessungen konfigurierbare Baureihe

d <sub>1</sub> min.	d <sub>1</sub> max.	d <sub>2</sub> h6	l <sub>1</sub>	l <sub>2</sub>	l <sub>3</sub>	l <sub>4</sub>
3,00	3,70	6	62	20	14	36
3,71	4,70	6	66	24	17	36
4,71	6,00	6	66	28	20	36
6,01	6,80	8	79	34	24	36
6,81	8,00	8	79	41	29	36
8,01	10,00	10	89	47	35	40
10,01	12,00	12	100	53	38	45
12,01	14,00	14	105	58	41	45
14,01	16,00	16	113	63	43	48
16,01	18,00	18	121	71	49	48
18,01	20,00	20	129	77	53	50

Maßangaben in mm.

Schnittwertempfehlung siehe Kapitelende.

Sonderausführungen und andere Beschichtungen auf Anfrage.

# MEGA-180°-Drill

Vollhartmetall-Spiralbohrer  
M9185 (5xD), innere Kühlmittelzufuhr

**Ausführung:**

Bohrerdurchmesser: 3,00 - 20,00 mm  
Bohrungstoleranz:  $\geq$  IT 9  
Beschichtung: MxF  
Schneidenanzahl: 2  
Anzahl Führungsfasen: 4  
Spitzenwinkel: 180°  
Spiralwinkel: 30°

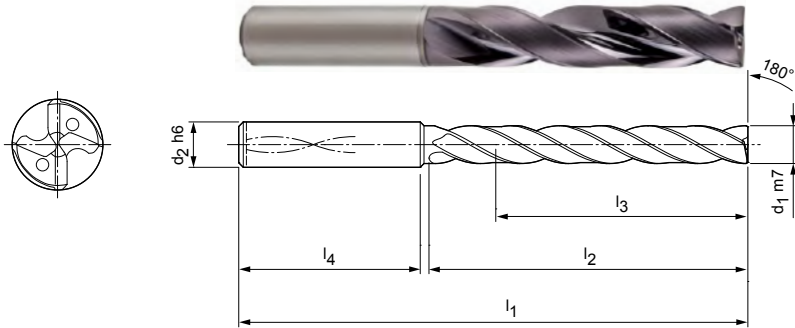

**Lagerhaltige Vorzugsbaureihe in Schaftform HA**

Baumaße						Schaftform HA	
d <sub>1</sub> m7	d <sub>2</sub> h6	l <sub>1</sub>	l <sub>2</sub>	l <sub>3</sub>	l <sub>4</sub>	Spezifikation	Bestell-Nr.
3,00	6	66	28	23	36	M9185-0300AE	30286260
3,10	6	66	28	23	36	M9185-0310AE	30286390
3,20	6	66	28	23	36	M9185-0320AE	30286261
3,30	6	66	28	23	36	M9185-0330AE	30286262
3,40	6	66	28	23	36	M9185-0340AE	30286263
3,50	6	66	28	23	36	M9185-0350AE	30286264
3,60	6	66	28	23	36	M9185-0360AE	30286391
3,70	6	66	28	23	36	M9185-0370AE	30286265
3,80	6	74	36	29	36	M9185-0380AE	30286266
3,90	6	74	36	29	36	M9185-0390AE	30286267
4,00	6	74	36	29	36	M9185-0400AE	30286268
4,10	6	74	36	29	36	M9185-0410AE	30286392
4,20	6	74	36	29	36	M9185-0420AE	30286269
4,30	6	74	36	29	36	M9185-0430AE	30286270
4,40	6	74	36	29	36	M9185-0440AE	30286393
4,50	6	74	36	29	36	M9185-0450AE	30286271
4,60	6	74	36	29	36	M9185-0460AE	30286394
4,80	6	82	44	35	36	M9185-0480AE	30286273
4,90	6	82	44	35	36	M9185-0490AE	30286396
5,00	6	82	44	35	36	M9185-0500AE	30286274
5,10	6	82	44	35	36	M9185-0510AE	30286275
5,20	6	82	44	35	36	M9185-0520AE	30286276
5,30	6	82	44	35	36	M9185-0530AE	30286277
5,40	6	82	44	35	36	M9185-0540AE	30286397
5,50	6	82	44	35	36	M9185-0550AE	30286278
5,55	6	82	44	35	36	M9185-0555AE	30286279
5,60	6	82	44	35	36	M9185-0560AE	30286280
5,70	6	82	44	35	36	M9185-0570AE	30286398
5,80	6	82	44	35	36	M9185-0580AE	30286281
5,90	6	82	44	35	36	M9185-0590AE	30286399
6,00	6	82	44	35	36	M9185-0600AE	30286282
6,10	8	91	53	43	36	M9185-0610AE	30286283
6,20	8	91	53	43	36	M9185-0620AE	30286284
6,30	8	91	53	43	36	M9185-0630AE	30286285
6,40	8	91	53	43	36	M9185-0640AE	30286400

**MEGA-180°-Drill | Vollhartmetall-Spiralbohrer M9185 (5xD), innere Kühlmittelzufuhr**

Baumaße						Schaffform HA	
d <sub>1</sub> m7	d <sub>2</sub> h6	l <sub>1</sub>	l <sub>2</sub>	l <sub>3</sub>	l <sub>4</sub>	Spezifikation	Bestell-Nr.
6,50	8	91	53	43	36	M9185-0650AE	30286286
6,60	8	91	53	43	36	M9185-0660AE	30286287
6,70	8	91	53	43	36	M9185-0670AE	30286401
6,80	8	91	53	43	36	M9185-0680AE	30286288
6,90	8	91	53	43	36	M9185-0690AE	30286289
7,00	8	91	53	43	36	M9185-0700AE	30286290
7,10	8	91	53	43	36	M9185-0710AE	30286402
7,20	8	91	53	43	36	M9185-0720AE	30286403
7,30	8	91	53	43	36	M9185-0730AE	30286404
7,40	8	91	53	43	36	M9185-0740AE	30286291
7,50	8	91	53	43	36	M9185-0750AE	30286292
7,60	8	91	53	43	36	M9185-0760AE	30286405
7,80	8	91	53	43	36	M9185-0780AE	30286293
7,90	8	91	53	43	36	M9185-0790AE	30286294
8,00	8	91	53	43	36	M9185-0800AE	30286295
8,10	10	103	61	49	40	M9185-0810AE	30286296
8,20	10	103	61	49	40	M9185-0820AE	30286297
8,30	10	103	61	49	40	M9185-0830AE	30286407
8,40	10	103	61	49	40	M9185-0840AE	30286408
8,50	10	103	61	49	40	M9185-0850AE	30286298
8,60	10	103	61	49	40	M9185-0860AE	30286299
8,70	10	103	61	49	40	M9185-0870AE	30286300
8,80	10	103	61	49	40	M9185-0880AE	30286301
8,90	10	103	61	49	40	M9185-0890AE	30286409
9,00	10	103	61	49	40	M9185-0900AE	30286302
9,10	10	103	61	49	40	M9185-0910AE	30286410
9,20	10	103	61	49	40	M9185-0920AE	30286411
9,30	10	103	61	49	40	M9185-0930AE	30286303
9,40	10	103	61	49	40	M9185-0940AE	30286412
9,50	10	103	61	49	40	M9185-0950AE	30286304
9,60	10	103	61	49	40	M9185-0960AE	30286413
9,70	10	103	61	49	40	M9185-0970AE	30286414
9,80	10	103	61	49	40	M9185-0980AE	30286305
9,90	10	103	61	49	40	M9185-0990AE	30286415
10,00	10	103	61	49	40	M9185-1000AE	30286306
10,10	12	116	69	54	45	M9185-1010AE	30286307
10,20	12	116	69	54	45	M9185-1020AE	30286308
10,30	12	116	69	54	45	M9185-1030AE	30286309
10,40	12	116	69	54	45	M9185-1040AE	30286416
10,50	12	116	69	54	45	M9185-1050AE	30286310
10,60	12	116	69	54	45	M9185-1060AE	30286417
10,65	12	116	69	54	45	M9185-1065AE	31199458
10,80	12	116	69	54	45	M9185-1080AE	30286419
11,00	12	116	69	54	45	M9185-1100AE	30286311
11,20	12	116	69	54	45	M9185-1120AE	30286312
11,50	12	116	69	54	45	M9185-1150AE	30286313
11,60	12	116	69	54	45	M9185-1160AE	30286424
11,70	12	116	69	54	45	M9185-1170AE	30286425
11,80	12	116	69	54	45	M9185-1180AE	30286314
12,00	12	116	69	54	45	M9185-1200AE	30286315
12,50	14	122	75	58	45	M9185-1250AE	30286316
12,80	14	122	75	58	45	M9185-1280AE	30286427
13,00	14	122	75	58	45	M9185-1300AE	30286317
13,50	14	122	75	58	45	M9185-1350AE	30286318
13,80	14	122	75	58	45	M9185-1380AE	30286428
14,00	14	122	75	58	45	M9185-1400AE	30286319
14,50	16	131	81	61	48	M9185-1450AE	30286320

Fortsetzung auf nächster Seite.

## MEGA-180°-Drill | Vollhartmetall-Spiralbohrer M9185 (5xD), innere Kühlmittelzufuhr

Baumaße						Schaffform HA	
d <sub>1</sub> m7	d <sub>2</sub> h6	l <sub>1</sub>	l <sub>2</sub>	l <sub>3</sub>	l <sub>4</sub>	Spezifikation	Bestell-Nr.
14,80	16	131	81	61	48	M9185-1480AE	30286430
15,00	16	131	81	61	48	M9185-1500AE	30286321
15,50	16	131	81	61	48	M9185-1550AE	30286431
15,80	16	131	81	61	48	M9185-1580AE	30286432
16,00	16	131	81	61	48	M9185-1600AE	30286322
16,50	18	141	91	69	48	M9185-1650AE	30286433
17,00	18	141	91	69	48	M9185-1700AE	30286323
17,50	18	141	91	69	48	M9185-1750AE	30286324
17,80	18	141	91	69	48	M9185-1780AE	30286435
18,00	18	141	91	69	48	M9185-1800AE	30286436
18,50	20	151	99	75	50	M9185-1850AE	30286437
19,00	20	151	99	75	50	M9185-1900AE	30286439
19,80	20	151	99	75	50	M9185-1980AE	30286441
20,00	20	151	99	75	50	M9185-2000AE	30286442

## Konfigurierbare Merkmale



**Durchmesser:**  
Durchmesser in Abstufungen  
von 0,01 mm frei wählbar



**Schaffform:**  
Schaffform: HB | HE

**Spezifikation:**

M9185-[Durchmesser][Schaffform]E

## Abmessungen konfigurierbare Baureihe

d <sub>1</sub> min.	d <sub>1</sub> max.	d <sub>2</sub> h6	l <sub>1</sub>	l <sub>2</sub>	l <sub>3</sub>	l <sub>4</sub>
3,00	3,70	6	66	28	23	36
3,71	4,70	6	74	36	29	36
4,71	6,00	6	82	44	35	36
6,01	8,00	8	91	53	43	36
8,01	10,00	10	103	61	49	40
10,01	12,00	12	116	69	54	45
12,01	14,00	14	122	75	58	45
14,01	16,00	16	131	81	61	48
16,01	18,00	18	141	91	69	48
18,01	20,00	20	151	99	75	50

**Beispiel:**  
M9185-0431EE

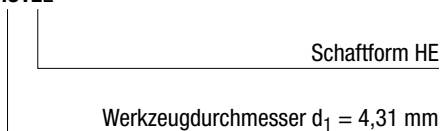

Maßangaben in mm.

Schnittwertempfehlung siehe Kapitelende.

Sonderausführungen und andere Beschichtungen auf Anfrage.

# ECU-Drill-Steel

Vollhartmetall-Spiralbohrer  
M6103 (3xD), innere Kühlmittelzufuhr

**Ausführung:**  
Bohrerdurchmesser: 3,00 - 20,00 mm  
Bohrungstoleranz:  $\geq$  IT 9  
Beschichtung: Mx4  
Schneidenanzahl: 2  
Spitzenwinkel: 140°  
Spiralwinkel: 30°

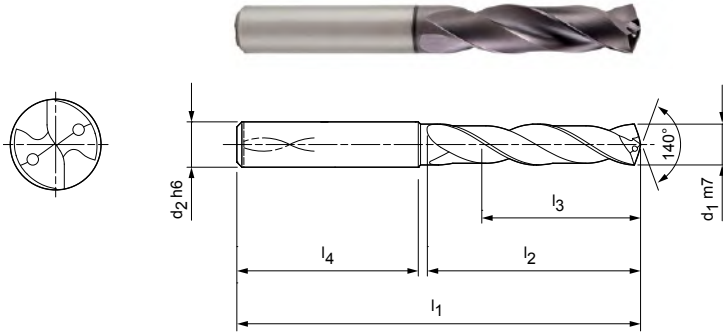

## Lagerhaltige Vorzugsbaureihe in Schaftform HA

Baumaße						Schaftform HA	
d <sub>1</sub> m7	d <sub>2</sub> h6	l <sub>1</sub>	l <sub>2</sub>	l <sub>3</sub>	l <sub>4</sub>	Spezifikation	Bestell-Nr.
3,00	6	62	20	14	36	M6103-0300AW	30245710
3,10	6	62	20	14	36	M6103-0310AW	30245712
3,20	6	62	20	14	36	M6103-0320AW	30245714
3,30	6	62	20	14	36	M6103-0330AW	30245717
3,40	6	62	20	14	36	M6103-0340AW	30245719
3,50	6	62	20	14	36	M6103-0350AW	30245721
3,70*	6	62	20	14	36	M6103-0370AW	30245725
3,80	6	66	24	17	36	M6103-0380AW	30245727
3,90	6	66	24	17	36	M6103-0390AW	30245729
4,00	6	66	24	17	36	M6103-0400AW	30245731
4,10	6	66	24	17	36	M6103-0410AW	30245733
4,20	6	66	24	17	36	M6103-0420AW	30245735
4,30	6	66	24	17	36	M6103-0430AW	30245738
4,40	6	66	24	17	36	M6103-0440AW	30245740
4,50	6	66	24	17	36	M6103-0450AW	30245742
4,60	6	66	24	17	36	M6103-0460AW	30245744
4,65*	6	66	24	17	36	M6103-0465AW	30245746
4,70	6	66	24	17	36	M6103-0470AW	30245748
4,80	6	66	28	20	36	M6103-0480AW	30245750
4,90	6	66	28	20	36	M6103-0490AW	30245752
5,00	6	66	28	20	36	M6103-0500AW	30245755
5,10	6	66	28	20	36	M6103-0510AW	30245758
5,20	6	66	28	20	36	M6103-0520AW	30245760
5,30	6	66	28	20	36	M6103-0530AW	30245762
5,40	6	66	28	20	36	M6103-0540AW	30245764
5,50	6	66	28	20	36	M6103-0550AW	30245766
5,55*	6	66	28	20	36	M6103-0555AW	30245769
5,60	6	66	28	20	36	M6103-0560AW	30245770
5,80	6	66	28	20	36	M6103-0580AW	30245775
5,90	6	66	28	20	36	M6103-0590AW	30245777
6,00	6	66	28	20	36	M6103-0600AW	30245779
6,10	8	79	34	24	36	M6103-0610AW	30245781
6,20	8	79	34	24	36	M6103-0620AW	30245783
6,30	8	79	34	24	36	M6103-0630AW	30245785
6,40	8	79	34	24	36	M6103-0640AW	30245787

## ECU-Drill-Steel | Vollhartmetall-Spiralbohrer M6103 (3xD), innere Kühlmittelzufuhr

Baumaße						Schaftform HA	
d <sub>1</sub> m7	d <sub>2</sub> h6	l <sub>1</sub>	l <sub>2</sub>	l <sub>3</sub>	l <sub>4</sub>	Spezifikation	Bestell-Nr.
6,50	8	79	34	24	36	M6103-0650AW	30245789
6,60	8	79	34	24	36	M6103-0660AW	30245791
6,70	8	79	34	24	36	M6103-0670AW	30245793
6,80	8	79	34	24	36	M6103-0680AW	30245795
6,90	8	79	34	24	36	M6103-0690AW	30245797
7,00	8	79	34	24	36	M6103-0700AW	30245799
7,10	8	79	41	29	36	M6103-0710AW	30245801
7,20	8	79	41	29	36	M6103-0720AW	30245803
7,40	8	79	41	29	36	M6103-0740AW	30245807
7,45*	8	79	41	29	36	M6103-0745AW	30245809
7,50	8	79	41	29	36	M6103-0750AW	30245810
7,70	8	79	41	29	36	M6103-0770AW	30245814
7,80	8	79	41	29	36	M6103-0780AW	30245816
7,90	8	79	41	29	36	M6103-0790AW	30245818
8,00	8	79	41	29	36	M6103-0800AW	30245820
8,10	10	89	47	35	40	M6103-0810AW	30245822
8,20	10	89	47	35	40	M6103-0820AW	30245824
8,30	10	89	47	35	40	M6103-0830AW	30245826
8,40	10	89	47	35	40	M6103-0840AW	30245828
8,50	10	89	47	35	40	M6103-0850AW	30245830
8,60	10	89	47	35	40	M6103-0860AW	30245832
8,70	10	89	47	35	40	M6103-0870AW	30245834
8,80	10	89	47	35	40	M6103-0880AW	30245836
8,90	10	89	47	35	40	M6103-0890AW	30245838
9,00	10	89	47	35	40	M6103-0900AW	30245840
9,10	10	89	47	35	40	M6103-0910AW	30245842
9,20	10	89	47	35	40	M6103-0920AW	30245844
9,30*	10	89	47	35	40	M6103-0930AW	30245846
9,35	10	89	47	35	40	M6103-0935AW	30245848
9,40	10	89	47	35	40	M6103-0940AW	30245849
9,50	10	89	47	35	40	M6103-0950AW	30245851
9,60	10	89	47	35	40	M6103-0960AW	30245853
9,80	10	89	47	35	40	M6103-0980AW	30245857
9,90	10	89	47	35	40	M6103-0990AW	30245859
10,00	10	89	47	35	40	M6103-1000AW	30245861
10,10	12	102	55	40	45	M6103-1010AW	30245863
10,20	12	102	55	40	45	M6103-1020AW	30245865
10,30	12	102	55	40	45	M6103-1030AW	30245867
10,40	12	102	55	40	45	M6103-1040AW	30245869
10,50	12	102	55	40	45	M6103-1050AW	30245871
10,60	12	102	55	40	45	M6103-1060AW	30245874
10,70	12	102	55	40	45	M6103-1070AW	30245876
10,80	12	102	55	40	45	M6103-1080AW	30245880
10,90	12	102	55	40	45	M6103-1090AW	30245882
11,00	12	102	55	40	45	M6103-1100AW	30245884
11,10	12	102	55	40	45	M6103-1110AW	30245886
11,20*	12	102	55	40	45	M6103-1120AW	30245888
11,40	12	102	55	40	45	M6103-1140AW	30245892
11,50	12	102	55	40	45	M6103-1150AW	30245894
11,70	12	102	55	40	45	M6103-1170AW	30245898
11,80	12	102	55	40	45	M6103-1180AW	30245900
12,00	12	102	55	40	45	M6103-1200AW	30245904
12,25	14	107	60	43	45	M6103-1225AW	30245906
12,50	14	107	60	43	45	M6103-1250AW	30245908
12,70	14	107	60	43	45	M6103-1270AW	30245910
12,80	14	107	60	43	45	M6103-1280AW	30245912
12,90	14	107	60	43	45	M6103-1290AW	30245914

## ECU-Drill-Steel | Vollhartmetall-Spiralbohrer M6103 (3xD), innere Kühlmittelzufuhr

Baumaße						Schaftform HA	
d <sub>1</sub> m7	d <sub>2</sub> h6	l <sub>1</sub>	l <sub>2</sub>	l <sub>3</sub>	l <sub>4</sub>	Spezifikation	Bestell-Nr.
13,00	14	107	60	43	45	M6103-1300AW	30245916
13,10	14	107	60	43	45	M6103-1310AW	30245918
13,20	14	107	60	43	45	M6103-1320AW	30245920
13,50	14	107	60	43	45	M6103-1350AW	30245922
13,80	14	107	60	43	45	M6103-1380AW	30245926
14,00	14	107	60	43	45	M6103-1400AW	30245928
14,20	16	115	65	45	48	M6103-1420AW	30245930
14,50	16	115	65	45	48	M6103-1450AW	30245932
14,80	16	115	65	45	48	M6103-1480AW	30245934
15,00	16	115	65	45	48	M6103-1500AW	30245936
15,10	16	115	65	45	48	M6103-1510AW	30245938
15,25	16	115	65	45	48	M6103-1525AW	30245940
15,30	16	115	65	45	48	M6103-1530AW	30245942
15,50	16	115	65	45	48	M6103-1550AW	30245944
15,80	16	115	65	45	48	M6103-1580AW	30245947
16,00	16	115	65	45	48	M6103-1600AW	30245949
16,50	18	123	73	51	48	M6103-1650AW	30245951
16,80	18	123	73	51	48	M6103-1680AW	30245953
17,00	18	123	73	51	48	M6103-1700AW	30245956
17,50	18	123	73	51	48	M6103-1750AW	30245958
17,80	18	123	73	51	48	M6103-1780AW	30245961
18,00	18	123	73	51	48	M6103-1800AW	30245963
18,50	20	131	79	55	50	M6103-1850AW	30245965
19,00	20	131	79	55	50	M6103-1900AW	30245970
19,80	20	131	79	55	50	M6103-1980AW	30245975
20,00	20	131	79	55	50	M6103-2000AW	30245977

## Konfigurierbare Merkmale



**Schaftform:**  
Schaftform: HB | HE



**Spezifikation:**  
M6103-1550[Schaftform]W

Beispiel:  
M6103-1550EW

Schaftform HE

Maßangaben in mm.

\* Speziell zur Vorfertigung der Kernlöcher für Gewindeformer geeignet.

Schnittwertempfehlung siehe Kapitelende.

Sonderausführungen und andere Beschichtungen auf Anfrage.

# ECU-Drill-Steel

Vollhartmetall-Spiralbohrer  
M6003 (3xD), äußere Kühlmittelzufuhr

**Ausführung:**

Bohrerdurchmesser: 3,00 - 20,00 mm  
Bohrungstoleranz:  $\geq$  IT 9  
Beschichtung: Mx4  
Schneidenanzahl: 2  
Spitzenwinkel: 140°  
Spiralwinkel: 30°

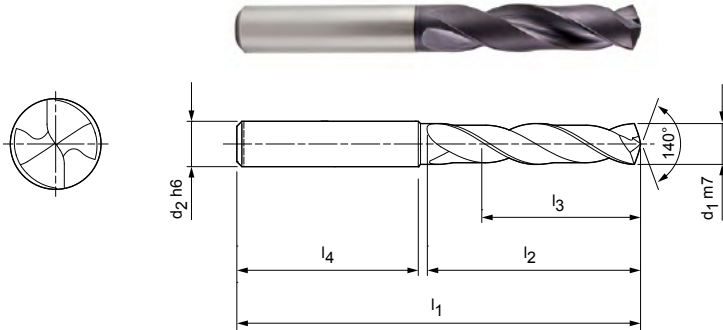

**Lagerhaltige Vorzugsbaureihe in Schaftform HA**

Baumaße						Schaftform HA	
d <sub>1</sub> m7	d <sub>2</sub> h6	l <sub>1</sub>	l <sub>2</sub>	l <sub>3</sub>	l <sub>4</sub>	Spezifikation	Bestell-Nr.
3,00	6	62	20	14	36	M6003-0300AW	30245178
3,10	6	62	20	14	36	M6003-0310AW	30245180
3,20	6	62	20	14	36	M6003-0320AW	30245182
3,30	6	62	20	14	36	M6003-0330AW	30245184
3,40	6	62	20	14	36	M6003-0340AW	30245186
3,50	6	62	20	14	36	M6003-0350AW	30245188
3,60	6	62	20	14	36	M6003-0360AW	30245190
3,70*	6	62	20	14	36	M6003-0370AW	30245192
3,80	6	66	24	17	36	M6003-0380AW	30245194
3,90	6	66	24	17	36	M6003-0390AW	30245196
4,00	6	66	24	17	36	M6003-0400AW	30245198
4,02	6	66	24	17	36	M6003-0402AW	30356830
4,10	6	66	24	17	36	M6003-0410AW	30245200
4,20	6	66	24	17	36	M6003-0420AW	30245202
4,30	6	66	24	17	36	M6003-0430AW	30245204
4,40	6	66	24	17	36	M6003-0440AW	30245206
4,50	6	66	24	17	36	M6003-0450AW	30245208
4,60	6	66	24	17	36	M6003-0460AW	30245210
4,65*	6	66	24	17	36	M6003-0465AW	30245212
4,70	6	66	24	17	36	M6003-0470AW	30245214
4,80	6	66	28	20	36	M6003-0480AW	30245216
4,90	6	66	28	20	36	M6003-0490AW	30245218
5,00	6	66	28	20	36	M6003-0500AW	30245220
5,10	6	66	28	20	36	M6003-0510AW	30245222
5,20	6	66	28	20	36	M6003-0520AW	30245224
5,30	6	66	28	20	36	M6003-0530AW	30245226
5,40	6	66	28	20	36	M6003-0540AW	30245228
5,50	6	66	28	20	36	M6003-0550AW	30245230
5,55*	6	66	28	20	36	M6003-0555AW	30245232
5,60	6	66	28	20	36	M6003-0560AW	30245234
5,70	6	66	28	20	36	M6003-0570AW	30245236
5,80	6	66	28	20	36	M6003-0580AW	30245238
5,90	6	66	28	20	36	M6003-0590AW	30245240
6,00	6	66	28	20	36	M6003-0600AW	30245242
6,10	8	79	34	24	36	M6003-0610AW	30245244



## ECU-Drill-Steel | Vollhartmetall-Spiralbohrer M6003 (3xD), äußere Kühlmittelzufuhr

Baumaße						Schaftform HA	
d <sub>1</sub> m7	d <sub>2</sub> h6	l <sub>1</sub>	l <sub>2</sub>	l <sub>3</sub>	l <sub>4</sub>	Spezifikation	Bestell-Nr.
6,20	8	79	34	24	36	M6003-0620AW	30245246
6,30	8	79	34	24	36	M6003-0630AW	30245248
6,40	8	79	34	24	36	M6003-0640AW	30245250
6,50	8	79	34	24	36	M6003-0650AW	30245252
6,60	8	79	34	24	36	M6003-0660AW	30245254
6,70	8	79	34	24	36	M6003-0670AW	30245256
6,80	8	79	34	24	36	M6003-0680AW	30245258
6,90	8	79	34	24	36	M6003-0690AW	30245260
7,00	8	79	34	24	36	M6003-0700AW	30245262
7,10	8	79	41	29	36	M6003-0710AW	30245264
7,20	8	79	41	29	36	M6003-0720AW	30245266
7,30	8	79	41	29	36	M6003-0730AW	30245268
7,40	8	79	41	29	36	M6003-0740AW	30245270
7,50	8	79	41	29	36	M6003-0750AW	30245272
7,60	8	79	41	29	36	M6003-0760AW	30245274
7,70	8	79	41	29	36	M6003-0770AW	30245276
7,80	8	79	41	29	36	M6003-0780AW	30245278
7,90	8	79	41	29	36	M6003-0790AW	30245280
8,00	8	79	41	29	36	M6003-0800AW	30245282
8,10	10	89	47	35	40	M6003-0810AW	30245284
8,20	10	89	47	35	40	M6003-0820AW	30245286
8,30	10	89	47	35	40	M6003-0830AW	30245288
8,40	10	89	47	35	40	M6003-0840AW	30245290
8,50	10	89	47	35	40	M6003-0850AW	30245292
8,60	10	89	47	35	40	M6003-0860AW	30245294
8,70	10	89	47	35	40	M6003-0870AW	30245296
8,80	10	89	47	35	40	M6003-0880AW	30245298
8,90	10	89	47	35	40	M6003-0890AW	30245300
9,00	10	89	47	35	40	M6003-0900AW	30245302
9,10	10	89	47	35	40	M6003-0910AW	30245304
9,20	10	89	47	35	40	M6003-0920AW	30245306
9,30*	10	89	47	35	40	M6003-0930AW	30245308
9,40	10	89	47	35	40	M6003-0940AW	30245310
9,50	10	89	47	35	40	M6003-0950AW	30245312
9,60	10	89	47	35	40	M6003-0960AW	30245314
9,70	10	89	47	35	40	M6003-0970AW	30245316
9,80	10	89	47	35	40	M6003-0980AW	30245318
9,90	10	89	47	35	40	M6003-0990AW	30245320
10,00	10	89	47	35	40	M6003-1000AW	30245322
10,10	12	102	55	40	45	M6003-1010AW	30245324
10,20	12	102	55	40	45	M6003-1020AW	30245326
10,30	12	102	55	40	45	M6003-1030AW	30245328
10,40	12	102	55	40	45	M6003-1040AW	30245330
10,50	12	102	55	40	45	M6003-1050AW	30245332
10,60	12	102	55	40	45	M6003-1060AW	30245334
10,70	12	102	55	40	45	M6003-1070AW	30245336
10,80	12	102	55	40	45	M6003-1080AW	30245340
10,90	12	102	55	40	45	M6003-1090AW	30245342
11,00	12	102	55	40	45	M6003-1100AW	30245344
11,10	12	102	55	40	45	M6003-1110AW	30245346
11,20*	12	102	55	40	45	M6003-1120AW	30245348
11,30	12	102	55	40	45	M6003-1130AW	30245350
11,40	12	102	55	40	45	M6003-1140AW	30245352
11,50	12	102	55	40	45	M6003-1150AW	30245354
11,60	12	102	55	40	45	M6003-1160AW	30245356
11,70	12	102	55	40	45	M6003-1170AW	30245358
11,80	12	102	55	40	45	M6003-1180AW	30245360

Fortsetzung auf nächster Seite.

## ECU-Drill-Steel | Vollhartmetall-Spiralbohrer M6003 (3xD), äußere Kühlmittelzufuhr

Baumaße						Schaftform HA	
d <sub>1</sub> m7	d <sub>2</sub> h6	l <sub>1</sub>	l <sub>2</sub>	l <sub>3</sub>	l <sub>4</sub>	Spezifikation	Bestell-Nr.
11,90	12	102	55	40	45	M6003-1190AW	30245362
12,00	12	102	55	40	45	M6003-1200AW	30245364
12,20	14	107	60	43	45	M6003-1220AW	30455870
12,25	14	107	60	43	45	M6003-1225AW	30245366
12,50	14	107	60	43	45	M6003-1250AW	30245368
12,70	14	107	60	43	45	M6003-1270AW	30245370
12,80	14	107	60	43	45	M6003-1280AW	30245372
13,00	14	107	60	43	45	M6003-1300AW	30245376
13,30	14	107	60	43	45	M6003-1330AW	30353712
13,50	14	107	60	43	45	M6003-1350AW	30245382
13,70	14	107	60	43	45	M6003-1370AW	30245384
13,80	14	107	60	43	45	M6003-1380AW	30245386
14,00	14	107	60	43	45	M6003-1400AW	30245388
14,20	16	115	65	45	48	M6003-1420AW	30245390
14,50	16	115	65	45	48	M6003-1450AW	30245392
14,70	16	115	65	45	48	M6003-1470AW	30250941
15,00	16	115	65	45	48	M6003-1500AW	30245396
15,25	16	115	65	45	48	M6003-1525AW	30245400
15,30	16	115	65	45	48	M6003-1530AW	30245402
15,50	16	115	65	45	48	M6003-1550AW	30245404
15,80	16	115	65	45	48	M6003-1580AW	30245406
16,00	16	115	65	45	48	M6003-1600AW	30245408
16,50	18	123	73	51	48	M6003-1650AW	30245410
16,80	18	123	73	51	48	M6003-1680AW	30245412
17,00	18	123	73	51	48	M6003-1700AW	30245414
17,50	18	123	73	51	48	M6003-1750AW	30245416
17,80	18	123	73	51	48	M6003-1780AW	30245418
18,00	18	123	73	51	48	M6003-1800AW	30245420
18,50	20	131	79	55	50	M6003-1850AW	30245422
19,00	20	131	79	55	50	M6003-1900AW	30245426
19,50	20	131	79	55	50	M6003-1950AW	30245428
19,80	20	131	79	55	50	M6003-1980AW	30245430
20,00	20	131	79	55	50	M6003-2000AW	30245432

## Konfigurierbare Merkmale



**Schaftform:**  
Schaftform: HB | HE



**Spezifikation:**  
M6003-1550[Schaftform]W

**Beispiel:**  
M6003-1550EW

Schaftform HE

Maßangaben in mm.

\* Speziell zur Vorfertigung der Kernlöcher für Gewindeformer geeignet.

Schnittwertempfehlung siehe Kapitelende.

Sonderausführungen und andere Beschichtungen auf Anfrage.

# ECU-Drill-Steel

Vollhartmetall-Spiralbohrer  
M6105 (5xD), innere Kühlmittelzufuhr

**Ausführung:**  
Bohrerdurchmesser: 3,00 - 20,00 mm  
Bohrungstoleranz:  $\geq$  IT 9  
Beschichtung: Mx4  
Schneidenanzahl: 2  
Spitzenwinkel: 140°  
Spiralwinkel: 30°

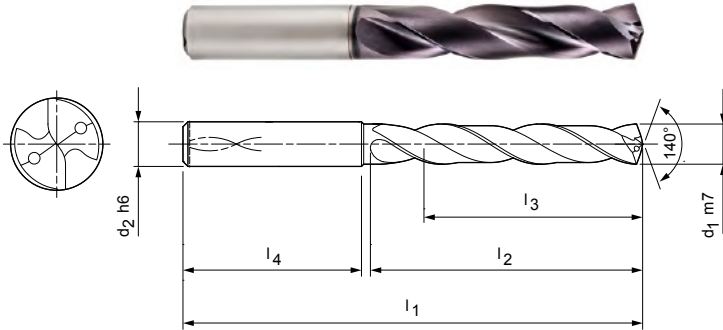

## Lagerhaltige Vorzugsbaureihe in Schaftform HA

Baumaße						Schaftform HA	
d <sub>1</sub> m7	d <sub>2</sub> h6	l <sub>1</sub>	l <sub>2</sub>	l <sub>3</sub>	l <sub>4</sub>	Spezifikation	Bestell-Nr.
3,00	6	66	28	23	36	M6105-0300AW	30245999
3,10	6	66	28	23	36	M6105-0310AW	30246001
3,20	6	66	28	23	36	M6105-0320AW	30246003
3,30	6	66	28	23	36	M6105-0330AW	30246006
3,40	6	66	28	23	36	M6105-0340AW	30246008
3,50	6	66	28	23	36	M6105-0350AW	30246010
3,60	6	66	28	23	36	M6105-0360AW	30246012
3,70*	6	66	28	23	36	M6105-0370AW	30246014
3,80	6	74	36	29	36	M6105-0380AW	30246016
3,90	6	74	36	29	36	M6105-0390AW	30246018
4,00	6	74	36	29	36	M6105-0400AW	30246020
4,10	6	74	36	29	36	M6105-0410AW	30246022
4,20	6	74	36	29	36	M6105-0420AW	30246024
4,30	6	74	36	29	36	M6105-0430AW	30246027
4,40	6	74	36	29	36	M6105-0440AW	30246029
4,50	6	74	36	29	36	M6105-0450AW	30246031
4,60	6	74	36	29	36	M6105-0460AW	30246033
4,65*	6	74	36	29	36	M6105-0465AW	30246035
4,70	6	74	36	29	36	M6105-0470AW	30246037
4,80	6	82	44	35	36	M6105-0480AW	30246039
4,90	6	82	44	35	36	M6105-0490AW	30246041
5,00	6	82	44	35	36	M6105-0500AW	30246044
5,10	6	82	44	35	36	M6105-0510AW	30246047
5,20	6	82	44	35	36	M6105-0520AW	30246049
5,30	6	82	44	35	36	M6105-0530AW	30246051
5,40	6	82	44	35	36	M6105-0540AW	30246053
5,50	6	82	44	35	36	M6105-0550AW	30246055
5,55*	6	82	44	35	36	M6105-0555AW	30246057
5,60	6	82	44	35	36	M6105-0560AW	30246059
5,70	6	82	44	35	36	M6105-0570AW	30246061
5,80	6	82	44	35	36	M6105-0580AW	30246064
5,90	6	82	44	35	36	M6105-0590AW	30246066
6,00	6	82	44	35	36	M6105-0600AW	30246068
6,10	8	91	53	43	36	M6105-0610AW	30246070
6,20	8	91	53	43	36	M6105-0620AW	30246072

## ECU-Drill-Steel | Vollhartmetall-Spiralbohrer M6105 (5xD), innere Kühlmittelzufuhr

Baumaße						Schaftform HA	
d <sub>1</sub> m7	d <sub>2</sub> h6	l <sub>1</sub>	l <sub>2</sub>	l <sub>3</sub>	l <sub>4</sub>	Spezifikation	Bestell-Nr.
6,30	8	91	53	43	36	M6105-0630AW	30246074
6,40	8	91	53	43	36	M6105-0640AW	30246076
6,50	8	91	53	43	36	M6105-0650AW	30246078
6,60	8	91	53	43	36	M6105-0660AW	30246080
6,70	8	91	53	43	36	M6105-0670AW	30246082
6,80	8	91	53	43	36	M6105-0680AW	30246084
6,90	8	91	53	43	36	M6105-0690AW	30246086
7,00	8	91	53	43	36	M6105-0700AW	30246088
7,10	8	91	53	43	36	M6105-0710AW	30246090
7,20	8	91	53	43	36	M6105-0720AW	30246092
7,30	8	91	53	43	36	M6105-0730AW	30246094
7,40	8	91	53	43	36	M6105-0740AW	30246096
7,45*	8	91	53	43	36	M6105-0745AW	30246098
7,50	8	91	53	43	36	M6105-0750AW	30246099
7,60	8	91	53	43	36	M6105-0760AW	30246101
7,70	8	91	53	43	36	M6105-0770AW	30246103
7,80	8	91	53	43	36	M6105-0780AW	30246105
7,90	8	91	53	43	36	M6105-0790AW	30246107
8,00	8	91	53	43	36	M6105-0800AW	30246109
8,10	10	103	61	49	40	M6105-0810AW	30246111
8,20	10	103	61	49	40	M6105-0820AW	30246113
8,30	10	103	61	49	40	M6105-0830AW	30246115
8,40	10	103	61	49	40	M6105-0840AW	30246117
8,50	10	103	61	49	40	M6105-0850AW	30246119
8,60	10	103	61	49	40	M6105-0860AW	30246121
8,70	10	103	61	49	40	M6105-0870AW	30246123
8,80	10	103	61	49	40	M6105-0880AW	30246125
8,90	10	103	61	49	40	M6105-0890AW	30246127
9,00	10	103	61	49	40	M6105-0900AW	30246129
9,10	10	103	61	49	40	M6105-0910AW	30246131
9,20	10	103	61	49	40	M6105-0920AW	30246133
9,30*	10	103	61	49	40	M6105-0930AW	30246135
9,35	10	103	61	49	40	M6105-0935AW	30246137
9,40	10	103	61	49	40	M6105-0940AW	30246138
9,50	10	103	61	49	40	M6105-0950AW	30246140
9,60	10	103	61	49	40	M6105-0960AW	30246142
9,70	10	103	61	49	40	M6105-0970AW	30246144
9,80	10	103	61	49	40	M6105-0980AW	30246146
9,90	10	103	61	49	40	M6105-0990AW	30246148
10,00	10	103	61	49	40	M6105-1000AW	30246150
10,10	12	118	71	56	45	M6105-1010AW	30246152
10,20	12	118	71	56	45	M6105-1020AW	30246154
10,30	12	118	71	56	45	M6105-1030AW	30246156
10,40	12	118	71	56	45	M6105-1040AW	30246158
10,50	12	118	71	56	45	M6105-1050AW	30246160
10,60	12	118	71	56	45	M6105-1060AW	30246163
10,70	12	118	71	56	45	M6105-1070AW	30246165
10,80	12	118	71	56	45	M6105-1080AW	30246169
10,90	12	118	71	56	45	M6105-1090AW	30246171
11,00	12	118	71	56	45	M6105-1100AW	30246173
11,10	12	118	71	56	45	M6105-1110AW	30246175
11,20*	12	118	71	56	45	M6105-1120AW	30246177
11,25	12	118	71	56	45	M6105-1125AW	30353723
11,30	12	118	71	56	45	M6105-1130AW	30246179
11,40	12	118	71	56	45	M6105-1140AW	30246181
11,50	12	118	71	56	45	M6105-1150AW	30246183
11,60	12	118	71	56	45	M6105-1160AW	30246185

## ECU-Drill-Steel | Vollhartmetall-Spiralbohrer M6105 (5xD), innere Kühlmittelzufuhr

Baumaße						Schaftform HA	
d <sub>1</sub> m7	d <sub>2</sub> h6	l <sub>1</sub>	l <sub>2</sub>	l <sub>3</sub>	l <sub>4</sub>	Spezifikation	Bestell-Nr.
11,70	12	118	71	56	45	M6105-1170AW	30246187
11,80	12	118	71	56	45	M6105-1180AW	30246189
11,90	12	118	71	56	45	M6105-1190AW	30246191
12,00	12	118	71	56	45	M6105-1200AW	30246193
12,20	14	124	77	60	45	M6105-1220AW	30530756
12,25	14	124	77	60	45	M6105-1225AW	30246195
12,50	14	124	77	60	45	M6105-1250AW	30246197
12,70	14	124	77	60	45	M6105-1270AW	30246199
12,80	14	124	77	60	45	M6105-1280AW	30246201
12,90	14	124	77	60	45	M6105-1290AW	30246203
13,00	14	124	77	60	45	M6105-1300AW	30246205
13,10	14	124	77	60	45	M6105-1310AW	30246207
13,20	14	124	77	60	45	M6105-1320AW	30246209
13,50	14	124	77	60	45	M6105-1350AW	30246211
13,70	14	124	77	60	45	M6105-1370AW	30246213
13,80	14	124	77	60	45	M6105-1380AW	30246215
14,00	14	124	77	60	45	M6105-1400AW	30246217
14,20	16	133	83	63	48	M6105-1420AW	30246219
14,50	16	133	83	63	48	M6105-1450AW	30246221
14,70	16	133	83	63	48	M6105-1470AW	30250906
14,80	16	133	83	63	48	M6105-1480AW	30246223
15,00	16	133	83	63	48	M6105-1500AW	30246225
15,10	16	133	83	63	48	M6105-1510AW	30246227
15,25	16	133	83	63	48	M6105-1525AW	30246229
15,30	16	133	83	63	48	M6105-1530AW	30246231
15,50	16	133	83	63	48	M6105-1550AW	30246233
15,70	16	133	83	63	48	M6105-1570AW	30250907
15,80	16	133	83	63	48	M6105-1580AW	30246236
16,00	16	133	83	63	48	M6105-1600AW	30246238
16,50	18	143	93	71	48	M6105-1650AW	30246240
16,80	18	143	93	71	48	M6105-1680AW	30246242
17,00	18	143	93	71	48	M6105-1700AW	30246245
17,50	18	143	93	71	48	M6105-1750AW	30246247
17,80	18	143	93	71	48	M6105-1780AW	30246250
18,00	18	143	93	71	48	M6105-1800AW	30246252
18,50	20	153	101	77	50	M6105-1850AW	30246254
18,80	20	153	101	77	50	M6105-1880AW	30246256
19,00	20	153	101	77	50	M6105-1900AW	30246259
19,50	20	153	101	77	50	M6105-1950AW	30246261
19,80	20	153	101	77	50	M6105-1980AW	30246264
20,00	20	153	101	77	50	M6105-2000AW	30246266

Fortsetzung auf nächster Seite.

**ECU-Drill-Steel | Vollhartmetall-Spiralbohrer M6105 (5xD), innere Kühlmittelzufuhr****Konfigurierbare Merkmale**

**Schaftform:**  
Schaftform: HB | HE

**Spezifikation:**

M6105-1550[Schaftform]W

**Beispiel:**  
M6105-1550EW

Schaftform HE

Maßangaben in mm.

\* Speziell zur Vorfertigung der Kernlöcher für Gewindeformer geeignet.

Schnittwertempfehlung siehe Kapitelende.

Sonderausführungen und andere Beschichtungen auf Anfrage.

# ECU-Drill-Steel

Vollhartmetall-Spiralbohrer  
M6005 (5xD), äußere Kühlmittelzufuhr

**Ausführung:**  
Bohrerdurchmesser: 3,00 - 20,00 mm  
Bohrungstoleranz:  $\geq$  IT 9  
Beschichtung: Mx4  
Schneidenanzahl: 2  
Spitzenwinkel: 140°  
Spiralwinkel: 30°

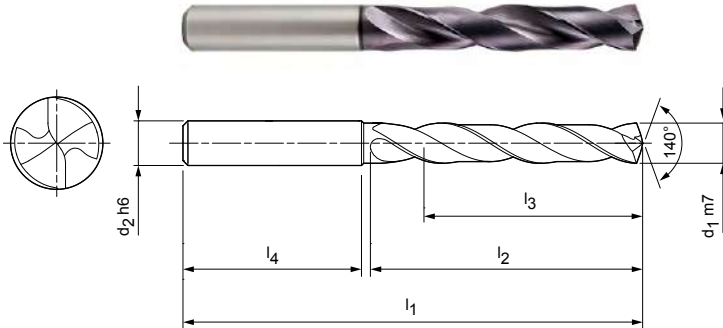

## Lagerhaltige Vorzugsbaureihe in Schaftform HA

Baumaße						Schaftform HA	
d <sub>1</sub> m7	d <sub>2</sub> h6	l <sub>1</sub>	l <sub>2</sub>	l <sub>3</sub>	l <sub>4</sub>	Spezifikation	Bestell-Nr.
3,00	6	66	28	23	36	M6005-0300AW	30245454
3,10	6	66	28	23	36	M6005-0310AW	30245456
3,20	6	66	28	23	36	M6005-0320AW	30245458
3,30	6	66	28	23	36	M6005-0330AW	30245460
3,40	6	66	28	23	36	M6005-0340AW	30245462
3,50	6	66	28	23	36	M6005-0350AW	30245464
3,60	6	66	28	23	36	M6005-0360AW	30245466
3,70*	6	66	28	23	36	M6005-0370AW	30245468
3,80	6	74	36	29	36	M6005-0380AW	30245470
3,90	6	74	36	29	36	M6005-0390AW	30245472
4,00	6	74	36	29	36	M6005-0400AW	30245474
4,10	6	74	36	29	36	M6005-0410AW	30245476
4,20	6	74	36	29	36	M6005-0420AW	30245478
4,30	6	74	36	29	36	M6005-0430AW	30245480
4,40	6	74	36	29	36	M6005-0440AW	30245482
4,50	6	74	36	29	36	M6005-0450AW	30245484
4,60	6	74	36	29	36	M6005-0460AW	30245486
4,65*	6	74	36	29	36	M6005-0465AW	30245488
4,70	6	74	36	29	36	M6005-0470AW	30245490
4,80	6	82	44	35	36	M6005-0480AW	30245492
4,90	6	82	44	35	36	M6005-0490AW	30245494
5,00	6	82	44	35	36	M6005-0500AW	30245496
5,10	6	82	44	35	36	M6005-0510AW	30245498
5,20	6	82	44	35	36	M6005-0520AW	30245500
5,30	6	82	44	35	36	M6005-0530AW	30245502
5,40	6	82	44	35	36	M6005-0540AW	30245504
5,50	6	82	44	35	36	M6005-0550AW	30245506
5,55*	6	82	44	35	36	M6005-0555AW	30245508
5,60	6	82	44	35	36	M6005-0560AW	30245510
5,70	6	82	44	35	36	M6005-0570AW	30245512
5,80	6	82	44	35	36	M6005-0580AW	30245514
5,90	6	82	44	35	36	M6005-0590AW	30245516
6,00	6	82	44	35	36	M6005-0600AW	30245518
6,10	8	91	53	43	36	M6005-0610AW	30245520
6,20	8	91	53	43	36	M6005-0620AW	30245522

## ECU-Drill-Steel | Vollhartmetall-Spiralbohrer M6005 (5xD), äußere Kühlmittelzufuhr

Baumaße						Schaftform HA	
d <sub>1</sub> m7	d <sub>2</sub> h6	l <sub>1</sub>	l <sub>2</sub>	l <sub>3</sub>	l <sub>4</sub>	Spezifikation	Bestell-Nr.
6,30	8	91	53	43	36	M6005-0630AW	30245524
6,40	8	91	53	43	36	M6005-0640AW	30245526
6,50	8	91	53	43	36	M6005-0650AW	30245528
6,60	8	91	53	43	36	M6005-0660AW	30245530
6,70	8	91	53	43	36	M6005-0670AW	30245532
6,80	8	91	53	43	36	M6005-0680AW	30245534
6,90	8	91	53	43	36	M6005-0690AW	30245536
7,00	8	91	53	43	36	M6005-0700AW	30245538
7,10	8	91	53	43	36	M6005-0710AW	30245540
7,20	8	91	53	43	36	M6005-0720AW	30245542
7,30	8	91	53	43	36	M6005-0730AW	30245544
7,40	8	91	53	43	36	M6005-0740AW	30245546
7,50	8	91	53	43	36	M6005-0750AW	30245548
7,60	8	91	53	43	36	M6005-0760AW	30245550
7,70	8	91	53	43	36	M6005-0770AW	30245552
7,80	8	91	53	43	36	M6005-0780AW	30245554
7,90	8	91	53	43	36	M6005-0790AW	30245556
8,00	8	91	53	43	36	M6005-0800AW	30245558
8,10	10	103	61	49	40	M6005-0810AW	30245560
8,20	10	103	61	49	40	M6005-0820AW	30245562
8,30	10	103	61	49	40	M6005-0830AW	30245564
8,40	10	103	61	49	40	M6005-0840AW	30245566
8,50	10	103	61	49	40	M6005-0850AW	30245568
8,60	10	103	61	49	40	M6005-0860AW	30245570
8,70	10	103	61	49	40	M6005-0870AW	30245572
8,80	10	103	61	49	40	M6005-0880AW	30245574
8,90	10	103	61	49	40	M6005-0890AW	30245576
9,00	10	103	61	49	40	M6005-0900AW	30245578
9,10	10	103	61	49	40	M6005-0910AW	30245580
9,20	10	103	61	49	40	M6005-0920AW	30245582
9,30*	10	103	61	49	40	M6005-0930AW	30245584
9,40	10	103	61	49	40	M6005-0940AW	30245586
9,50	10	103	61	49	40	M6005-0950AW	30245588
9,60	10	103	61	49	40	M6005-0960AW	30245590
9,70	10	103	61	49	40	M6005-0970AW	30245592
9,80	10	103	61	49	40	M6005-0980AW	30245594
9,90	10	103	61	49	40	M6005-0990AW	30245596
10,00	10	103	61	49	40	M6005-1000AW	30245598
10,10	12	118	71	56	45	M6005-1010AW	30245600
10,20	12	118	71	56	45	M6005-1020AW	30245602
10,30	12	118	71	56	45	M6005-1030AW	30245604
10,40	12	118	71	56	45	M6005-1040AW	30245606
10,50	12	118	71	56	45	M6005-1050AW	30245608
10,60	12	118	71	56	45	M6005-1060AW	30245610
10,80	12	118	71	56	45	M6005-1080AW	30245616
11,00	12	118	71	56	45	M6005-1100AW	30245620
11,10	12	118	71	56	45	M6005-1110AW	30245622
11,20*	12	118	71	56	45	M6005-1120AW	30245624
11,30	12	118	71	56	45	M6005-1130AW	30245626
11,40	12	118	71	56	45	M6005-1140AW	30245628
11,50	12	118	71	56	45	M6005-1150AW	30245630
11,60	12	118	71	56	45	M6005-1160AW	30245632
11,70	12	118	71	56	45	M6005-1170AW	30245634
11,80	12	118	71	56	45	M6005-1180AW	30245636
11,90	12	118	71	56	45	M6005-1190AW	30245638
12,00	12	118	71	56	45	M6005-1200AW	30245640
12,20	14	124	77	60	45	M6005-1220AW	30530754



## ECU-Drill-Steel | Vollhartmetall-Spiralbohrer M6005 (5xD), äußere Kühlmittelzufuhr

Baumaße						Schaftform HA	
d <sub>1</sub> m7	d <sub>2</sub> h6	l <sub>1</sub>	l <sub>2</sub>	l <sub>3</sub>	l <sub>4</sub>	Spezifikation	Bestell-Nr.
12,50	14	124	77	60	45	M6005-1250AW	30245644
12,70	14	124	77	60	45	M6005-1270AW	30245646
12,80	14	124	77	60	45	M6005-1280AW	30245648
13,00	14	124	77	60	45	M6005-1300AW	30245652
13,10	14	124	77	60	45	M6005-1310AW	30245654
13,50	14	124	77	60	45	M6005-1350AW	30245658
13,70	14	124	77	60	45	M6005-1370AW	30245660
13,80	14	124	77	60	45	M6005-1380AW	30245662
14,00	14	124	77	60	45	M6005-1400AW	30245664
14,20	16	133	83	63	48	M6005-1420AW	30245666
14,50	16	133	83	63	48	M6005-1450AW	30245668
14,70	16	133	83	63	48	M6005-1470AW	30250932
14,80	16	133	83	63	48	M6005-1480AW	30245670
15,00	16	133	83	63	48	M6005-1500AW	30245672
15,50	16	133	83	63	48	M6005-1550AW	30245680
15,70	16	133	83	63	48	M6005-1570AW	30250933
15,80	16	133	83	63	48	M6005-1580AW	30245682
16,00	16	133	83	63	48	M6005-1600AW	30245684
16,50	18	143	93	71	48	M6005-1650AW	30245686
17,00	18	143	93	71	48	M6005-1700AW	30245690
17,50	18	143	93	71	48	M6005-1750AW	30245692
18,00	18	143	93	71	48	M6005-1800AW	30245696
18,50	20	153	101	77	50	M6005-1850AW	30245698
18,80	20	153	101	77	50	M6005-1880AW	30245700
19,00	20	153	101	77	50	M6005-1900AW	30245702
19,80	20	153	101	77	50	M6005-1980AW	30245706
20,00	20	153	101	77	50	M6005-2000AW	30245708

## Konfigurierbare Merkmale



**Schaftform:**  
Schaftform: HB | HE



**Spezifikation:**  
M6005-1550[Schaftform]W

Beispiel:  
M6005-1550EW

Schaftform HE

Maßangaben in mm.

\* Speziell zur Vorfertigung der Kernlöcher für Gewindeformer geeignet.  
Schnittwertempfehlung siehe Kapitelende.

Sonderausführungen und andere Beschichtungen auf Anfrage.

# ECU-Drill-Steel

Vollhartmetall-Spiralbohrer  
M6108 (8xD), innere Kühlmittelzufuhr

**Ausführung:**

Bohrerdurchmesser: 3,00 - 20,00 mm  
Bohrungstoleranz:  $\geq$  IT 9  
Beschichtung: MxF  
Schneidenanzahl: 2  
Spitzenwinkel: 135°  
Spiralwinkel: 30°

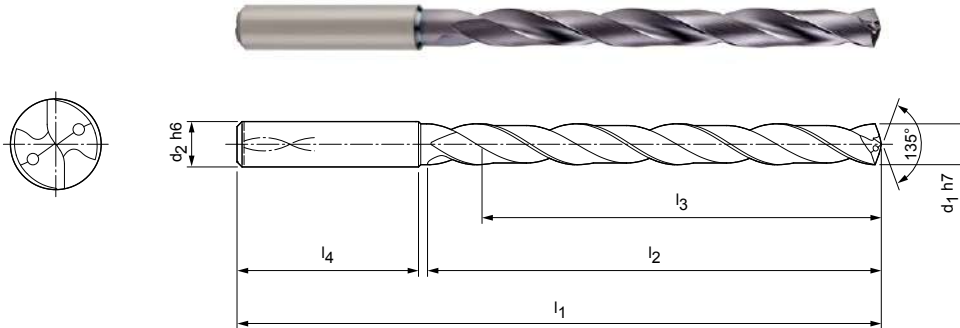

**Lagerhaltige Vorzugsbaureihe in Schaftform HA**

Baumaße						Schaftform HA	
d <sub>1</sub> h7	d <sub>2</sub> h6	l <sub>1</sub>	l <sub>2</sub>	l <sub>3</sub>	l <sub>4</sub>	Spezifikation	Bestell-Nr.
3,00	6	72	34	29	36	M6108-0300AE	30440502
3,10	6	72	34	29	36	M6108-0310AE	30440503
3,20	6	72	34	29	36	M6108-0320AE	30440504
3,30	6	72	34	29	36	M6108-0330AE	30440505
3,40	6	72	34	29	36	M6108-0340AE	30440507
3,50	6	72	34	29	36	M6108-0350AE	30440508
3,60	6	72	34	29	36	M6108-0360AE	30440509
3,70	6	72	34	29	36	M6108-0370AE	30440510
3,80	6	81	43	36	36	M6108-0380AE	30440511
3,90	6	81	43	36	36	M6108-0390AE	30440512
4,00	6	81	43	36	36	M6108-0400AE	30440513
4,10	6	81	43	36	36	M6108-0410AE	30440514
4,20	6	81	43	36	36	M6108-0420AE	30440516
4,30	6	81	43	36	36	M6108-0430AE	30440517
4,40	6	81	43	36	36	M6108-0440AE	30440518
4,50	6	81	43	36	36	M6108-0450AE	30440520
4,60	6	81	43	36	36	M6108-0460AE	30440521
4,70	6	81	43	36	36	M6108-0470AE	30440522
4,80	6	95	57	48	36	M6108-0480AE	30440523
4,90	6	95	57	48	36	M6108-0490AE	30440526
5,00	6	95	57	48	36	M6108-0500AE	30440527
5,10	6	95	57	48	36	M6108-0510AE	30440528
5,20	6	95	57	48	36	M6108-0520AE	30440529
5,30	6	95	57	48	36	M6108-0530AE	30440534
5,50	6	95	57	48	36	M6108-0550AE	30440536
5,70	6	95	57	48	36	M6108-0570AE	30531658
5,80	6	95	57	48	36	M6108-0580AE	30440537
5,90	6	95	57	48	36	M6108-0590AE	30440538
6,00	6	95	57	48	36	M6108-0600AE	30440540
6,10	8	114	76	64	36	M6108-0610AE	30440560
6,20	8	114	76	64	36	M6108-0620AE	30440561
6,30	8	114	76	64	36	M6108-0630AE	30440563
6,50	8	114	76	64	36	M6108-0650AE	30440564
6,60	8	114	76	64	36	M6108-0660AE	30440565
6,70	8	114	76	64	36	M6108-0670AE	30531661

## ECU-Drill-Steel | Vollhartmetall-Spiralbohrer M6108 (8xD), innere Kühlmittelzufuhr

Baumaße						Schaftform HA	
d <sub>1</sub> h7	d <sub>2</sub> h6	l <sub>1</sub>	l <sub>2</sub>	l <sub>3</sub>	l <sub>4</sub>	Spezifikation	Bestell-Nr.
6,80	8	114	76	64	36	M6108-0680AE	30440567
6,90	8	114	76	64	36	M6108-0690AE	30531663
7,00	8	114	76	64	36	M6108-0700AE	30440570
7,10	8	114	76	64	36	M6108-0710AE	30531664
7,40	8	114	76	64	36	M6108-0740AE	30440571
7,50	8	114	76	64	36	M6108-0750AE	30440573
7,70	8	114	76	64	36	M6108-0770AE	30440574
7,80	8	114	76	64	36	M6108-0780AE	30440577
7,90	8	114	76	64	36	M6108-0790AE	30440580
8,00	8	114	76	64	36	M6108-0800AE	30440583
8,10	10	142	95	80	40	M6108-0810AE	30440585
8,20	10	142	95	80	40	M6108-0820AE	30440587
8,30	10	142	95	80	40	M6108-0830AE	30440589
8,50	10	142	95	80	40	M6108-0850AE	30440590
8,60	10	142	95	80	40	M6108-0860AE	30440591
8,70	10	142	95	80	40	M6108-0870AE	30440593
8,80	10	142	95	80	40	M6108-0880AE	30440601
9,00	10	142	95	80	40	M6108-0900AE	30440604
9,10	10	142	95	80	40	M6108-0910AE	30440606
9,20	10	142	95	80	40	M6108-0920AE	30440608
9,30	10	142	95	80	40	M6108-0930AE	30440611
9,40	10	142	95	80	40	M6108-0940AE	30440612
9,50	10	142	95	80	40	M6108-0950AE	30440613
9,70	10	142	95	80	40	M6108-0970AE	30440614
9,80	10	142	95	80	40	M6108-0980AE	30440615
9,90	10	142	95	80	40	M6108-0990AE	30440618
10,00	10	142	95	80	40	M6108-1000AE	30440620
10,20	12	162	114	96	45	M6108-1020AE	30440624
10,30	12	162	114	96	45	M6108-1030AE	30531672
10,50	12	162	114	96	45	M6108-1050AE	30440625
10,80	12	162	114	96	45	M6108-1080AE	30440626
11,00	12	162	114	96	45	M6108-1100AE	30440628
11,20	12	162	114	96	45	M6108-1120AE	30440630
11,50	12	162	114	96	45	M6108-1150AE	30440631
11,70	12	162	114	96	45	M6108-1170AE	30531683
11,80	12	162	114	96	45	M6108-1180AE	30440632
12,00	12	162	114	96	45	M6108-1200AE	30440634
12,20	14	178	133	112	45	M6108-1220AE	30520277
12,50	14	178	133	112	45	M6108-1250AE	30440635
12,80	14	178	133	112	45	M6108-1280AE	30507087
13,00	14	178	133	112	45	M6108-1300AE	30440636
13,50	14	178	133	112	45	M6108-1350AE	30440637
13,80	14	178	133	112	45	M6108-1380AE	30531685
14,00	14	178	133	112	45	M6108-1400AE	30440638
14,50	16	203	152	128	48	M6108-1450AE	30440640
15,00	16	203	152	128	48	M6108-1500AE	30440642
15,50	16	203	152	128	48	M6108-1550AE	30440643
15,80	16	203	152	128	48	M6108-1580AE	30508538
16,00	16	203	152	128	48	M6108-1600AE	30440644
16,50	18	222	171	144	48	M6108-1650AE	30440645
17,00	18	222	171	144	48	M6108-1700AE	30440647
17,50	18	222	171	144	48	M6108-1750AE	30440648
18,00	18	222	171	144	48	M6108-1800AE	30440649
18,50	20	243	190	160	50	M6108-1850AE	30440650
19,00	20	243	190	160	50	M6108-1900AE	30440651
20,00	20	243	190	160	50	M6108-2000AE	30440652

Fortsetzung auf nächster Seite.

**ECU-Drill-Steel | Vollhartmetall-Spiralbohrer M6108 (8xD), innere Kühlmittelzufuhr****Konfigurierbare Merkmale**

**Schaftform:**  
Schaftform: HB | HE

**Spezifikation:**

M6108-1550[Schaftform]E

**Beispiel:**  
M6108-1550EE

Schaftform HE

# ECU-Drill-Steel

Vollhartmetall-Spiralbohrer  
M6112 (12xD), innere Kühlmittelzufuhr

**Ausführung:**  
Bohrerdurchmesser: 3,00 - 18,00 mm  
Bohrungstoleranz: ≥ IT 9  
Beschichtung: MxF  
Schneidenanzahl: 2  
Spitzenwinkel: 135°  
Spiralwinkel: 30°

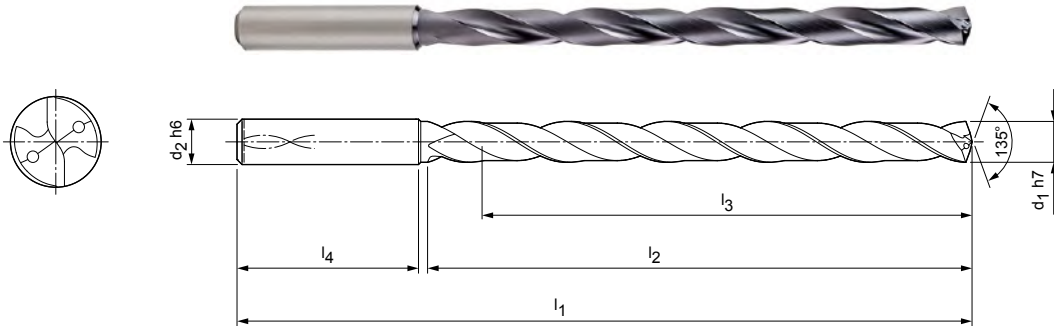

## Lagerhaltige Vorzugsbaureihe in Schaftform HA

Baumaße						Schaftform HA	
d <sub>1</sub> h7	d <sub>2</sub> h6	l <sub>1</sub>	l <sub>2</sub>	l <sub>3</sub>	l <sub>4</sub>	Spezifikation	Bestell-Nr.
3,00	6	92	54	48	36	M6112-0300AE	30440772
3,10	6	92	54	48	36	M6112-0310AE	30440774
3,20	6	92	54	48	36	M6112-0320AE	30440775
3,30	6	92	54	48	36	M6112-0330AE	30440776
3,40	6	92	54	48	36	M6112-0340AE	30440777
3,50	6	92	54	48	36	M6112-0350AE	30440781
3,60	6	92	54	48	36	M6112-0360AE	30440783
3,70	6	92	54	48	36	M6112-0370AE	30440786
3,80	6	102	64	58	36	M6112-0380AE	30440790
3,90	6	102	64	58	36	M6112-0390AE	30440791
4,00	6	102	64	58	36	M6112-0400AE	30440792
4,10	6	102	64	58	36	M6112-0410AE	30440794
4,20	6	102	64	58	36	M6112-0420AE	30440795
4,30	6	102	64	58	36	M6112-0430AE	30440796
4,40	6	102	64	58	36	M6112-0440AE	30440797
4,50	6	102	64	58	36	M6112-0450AE	30440798
4,60	6	102	64	58	36	M6112-0460AE	30440799
4,70	6	102	64	58	36	M6112-0470AE	30440800
4,80	6	116	78	70	36	M6112-0480AE	30440801
4,90	6	116	78	70	36	M6112-0490AE	30440802
5,00	6	116	78	70	36	M6112-0500AE	30440803
5,10	6	116	78	70	36	M6112-0510AE	30564194
5,20	6	116	78	70	36	M6112-0520AE	30533817
5,50	6	116	78	70	36	M6112-0550AE	30440804
5,80	6	116	78	70	36	M6112-0580AE	30440806
6,00	6	116	78	70	36	M6112-0600AE	30440807
6,30	8	146	108	94	36	M6112-0630AE	30440808
6,50	8	146	108	94	36	M6112-0650AE	30440829
6,60	8	146	108	94	36	M6112-0660AE	30440830
6,80	8	146	108	94	36	M6112-0680AE	30440831
7,00	8	146	108	94	36	M6112-0700AE	30440832
7,40	8	146	108	94	36	M6112-0740AE	30564376
7,50	8	146	108	94	36	M6112-0750AE	30440833
7,80	8	146	108	94	36	M6112-0780AE	30440834
8,00	8	146	108	94	36	M6112-0800AE	30440835

## ECU-Drill-Steel | Vollhartmetall-Spiralbohrer M6112 (12xD), innere Kühlmittelzufuhr

Baumaße						Schaftform HA	
d <sub>1</sub> h7	d <sub>2</sub> h6	l <sub>1</sub>	l <sub>2</sub>	l <sub>3</sub>	l <sub>4</sub>	Spezifikation	Bestell-Nr.
8,10	10	162	120	110	40	M6112-0810AE	30564389
8,20	10	162	120	110	40	M6112-0820AE	30440837
8,50	10	162	120	110	40	M6112-0850AE	30440838
9,00	10	162	120	110	40	M6112-0900AE	30440839
9,30	10	162	120	110	40	M6112-0930AE	30564454
9,50	10	162	120	110	40	M6112-0950AE	30440840
9,80	10	162	120	110	40	M6112-0980AE	30440841
10,00	10	162	120	110	40	M6112-1000AE	30440842
10,20	12	204	156	142	45	M6112-1020AE	30564466
10,50	12	204	156	142	45	M6112-1050AE	30440843
11,00	12	204	156	142	45	M6112-1100AE	30440844
11,50	12	204	156	142	45	M6112-1150AE	30440845
11,80	12	204	156	142	45	M6112-1180AE	30538636
12,00	12	204	156	142	45	M6112-1200AE	30440846
12,50	14	230	182	166	45	M6112-1250AE	30564480
13,00	14	230	182	166	45	M6112-1300AE	30440847
13,50	14	230	182	166	45	M6112-1350AE	30538637
14,00	14	230	182	166	45	M6112-1400AE	30440848
15,00	16	260	208	192	48	M6112-1500AE	30440850
16,00	16	260	208	192	48	M6112-1600AE	30440851
17,00	18	285	234	216	48	M6112-1700AE	30564491
17,50	18	285	234	216	48	M6112-1750AE	30505010
18,00	18	285	234	216	48	M6112-1800AE	30440852

## Konfigurierbare Merkmale



**Schaftform:**  
Schaftform: HB | HE



**Spezifikation:**  
M6112-1550[Schaftform]E

Beispiel:  
M6112-1550EE

Schaftform HE

Maßangaben in mm.

Schnittwertempfehlung siehe Kapitelende.

Sonderausführungen und andere Beschichtungen auf Anfrage.

# MEGA-Drill-Inox

Vollhartmetall-Spiralbohrer  
M1703 (3xD), äußere Kühlmittelzufuhr

**Ausführung:**

Bohrerdurchmesser: 2,00 - 20,00 mm  
Bohrungstoleranz: ≥ IT 9  
Beschichtung: MxF  
Schneidenanzahl: 2  
Anzahl Führungsfasen: 2  
Spitzenwinkel: 140°  
Spiralwinkel: 30°

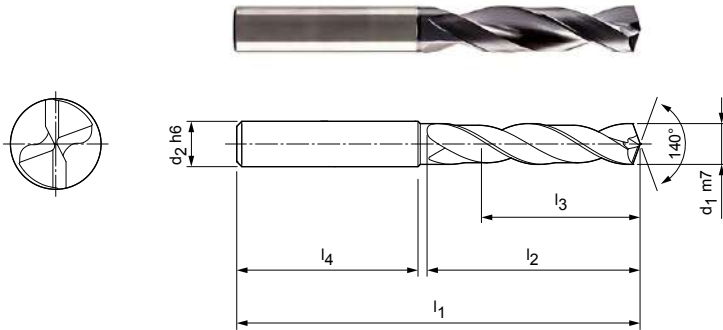

**Lagerhaltige Vorzugsbaureihe in Schaftform HA**

Baumaße						Schaftform HA	
d <sub>1</sub> m7	d <sub>2</sub> h6	l <sub>1</sub>	l <sub>2</sub>	l <sub>3</sub>	l <sub>4</sub>	Spezifikation	Bestell-Nr.
2,00	6	58	16	11	36	M1703-0200AE	30075115
2,10	6	58	16	11	36	M1703-0210AE	30320548
2,20	6	58	16	11	36	M1703-0220AE	30356480
2,30	6	58	16	11	36	M1703-0230AE	30303291
2,33	6	58	16	11	36	M1703-0233AE	30322760
2,40	6	58	16	11	36	M1703-0240AE	30075994
2,43	6	58	16	11	36	M1703-0243AE	30322761
2,50	6	58	16	11	36	M1703-0250AE	30187053
2,55	6	62	22	14	36	M1703-0255AE	30322762
2,60	6	58	16	11	36	M1703-0260AE	30308483
2,62	6	58	16	11	36	M1703-0262AE	30322764
2,70	6	58	16	11	36	M1703-0270AE	30304889
2,80	6	58	16	11	36	M1703-0280AE	30300613
2,90	6	58	16	11	36	M1703-0290AE	30309009
3,00	6	62	22	14	36	M1703-0300AE	30058987
3,10	6	62	22	14	36	M1703-0310AE	30058988
3,15	6	62	22	14	36	M1703-0315AE	30322765
3,20	6	62	22	14	36	M1703-0320AE	30141143
3,22	6	62	22	14	36	M1703-0322AE	30322766
3,25	6	62	22	14	36	M1703-0325AE	30322767
3,30	6	62	22	14	36	M1703-0330AE	30058989
3,40	6	62	22	14	36	M1703-0340AE	30058990
3,50	6	62	22	14	36	M1703-0350AE	30075976
3,60	6	62	22	14	36	M1703-0360AE	30141144
3,70	6	62	22	14	36	M1703-0370AE	30058993
3,80	6	66	26	17	36	M1703-0380AE	30140639
3,90	6	66	26	17	36	M1703-0390AE	30115800
4,00	6	66	26	17	36	M1703-0400AE	30073043
4,05	6	66	26	17	36	M1703-0405AE	30086080
4,10	6	66	26	17	36	M1703-0410AE	30080711
4,20	6	66	26	17	36	M1703-0420AE	30078111
4,30	6	66	26	17	36	M1703-0430AE	30080214
4,35	6	66	26	17	36	M1703-0435AE	30322770
4,40	6	66	26	17	36	M1703-0440AE	30058997
4,50	6	66	26	17	36	M1703-0450AE	30058999

## MEGA-Drill-Inox | Vollhartmetall-Spiralbohrer M1703 (3xD), äußere Kühlmittelzufuhr

Baumaße						Schaftform HA	
d <sub>1</sub> m7	d <sub>2</sub> h6	l <sub>1</sub>	l <sub>2</sub>	l <sub>3</sub>	l <sub>4</sub>	Spezifikation	Bestell-Nr.
4,60	6	66	26	17	36	M1703-0460AE	30075972
4,65	6	66	26	17	36	M1703-0465AE	30247452
4,70	6	66	26	17	36	M1703-0470AE	30059001
4,80	6	66	30	20	36	M1703-0480AE	30072812
4,90	6	66	30	20	36	M1703-0490AE	30059003
5,00	6	66	30	20	36	M1703-0500AE	30059004
5,03	6	66	30	20	36	M1703-0503AE	30379080
5,10	6	66	30	20	36	M1703-0510AE	30059006
5,20	6	66	30	20	36	M1703-0520AE	30073045
5,30	6	66	30	20	36	M1703-0530AE	30059007
5,40	6	66	30	20	36	M1703-0540AE	30073326
5,50	6	66	30	20	36	M1703-0550AE	30062335
5,55	6	66	30	20	36	M1703-0555AE	30247453
5,60	6	66	30	20	36	M1703-0560AE	30059008
5,70	6	66	30	20	36	M1703-0570AE	30141145
5,80	6	66	30	20	36	M1703-0580AE	30075979
5,90	6	66	30	20	36	M1703-0590AE	30141146
6,00	6	66	30	20	36	M1703-0600AE	30086931
6,10	8	79	38	24	36	M1703-0610AE	30073046
6,20	8	79	38	24	36	M1703-0620AE	30141147
6,30	8	79	38	24	36	M1703-0630AE	30059012
6,40	8	79	38	24	36	M1703-0640AE	30141148
6,50	8	79	38	24	36	M1703-0650AE	30098246
6,60	8	79	38	24	36	M1703-0660AE	30101378
6,70	8	79	38	24	36	M1703-0670AE	30141149
6,80	8	79	38	24	36	M1703-0680AE	30059016
6,90	8	79	38	24	36	M1703-0690AE	30059017
7,00	8	79	38	24	36	M1703-0700AE	30098248
7,20	8	79	42	29	36	M1703-0720AE	30141170
7,40	8	79	42	29	36	M1703-0740AE	30059022
7,45	8	79	42	29	36	M1703-0745AE	30322776
7,50	8	79	42	29	36	M1703-0750AE	30089773
7,70	8	79	42	29	36	M1703-0770AE	30059025
7,80	8	79	42	29	36	M1703-0780AE	30059026
7,90	8	79	42	29	36	M1703-0790AE	30059027
8,00	8	79	42	29	36	M1703-0800AE	30078738
8,10	10	89	49	35	40	M1703-0810AE	30141173
8,20	10	89	49	35	40	M1703-0820AE	30136765
8,30	10	89	49	35	40	M1703-0830AE	30141174
8,40	10	89	49	35	40	M1703-0840AE	30141175
8,50	10	89	49	35	40	M1703-0850AE	30059031
8,60	10	89	49	35	40	M1703-0860AE	30099758
8,70	10	89	49	35	40	M1703-0870AE	30059034
8,80	10	89	49	35	40	M1703-0880AE	30141176
8,90	10	89	49	35	40	M1703-0890AE	30137106
9,00	10	89	49	35	40	M1703-0900AE	30059036
9,10	10	89	49	35	40	M1703-0910AE	30141177
9,50	10	89	49	35	40	M1703-0950AE	30098249
9,80	10	89	49	35	40	M1703-0980AE	30141181
9,90	10	89	49	35	40	M1703-0990AE	30141182
10,00	10	89	49	35	40	M1703-1000AE	30075973
10,10	12	102	56	40	45	M1703-1010AE	30141183
10,20	12	102	56	40	45	M1703-1020AE	30059042
10,30	12	102	56	40	45	M1703-1030AE	30099759
10,50	12	102	56	40	45	M1703-1050AE	30073328
11,00	12	102	56	40	45	M1703-1100AE	30079522
11,50	12	102	56	40	45	M1703-1150AE	30059052



**MEGA-Drill-Inox | Vollhartmetall-Spiralbohrer M1703 (3xD), äußere Kühlmittelzufuhr**

Baumaße						Schaftform HA	
d <sub>1</sub> m7	d <sub>2</sub> h6	l <sub>1</sub>	l <sub>2</sub>	l <sub>3</sub>	l <sub>4</sub>	Spezifikation	Bestell-Nr.
11,80	12	102	56	40	45	M1703-1180AE	30141193
12,00	12	102	56	40	45	M1703-1200AE	30059056
12,15	14	107	61	43	45	M1703-1215AE	30322796
12,50	14	107	61	43	45	M1703-1250AE	30141195
12,80	14	107	61	43	45	M1703-1280AE	30141196
13,00	14	107	61	43	45	M1703-1300AE	30141197
13,80	14	107	61	43	45	M1703-1380AE	30141198
14,00	14	107	61	43	45	M1703-1400AE	30088983
15,00	16	115	65	45	48	M1703-1500AE	30141201
16,00	16	115	65	45	48	M1703-1600AE	30141204
17,00	18	123	73	51	48	M1703-1700AE	30141206
18,00	18	123	73	51	48	M1703-1800AE	30141208
19,00	20	131	79	55	50	M1703-1900AE	30141211

**Konfigurierbare Merkmale**

**Durchmesser:**  
Durchmesser in Abstufungen  
von 0,01 mm frei wählbar



**Schaftform:**  
Schaftform: HB | HE

**Spezifikation:**

M1703-[Durchmesser][Schaftform]E

**Beispiel:**  
M1703-0431EE

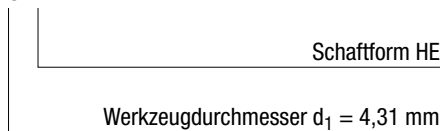
**Abmessungen konfigurierbare Baureihe**

d <sub>1</sub> min.	d <sub>1</sub> max.	d <sub>2</sub> h6	l <sub>1</sub>	l <sub>2</sub>	l <sub>3</sub>	l <sub>4</sub>
3,00	3,70	6	62	22	14	36
3,71	4,70	6	66	26	17	36
4,71	6,00	6	66	30	20	36
6,01	7,00	8	79	38	24	36
7,01	8,00	8	79	42	29	36
8,01	10,00	10	89	49	35	40
10,01	12,00	12	102	56	40	45
12,01	14,00	14	107	61	43	45
14,01	16,00	16	115	65	45	48
16,01	18,00	18	123	73	51	48
18,01	20,00	20	131	79	55	50

Maßangaben in mm.

Schnittwertempfehlung siehe Kapitelende.

Sonderausführungen und andere Beschichtungen auf Anfrage.

# MEGA-Drill-Inox

Vollhartmetall-Spiralbohrer  
M1803 (3xD), innere Kühlmittelzufuhr

## Ausführung:

Bohrerdurchmesser: 3,00 - 20,00 mm  
Bohrungstoleranz:  $\geq$  IT 9  
Beschichtung: MxF  
Schneidenanzahl: 2  
Anzahl Führungsfasen: 2  
Spitzenwinkel:  $140^\circ$   
Spiralwinkel:  $30^\circ$

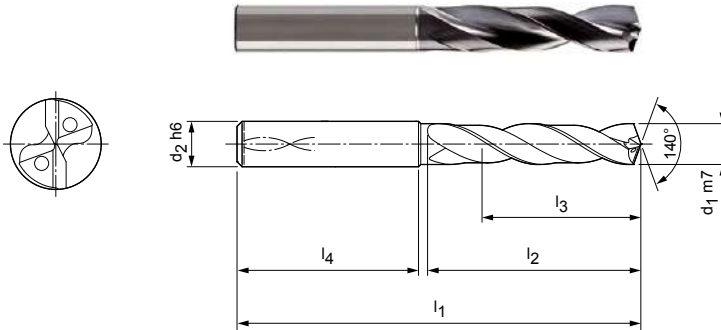

## Lagerhaltige Vorzugsbaureihe in Schaftform HA

Baumaße						Schaftform HA	
d <sub>1</sub> m7	d <sub>2</sub> h6	l <sub>1</sub>	l <sub>2</sub>	l <sub>3</sub>	l <sub>4</sub>	Spezifikation	Bestell-Nr.
3,00	6	62	22	14	36	M1803-0300AE	30059162
3,05	6	62	22	14	36	M1803-0305AE	30137924
3,15	6	62	22	14	36	M1803-0315AE	30322808
3,20	6	62	22	14	36	M1803-0320AE	30059165
3,25	6	62	22	14	36	M1803-0325AE	30322810
3,30	6	62	22	14	36	M1803-0330AE	30072646
3,40	6	62	22	14	36	M1803-0340AE	30099780
3,50	6	62	22	14	36	M1803-0350AE	30072069
3,60	6	62	22	14	36	M1803-0360AE	30059167
3,70	6	62	22	14	36	M1803-0370AE	30099781
3,80	6	66	26	17	36	M1803-0380AE	30095300
3,90	6	66	26	17	36	M1803-0390AE	30091067
4,00	6	66	26	17	36	M1803-0400AE	30072091
4,10	6	66	26	17	36	M1803-0410AE	30078059
4,20	6	66	26	17	36	M1803-0420AE	30073332
4,30	6	66	26	17	36	M1803-0430AE	30062408
4,35	6	66	26	17	36	M1803-0435AE	30322812
4,40	6	66	26	17	36	M1803-0440AE	30059173
4,50	6	66	26	17	36	M1803-0450AE	30073381
4,65	6	66	26	17	36	M1803-0465AE	30139997
4,70	6	66	26	17	36	M1803-0470AE	30059176
4,80	6	66	30	20	36	M1803-0480AE	30099221
5,00	6	66	30	20	36	M1803-0500AE	30072778
5,10	6	66	30	20	36	M1803-0510AE	30072248
5,20	6	66	30	20	36	M1803-0520AE	30059180
5,30	6	66	30	20	36	M1803-0530AE	30059181
5,40	6	66	30	20	36	M1803-0540AE	30059182
5,50	6	66	30	20	36	M1803-0550AE	30079530
5,55	6	66	30	20	36	M1803-0555AE	30139998
5,60	6	66	30	20	36	M1803-0560AE	30059183
5,70	6	66	30	20	36	M1803-0570AE	30141274
5,80	6	66	30	20	36	M1803-0580AE	30059186
5,90	6	66	30	20	36	M1803-0590AE	30099223
5,95	6	66	30	20	36	M1803-0595AE	30322817
6,00	6	66	30	20	36	M1803-0600AE	30059189

## MEGA-Drill-Inox | Vollhartmetall-Spiralbohrer M1803 (3xD), innere Kühlmittelzufuhr

Baumaße						Schaftform HA	
d <sub>1</sub> m7	d <sub>2</sub> h6	l <sub>1</sub>	l <sub>2</sub>	l <sub>3</sub>	l <sub>4</sub>	Spezifikation	Bestell-Nr.
6,10	8	79	38	24	36	M1803-0610AE	30118134
6,20	8	79	38	24	36	M1803-0620AE	30139995
6,30	8	79	38	24	36	M1803-0630AE	30062430
6,40	8	79	38	24	36	M1803-0640AE	30139996
6,50	8	79	38	24	36	M1803-0650AE	30059192
6,60	8	79	38	24	36	M1803-0660AE	30062439
6,70	8	79	38	24	36	M1803-0670AE	30085029
6,80	8	79	38	24	36	M1803-0680AE	30062431
6,90	8	79	38	24	36	M1803-0690AE	30059195
7,00	8	79	38	24	36	M1803-0700AE	30059196
7,10	8	79	42	29	36	M1803-0710AE	30077660
7,20	8	79	42	29	36	M1803-0720AE	30072833
7,30	8	79	42	29	36	M1803-0730AE	30141275
7,40	8	79	42	29	36	M1803-0740AE	30078210
7,45	8	79	42	29	36	M1803-0745AE	30322818
7,50	8	79	42	29	36	M1803-0750AE	30094019
7,70	8	79	42	29	36	M1803-0770AE	30073042
7,80	8	79	42	29	36	M1803-0780AE	30141276
7,90	8	79	42	29	36	M1803-0790AE	30059203
8,00	8	79	42	29	36	M1803-0800AE	30072260
8,10	10	89	49	35	40	M1803-0810AE	30059204
8,20	10	89	49	35	40	M1803-0820AE	30075971
8,30	10	89	49	35	40	M1803-0830AE	30090518
8,40	10	89	49	35	40	M1803-0840AE	30093399
8,50	10	89	49	35	40	M1803-0850AE	30059206
8,60	10	89	49	35	40	M1803-0860AE	30062441
8,70	10	89	49	35	40	M1803-0870AE	30059209
8,80	10	89	49	35	40	M1803-0880AE	30079075
9,00	10	89	49	35	40	M1803-0900AE	30059211
9,10	10	89	49	35	40	M1803-0910AE	30059212
9,20	10	89	49	35	40	M1803-0920AE	30079769
9,30	10	89	49	35	40	M1803-0930AE	30073335
9,35	10	89	49	35	40	M1803-0935AE	30322819
9,40	10	89	49	35	40	M1803-0940AE	30141277
9,50	10	89	49	35	40	M1803-0950AE	30059214
9,70	10	89	49	35	40	M1803-0970AE	30078076
9,80	10	89	49	35	40	M1803-0980AE	30141278
9,90	10	89	49	35	40	M1803-0990AE	30141279
10,00	10	89	49	35	40	M1803-1000AE	30095228
10,20	12	102	56	40	45	M1803-1020AE	30079770
10,30	12	102	56	40	45	M1803-1030AE	30059222
10,40	12	102	56	40	45	M1803-1040AE	30073422
10,50	12	102	56	40	45	M1803-1050AE	30059225
10,70	12	102	56	40	45	M1803-1070AE	30141280
10,80	12	102	56	40	45	M1803-1080AE	30078099
11,00	12	102	56	40	45	M1803-1100AE	30059229
11,10	12	102	56	40	45	M1803-1110AE	30075367
11,30	12	102	56	40	45	M1803-1130AE	30077777
11,50	12	102	56	40	45	M1803-1150AE	30072039
11,70	12	102	56	40	45	M1803-1170AE	30075802
11,80	12	102	56	40	45	M1803-1180AE	30059236
12,00	12	102	56	40	45	M1803-1200AE	30080709
12,15	14	107	61	43	45	M1803-1215AE	30322825
12,50	14	107	61	43	45	M1803-1250AE	30073336
12,80	14	107	61	43	45	M1803-1280AE	30141284
13,00	14	107	61	43	45	M1803-1300AE	30075996
13,50	14	107	61	43	45	M1803-1350AE	30075974

Fortsetzung auf nächster Seite.

**MEGA-Drill-Inox | Vollhartmetall-Spiralbohrer M1803 (3xD), innere Kühlmittelzufuhr**

Baumaße						Schaffform HA	
d <sub>1</sub> m7	d <sub>2</sub> h6	l <sub>1</sub>	l <sub>2</sub>	l <sub>3</sub>	l <sub>4</sub>	Spezifikation	Bestell-Nr.
13,80	14	107	61	43	45	M1803-1380AE	30141285
14,00	14	107	61	43	45	M1803-1400AE	30080341
14,50	16	115	65	45	48	M1803-1450AE	30072340
15,00	16	115	65	45	48	M1803-1500AE	30059246
15,50	16	115	65	45	48	M1803-1550AE	30059249
15,80	16	115	65	45	48	M1803-1580AE	30141287
16,00	16	115	65	45	48	M1803-1600AE	30085045
17,50	18	123	73	51	48	M1803-1750AE	30078812
18,00	18	123	73	51	48	M1803-1800AE	30080710
20,00	20	131	79	55	50	M1803-2000AE	30118133

**Konfigurierbare Merkmale**



**Durchmesser:**  
Durchmesser in Abstufungen von 0,01 mm frei wählbar



**Schaffform:**  
Schaffform: HB | HE

**Spezifikation:**  
M1803-[Durchmesser][Schaffform]E

**Abmessungen konfigurierbare Baureihe**

d <sub>1</sub> min.	d <sub>1</sub> max.	d <sub>2</sub> h6	l <sub>1</sub>	l <sub>2</sub>	l <sub>3</sub>	l <sub>4</sub>
3,71	4,70	6	66	26	17	36
4,71	6,00	6	66	30	20	36
6,01	7,00	8	79	38	24	36
7,01	8,00	8	79	42	29	36
8,01	10,00	10	89	49	35	40
10,01	12,00	12	102	56	40	45
12,01	14,00	14	107	61	43	45
14,01	16,00	16	115	65	45	48
16,01	18,00	18	123	73	51	48
18,01	20,00	20	131	79	55	50

**Beispiel:**  
M1803-0431EE

Maßangaben in mm.  
Schnittwertempfehlung siehe Kapitelende.  
Sonderausführungen und andere Beschichtungen auf Anfrage.

# MEGA-Drill-Inox

Vollhartmetall-Spiralbohrer  
M1705 (5xD), äußere Kühlmittelzufuhr

**Ausführung:**

Bohrerdurchmesser: 3,00 - 20,00 mm  
Bohrungstoleranz:  $\geq$  IT 9  
Beschichtung: MxF  
Schneidenanzahl: 2  
Anzahl Führungsfasen: 2  
Spitzenwinkel: 140°  
Spiralwinkel: 30°

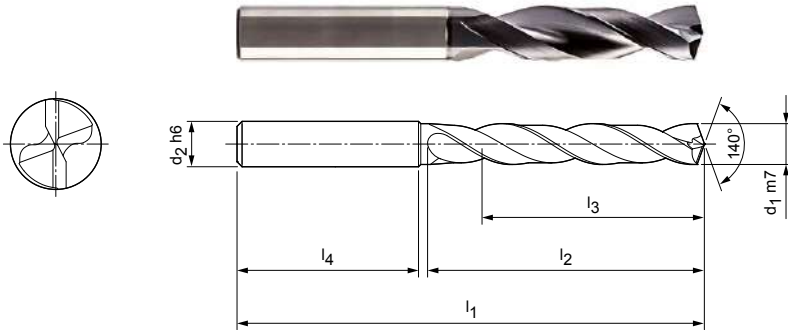

**Lagerhaltige Vorzugsbaureihe in Schaftform HA**

Baumaße						Schaftform HA	
d <sub>1</sub> m7	d <sub>2</sub> h6	l <sub>1</sub>	l <sub>2</sub>	l <sub>3</sub>	l <sub>4</sub>	Spezifikation	Bestell-Nr.
3,00	6	66	28	23	36	M1705-0300AE	30078093
3,10	6	66	28	23	36	M1705-0310AE	30141214
3,20	6	66	28	23	36	M1705-0320AE	30141215
3,30	6	66	28	23	36	M1705-0330AE	30098247
3,40	6	66	28	23	36	M1705-0340AE	30059082
3,50	6	66	28	23	36	M1705-0350AE	30079743
3,60	6	66	28	23	36	M1705-0360AE	30133970
3,70	6	66	28	23	36	M1705-0370AE	30075110
3,80	6	74	36	29	36	M1705-0380AE	30059087
3,90	6	74	36	29	36	M1705-0390AE	30059089
4,00	6	74	36	29	36	M1705-0400AE	30085517
4,10	6	74	36	29	36	M1705-0410AE	30136747
4,20	6	74	36	29	36	M1705-0420AE	30073330
4,30	6	74	36	29	36	M1705-0430AE	30099782
4,40	6	74	36	29	36	M1705-0440AE	30141216
4,50	6	74	36	29	36	M1705-0450AE	30078058
4,60	6	74	36	29	36	M1705-0460AE	30075111
4,70	6	74	36	29	36	M1705-0470AE	30133971
4,80	6	82	44	35	36	M1705-0480AE	30141217
4,90	6	82	44	35	36	M1705-0490AE	30059096
5,00	6	82	44	35	36	M1705-0500AE	30059097
5,10	6	82	44	35	36	M1705-0510AE	30062391
5,20	6	82	44	35	36	M1705-0520AE	30079744
5,30	6	82	44	35	36	M1705-0530AE	30059098
5,40	6	82	44	35	36	M1705-0540AE	30141218
5,50	6	82	44	35	36	M1705-0550AE	30059100
5,60	6	82	44	35	36	M1705-0560AE	30141219
5,80	6	82	44	35	36	M1705-0580AE	30059103
6,00	6	82	44	35	36	M1705-0600AE	30059105
6,10	8	91	53	43	36	M1705-0610AE	30059106
6,20	8	91	53	43	36	M1705-0620AE	30141222
6,30	8	91	53	43	36	M1705-0630AE	30141223
6,40	8	91	53	43	36	M1705-0640AE	30141224
6,50	8	91	53	43	36	M1705-0650AE	30080707
6,60	8	91	53	43	36	M1705-0660AE	30074660

## MEGA-Drill-Inox | Vollhartmetall-Spiralbohrer M1705 (5xD), äußere Kühlmittelzufuhr

Baumaße						Schaftform HA	
d <sub>1</sub> m7	d <sub>2</sub> h6	l <sub>1</sub>	l <sub>2</sub>	l <sub>3</sub>	l <sub>4</sub>	Spezifikation	Bestell-Nr.
6,70	8	91	53	43	36	M1705-0670AE	30141225
6,80	8	91	53	43	36	M1705-0680AE	30059110
6,90	8	91	53	43	36	M1705-0690AE	30059112
7,00	8	91	53	43	36	M1705-0700AE	30077784
7,10	8	91	53	43	36	M1705-0710AE	30141226
7,40	8	91	53	43	36	M1705-0740AE	30099783
7,50	8	91	53	43	36	M1705-0750AE	30098260
7,60	8	91	53	43	36	M1705-0760AE	30141229
7,80	8	91	53	43	36	M1705-0780AE	30091590
7,90	8	91	53	43	36	M1705-0790AE	30091591
8,00	8	91	53	43	36	M1705-0800AE	30098261
8,10	10	103	61	49	40	M1705-0810AE	30141231
8,20	10	103	61	49	40	M1705-0820AE	30141232
8,50	10	103	61	49	40	M1705-0850AE	30079078
8,60	10	103	61	49	40	M1705-0860AE	30099785
8,70	10	103	61	49	40	M1705-0870AE	30141235
8,80	10	103	61	49	40	M1705-0880AE	30141236
9,00	10	103	61	49	40	M1705-0900AE	30059127
9,20	10	103	61	49	40	M1705-0920AE	30141239
9,30	10	103	61	49	40	M1705-0930AE	30099786
9,40	10	103	61	49	40	M1705-0940AE	30141240
9,50	10	103	61	49	40	M1705-0950AE	30098262
10,00	10	103	61	49	40	M1705-1000AE	30098263
10,20	12	118	71	56	45	M1705-1020AE	30098264
10,30	12	118	71	56	45	M1705-1030AE	30099787
10,50	12	118	71	56	45	M1705-1050AE	30098265
10,80	12	118	71	56	45	M1705-1080AE	30141248
11,00	12	118	71	56	45	M1705-1100AE	30098266
11,70	12	118	71	56	45	M1705-1170AE	30141255
11,80	12	118	71	56	45	M1705-1180AE	30141256
12,00	12	118	71	56	45	M1705-1200AE	30098268
12,50	14	124	77	60	45	M1705-1250AE	30137585
13,00	14	124	77	60	45	M1705-1300AE	30089461
16,00	16	133	83	63	48	M1705-1600AE	30141262
16,50	18	143	93	71	48	M1705-1650AE	30141263

## Konfigurierbare Merkmale



**Durchmesser:**  
Durchmesser in Abstufungen  
von 0,01 mm frei wählbar



**Schaftform:**  
Schaftform: HB | HE

## Spezifikation:

M1705-[Durchmesser][Schaftform]E

## Abmessungen konfigurierbare Baureihe

d <sub>1</sub> min.	d <sub>1</sub> max.	d <sub>2</sub> h6	l <sub>1</sub>	l <sub>2</sub>	l <sub>3</sub>	l <sub>4</sub>
3,00	3,70	6	66	66	23	36
3,71	4,70	6	74	74	29	36
4,71	6,00	6	82	44	35	36
6,01	8,00	8	91	53	43	36
8,01	10,00	10	103	61	49	40
10,01	12,00	12	118	71	56	45
12,01	14,00	14	124	77	60	45
14,01	16,00	16	133	83	63	48
16,01	18,00	18	143	93	71	48
18,01	20,00	20	153	101	77	50

**Beispiel:**  
M1705-0431EE

Schaftform HE

Werkzeugdurchmesser d<sub>1</sub> = 4,31 mm

Maßangaben in mm.

Schnittwertempfehlung siehe Kapitelende.

Sonderausführungen und andere Beschichtungen auf Anfrage.

# MEGA-Drill-Inox

Vollhartmetall-Spiralbohrer  
M1805 (5xD), innere Kühlmittelzufuhr

**Ausführung:**

Bohrerdurchmesser: 2,80 - 20,00 mm  
Bohrungstoleranz:  $\geq$  IT 9  
Beschichtung: MxF  
Schneidenanzahl: 2  
Anzahl Führungsfasen: 2  
Spitzenwinkel: 140°  
Spiralwinkel: 30°

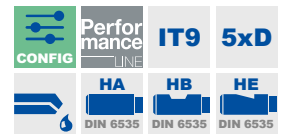
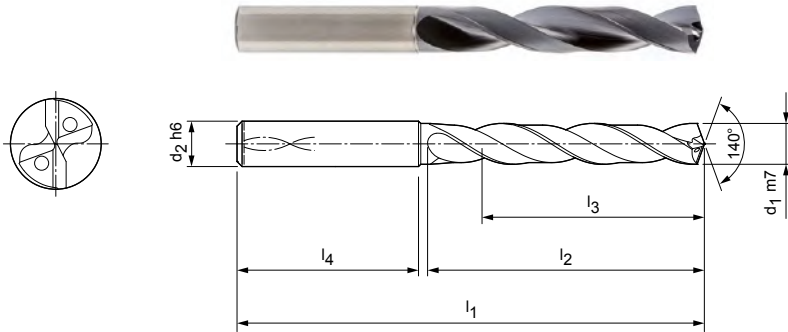

**Lagerhaltige Vorzugsbaureihe in Schaftform HA**

Baumaße						Schaftform HA	
d <sub>1</sub> m7	d <sub>2</sub> h6	l <sub>1</sub>	l <sub>2</sub>	l <sub>3</sub>	l <sub>4</sub>	Spezifikation	Bestell-Nr.
2,80	6	66	28	23	36	M1805-0280AE	30378652
3,00	6	66	28	23	36	M1805-0300AE	30059273
3,10	6	66	28	23	36	M1805-0310AE	30074862
3,15	6	66	28	23	36	M1805-0315AE	30322833
3,20	6	66	28	23	36	M1805-0320AE	30075692
3,22	6	66	28	23	36	M1805-0322AE	30322836
3,25	6	66	28	23	36	M1805-0325AE	30322837
3,30	6	66	28	23	36	M1805-0330AE	30059277
3,40	6	66	28	23	36	M1805-0340AE	30074801
3,50	6	66	28	23	36	M1805-0350AE	30059278
3,60	6	66	28	23	36	M1805-0360AE	30059279
3,70*	6	66	28	23	36	M1805-0370AE	30074807
3,80	6	74	36	29	36	M1805-0380AE	30073337
3,90	6	74	36	29	36	M1805-0390AE	30073338
4,00	6	74	36	29	36	M1805-0400AE	30074819
4,10	6	74	36	29	36	M1805-0410AE	30074863
4,15	6	74	36	29	36	M1805-0415AE	30393896
4,20	6	74	36	29	36	M1805-0420AE	30059280
4,30	6	74	36	29	36	M1805-0430AE	30074864
4,40	6	74	36	29	36	M1805-0440AE	30074814
4,45	6	74	36	29	36	M1805-0445AE	30322841
4,50	6	74	36	29	36	M1805-0450AE	30059281
4,60	6	74	36	29	36	M1805-0460AE	30074813
4,65*	6	74	36	29	36	M1805-0465AE	30322842
4,70	6	74	36	29	36	M1805-0470AE	30059283
4,80	6	82	44	35	36	M1805-0480AE	30062471
4,90	6	82	44	35	36	M1805-0490AE	30062489
5,00	6	82	44	35	36	M1805-0500AE	30062490
5,10	6	82	44	35	36	M1805-0510AE	30073340
5,20	6	82	44	35	36	M1805-0520AE	30062491
5,30	6	82	44	35	36	M1805-0530AE	30074865
5,40	6	82	44	35	36	M1805-0540AE	30073341
5,50	6	82	44	35	36	M1805-0550AE	30059287
5,60	6	82	44	35	36	M1805-0560AE	30059289
5,70	6	82	44	35	36	M1805-0570AE	30059290

## MEGA-Drill-Inox | Vollhartmetall-Spiralbohrer M1805 (5xD), innere Kühlmittelzufuhr

Baumaße						Schaftform HA	
d <sub>1</sub> m7	d <sub>2</sub> h6	l <sub>1</sub>	l <sub>2</sub>	l <sub>3</sub>	l <sub>4</sub>	Spezifikation	Bestell-Nr.
5,80	6	82	44	35	36	M1805-0580AE	30074844
5,90	6	82	44	35	36	M1805-0590AE	30074866
5,95	6	82	44	35	36	M1805-0595AE	30322844
6,00	6	82	44	35	36	M1805-0600AE	30064179
6,10	8	91	53	43	36	M1805-0610AE	30062473
6,20	8	91	53	43	36	M1805-0620AE	30062474
6,30	8	91	53	43	36	M1805-0630AE	30062475
6,40	8	91	53	43	36	M1805-0640AE	30062497
6,50	8	91	53	43	36	M1805-0650AE	30073342
6,60	8	91	53	43	36	M1805-0660AE	30074662
6,70	8	91	53	43	36	M1805-0670AE	30075693
6,80	8	91	53	43	36	M1805-0680AE	30059297
6,90	8	91	53	43	36	M1805-0690AE	30074867
7,00	8	91	53	43	36	M1805-0700AE	30059298
7,10	8	91	53	43	36	M1805-0710AE	30075694
7,20	8	91	53	43	36	M1805-0720AE	30075695
7,30	8	91	53	43	36	M1805-0730AE	30062502
7,40	8	91	53	43	36	M1805-0740AE	30075696
7,45*	8	91	53	43	36	M1805-0745AE	30322845
7,50	8	91	53	43	36	M1805-0750AE	30062478
7,60	8	91	53	43	36	M1805-0760AE	30062479
7,70	8	91	53	43	36	M1805-0770AE	30062480
7,80	8	91	53	43	36	M1805-0780AE	30059305
8,00	8	91	53	43	36	M1805-0800AE	30073346
8,10	10	103	61	49	40	M1805-0810AE	30059310
8,20	10	103	61	49	40	M1805-0820AE	30062508
8,30	10	103	61	49	40	M1805-0830AE	30075697
8,50	10	103	61	49	40	M1805-0850AE	30062481
8,60	10	103	61	49	40	M1805-0860AE	30074802
8,70	10	103	61	49	40	M1805-0870AE	30059315
8,80	10	103	61	49	40	M1805-0880AE	30075698
8,90	10	103	61	49	40	M1805-0890AE	30075699
9,00	10	103	61	49	40	M1805-0900AE	30073347
9,10	10	103	61	49	40	M1805-0910AE	30075700
9,35	10	103	61	49	40	M1805-0935AE	30322846
9,40	10	103	61	49	40	M1805-0940AE	30062514
9,45	10	103	61	49	40	M1805-0945AE	30322847
9,50	10	103	61	49	40	M1805-0950AE	30059322
9,80	10	103	61	49	40	M1805-0980AE	30074767
9,90	10	103	61	49	40	M1805-0990AE	30059323
10,00	10	103	61	49	40	M1805-1000AE	30074768
10,20	12	118	71	56	45	M1805-1020AE	30074910
10,30	12	118	71	56	45	M1805-1030AE	30059324
10,50	12	118	71	56	45	M1805-1050AE	30059327
10,55	12	118	71	56	45	M1805-1055AE	30322862
10,80	12	118	71	56	45	M1805-1080AE	30074913
11,00	12	118	71	56	45	M1805-1100AE	30059330
11,20*	12	118	71	56	45	M1805-1120AE	30074915
11,25	12	118	71	56	45	M1805-1125AE	30322863
11,30	12	118	71	56	45	M1805-1130AE	30073349
11,50	12	118	71	56	45	M1805-1150AE	30074917
11,70	12	118	71	56	45	M1805-1170AE	30073351
11,80	12	118	71	56	45	M1805-1180AE	30073352
12,00	12	118	71	56	45	M1805-1200AE	30059337
12,50	14	124	77	60	45	M1805-1250AE	30075702
13,00	14	124	77	60	45	M1805-1300AE	30059343
13,50	14	124	77	60	45	M1805-1350AE	30073353



## MEGA-Drill-Inox | Vollhartmetall-Spiralbohrer M1805 (5xD), innere Kühlmittelzufuhr

Baumaße						Schaftform HA	
d <sub>1</sub> m7	d <sub>2</sub> h6	l <sub>1</sub>	l <sub>2</sub>	l <sub>3</sub>	l <sub>4</sub>	Spezifikation	Bestell-Nr.
13,80	14	124	77	60	45	M1805-1380AE	30074918
14,00	14	124	77	60	45	M1805-1400AE	30074919
15,00	16	133	83	63	48	M1805-1500AE	30074835
16,00	16	133	83	63	48	M1805-1600AE	30074923
16,50	18	143	93	71	48	M1805-1650AE	30074924
17,00	18	143	93	71	48	M1805-1700AE	30074926
18,00	18	143	93	71	48	M1805-1800AE	30074831
20,00	20	153	101	77	50	M1805-2000AE	30074941

## Konfigurierbare Merkmale



**Durchmesser:**  
Durchmesser in Abstufungen  
von 0,01 mm frei wählbar



**Schaftform:**  
Schaftform: HB | HE

**Spezifikation:**

M1805-[Durchmesser][Schaftform]E

## Abmessungen konfigurierbare Baureihe

d <sub>1</sub> min.	d <sub>1</sub> max.	d <sub>2</sub> h6	l <sub>1</sub>	l <sub>2</sub>	l <sub>3</sub>	l <sub>4</sub>
3,71	4,70	6	74	36	29	36
4,71	6,00	6	82	44	35	36
6,01	8,00	8	91	53	43	36
8,01	10,00	10	103	61	49	40
10,01	12,00	12	118	71	56	45
12,01	14,00	14	124	77	60	45
14,01	16,00	16	133	83	63	45
16,01	18,00	18	143	93	71	48
18,01	20,00	20	153	101	77	50

**Beispiel:**  
M1805-0431EE

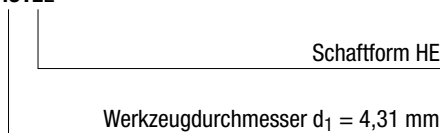

Maßangaben in mm.

\* Speziell zur Vorfertigung der Kernlöcher für Gewindeformer geeignet.

Schnittwertempfehlung siehe Kapitelende.

Sonderausführungen und andere Beschichtungen auf Anfrage.

# MEGA-Drill-Inox

Vollhartmetall-Spiralbohrer  
M1808 (8xD), innere Kühlmittelzufuhr

## Ausführung:

Bohrerdurchmesser: 3,00 - 20,00 mm  
Bohrungstoleranz:  $\geq$  IT 9  
Beschichtung: MxF  
Schneidenanzahl: 2  
Anzahl Führungsfasen: 2  
Spitzenwinkel: 140°  
Spiralwinkel: 30°

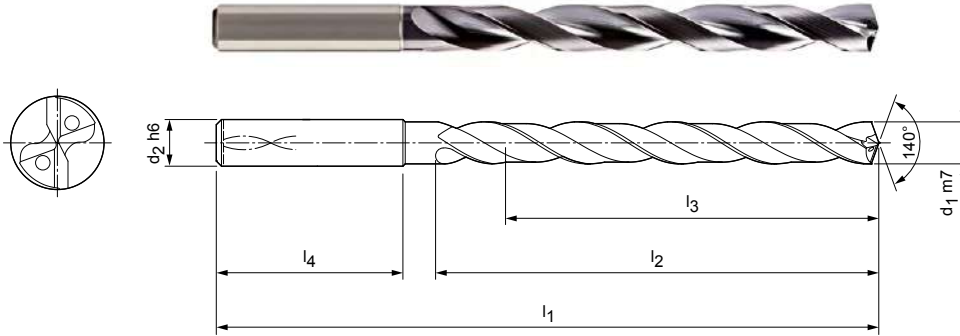

## Lagerhaltige Vorzugsbaureihe in Schaftform HA

Baumaße						Schaftform HA	
d <sub>1</sub> m7	d <sub>2</sub> h6	l <sub>1</sub>	l <sub>2</sub>	l <sub>3</sub>	l <sub>4</sub>	Spezifikation	Bestell-Nr.
3,00	6	72	34	29	36	M1808-0300AE	30214840
3,20	6	72	34	29	36	M1808-0320AE	30211908
3,30	6	72	34	29	36	M1808-0330AE	30091668
3,40	6	72	34	29	36	M1808-0340AE	30229435
3,50	6	72	34	29	36	M1808-0350AE	30229436
3,70	6	72	34	29	36	M1808-0370AE	30229438
3,80	6	81	43	36	36	M1808-0380AE	30229439
3,90	6	81	43	36	36	M1808-0390AE	30229441
4,00	6	81	43	36	36	M1808-0400AE	30072862
4,20	6	81	43	36	36	M1808-0420AE	30081828
4,30	6	81	43	36	36	M1808-0430AE	30229442
4,40	6	81	43	36	36	M1808-0440AE	30086811
4,50	6	81	43	36	36	M1808-0450AE	30214841
4,80	6	95	57	48	36	M1808-0480AE	30190439
4,90	6	95	57	48	36	M1808-0490AE	30072966
5,00	6	95	57	48	36	M1808-0500AE	30214847
5,10	6	95	57	48	36	M1808-0510AE	30229462
5,30	6	95	57	48	36	M1808-0530AE	30229465
5,50	6	95	57	48	36	M1808-0550AE	30073397
5,60	6	95	57	48	36	M1808-0560AE	30229467
5,80	6	95	57	48	36	M1808-0580AE	30204864
5,90	6	95	57	48	36	M1808-0590AE	30229470
6,00	6	95	57	48	36	M1808-0600AE	30214848
6,10	8	114	76	64	36	M1808-0610AE	30229485
6,50	8	114	76	64	36	M1808-0650AE	30073396
6,60	8	114	76	64	36	M1808-0660AE	30229490
6,70	8	114	76	64	36	M1808-0670AE	30229491
6,80	8	114	76	64	36	M1808-0680AE	30229492
6,90	8	114	76	64	36	M1808-0690AE	30229493
7,00	8	114	76	64	36	M1808-0700AE	30214846
7,20	8	114	76	64	36	M1808-0720AE	30229496
7,50	8	114	76	64	36	M1808-0750AE	30229499
7,60	8	114	76	64	36	M1808-0760AE	30229500
7,80	8	114	76	64	36	M1808-0780AE	30229503
8,00	8	114	76	64	36	M1808-0800AE	30214845

## MEGA-Drill-Inox | Vollhartmetall-Spiralbohrer M1808 (8xD), innere Kühlmittelzufuhr

Baumaße						Schaffform HA	
d <sub>1</sub> m7	d <sub>2</sub> h6	l <sub>1</sub>	l <sub>2</sub>	l <sub>3</sub>	l <sub>4</sub>	Spezifikation	Bestell-Nr.
8,50	10	142	95	80	40	M1808-0850AE	30204865
8,90	10	142	95	80	40	M1808-0890AE	30072769
9,00	10	142	95	80	40	M1808-0900AE	30063972
9,10	10	142	95	80	40	M1808-0910AE	30229447
9,30	10	142	95	80	40	M1808-0930AE	30229450
9,50	10	142	95	80	40	M1808-0950AE	30229454
9,60	10	142	95	80	40	M1808-0960AE	30229457
9,70	10	142	95	80	40	M1808-0970AE	30229458
9,80	10	142	95	80	40	M1808-0980AE	30229459
10,00	10	142	95	80	40	M1808-1000AE	30179572
10,10	12	162	114	96	45	M1808-1010AE	30229472
10,20	12	162	114	96	45	M1808-1020AE	30214844
10,80	12	162	114	96	45	M1808-1080AE	30229488
11,00	12	162	114	96	45	M1808-1100AE	30214843
11,50	12	162	114	96	45	M1808-1150AE	30229512
11,80	12	162	114	96	45	M1808-1180AE	30229536
12,00	12	162	114	96	45	M1808-1200AE	30214842
13,00	14	178	133	112	45	M1808-1300AE	30204791
13,50	14	178	133	112	45	M1808-1350AE	30229549
14,00	14	178	133	112	45	M1808-1400AE	30229553
14,50	16	203	152	128	48	M1808-1450AE	30229554
15,00	16	203	152	128	48	M1808-1500AE	30229558
18,00	18	222	171	144	48	M1808-1800AE	30229572

## Konfigurierbare Merkmale

**Durchmesser:**

Durchmesser in Abstufungen  
von 0,01 mm frei wählbar

**Schaffform:**

Schaffform: HB | HE

**Spezifikation:**

M1808-[Durchmesser][Schaffform]E

## Abmessungen konfigurierbare Baureihe

d <sub>1</sub> min.	d <sub>1</sub> max.	d <sub>2</sub> h6	l <sub>1</sub>	l <sub>2</sub>	l <sub>3</sub>	l <sub>4</sub>
3,71	4,70	6	81	43	36	36
4,71	6,00	6	95	57	48	36
6,01	8,00	8	114	76	64	36
8,01	10,00	10	142	95	80	40
10,01	12,00	12	162	114	96	45
12,01	14,00	14	178	133	112	45
14,01	16,00	16	203	152	128	48
16,01	18,00	18	222	171	144	48
18,01	20,00	20	243	190	160	50

Beispiel:  
M1808-0431EE

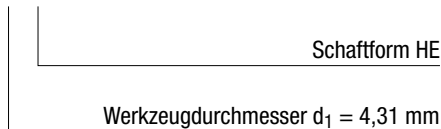

Maßangaben in mm.

Schnittwertempfehlung siehe Kapitelende.

Sonderausführungen und andere Beschichtungen auf Anfrage.

# MEGA-Speed-Drill-Inox

Vollhartmetall-Spiralbohrer  
M9405 (5xD) innere Kühlmittelzufuhr

**Ausführung:**  
Bohrerdurchmesser: 3,00 - 20,00 mm  
Bohrungstoleranz:  $\geq$  IT 9  
Beschichtung: Mx2  
Schneidenanzahl: 2  
Anzahl Führungsfasen: 3  
Spitzenwinkel: 135°  
Spiralwinkel: 30°

**Anwendung:**  
Für Hochgeschwindigkeitsbearbeitung.

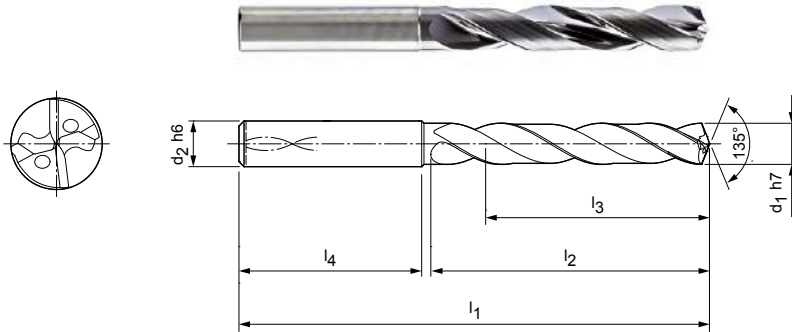

**Lagerhaltige Vorzugsbaureihe in Schaftform HA**

Baumaße						Schaftform HA	
d <sub>1</sub> h7	d <sub>2</sub> h6	l <sub>1</sub>	l <sub>2</sub>	l <sub>3</sub>	l <sub>4</sub>	Spezifikation	Bestell-Nr.
3,00	6	66	28	23	36	M9405-0300AK	30484078
3,10	6	66	28	23	36	M9405-0310AK	30484079
3,20	6	66	28	23	36	M9405-0320AK	30484080
3,30	6	66	28	23	36	M9405-0330AK	30484081
3,40	6	66	28	23	36	M9405-0340AK	30484082
3,50	6	66	28	23	36	M9405-0350AK	30484083
3,70	6	66	28	23	36	M9405-0370AK	30484085
3,80	6	74	36	29	36	M9405-0380AK	30484086
4,00	6	74	36	29	36	M9405-0400AK	30484088
4,10	6	74	36	29	36	M9405-0410AK	30484089
4,20	6	74	36	29	36	M9405-0420AK	30484090
4,30	6	74	36	29	36	M9405-0430AK	30484091
4,50	6	74	36	29	36	M9405-0450AK	30484093
4,65	6	74	36	29	36	M9405-0465AK	30484095
4,70	6	74	36	29	36	M9405-0470AK	30484096
4,80	6	82	44	35	36	M9405-0480AK	30484097
5,00	6	82	44	35	36	M9405-0500AK	30484099
5,10	6	82	44	35	36	M9405-0510AK	30484100
5,20	6	82	44	35	36	M9405-0520AK	30484101
5,30	6	82	44	35	36	M9405-0530AK	30484102
5,50	6	82	44	35	36	M9405-0550AK	30484104
5,55	6	82	44	35	36	M9405-0555AK	30484105
5,60	6	82	44	35	36	M9405-0560AK	30484106
5,80	6	82	44	35	36	M9405-0580AK	30484108
5,90	6	82	44	35	36	M9405-0590AK	30484110
6,00	6	82	44	35	36	M9405-0600AK	30484111
6,10	8	91	53	43	36	M9405-0610AK	30484112
6,30	8	91	53	43	36	M9405-0630AK	30484114
6,50	8	91	53	43	36	M9405-0650AK	30484116
6,60	8	91	53	43	36	M9405-0660AK	30484117
6,80	8	91	53	43	36	M9405-0680AK	30484119
6,90	8	91	53	43	36	M9405-0690AK	30484120
7,00	8	91	53	43	36	M9405-0700AK	30484121
7,30	8	91	53	43	36	M9405-0730AK	30484124
7,40	8	91	53	43	36	M9405-0740AK	30484125

**MEGA-Speed-Drill-Inox | Vollhartmetall-Spiralbohrer M9405 (5xD), innere Kühlmittelzufuhr**

Baumaße						Schaffform HA	
d <sub>1</sub> h7	d <sub>2</sub> h6	l <sub>1</sub>	l <sub>2</sub>	l <sub>3</sub>	l <sub>4</sub>	Spezifikation	Bestell-Nr.
7,50	8	91	53	43	36	M9405-0750AK	30484126
7,60	8	91	53	43	36	M9405-0760AK	30484127
7,80	8	91	53	43	36	M9405-0780AK	30484129
8,00	8	91	53	43	36	M9405-0800AK	30484131
8,30	10	103	61	49	40	M9405-0830AK	30484134
8,50	10	103	61	49	40	M9405-0850AK	30484136
8,60	10	103	61	49	40	M9405-0860AK	30484137
8,70	10	103	61	49	40	M9405-0870AK	30484138
8,80	10	103	61	49	40	M9405-0880AK	30484139
8,90	10	103	61	49	40	M9405-0890AK	30484140
9,00	10	103	61	49	40	M9405-0900AK	30484141
9,20	10	103	61	49	40	M9405-0920AK	30484143
9,50	10	103	61	49	40	M9405-0950AK	30484146
9,70	10	103	61	49	40	M9405-0970AK	30484148
9,80	10	103	61	49	40	M9405-0980AK	30484149
9,90	10	103	61	49	40	M9405-0990AK	30484150
10,00	10	103	61	49	40	M9405-1000AK	30484151
10,20	12	118	71	56	45	M9405-1020AK	30484153
10,30	12	118	71	56	45	M9405-1030AK	30484154
10,50	12	118	71	56	45	M9405-1050AK	30484156
10,80	12	118	71	56	45	M9405-1080AK	30484159
11,00	12	118	71	56	45	M9405-1100AK	30484161
11,50	12	118	71	56	45	M9405-1150AK	30484166
11,80	12	118	71	56	45	M9405-1180AK	30484169
12,00	12	118	71	56	45	M9405-1200AK	30484171
12,20	14	124	77	60	45	M9405-1220AK	30899104
12,50	14	124	77	60	45	M9405-1250AK	30484172
12,80	14	124	77	60	45	M9405-1280AK	30484173
13,00	14	124	77	60	45	M9405-1300AK	30484174
13,50	14	124	77	60	45	M9405-1350AK	30484175
14,00	14	124	77	60	45	M9405-1400AK	30484177
14,20	16	133	83	63	48	M9405-1420AK	30661525
14,50	16	133	83	71	48	M9405-1450AK	30484178
15,00	16	133	83	71	48	M9405-1500AK	30484180
16,00	16	133	83	71	48	M9405-1600AK	30484183
17,00	18	143	93	71	48	M9405-1700AK	30484186
17,50	18	143	93	71	48	M9405-1750AK	30484187
18,00	18	143	93	71	48	M9405-1800AK	30484189
18,50	20	153	101	77	50	M9405-1850AK	30484190
20,00	20	153	101	77	50	M9405-2000AK	30484195

Fortsetzung auf nächster Seite.

## MEGA-Speed-Drill-Inox | Vollhartmetall-Spiralbohrer M9405 (5xD), innere Kühlmittelzufuhr

## Konfigurierbare Merkmale

**Durchmesser:**

Durchmesser in Abstufungen  
von 0,01 mm frei wählbar

**Schaftform:**

Schaftform: HB | HE

**Spezifikation:**

M9405-[Durchmesser][Schaftform]K

## Abmessungen konfigurierbare Baureihe

d <sub>1</sub> min.	d <sub>1</sub> max.	d <sub>2</sub> h6	l <sub>1</sub>	l <sub>2</sub>	l <sub>3</sub>	l <sub>4</sub>
3,00	3,70	6	66	28	23	36
3,71	4,70	6	74	36	29	36
4,71	6,00	6	82	44	35	36
6,01	8,00	8	91	53	43	36
8,01	10,00	10	103	61	49	40
10,01	12,00	12	118	71	56	45
12,01	14,00	14	124	77	60	45
14,01	16,00	16	133	83	63	48
16,01	18,00	18	143	93	71	48
18,01	20,00	20	153	101	77	50

**Beispiel:**

M9405-0431EK

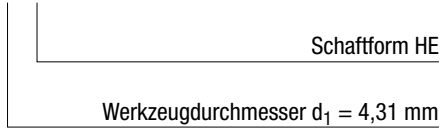

# MEGA-Speed-Drill-Inox

Vollhartmetall-Spiralbohrer  
M9408 (8xD), innere Kühlmittelzufuhr

**Ausführung:**  
Bohrerdurchmesser: 3,00 - 20,00 mm  
Bohrungstoleranz:  $\geq$  IT 9  
Beschichtung: Mx2  
Schneidenanzahl: 2  
Anzahl Führungsfasen: 3  
Spitzenwinkel: 135°  
Spiralwinkel: 30°

**Anwendung:**  
Für Hochgeschwindigkeitsbearbeitung.

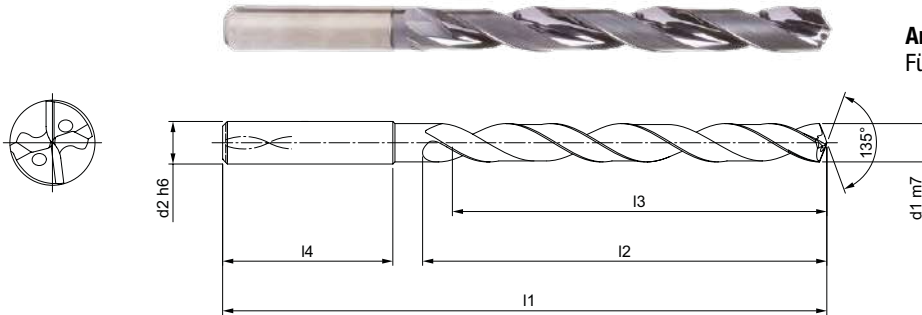

## Lagerhaltige Vorzugsbaureihe in Schaftform HA

Baumaße						Schaftform HA	
d <sub>1</sub> m7	d <sub>2</sub> h6	l <sub>1</sub>	l <sub>2</sub>	l <sub>3</sub>	l <sub>4</sub>	Spezifikation	Bestell-Nr.
3,00	6	72	34	29	36	M9408-0300AK	31159503
3,20	6	72	34	29	36	M9408-0320AK	31159505
3,30	6	72	34	29	36	M9408-0330AK	31159506
3,40	6	72	34	29	36	M9408-0340AK	31159507
3,50	6	72	34	29	36	M9408-0350AK	31159508
3,70	6	72	34	29	36	M9408-0370AK	31159530
3,90	6	81	43	36	36	M9408-0390AK	31159532
4,00	6	81	43	36	36	M9408-0400AK	31159533
4,10	6	81	43	36	36	M9408-0410AK	31159534
4,20	6	81	43	36	36	M9408-0420AK	31159535
4,30	6	81	43	36	36	M9408-0430AK	31159536
4,50	6	81	43	36	36	M9408-0450AK	31159538
4,60	6	81	43	36	36	M9408-0460AK	31159539
4,80	6	95	57	48	36	M9408-0480AK	31159542
5,00	6	95	57	48	36	M9408-0500AK	31159544
5,10	6	95	57	48	36	M9408-0510AK	31159545
5,20	6	95	57	48	36	M9408-0520AK	31159546
5,40	6	95	57	48	36	M9408-0540AK	31159548
5,50	6	95	57	48	36	M9408-0550AK	31159549
5,80	6	95	57	48	36	M9408-0580AK	31159553
6,00	6	95	57	48	36	M9408-0600AK	31159555
6,10	8	114	76	64	36	M9408-0610AK	31159556
6,50	8	114	76	64	36	M9408-0650AK	31159560
6,80	8	114	76	64	36	M9408-0680AK	31159563
7,00	8	114	76	64	36	M9408-0700AK	31159565
7,50	8	114	76	64	36	M9408-0750AK	31159570
7,80	8	114	76	64	36	M9408-0780AK	31159573
8,00	8	114	76	64	36	M9408-0800AK	31159575
8,50	10	142	95	80	40	M9408-0850AK	31159580
9,00	10	142	95	80	40	M9408-0900AK	31159585
9,30	10	142	95	80	40	M9408-0930AK	31159588
9,50	10	142	95	80	40	M9408-0950AK	31159590
9,80	10	142	95	80	40	M9408-0980AK	31159593
10,00	10	142	95	80	40	M9408-1000AK	31159595
10,20	12	162	114	96	45	M9408-1020AK	31159597

## MEGA-Speed-Drill-Inox | Vollhartmetall-Spiralbohrer M9408 (8xD), innere Kühlmittelzufuhr

Baumaße						Schaffform HA	
d <sub>1</sub> m7	d <sub>2</sub> h6	l <sub>1</sub>	l <sub>2</sub>	l <sub>3</sub>	l <sub>4</sub>	Spezifikation	Bestell-Nr.
10,50	12	162	114	96	45	M9408-1050AK	31159600
11,00	12	162	114	96	45	M9408-1100AK	31159605
11,80	12	162	114	96	45	M9408-1180AK	31159613
12,00	12	162	114	96	45	M9408-1200AK	31159615
12,50	14	178	133	112	45	M9408-1250AK	31159617
13,00	14	178	133	112	45	M9408-1300AK	31159619
13,50	14	178	133	112	45	M9408-1350AK	31159620
14,00	14	178	133	112	45	M9408-1400AK	31159622
15,00	16	203	152	128	48	M9408-1500AK	31159626
16,00	16	203	152	128	48	M9408-1600AK	31159630
7,30	8	114	76	64	36	M9408-0730AK	31159568
7,40	8	114	76	64	36	M9408-0740AK	31159569
7,50	8	114	76	64	36	M9408-0750AK	31159570
7,60	8	114	76	64	36	M9408-0760AK	31159571
7,70	8	114	76	64	36	M9408-0770AK	31159572
7,80	8	114	76	64	36	M9408-0780AK	31159573
7,90	8	114	76	64	36	M9408-0790AK	31159574
8,00	8	114	76	64	36	M9408-0800AK	31159575
8,10	10	142	95	80	40	M9408-0810AK	31159576
8,20	10	142	95	80	40	M9408-0820AK	31159577
8,30	10	142	95	80	40	M9408-0830AK	31159578
8,40	10	142	95	80	40	M9408-0840AK	31159579
8,50	10	142	95	80	40	M9408-0850AK	31159580
8,60	10	142	95	80	40	M9408-0860AK	31159581
8,70	10	142	95	80	40	M9408-0870AK	31159582
8,80	10	142	95	80	40	M9408-0880AK	31159583
8,90	10	142	95	80	40	M9408-0890AK	31159584
9,00	10	142	95	80	40	M9408-0900AK	31159585
9,10	10	142	95	80	40	M9408-0910AK	31159586
9,20	10	142	95	80	40	M9408-0920AK	31159587
9,30	10	142	95	80	40	M9408-0930AK	31159588
9,40	10	142	95	80	40	M9408-0940AK	31159589
9,50	10	142	95	80	40	M9408-0950AK	31159590
9,60	10	142	95	80	40	M9408-0960AK	31159591
9,70	10	142	95	80	40	M9408-0970AK	31159592
9,80	10	142	95	80	40	M9408-0980AK	31159593
9,90	10	142	95	80	40	M9408-0990AK	31159594
10,00	10	142	95	80	40	M9408-1000AK	31159595
10,10	12	162	114	96	45	M9408-1010AK	31159596
10,20	12	162	114	96	45	M9408-1020AK	31159597
10,30	12	162	114	96	45	M9408-1030AK	31159598
10,40	12	162	114	96	45	M9408-1040AK	31159599
10,50	12	162	114	96	45	M9408-1050AK	31159600
10,60	12	162	114	96	45	M9408-1060AK	31159601
10,70	12	162	114	96	45	M9408-1070AK	31159602
10,80	12	162	114	96	45	M9408-1080AK	31159603
10,90	12	162	114	96	45	M9408-1090AK	31159604
11,00	12	162	114	96	45	M9408-1100AK	31159605
11,10	12	162	114	96	45	M9408-1110AK	31159606
11,20	12	162	114	96	45	M9408-1120AK	31159607
11,30	12	162	114	96	45	M9408-1130AK	31159608
11,40	12	162	114	96	45	M9408-1140AK	31159609
11,50	12	162	114	96	45	M9408-1150AK	31159610
11,60	12	162	114	96	45	M9408-1160AK	31159611
11,70	12	162	114	96	45	M9408-1170AK	31159612
11,80	12	162	114	96	45	M9408-1180AK	31159613
11,90	12	162	114	96	45	M9408-1190AK	31159614



**MEGA-Speed-Drill-Inox | Vollhartmetall-Spiralbohrer M9408 (8xD), innere Kühlmittelzufuhr**

Baumaße						Schaffform HA	
d <sub>1</sub> m7	d <sub>2</sub> h6	l <sub>1</sub>	l <sub>2</sub>	l <sub>3</sub>	l <sub>4</sub>	Spezifikation	Bestell-Nr.
12,00	12	162	114	96	45	M9408-1200AK	31159615
12,20	14	178	133	112	45	M9408-1220AK	31159616
12,50	14	178	133	112	45	M9408-1250AK	31159617
12,80	14	178	133	112	45	M9408-1280AK	31159618
13,00	14	178	133	112	45	M9408-1300AK	31159619
13,50	14	178	133	112	45	M9408-1350AK	31159620
13,80	14	178	133	112	45	M9408-1380AK	31159621
14,00	14	178	133	112	45	M9408-1400AK	31159622
14,20	16	203	152	128	48	M9408-1420AK	31159623
14,50	16	203	152	128	48	M9408-1450AK	31159624
14,80	16	203	152	128	48	M9408-1480AK	31159625
15,00	16	203	152	128	48	M9408-1500AK	31159626
15,20	16	203	152	128	48	M9408-1520AK	31159627
15,50	16	203	152	128	48	M9408-1550AK	31159628
15,80	16	203	152	128	48	M9408-1580AK	31159629
16,00	16	203	152	128	48	M9408-1600AK	31159630
16,50	18	222	171	144	48	M9408-1650AK	31159631
16,80	18	222	171	144	48	M9408-1680AK	31159632
17,00	18	222	171	144	48	M9408-1700AK	31159633
17,50	18	222	171	144	48	M9408-1750AK	31159634
17,80	18	222	171	144	48	M9408-1780AK	31159635
18,00	18	222	171	144	48	M9408-1800AK	31159636
18,50	20	243	190	160	50	M9408-1850AK	31159637
18,80	20	243	190	160	50	M9408-1880AK	31159638
19,00	20	243	190	160	50	M9408-1900AK	31159639
19,50	20	243	190	160	50	M9408-1950AK	31159640
19,80	20	243	190	160	50	M9408-1980AK	31159641
20,00	20	243	190	160	50	M9408-2000AK	31159642

**Konfigurierbare Merkmale**



**Durchmesser:**  
Durchmesser in Abstufungen  
von 0,01 mm frei wählbar



**Schaffform:**  
Schaffform: HB | HE

**Spezifikation:**

M9408-[Durchmesser][Schaffform]K

**Abmessungen konfigurierbare Baureihe**

d <sub>1</sub> min.	d <sub>1</sub> max.	d <sub>2</sub> h6	l <sub>1</sub>	l <sub>2</sub>	l <sub>3</sub>	l <sub>4</sub>
3,00	3,70	6	72	34	29	36
3,71	4,70	6	81	43	36	36
4,71	6,00	6	95	57	48	36
6,01	8,00	8	114	76	64	36
8,01	10,00	10	142	95	80	40
10,01	12,00	12	162	114	96	45
12,01	14,00	14	178	133	112	45
14,01	16,00	16	203	152	128	48
16,01	18,00	18	222	171	144	48
18,01	20,00	20	243	190	160	50

**Beispiel:**  
M9408-0431EK

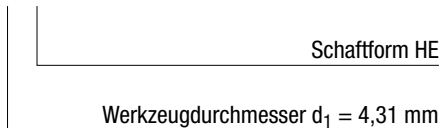

Maßangaben in mm.  
Schnittwertempfehlung siehe Kapitelende.  
Sonderausführungen und andere Beschichtungen auf Anfrage.

# MEGA-Speed-Drill-Inox

Vollhartmetall-Spiralbohrer  
M9412 (12xD), innere Kühlmittelzufuhr

**Ausführung:**

Bohrerdurchmesser: 3,00 - 20,00 mm  
Bohrungstoleranz:  $\geq$  IT 9  
Beschichtung: Mx2  
Schneidenanzahl: 2  
Anzahl Führungsfasen: 3  
Spitzenwinkel: 135°  
Spiralwinkel: 30°

**Anwendung:**

Für Hochgeschwindigkeitsbearbeitung.

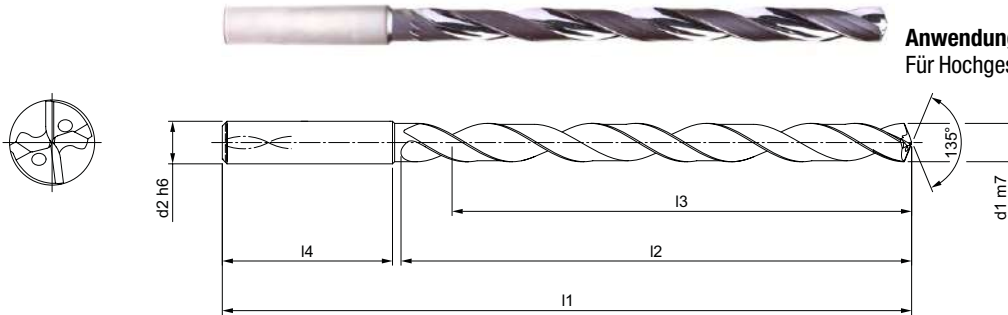

**Lagerhaltige Vorzugsbaureihe in Schaftform HA**

Baumaße						Schaftform HA	
d <sub>1</sub> m7	d <sub>2</sub> h6	l <sub>1</sub>	l <sub>2</sub>	l <sub>3</sub>	l <sub>4</sub>	Spezifikation	Bestell-Nr.
3,00	6	92	54	48	36	M9412-0300AK	31132176
3,10	6	92	54	48	36	M9412-0310AK	31132177
3,20	6	92	54	48	36	M9412-0320AK	31132178
3,30	6	92	54	48	36	M9412-0330AK	31132179
3,40	6	92	54	48	36	M9412-0340AK	31132210
3,50	6	92	54	48	36	M9412-0350AK	31132211
3,70	6	92	54	48	36	M9412-0370AK	31132213
4,00	6	102	64	58	36	M9412-0400AK	31132216
4,10	6	102	64	58	36	M9412-0410AK	31132217
4,20	6	102	64	58	36	M9412-0420AK	31132218
4,30	6	102	64	58	36	M9412-0430AK	31132219
4,50	6	102	64	58	36	M9412-0450AK	31132221
4,80	6	116	78	70	36	M9412-0480AK	31132224
5,00	6	116	78	70	36	M9412-0500AK	31132226
5,10	6	116	78	70	36	M9412-0510AK	31132227
5,20	6	116	78	70	36	M9412-0520AK	31132228
5,40	6	116	78	70	36	M9412-0540AK	31132230
5,50	6	116	78	70	36	M9412-0550AK	31132231
5,80	6	116	78	70	36	M9412-0580AK	31132234
6,00	6	116	78	70	36	M9412-0600AK	31132236
6,10	8	146	108	94	36	M9412-0610AK	31132237
6,20	8	146	108	94	36	M9412-0620AK	31132238
6,50	8	146	108	94	36	M9412-0650AK	31132241
6,80	8	146	108	94	36	M9412-0680AK	31132244
7,00	8	146	108	94	36	M9412-0700AK	31132246
7,50	8	146	108	94	36	M9412-0750AK	31132251
7,80	8	146	108	94	36	M9412-0780AK	31132254
8,00	8	146	108	94	36	M9412-0800AK	31132256
8,50	10	162	120	110	40	M9412-0850AK	31132261
9,00	10	162	120	110	40	M9412-0900AK	31132266
9,10	10	162	120	110	40	M9412-0910AK	31132267
9,50	10	162	120	110	40	M9412-0950AK	31132271
9,70	10	162	120	110	40	M9412-0970AK	31132273
9,80	10	162	120	110	40	M9412-0980AK	31132274
10,00	10	162	120	110	40	M9412-1000AK	31132276

**MEGA-Speed-Drill-Inox | Vollhartmetall-Spiralbohrer M9412 (12xD), innere Kühlmittelzufuhr**

Baumaße						Schaffform HA	
d <sub>1</sub> m7	d <sub>2</sub> h6	l <sub>1</sub>	l <sub>2</sub>	l <sub>3</sub>	l <sub>4</sub>	Spezifikation	Bestell-Nr.
10,10	12	204	156	142	45	M9412-1010AK	31132277
10,20	12	204	156	142	45	M9412-1020AK	31132278
10,50	12	204	156	142	45	M9412-1050AK	31132281
11,00	12	204	156	142	45	M9412-1100AK	31132286
11,80	12	204	156	142	45	M9412-1180AK	31132294
12,00	12	204	156	142	45	M9412-1200AK	31132296
12,50	14	230	182	166	45	M9412-1250AK	31132298
12,80	14	230	182	166	45	M9412-1280AK	31132299
13,00	14	230	182	166	45	M9412-1300AK	31132300
13,50	14	230	182	166	45	M9412-1350AK	31132301
14,00	14	230	182	166	45	M9412-1400AK	31132303
15,00	16	260	208	192	48	M9412-1500AK	31132306
16,00	16	260	208	192	48	M9412-1600AK	31132311

**Konfigurierbare Merkmale**



**Durchmesser:**  
Durchmesser in Abstufungen von 0,01 mm frei wählbar



**Schaffform:**  
Schaffform: HB | HE

**Spezifikation:**

M9412-[Durchmesser][Schaffform]K

**Abmessungen konfigurierbare Baureihe**

d <sub>1</sub> min.	d <sub>1</sub> max.	d <sub>2</sub> h6	l <sub>1</sub>	l <sub>2</sub>	l <sub>3</sub>	l <sub>4</sub>
3,00	3,70	6	92	54	48	36
3,71	4,70	6	102	64	58	36
4,71	6,00	6	116	78	70	36
6,01	8,00	8	146	108	94	36
8,01	10,00	10	162	120	110	40
10,01	12,00	12	204	156	142	45
12,01	14,00	14	230	182	166	45
14,01	16,00	16	260	208	192	48
16,01	18,00	18	285	234	216	48
18,01	20,00	20	310	258	240	50

**Beispiel:**  
M9412-0431EK

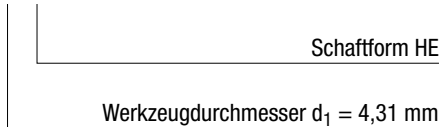

Maßangaben in mm.

Schnittwertempfehlung siehe Kapitelende.

Sonderausführungen und andere Beschichtungen auf Anfrage.

# MEGA-Speed-Drill-Iron

Vollhartmetall-Spiralbohrer  
M9505 (5xD), innere Kühlmittelzufuhr

**Ausführung:**  
Bohrerdurchmesser: 3,00 - 20,00 mm  
Bohrungstoleranz:  $\geq$  IT 9  
Beschichtung: MxM  
Schneidenanzahl: 2  
Anzahl Führungsfasen: 3  
Spitzenwinkel: 130°  
Spiralwinkel: 30°

**Anwendung:**  
Für Hochgeschwindigkeitsbearbeitung.

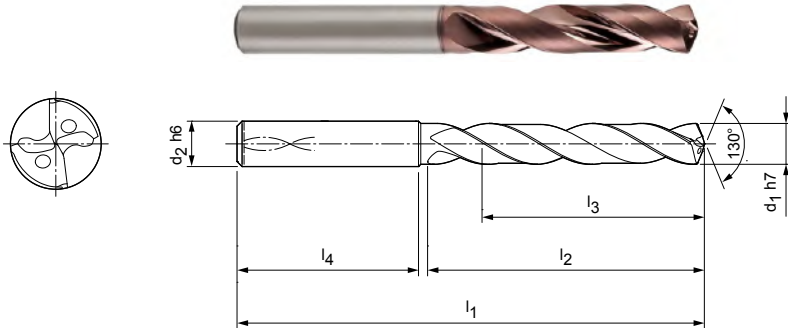

## Lagerhaltige Vorzugsbaureihe in Schaftform HA

Baumaße						Schaftform HA	
d <sub>1</sub> h7	d <sub>2</sub> h6	l <sub>1</sub>	l <sub>2</sub>	l <sub>3</sub>	l <sub>4</sub>	Spezifikation	Bestell-Nr.
5,00	6	82	44	35	36	M9505-0500AP	30484217
5,10	6	82	44	35	36	M9505-0510AP	30484218
6,00	6	82	44	35	36	M9505-0600AP	30484228
6,90	8	91	53	43	36	M9505-0690AP	30484237
7,00	8	91	53	43	36	M9505-0700AP	30484238
7,20	8	91	53	43	36	M9505-0720AP	30484240
8,10	10	103	61	49	40	M9505-0810AP	30484249
8,50	10	103	61	49	40	M9505-0850AP	30484253
9,00	10	103	61	49	40	M9505-0900AP	30484258
14,00	14	124	77	60	45	M9505-1400AP	30484294
17,50	18	143	93	71	48	M9505-1750AP	30484304

## Konfigurierbare Merkmale

**Durchmesser:**  
Durchmesser in Abstufungen von 0,01 mm frei wählbar

**Schaftform:**  
Schaftform: HB | HE

**Spezifikation:**  
M9505-[Durchmesser][Schaftform]P

## Abmessungen konfigurierbare Baureihe

d <sub>1</sub> min.	d <sub>1</sub> max.	d <sub>2</sub> h6	l <sub>1</sub>	l <sub>2</sub>	l <sub>3</sub>	l <sub>4</sub>
3,00	3,70	6	66	28	23	36
3,71	4,79	6	74	36	29	36
4,80	6,00	6	82	44	35	36
6,01	8,00	8	91	53	43	36
8,01	10,00	10	103	61	49	40
10,01	12,00	12	118	71	56	45
12,01	14,00	14	124	77	60	45
14,01	16,00	16	133	83	63	48
16,01	18,00	18	143	93	71	48
18,01	20,00	20	153	101	77	50

**Beispiel:**  
M9505-0431EP

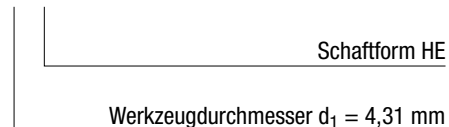

Maßangaben in mm.  
Schnittwertempfehlung siehe Kapitelende.  
Sonderausführungen und andere Beschichtungen auf Anfrage.

# MEGA-Speed-Drill-Titan

Vollhartmetall-Spiralbohrer  
M9605 (5xD), innere Kühlmittelzufuhr

**Ausführung:**  
Bohrerdurchmesser: 3,00 - 20,00 mm  
Bohrungstoleranz: IT 9  
Beschichtung: Mx17  
Schneidenanzahl: 2  
Anzahl Führungsfasen: 4  
Spitzenwinkel: 140°  
Spiralwinkel: 30°

**Anwendung:**  
Für Hochgeschwindigkeitsbearbeitung.

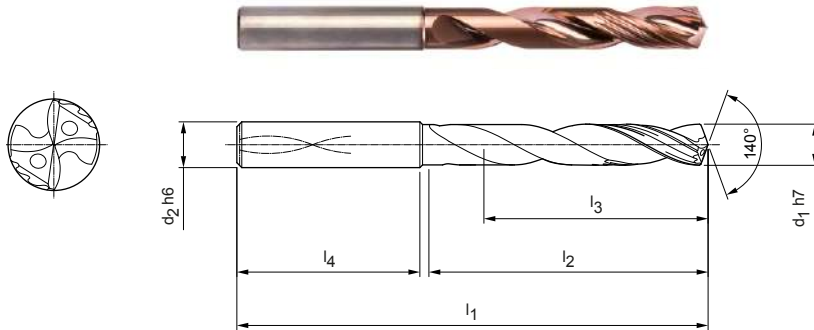

## Lagerhaltige Vorzugsbaureihe

Baumaße						Schaftform HA	
d <sub>1</sub> h7	d <sub>2</sub> h6	l <sub>1</sub>	l <sub>2</sub>	l <sub>3</sub>	l <sub>4</sub>	Spezifikation	Bestell-Nr.
3,00	6	66	28	23	36	M9605-0300A12	31315877
3,10	6	66	28	23	36	M9605-0310A12	31315878
3,20	6	66	28	23	36	M9605-0320A12	31315879
3,30	6	66	28	23	36	M9605-0330A12	31315880
3,40	6	66	28	23	36	M9605-0340A12	31315881
3,50	6	66	28	23	36	M9605-0350A12	31315882
3,60	6	66	28	23	36	M9605-0360A12	31315883
3,70	6	66	28	23	36	M9605-0370A12	31315884
3,80	6	74	36	29	36	M9605-0380A12	31315885
4,00	6	74	36	29	36	M9605-0400A12	31315886
4,10	6	74	36	29	36	M9605-0410A12	31315887
4,20	6	74	36	29	36	M9605-0420A12	31315888
4,30	6	74	36	29	36	M9605-0430A12	31315889
4,40	6	74	36	29	36	M9605-0440A12	31315890
4,50	6	74	36	29	36	M9605-0450A12	31315891
4,60	6	74	36	29	36	M9605-0460A12	31315892
4,70	6	74	36	29	36	M9605-0470A12	31315893
4,80	6	82	44	35	36	M9605-0480A12	31315894
5,00	6	82	44	35	36	M9605-0500A12	31315895
5,10	6	82	44	35	36	M9605-0510A12	31315896
5,20	6	82	44	35	36	M9605-0520A12	31315897
5,30	6	82	44	35	36	M9605-0530A12	31315898
5,40	6	82	44	35	36	M9605-0540A12	31315899
5,50	6	82	44	35	36	M9605-0550A12	31315900
5,80	6	82	44	35	36	M9605-0580A12	31315901
5,90	6	82	44	35	36	M9605-0590A12	31315902
6,00	6	82	44	35	36	M9605-0600A12	31315903
6,20	8	91	53	43	36	M9605-0620A12	31315904
6,50	8	91	53	43	36	M9605-0650A12	31315905
6,60	8	91	53	43	36	M9605-0660A12	31315906
6,80	8	91	53	43	36	M9605-0680A12	31315907
7,00	8	91	53	43	36	M9605-0700A12	31315908
7,10	8	91	53	43	36	M9605-0710A12	31315909
7,30	8	91	53	43	36	M9605-0730A12	31315910
7,40	8	91	53	43	36	M9605-0740A12	31315911

## MEGA-Speed-Drill-Titan | Vollhartmetall-Spiralbohrer M9605 (5xD), innere Kühlmittelzufuhr

Baumaße						Schaftform HA	
d <sub>1</sub> h7	d <sub>2</sub> h6	l <sub>1</sub>	l <sub>2</sub>	l <sub>3</sub>	l <sub>4</sub>	Spezifikation	Bestell-Nr.
7,50	8	91	53	43	36	M9605-0750A12	31315912
7,80	8	91	53	43	36	M9605-0780A12	31315913
8,00	8	91	53	43	36	M9605-0800A12	31315914
8,10	10	103	61	49	40	M9605-0810A12	31315915
8,20	10	103	61	49	40	M9605-0820A12	31315916
8,30	10	103	61	49	40	M9605-0830A12	31315917
8,40	10	103	61	49	40	M9605-0840A12	31315918
8,50	10	103	61	49	40	M9605-0850A12	31315919
8,80	10	103	61	49	40	M9605-0880A12	31315920
9,00	10	103	61	49	40	M9605-0900A12	31315921
9,80	10	103	61	49	40	M9605-0980A12	31315922
10,00	10	103	61	49	40	M9605-1000A12	31315923
10,20	12	118	71	56	45	M9605-1020A12	31315924
10,50	12	118	71	56	45	M9605-1050A12	31315925
11,00	12	118	71	56	45	M9605-1100A12	31315926
11,80	12	118	71	56	45	M9605-1180A12	31315927
12,00	12	118	71	56	45	M9605-1200A12	31315928
12,50	14	124	77	60	45	M9605-1250A12	31315929
13,00	14	124	77	60	45	M9605-1300A12	31315930
13,50	14	124	77	60	45	M9605-1350A12	31315931
14,00	14	124	77	60	45	M9605-1400A12	31315932
15,80	16	133	83	63	48	M9605-1580A12	31315933
16,00	16	133	83	63	48	M9605-1600A12	31315934

## Konfigurierbare Merkmale

**Durchmesser:**

Durchmesser in Abstufungen  
von 0,01 mm frei wählbar

**Schaftform:**

Schaftform: HB | HE

**Spezifikation:**

M9605-[Durchmesser][Schaftform]12

Beispiel:  
M9605-0470E12

Schaftform HE

Werkzeugdurchmesser d<sub>1</sub> = 4,70 mm

## Abmessungen konfigurierbare Baureihe

d <sub>1</sub> min.	d <sub>1</sub> max.	d <sub>2</sub> h6	l <sub>1</sub>	l <sub>2</sub>	l <sub>3</sub>	l <sub>4</sub>
3,00	3,70	6	66	28	23	36
3,71	4,70	6	74	36	29	36
4,71	6,00	6	82	44	35	36
6,01	6,80	8	91	53	43	36
6,81	8,00	8	91	53	43	36
8,01	9,00	10	103	61	49	40
9,01	10,00	10	103	61	49	40
10,01	11,00	12	118	71	56	45
11,01	12,00	12	118	71	56	45
12,01	14,00	14	124	77	60	45
14,01	16,00	16	133	83	63	48
16,01	18,00	18	143	93	71	48
18,01	20,00	20	153	101	77	50

Maßangaben in mm.

Schnittwertempfehlung siehe Kapitelende.

Sonderausführungen und andere Beschichtungen auf Anfrage.

# Tritan-Drill-Alu

Vollhartmetall-Spiralbohrer  
M9835 (5xD), innere Kühlmittelzufuhr

**Ausführung:**  
Bohrerdurchmesser: 4,00 - 20,00 mm  
Bohrungstoleranz:  $\geq$  IT 9  
Beschichtung: Unbeschichtet  
Schneidenanzahl: 3  
Anzahl Führungsfasen: 3  
Spitzenwinkel: 130°  
Spiralwinkel: 30°

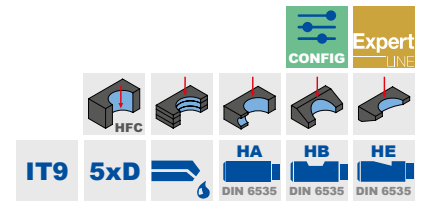
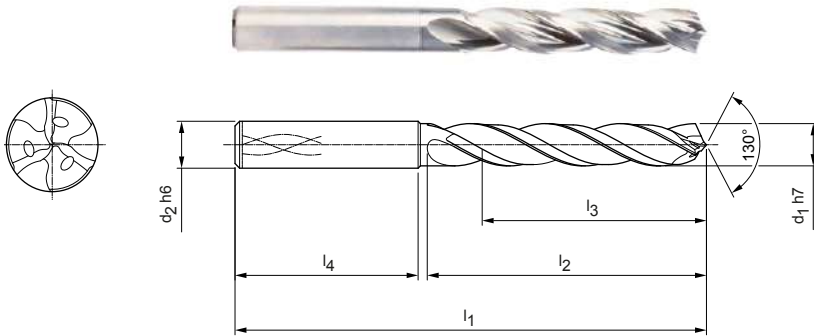

## Lagerhaltige Vorzugsbaureihe

Baumaße						Schaftform HA	
d <sub>1</sub> h7	d <sub>2</sub> h6	l <sub>1</sub>	l <sub>2</sub>	l <sub>3</sub>	l <sub>4</sub>	Spezifikation	Bestell-Nr.
4,00	6	74	36	29	36	M9835-0400AU	31307556
4,10	6	74	36	29	36	M9835-0410AU	31307557
4,20	6	74	36	29	36	M9835-0420AU	31307558
4,30	6	74	36	29	36	M9835-0430AU	31307559
4,50	6	74	36	29	36	M9835-0450AU	31307560
4,60	6	74	36	29	36	M9835-0460AU	31307561
4,65	6	74	36	29	36	M9835-0465AU	31307562
4,80	6	82	44	35	36	M9835-0480AU	31307563
4,90	6	82	44	35	36	M9835-0490AU	31307564
5,00	6	82	44	35	36	M9835-0500AU	31307565
5,10	6	82	44	35	36	M9835-0510AU	31307566
5,20	6	82	44	35	36	M9835-0520AU	31307567
5,30	6	82	44	35	36	M9835-0530AU	31307568
5,50	6	82	44	35	36	M9835-0550AU	31307569
5,55	6	82	44	35	36	M9835-0555AU	31307570
5,60	6	82	44	35	36	M9835-0560AU	31307571
5,80	6	82	44	35	36	M9835-0580AU	31307572
5,90	6	82	44	35	36	M9835-0590AU	31307573
6,00	6	82	44	35	36	M9835-0600AU	31307574
6,10	8	91	53	43	36	M9835-0610AU	31307575
6,20	8	91	53	43	36	M9835-0620AU	31307576
6,30	8	91	53	43	36	M9835-0630AU	31307577
6,40	8	91	53	43	36	M9835-0640AU	31307578
6,50	8	91	53	43	36	M9835-0650AU	31307579
6,60	8	91	53	43	36	M9835-0660AU	31307580
6,80	8	91	53	43	36	M9835-0680AU	31307581
6,90	8	91	53	43	36	M9835-0690AU	31307582
7,00	8	91	53	43	36	M9835-0700AU	31307583
7,40	8	91	53	43	36	M9835-0740AU	31307585
7,45	8	91	53	43	36	M9835-0745AU	31307586
7,50	8	91	53	43	36	M9835-0750AU	31307587
7,80	8	91	53	43	36	M9835-0780AU	31307588
8,00	8	91	53	43	36	M9835-0800AU	31307589
8,10	10	103	61	49	40	M9835-0810AU	31307590
8,40	10	103	61	49	40	M9835-0840AU	31307591

## Tritan-Drill-Alu | Vollhartmetall-Spiralbohrer M9835 (5xD), innere Kühlmittelzufuhr

Baumaße						Schaftform HA	
d <sub>1</sub> h7	d <sub>2</sub> h6	l <sub>1</sub>	l <sub>2</sub>	l <sub>3</sub>	l <sub>4</sub>	Spezifikation	Bestell-Nr.
8,50	10	103	61	49	40	M9835-0850AU	31307592
8,80	10	103	61	49	40	M9835-0880AU	31307593
9,00	10	103	61	49	40	M9835-0900AU	31307594
9,10	10	103	61	49	40	M9835-0910AU	31307595
9,80	10	103	61	49	40	M9835-0980AU	31307596
10,00	10	103	61	49	40	M9835-1000AU	31307597
10,20	12	118	71	56	45	M9835-1020AU	31307598
10,50	12	118	71	56	45	M9835-1050AU	31307599
11,00	12	118	71	56	45	M9835-1100AU	31307600
11,50	12	118	71	56	45	M9835-1150AU	31307601
11,80	12	118	71	56	45	M9835-1180AU	31307602
12,00	12	118	71	56	45	M9835-1200AU	31307603
12,50	14	124	77	60	45	M9835-1250AU	31307604
13,00	14	124	77	60	45	M9835-1300AU	31307605
14,00	14	124	77	60	45	M9835-1400AU	31307606
15,00	16	133	83	63	48	M9835-1500AU	31307607
16,00	16	133	83	63	48	M9835-1600AU	31307608

## Konfigurierbare Merkmale

**Durchmesser:**

Durchmesser in Abstufungen von 0,01 mm frei wählbar

**Schaftform:**

Schaftform: HB | HE

**Beschichtung:**

Als DLC-Beschichtung mit Beschichtung MF8 erhältlich

**Spezifikation:**

M9835-[Durchmesser][Schaftform][Beschichtung]

## Abmessungen konfigurierbare Baureihe

d <sub>1</sub> min.	d <sub>1</sub> max.	d <sub>2</sub> h6	l <sub>1</sub>	l <sub>2</sub>	l <sub>3</sub>	l <sub>4</sub>
4,00	4,70	6	74	36	29	36
4,71	6,00	6	82	44	35	36
6,01	7,00	8	91	53	43	36
7,01	8,00	8	91	53	43	36
8,01	9,00	10	103	61	49	40
9,01	10,00	10	103	61	49	40
10,01	11,00	12	118	71	56	45
11,01	12,00	12	118	71	56	45
12,01	14,00	14	124	77	60	45
14,01	16,00	16	133	83	63	48
16,01	18,00	18	143	93	71	48
18,01	20,00	20	153	101	77	50

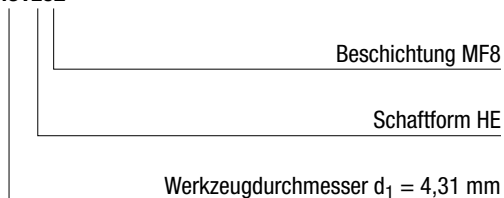
**Beispiel:**  
M9835-0431E02

Maßangaben in mm.

Schnittwertempfehlung siehe nächste Seite.

Sonderausführungen und andere Beschichtungen auf Anfrage.



# MEGA-Drill-Alu

Vollhartmetall-Spiralbohrer  
M2803 (3xD), innere Kühlmittelzufuhr

**Ausführung:**

Bohrerdurchmesser: 3,00 - 20,00 mm  
Bohrungstoleranz:  $\geq$  IT 9  
Beschichtung: Unbeschichtet  
Schneidenanzahl: 2  
Anzahl Führungsfasen: 2  
Spitzenwinkel: 140°  
Spiralwinkel: 30°

**Anwendung:**

Als Pilotbohrer für MEGA-Deep-Drill-Alu geeignet.

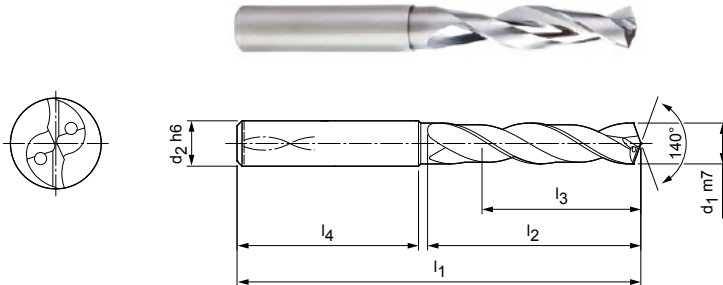

**Lagerhaltige Vorzugsbaureihe in Schaftform HA**

Baumaße						Schaftform HA	
d <sub>1</sub> m7	d <sub>2</sub> h6	l <sub>1</sub>	l <sub>2</sub>	l <sub>3</sub>	l <sub>4</sub>	Spezifikation	Bestell-Nr.
6,50	8	79	34	24	36	M2803-0650AU	30143130
6,70	8	79	34	24	36	M2803-0670AU	30143134
7,00	8	79	34	24	36	M2803-0700AU	30143139
10,00	10	89	47	35	40	M2803-1000AU	30120790
11,00	12	102	55	40	45	M2803-1100AU	30143216
12,00	12	102	55	40	45	M2803-1200AU	30143237
13,20	14	107	60	43	45	M2803-1320AU	30695014
13,70	14	107	60	43	45	M2803-1370AU	30694871
16,00	16	115	65	45	48	M2803-1600AU	30143254

**Konfigurierbare Merkmale**

**Durchmesser:**  
Durchmesser in Abstufungen von 0,01 mm frei wählbar

**Schaftform:**  
Schaftform: HB | HE

**Spezifikation:**  
M2803-[Durchmesser][Schaftform]U

**Abmessungen konfigurierbare Baureihe**

d <sub>1</sub> min.	d <sub>1</sub> max.	d <sub>2</sub> h6	l <sub>1</sub>	l <sub>2</sub>	l <sub>3</sub>	l <sub>4</sub>
3,00	3,50	6	62	20	14	36
3,51	4,50	6	66	24	17	36
4,51	6,00	6	66	28	20	36
6,01	7,97	8	79	34	24	36
7,98	8,00	8	79	41	29	36
8,01	10,00	10	89	47	35	40
10,01	12,00	12	102	55	40	45
12,01	14,00	14	107	60	43	45
14,01	16,00	16	115	65	45	48
16,01	18,00	18	123	73	51	48
18,01	20,00	20	131	79	55	50

Beispiel:  
M2803-0431EU

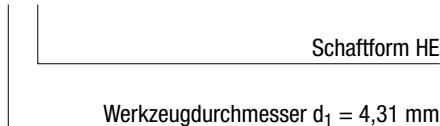

Maßangaben in mm.  
Schnittwertempfehlung siehe Kapitelende.  
Sonderausführungen und andere Beschichtungen auf Anfrage.

# MEGA-Drill-Alu

Vollhartmetall-Spiralbohrer  
M2805 (5xD), innere Kühlmittelzufuhr

**Ausführung:**

Bohrerdurchmesser: 2,80 - 20,00 mm  
Bohrungstoleranz:  $\geq$  IT 9  
Beschichtung: Unbeschichtet  
Schneidenanzahl: 2  
Anzahl Führungsfasen: 2  
Spitzenwinkel: 140°  
Spiralwinkel: 30°

**Anwendung:**

Als Pilotbohrer für MEGA-Deep-Drill-Alu geeignet.

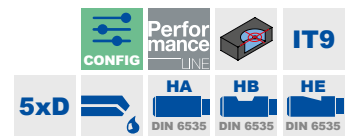
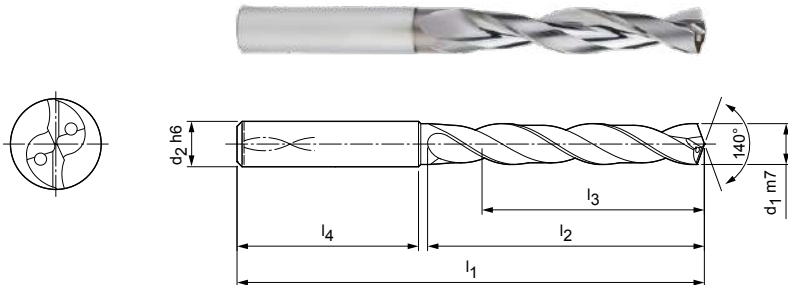

**Lagerhaltige Vorzugsbaureihe in Schaftform HA**

Baumaße						Schaftform HA	
d <sub>1</sub> m7	d <sub>2</sub> h6	l <sub>1</sub>	l <sub>2</sub>	l <sub>3</sub>	l <sub>4</sub>	Spezifikation	Bestell-Nr.
3,00	6	66	28	23	36	M2805-0300AU	30143279
3,20	6	66	28	23	36	M2805-0320AU	30143283
3,30	6	66	28	23	36	M2805-0330AU	30095975
3,50	6	66	28	23	36	M2805-0350AU	30143286
3,70*	6	66	28	23	36	M2805-0370AU	30143289
3,90	6	74	36	29	36	M2805-0390AU	30143292
4,00	6	74	36	29	36	M2805-0400AU	30143294
4,10	6	74	36	29	36	M2805-0410AU	30143296
4,20	6	74	36	29	36	M2805-0420AU	30143298
4,30	6	74	36	29	36	M2805-0430AU	30143300
4,50	6	74	36	29	36	M2805-0450AU	30061240
4,60	6	74	36	29	36	M2805-0460AU	30143304
4,70	6	74	36	29	36	M2805-0470AU	30143305
5,00	6	82	44	35	36	M2805-0500AU	30075688
5,10	6	82	44	35	36	M2805-0510AU	30061247
5,20	6	82	44	35	36	M2805-0520AU	30143308
5,50	6	82	44	35	36	M2805-0550AU	30143316
5,60	6	82	44	35	36	M2805-0560AU	30143317
6,00	6	82	44	35	36	M2805-0600AU	30143324
6,10	8	91	53	43	36	M2805-0610AU	30143325
6,20	8	91	53	43	36	M2805-0620AU	30143326
6,30	8	91	53	43	36	M2805-0630AU	30061260
6,40	8	91	53	43	36	M2805-0640AU	30143329
6,50	8	91	53	43	36	M2805-0650AU	30143330
6,60	8	91	53	43	36	M2805-0660AU	30143331
6,80	8	91	53	43	36	M2805-0680AU	30143333
7,00	8	91	53	43	36	M2805-0700AU	30073382
7,40	8	91	53	43	36	M2805-0740AU	30143343
7,50	8	91	53	43	36	M2805-0750AU	30143345
7,60	8	91	53	43	36	M2805-0760AU	30143347
8,00	8	91	53	43	36	M2805-0800AU	30143355
8,40	10	103	61	49	40	M2805-0840AU	30143363
8,50	10	103	61	49	40	M2805-0850AU	30143364
8,73	10	103	61	49	40	M2805-0873AU	30181494
8,90	10	103	61	49	40	M2805-0890AU	30143372

## MEGA-Drill-Alu | Vollhartmetall-Spiralbohrer M2805 (5xD), innere Kühlmittelzufuhr

Baumaße						Schaffform HA	
d <sub>1</sub> m7	d <sub>2</sub> h6	l <sub>1</sub>	l <sub>2</sub>	l <sub>3</sub>	l <sub>4</sub>	Spezifikation	Bestell-Nr.
9,00	10	103	61	49	40	M2805-0900AU	30061280
9,20	10	103	61	49	40	M2805-0920AU	30143376
9,30*	10	103	61	49	40	M2805-0930AU	30061284
9,50	10	103	61	49	40	M2805-0950AU	30097044
9,60	10	103	61	49	40	M2805-0960AU	30143381
10,00	10	103	61	49	40	M2805-1000AU	30143388
10,20	12	118	71	56	45	M2805-1020AU	30143391
10,50	12	118	71	56	45	M2805-1050AU	30143396
10,80	12	118	71	56	45	M2805-1080AU	30143403
11,00	12	118	71	56	45	M2805-1100AU	30061301
11,50	12	118	71	56	45	M2805-1150AU	30143413
12,00	12	118	71	56	45	M2805-1200AU	30143424
12,50	14	124	77	60	45	M2805-1250AU	30143425
13,50	14	124	77	60	45	M2805-1350AU	30061313
14,00	14	124	77	60	45	M2805-1400AU	30143431
16,00	16	133	83	63	48	M2805-1600AU	30143440
20,00	20	153	101	77	50	M2805-2000AU	30143465

## Konfigurierbare Merkmale

**Durchmesser:**

Durchmesser in Abstufungen  
von 0,01 mm frei wählbar

**Schaffform:**

Schaffform: HB | HE

**Spezifikation:**

M2805-[Durchmesser][Schaffform]U

## Abmessungen konfigurierbare Baureihe

d <sub>1</sub> min.	d <sub>1</sub> max.	d <sub>2</sub> h6	l <sub>1</sub>	l <sub>2</sub>	l <sub>3</sub>	l <sub>4</sub>
2,80	3,70	6	66	28	23	36
3,71	4,70	6	74	36	29	36
4,71	6,00	6	82	44	35	36
6,01	8,00	8	91	53	43	36
8,01	10,00	10	103	61	49	40
10,01	12,00	12	118	71	56	45
12,01	14,00	14	124	77	60	45
14,01	16,00	16	133	83	63	48
16,01	18,00	18	143	93	71	48
18,01	20,00	20	153	101	77	50

Beispiel:  
M2805-0431EU

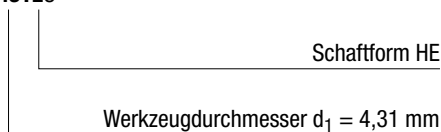

Maßangaben in mm.

\* Speziell zur Vorfertigung der Kernlöcher für Gewindeformer geeignet.

Schnittwertempfehlung siehe Kapitelende.

Sonderausführungen und andere Beschichtungen auf Anfrage.

# MEGA-Drill-Alu

Vollhartmetall-Spiralbohrer  
M2808 (8xD), innere Kühlmittelzufuhr

**Ausführung:**

Bohrerdurchmesser: 3,00 - 20,00 mm  
Bohrungstoleranz:  $\geq$  IT 9  
Beschichtung: Unbeschichtet  
Schneidenanzahl: 2  
Anzahl Führungsfasen: 2  
Spitzenwinkel: 140°  
Spiralwinkel: 30°

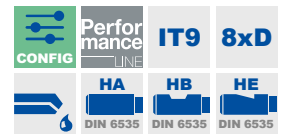
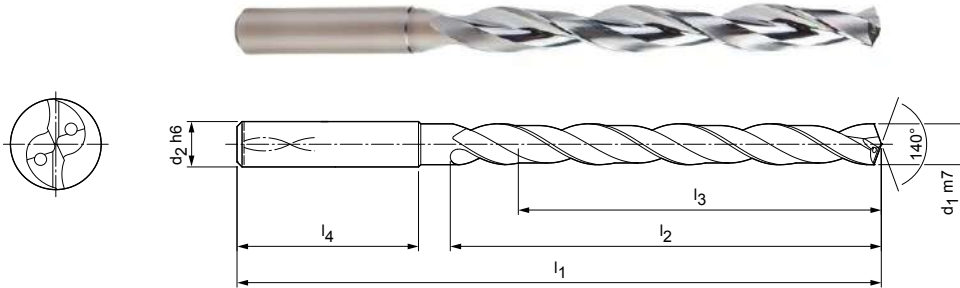

**Lagerhaltige Vorzugsbaureihe in Schaftform HA**

Baumaße						Schaftform HA	
d <sub>1</sub> m7	d <sub>2</sub> h6	l <sub>1</sub>	l <sub>2</sub>	l <sub>3</sub>	l <sub>4</sub>	Spezifikation	Bestell-Nr.
3,00	6	72	34	29	36	M2808-0300AU	30076900
3,30	6	72	34	29	36	M2808-0330AU	30143469
3,50	6	72	34	29	36	M2808-0350AU	30143472
3,70	6	72	34	29	36	M2808-0370AU	30143474
4,00	6	81	43	36	36	M2808-0400AU	30143480
4,50	6	81	43	36	36	M2808-0450AU	30061342
5,00	6	95	57	48	36	M2808-0500AU	30096652
5,50	6	95	57	48	36	M2808-0550AU	30063592
6,50	8	114	76	64	36	M2808-0650AU	30143516
6,80	8	114	76	64	36	M2808-0680AU	30143520
7,00	8	114	76	64	36	M2808-0700AU	30143522
8,00	8	114	76	64	36	M2808-0800AU	30143537
9,30	10	142	95	80	40	M2808-0930AU	30061380
11,00	12	162	114	96	45	M2808-1100AU	30061400
12,00	12	162	114	96	45	M2808-1200AU	30061401

**Konfigurierbare Merkmale**



**Durchmesser:**  
Durchmesser in Abstufungen  
von 0,01 mm frei wählbar



**Schaftform:**  
Schaftform: HB | HE

**Spezifikation:**

M2808-[Durchmesser][Schaftform]U

**Abmessungen konfigurierbare Baureihe**

d <sub>1</sub> min.	d <sub>1</sub> max.	d <sub>2</sub> h6	l <sub>1</sub>	l <sub>2</sub>	l <sub>3</sub>	l <sub>4</sub>
3,00	3,70	6	72	34	29	36
3,71	4,70	6	81	43	36	36
4,71	6,00	6	95	57	48	36
6,01	8,00	8	114	76	64	36
8,01	10,00	10	142	95	80	40
10,01	12,00	12	162	114	96	45
12,01	14,00	14	178	133	112	45
14,01	16,00	16	203	152	128	48
16,01	18,00	18	222	171	144	48
18,01	20,00	20	243	190	160	50

**Beispiel:**  
M2808-0431EU

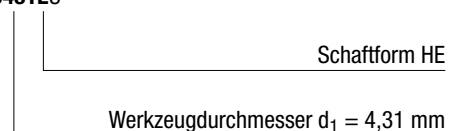

Maßangaben in mm.  
Schnittwertempfehlung siehe Kapitelende.  
Sonderausführungen und andere Beschichtungen auf Anfrage.

# MEGA-Drill-Alu

Vollhartmetall-Spiralbohrer  
M2812 (12xD), innere Kühlmittelzufuhr

**Ausführung:**

Bohrerdurchmesser: 3,00 - 20,00 mm  
Bohrungstoleranz:  $\geq IT 9$   
Beschichtung: Unbeschichtet  
Schneidenanzahl: 2  
Anzahl Führungsfasen: 2  
Spitzenwinkel:  $140^\circ$   
Spiralwinkel:  $30^\circ$

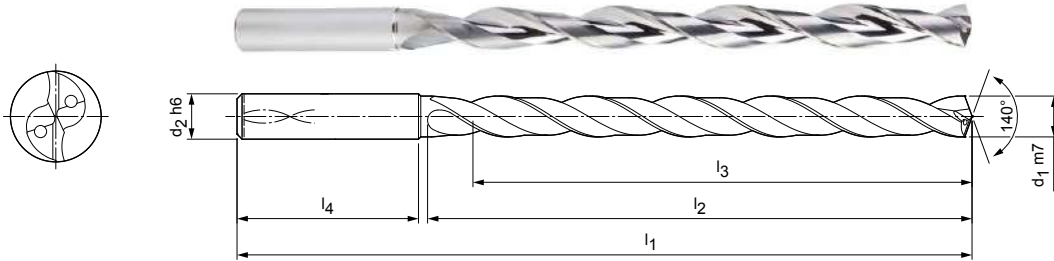

**Lagerhaltige Vorzugsbaureihe in Schaftform HA**

Baumaße						Schaftform HA	
d <sub>1</sub> m7	d <sub>2</sub> h6	l <sub>1</sub>	l <sub>2</sub>	l <sub>3</sub>	l <sub>4</sub>	Spezifikation	Bestell-Nr.
3,00	6	92	54	48	36	M2812-0300AU	30076901
3,50	6	92	54	48	36	M2812-0350AU	30143670
4,00	6	102	64	58	36	M2812-0400AU	30061413
4,70	6	102	64	58	36	M2812-0470AU	30063638
5,00	6	116	78	70	36	M2812-0500AU	30061422
5,40	6	116	78	70	36	M2812-0540AU	30063644
5,50	6	116	78	70	36	M2812-0550AU	30143698
5,60	6	116	78	70	36	M2812-0560AU	30063645
6,00	6	116	78	70	36	M2812-0600AU	30063648
6,50	8	146	108	94	36	M2812-0650AU	30143713
6,60	8	146	108	94	36	M2812-0660AU	30143715
7,00	8	146	108	94	36	M2812-0700AU	30143720
8,00	8	146	108	94	36	M2812-0800AU	30143736
9,00	10	162	120	110	40	M2812-0900AU	30074972

**Konfigurierbare Merkmale**



**Durchmesser:**  
Durchmesser in Abstufungen von 0,01 mm frei wählbar



**Schaftform:**  
Schaftform: HB | HE

**Spezifikation:**

M2812-[Durchmesser][Schaftform]U

**Abmessungen konfigurierbare Baureihe**

d <sub>1</sub> min.	d <sub>1</sub> max.	d <sub>2</sub> h6	l <sub>1</sub>	l <sub>2</sub>	l <sub>3</sub>	l <sub>4</sub>
3,00	3,70	6	92	54	48	36
3,71	4,70	6	102	64	58	36
4,71	6,00	6	116	78	70	36
6,01	8,00	8	146	108	94	36
8,01	10,00	10	162	120	110	40
10,01	12,00	12	204	156	142	45
12,01	14,00	14	230	182	166	45
14,01	16,00	16	260	208	192	48
16,01	18,00	18	285	234	216	48
18,01	20,00	20	310	258	240	50

**Beispiel:**  
M2812-0431EU

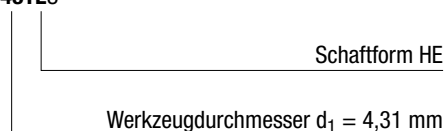

Maßangaben in mm.  
Schnittwertempfehlung siehe Kapitelende.  
Sonderausführungen und andere Beschichtungen auf Anfrage.

# MEGA-Drill-Composite-MD

Vollhartmetall-Spiralbohrer

M1985, M2925 (5xD), äußere Kühlmittelzufuhr

**Ausführung:**

Bohrerdurchmesser: 0,50 - 12,00 mm  
 Beschichtung: Diamant-Beschichtet  
 Schneidanzahl: 2  
 Anzahl Führungsfasen: 2  
 Spitzenwinkel: 90°  
 Spiralwinkel: 35°

**Anwendung:**

CFK mit multidirektionalem Faserverlauf.

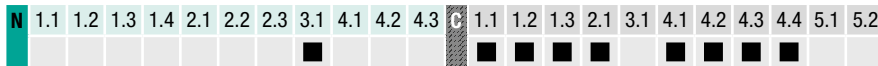
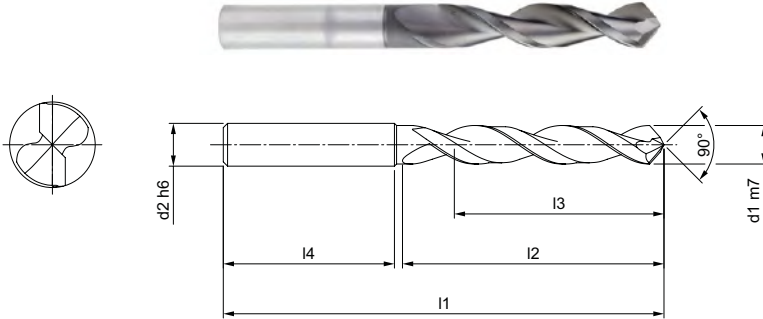

Baumaße						Schaffform HA	
d <sub>1</sub> m7	d <sub>2</sub> h6	l <sub>1</sub>	l <sub>2</sub>	l <sub>3</sub>	l <sub>4</sub>	Spezifikation	Bestell-Nr.
0,50	3	55	4,5	3	46	M1985-0050AQ	30467692
2,00	3	68	14	11	51	M1985-0200AQ	30467707
2,50	3	74	18	14	54	M1985-0250AQ	30467712
3,00	6	66	28	23	36	M2925-0300AQ	30290565
3,10	6	66	28	23	36	M2925-0310AQ	30290566
3,20	6	66	28	23	36	M2925-0320AQ	30290568
3,30	6	66	28	23	36	M2925-0330AQ	30290569
3,80	6	66	28	23	36	M2925-0380AQ	30290574
4,00	6	74	36	29	36	M2925-0400AQ	30290576
4,10	6	74	36	29	36	M2925-0410AQ	30290577
4,20	6	74	36	29	36	M2925-0420AQ	30290578
4,30	6	74	36	29	36	M2925-0430AQ	30290579
4,50	6	74	36	29	36	M2925-0450AQ	30290581
4,80	6	74	36	29	36	M2925-0480AQ	30290585
4,86	6	74	36	0	36	M2925-0486AQ	30534324
5,00	6	82	44	35	36	M2925-0500AQ	30290587
5,10	6	82	44	35	36	M2925-0510AQ	30290588
5,20	6	82	44	35	36	M2925-0520AQ	30290589
5,30	6	82	44	35	36	M2925-0530AQ	30290590
5,50	6	82	44	35	36	M2925-0550AQ	30290592
5,60	6	82	44	35	36	M2925-0560AQ	30290593
5,80	6	82	44	35	36	M2925-0580AQ	30290595
6,00	6	82	44	35	36	M2925-0600AQ	30290597
6,50	8	91	53	43	36	M2925-0650AQ	30290603
6,80	8	91	53	43	36	M2925-0680AQ	30290606
7,00	8	91	53	43	36	M2925-0700AQ	30290608
7,20	8	91	53	43	36	M2925-0720AQ	30290610
7,50	8	91	53	43	36	M2925-0750AQ	30290613
7,80	8	91	53	43	36	M2925-0780AQ	30290616
8,00	8	91	53	43	36	M2925-0800AQ	30290619
8,50	10	103	61	49	40	M2925-0850AQ	30290624
8,80	10	103	61	49	40	M2925-0880AQ	30290627
10,00	10	103	61	49	40	M2925-1000AQ	30290640

**MEGA-Drill-Composite-MD | Vollhartmetall-Spiralbohrer M1985, M2925 (5xD), äußere Kühlmittelzufuhr**

Baumaße						Schaffform HA	
d <sub>1</sub> m7	d <sub>2</sub> h6	l <sub>1</sub>	l <sub>2</sub>	l <sub>3</sub>	l <sub>4</sub>	Spezifikation	Bestell-Nr.
10,10	12	118	71	56	45	M2925-1010AQ	30290641
10,40	12	118	71	56	45	M2925-1040AQ	30290644
10,70	12	118	71	56	45	M2925-1070AQ	30290647
12,00	12	118	71	56	45	M2925-1200AQ	30290661

**Konfigurierbare Merkmale**

**Durchmesser:**  
Durchmesser in Abstufungen  
von 0,01 mm frei wählbar



**Schaffform:**  
Schaffform: HB | HE

**Spezifikation:**

M2925-[Durchmesser][Schaffform]Q

**Abmessungen konfigurierbare Baureihe**

d <sub>1</sub> min.	d <sub>1</sub> max.	d <sub>2</sub> h6	l <sub>1</sub>	l <sub>2</sub>	l <sub>3</sub>	l <sub>4</sub>
3,00	3,99	6	66	28	23	36
4,00	4,99	6	74	36	29	36
5,00	6,00	6	82	44	35	36
6,01	8,00	8	91	53	43	36
8,01	10,00	10	103	61	49	40
10,01	12,00	12	118	71	56	45

**Beispiel:**  
M2925-0431EQ

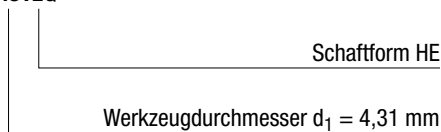

Maßangaben in mm.

Schnittwertempfehlung siehe Kapitelende.

Sonderausführungen und andere Beschichtungen auf Anfrage.

# MEGA-Drill-Composite-UDX

Vollhartmetall-Spiralbohrer  
M2915 (5xD), äußere Kühlmittelzufuhr

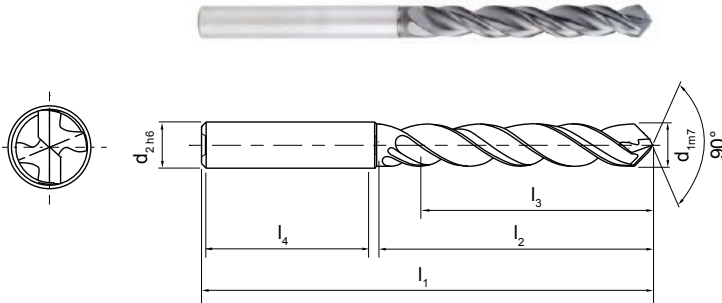

## Ausführung:

Bohrerdurchmesser:	3,00 - 12,00 mm
Bohrungstoleranz:	≥ IT 8
Beschichtung:	Diamant-Beschichtet
Schneidenanzahl:	2
Anzahl Führungsfasen:	4
Spitzenwinkel:	90°
Spiralwinkel:	35°

## Anwendung:

Für alle CFK-Werkstoffe / Problemlöser bei labilen Spannungssituationen oder dünnwandigen Bauteilen.

N	1.1	1.2	1.3	1.4	2.1	2.2	2.3	3.1	4.1	4.2	4.3	C	1.1	1.2	1.3	2.1	3.1	4.1	4.2	4.3	4.4	5.1	5.2	



## Lagerhaltige Vorzugsbaureihe in Schaftform HA

Baumaße						Schaftform HA	
d <sub>1</sub> m7	d <sub>2</sub> h6	l <sub>1</sub>	l <sub>2</sub>	l <sub>3</sub>	l <sub>4</sub>	Spezifikation	Bestell-Nr.
3,30	6	66	26	20	36	M2915-0330AQ	30396143
4,00	6	74	35	27	36	M2915-0400AQ	30396155
4,394	6	74	35	27	36	M2915-04394AQ	30634745
4,50	6	74	35	27	36	M2915-0450AQ	30396163
5,00	6	82	44	35	36	M2915-0500AQ	30396174

## Konfigurierbare Merkmale



### Durchmesser:

Durchmesser in Abstufungen von 0,01 mm frei wählbar



### Schaftform:

Schaftform: HB | HE

### Spezifikation:

M2915-[Durchmesser][Schaftform]Q

Beispiel:  
M2915-0431EQ

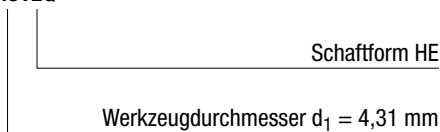

## Abmessungen konfigurierbare Baureihe

d <sub>1</sub> min.	d <sub>1</sub> max.	d <sub>2</sub> h6	l <sub>1</sub>	l <sub>2</sub>	l <sub>3</sub>	l <sub>4</sub>
3,00	3,99	6	66	26	20	36
4,00	4,99	6	74	35	27	36
5,00	6,00	6	82	44	35	36
6,01	8,00	8	91	52	40	36
8,01	10,00	10	103	60	45	40
10,01	12,00	12	118	70	52	45

Maßangaben in mm.

Schnittwertempfehlung siehe Kapitelende.

Sonderausführungen und andere Beschichtungen auf Anfrage.



# MEGA-Drill-Composite-UDX

Vollhartmetall-Spiralbohrer  
M2935 (5xD), innere Kühlmittelzufuhr

**Ausführung:**  
Bohrerdurchmesser: 6,00 - 12,00 mm  
Beschichtung: Diamant-Beschichtet  
Schneidenanzahl: 2  
Anzahl Führungsfasen: 3  
Spitzenwinkel: 90°  
Spiralwinkel: 35°

**Anwendung:**  
Für alle CFK-Werkstoffe / Problemlöser bei labilen Spannungssituationen oder dünnwandigen Bauteilen.

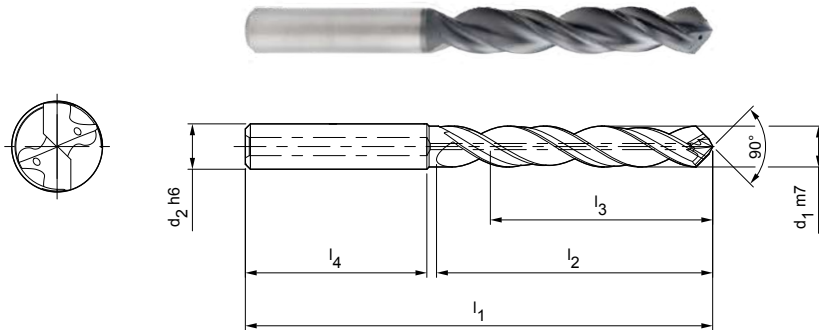

N	1.1	1.2	1.3	1.4	2.1	2.2	2.3	3.1	4.1	4.2	4.3	C	1.1	1.2	1.3	2.1	3.1	4.1	4.2	5.1	5.2	5.3	
								■				■		■	■	■							



## Lagerhaltige Vorzugsbaureihe in Schaftform HA

Baumaße						Schaftform HA	
d <sub>1</sub> m7	d <sub>2</sub> h6	l <sub>1</sub>	l <sub>2</sub>	l <sub>3</sub>	l <sub>4</sub>	Spezifikation	Bestell-Nr.
6,00	6	82	44	35	36	M2935-0600AQ	30352042
8,00	8	91	52	40	36	M2935-0800AQ	30352066
10,00	10	103	60	45	40	M2935-1000AQ	30342828

## Konfigurierbare Merkmale



**Durchmesser:**  
Durchmesser in Abstufungen von 0,01 mm frei wählbar



**Schaftform:**  
Schaftform: HB | HE

**Spezifikation:**  
M2935-[Durchmesser][Schaftform]Q

## Abmessungen konfigurierbare Baureihe

d <sub>1</sub> min.	d <sub>1</sub> max.	d <sub>2</sub> h6	l <sub>1</sub>	l <sub>2</sub>	l <sub>3</sub>	l <sub>4</sub>
6,00	6,00	6	82	44	35	36
6,01	8,00	8	91	52	40	36
8,01	10,00	10	103	60	45	40
10,01	12,00	12	118	70	52	45

**Beispiel:**  
M2935-0431EQ

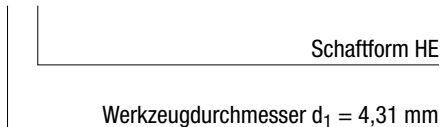

Maßangaben in mm.  
Schnittwertempfehlung siehe Kapitelende.  
Sonderausführungen und andere Beschichtungen auf Anfrage.

# MEGA-Drill-Aramid

Vollhartmetall-Spiralbohrer  
M2993 (3xD), äußere Kühlmittelzufuhr

**Ausführung:**  
Bohrerdurchmesser: 3,00 - 12,00 mm  
Beschichtung: Unbeschichtet  
Schneidenanzahl: 2  
Spitzenwinkel: 90°  
Spiralwinkel: 30°

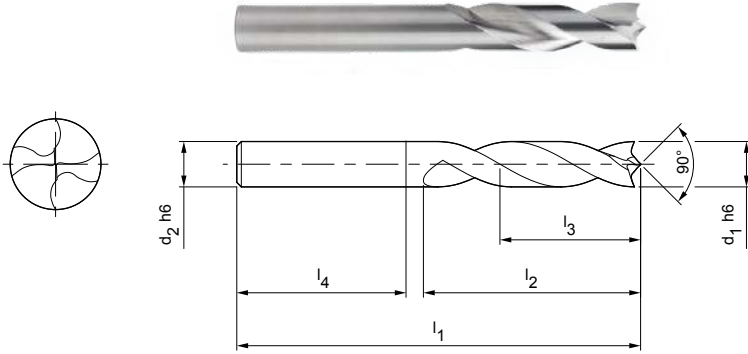

Baumaße						Schaffform HA	
d <sub>1</sub> h6	d <sub>2</sub> h6	l <sub>1</sub>	l <sub>2</sub>	l <sub>3</sub>	l <sub>4</sub>	Spezifikation	Bestell-Nr.
3,00	3	40	12	7	28	M2993-0300AU	30290554
4,00	4	55	18	12	28	M2993-0400AU	30290555
5,00	5	62	26	18	28	M2993-0500AU	30290556
6,00	6	66	28	19	36	M2993-0600AU	30290557
6,50	6,5	70	31	21	36	M2993-0650AU	30290558
7,00	7	74	34	23	36	M2993-0700AU	30290559
8,00	8	79	37	25	36	M2993-0800AU	30290560
8,50	8,5	79	37	25	40	M2993-0850AU	30290561
9,00	9	84	40	27	40	M2993-0900AU	30290562
10,00	10	89	48	31	40	M2993-1000AU	30290563
12,00	12	102	50	32	45	M2993-1200AU	30290564

Maßangaben in mm.

Schnittwertempfehlung siehe Kapitelende.

Sonderausführungen und andere Beschichtungen auf Anfrage.



# MEGA-180°-Drill-Alu

Vollhartmetall-Spiralbohrer  
M9883 (3xD), innere Kühlmittelzufuhr

## Ausführung:

Bohrerdurchmesser: 3,00 - 20,00 mm  
Bohrungstoleranz:  $\geq$  IT 9  
Beschichtung: Unbeschichtet  
Schneidenanzahl: 2  
Anzahl Führungsfasen: 4  
Spitzenwinkel: 180°  
Spiralwinkel: 30°

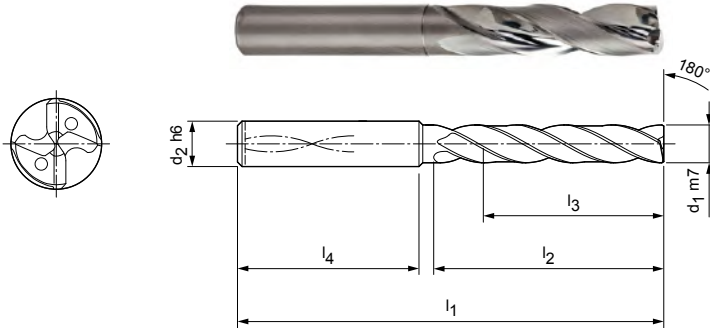

## Lagerhaltige Vorzugsbaureihe in Schaftform HA

Baumaße						Schaftform HA	
d <sub>1</sub> m7	d <sub>2</sub> h6	l <sub>1</sub>	l <sub>2</sub>	l <sub>3</sub>	l <sub>4</sub>	Spezifikation	Bestell-Nr.
3,00	6	62	20	14	36	M9883-0300AU	30286617
3,70	6	62	20	14	36	M9883-0370AU	30286624
4,00	6	66	24	17	36	M9883-0400AU	30286627
4,20	6	66	24	17	36	M9883-0420AU	30286629
4,30	6	66	24	17	36	M9883-0430AU	30286630
4,60	6	66	24	17	36	M9883-0460AU	30286633
5,00	6	66	28	20	36	M9883-0500AU	30286638
5,50	6	66	28	20	36	M9883-0550AU	30286643
5,56	6	66	28	20	36	M9883-0556AU	30463896
6,00	6	66	28	20	36	M9883-0600AU	30286649
6,50	8	79	34	24	36	M9883-0650AU	30286654
6,70	8	79	34	24	36	M9883-0670AU	30286656
7,00	8	79	34	24	36	M9883-0700AU	30286659
7,20	8	79	41	29	36	M9883-0720AU	30286661
7,40	8	79	41	29	36	M9883-0740AU	30286663
7,50	8	79	41	29	36	M9883-0750AU	30286664
7,80	8	79	41	29	36	M9883-0780AU	30286667
8,00	8	79	41	29	36	M9883-0800AU	30286669
8,50	10	89	47	35	40	M9883-0850AU	30286674
8,90	10	89	47	35	40	M9883-0890AU	30286678
9,00	10	89	47	35	40	M9883-0900AU	30286679
9,20	10	89	47	35	40	M9883-0920AU	30286681
9,80	10	89	47	35	40	M9883-0980AU	30286687
10,00	10	89	47	35	40	M9883-1000AU	30286689
11,00	12	100	53	38	45	M9883-1100AU	30286699
12,00	12	100	53	38	45	M9883-1200AU	30286709
13,00	14	105	58	41	45	M9883-1300AU	30286712
14,50	16	113	63	43	48	M9883-1450AU	30286716
17,00	18	121	71	49	48	M9883-1700AU	30286724
18,50	20	129	77	53	50	M9883-1850AU	30286728

**MEGA-180°-Drill-Alu | Vollhartmetall-Spiralbohrer M9883 (3xD), innere Kühlmittelzufuhr****Konfigurierbare Merkmale**

**Durchmesser:**  
Durchmesser in Abstufungen  
von 0,01 mm frei wählbar



**Schaftform:**  
Schaftform: HB | HE

**Spezifikation:**

M9883-[Durchmesser][Schaftform]U

**Beispiel:**  
M9883-0431EU

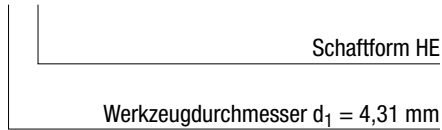
**Abmessungen konfigurierbare Baureihe**

d <sub>1</sub> min.	d <sub>1</sub> max.	d <sub>2</sub> h6	l <sub>1</sub>	l <sub>2</sub>	l <sub>3</sub>	l <sub>4</sub>
3,00	3,70	6	62	20	14	36
3,71	4,70	6	66	24	17	36
4,71	6,00	6	66	28	20	36
6,01	6,80	8	79	34	24	36
6,81	8,00	8	79	41	29	36
8,01	10,00	10	89	47	35	40
10,01	12,00	12	100	53	38	45
12,01	14,00	14	105	58	41	45
14,01	16,00	16	113	63	43	48
16,01	18,00	18	121	71	49	48
18,01	20,00	20	129	77	53	50

Maßangaben in mm.

Schnittwertempfehlung siehe Kapitelende.

Sonderausführungen und andere Beschichtungen auf Anfrage.

# MEGA-180°-Drill-Alu

Vollhartmetall-Spiralbohrer  
M9885 (5xD), innere Kühlmittelzufuhr

**Ausführung:**

Bohrerdurchmesser: 3,00 - 20,00 mm  
Bohrungstoleranz:  $\geq$  IT 9  
Beschichtung: Unbeschichtet  
Schneidenanzahl: 2  
Anzahl Führungsfasen: 4  
Spitzenwinkel: 180°  
Spiralwinkel: 30°

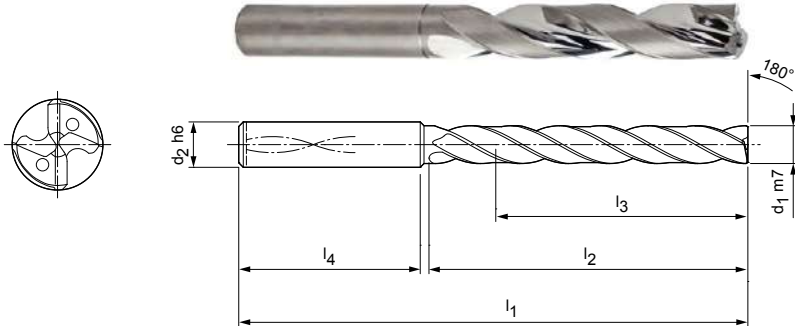

**Lagerhaltige Vorzugsbaureihe in Schaftform HA**

Baumaße						Schaftform HA	
d <sub>1</sub> m7	d <sub>2</sub> h6	l <sub>1</sub>	l <sub>2</sub>	l <sub>3</sub>	l <sub>4</sub>	Spezifikation	Bestell-Nr.
3,00	6	66	28	23	36	M9885-0300AU	30286497
3,50	6	66	28	23	36	M9885-0350AU	30286502
4,00	6	74	36	29	36	M9885-0400AU	30286507
4,10	6	74	36	29	36	M9885-0410AU	30286508
4,80	6	82	44	35	36	M9885-0480AU	30286517
5,00	6	82	44	35	36	M9885-0500AU	30286519
5,60	6	82	44	35	36	M9885-0560AU	30286526
6,00	6	82	44	35	36	M9885-0600AU	30286530
6,50	8	91	53	43	36	M9885-0650AU	30286535
7,00	8	91	53	43	36	M9885-0700AU	30286540
7,50	8	91	53	43	36	M9885-0750AU	30286546
8,00	8	91	53	43	36	M9885-0800AU	30286551
8,20	10	103	61	49	40	M9885-0820AU	30286553
8,50	10	103	61	49	40	M9885-0850AU	30286556
9,00	10	103	61	49	40	M9885-0900AU	30286561
9,30	10	103	61	49	40	M9885-0930AU	30286564
10,00	10	103	61	49	40	M9885-1000AU	30286571
12,00	12	116	69	54	45	M9885-1200AU	30286591
13,00	14	122	75	58	45	M9885-1300AU	30286594
14,00	14	122	75	58	45	M9885-1400AU	30286598
15,00	16	131	81	61	48	M9885-1500AU	30286601
15,70	16	131	81	61	48	M9885-1570AU	31237342
20,00	20	151	99	75	50	M9885-2000AU	30286616

**MEGA-180°-Drill-Alu | Vollhartmetall-Spiralbohrer M9885 (5xD), innere Kühlmittelzufuhr****Konfigurierbare Merkmale****Durchmesser:**

Durchmesser in Abstufungen  
von 0,01 mm frei wählbar

**Schaftform:**

Schaftform: HB | HE

**Spezifikation:**

M9885-[Durchmesser][Schaftform]U

**Abmessungen konfigurierbare Baureihe**

d <sub>1</sub> min.	d <sub>1</sub> max.	d <sub>2</sub> h6	l <sub>1</sub>	l <sub>2</sub>	l <sub>3</sub>	l <sub>4</sub>
3,00	3,70	6	66	28	23	36
3,71	4,70	6	74	36	29	36
4,71	6,00	6	82	44	35	36
6,01	8,00	8	91	53	43	36
8,01	10,00	10	103	61	49	40
10,01	12,00	12	116	69	54	45
12,01	14,00	14	122	75	58	45
14,01	16,00	16	131	81	61	48
16,01	18,00	18	141	91	69	48
18,01	20,00	20	151	99	75	50

**Beispiel:**

M9885-0431EU

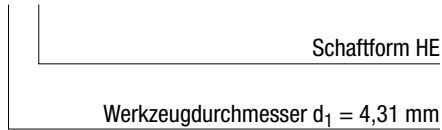

Maßangaben in mm.

Schnittwertempfehlung siehe Kapitelende.

Sonderausführungen und andere Beschichtungen auf Anfrage.

# ECU-G-Drill

Vollhartmetallbohrer, geradegenutet  
M2605 (5xD), innere Kühlmittelzufuhr

**Ausführung:**

Bohrerdurchmesser: 4,80 - 7,50 mm  
Bohrungstoleranz: ≥ IT 9  
Beschichtung: Unbeschichtet  
Schneidenanzahl: 2  
Anzahl Führungsfasen: 4  
Spitzenwinkel: 130°

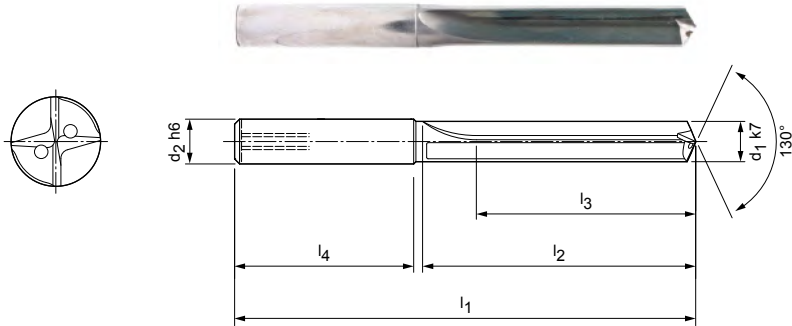

**Lagerhaltige Vorzugsbaureihe in Schaftform HA**

Baumaße						Schaftform HA	
d <sub>1</sub> k7	d <sub>2</sub> h6	l <sub>1</sub>	l <sub>2</sub>	l <sub>3</sub>	l <sub>4</sub>	Spezifikation	Bestell-Nr.
4,80	6	82	44	35	36	M2605-0480AU	30060601
5,50	6	82	44	35	36	M2605-0550AU	30072699
5,70	6	82	44	35	36	M2605-0570AU	30060612
5,80	6	82	44	35	36	M2605-0580AU	30073818
6,80	8	91	53	43	36	M2605-0680AU	30072205
7,40	8	91	53	43	36	M2605-0740AU	30063212
7,50	8	91	53	43	36	M2605-0750AU	30072831

**Konfigurierbare Merkmale**



**Schaftform:**  
Schaftform: HB | HE



**Spezifikation:**  
M2605-0580[Schaftform]U

Beispiel:  
M2605-0580EU

Schaftform HE

Maßangaben in mm.  
Schnittwertempfehlung siehe Kapitelende.  
Sonderausführungen und andere Beschichtungen auf Anfrage.



# ECU-G-Drill

Vollhartmetallbohrer, geradegenutet  
M2608 (8xD), innere Kühlmittelzufuhr

**Ausführung:**

Bohrerdurchmesser: 5,80 - 11,60 mm  
Bohrungstoleranz:  $\geq$  IT 9  
Beschichtung: Unbeschichtet  
Schneidenanzahl: 2  
Anzahl Führungsfasen: 4  
Spitzenwinkel: 130°

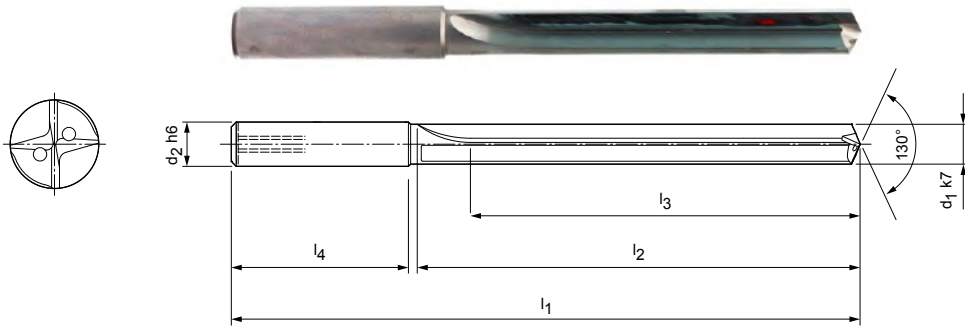

**Lagerhaltige Vorzugsbaureihe in Schaftform HA**

Baumaße						Schaftform HA	
d <sub>1</sub> k7	d <sub>2</sub> h6	l <sub>1</sub>	l <sub>2</sub>	l <sub>3</sub>	l <sub>4</sub>	Spezifikation	Bestell-Nr.
5,80	6	95	57	48	36	M2608-0580AU	30060741
11,60	12	162	114	96	45	M2608-1160AU	30060806

**Konfigurierbare Merkmale**

**Schaftform:**  
Schaftform: HB | HE

**Spezifikation:**  
M2608-0580[Schaftform]U

Beispiel:  
M2608-0580EU

Schaftform HE

Maßangaben in mm.  
Schnittwertempfehlung siehe Kapitelende.  
Sonderausführungen und andere Beschichtungen auf Anfrage.

# Schnittwertempfehlung für Vollhartmetallbohrer

Vorschub und Schnittgeschwindigkeit

## Tritan-Drill-Uni-Plus | M9535P, M9538P, M9542P

MZG*	Werkstoff	Festigkeit/Härte [N/mm <sup>2</sup> ] [HRC]
P	P1.1 Bau-, Automaten-, Einsatz- und Vergütungsstähle, unlegiert	< 700
	P1.2 Bau-, Automaten-, Einsatz- und Vergütungsstähle, unlegiert	< 1.200
	P2.1 Nitrier-, Einsatz- und Vergütungsstähle, legiert	< 900
	P2.2 Nitrier-, Einsatz- und Vergütungsstähle, legiert	< 1.400
	P3.1 Werkzeug-, Wälzlager-, Feder- und Schnellarbeitsstähle**	< 800
	P3.2 Werkzeug-, Wälzlager-, Feder- und Schnellarbeitsstähle**	< 1.000
	P3.3 Werkzeug-, Wälzlager-, Feder- und Schnellarbeitsstähle**	< 1.500
	P5.1 Stahlguss	
M	M1.1 Rostfreie Stähle, austenitisch	< 700
	M1.2 Rostfreie Stähle, ferritisch/austenitisch (Duplex)	< 1.000
K	K1.1 Gusseisen mit Lamellengraphit (Grauguss), GJL	< 300
	K2.1 Gusseisen mit Kugelgraphit, GJS	< 500
	K2.2 Gusseisen mit Kugelgraphit, GJS	≤ 800
	K2.3 Gusseisen mit Kugelgraphit, GJS	> 800
	K3.1 Gusseisen mit Vermiculargraphit, GJV; Temperguss, GJM	< 500
	K3.2 Gusseisen mit Vermiculargraphit, GJV; Temperguss, GJM	> 500
N	N1.1 Aluminium, unlegiert und legiert < 3 % Si	
	N1.2 Aluminium, legiert ≤ 7 % Si	
	N1.3 Aluminium, legiert > 7-12 % Si	
	N1.4 Aluminium, legiert > 12 % Si	
	N2.1 Kupfer, unlegiert und niedriglegiert	< 300
	N2.2 Kupfer, legiert	> 300
	N2.3 Messing, Bronze, Rotguss	< 1.200

## MEGA-Speed-Drill-Uni | M9103, M9105, M9108

MZG*	Werkstoff	Festigkeit/Härte [N/mm <sup>2</sup> ] [HRC]
P	P1.1 Bau-, Automaten-, Einsatz- und Vergütungsstähle, unlegiert	< 700
	P1.2 Bau-, Automaten-, Einsatz- und Vergütungsstähle, unlegiert	< 1.200
	P2.1 Nitrier-, Einsatz- und Vergütungsstähle, legiert	< 900
	P2.2 Nitrier-, Einsatz- und Vergütungsstähle, legiert	< 1.400
	P3.1 Werkzeug-, Wälzlager-, Feder- und Schnellarbeitsstähle**	< 800
	P3.2 Werkzeug-, Wälzlager-, Feder- und Schnellarbeitsstähle**	< 1.000
	P3.3 Werkzeug-, Wälzlager-, Feder- und Schnellarbeitsstähle**	< 1.500
	P4.1 Rostfreie Stähle, ferritisch und martensitisch	
	P5.1 Stahlguss	
	P6.1 Rostfreier Stahlguss, ferritisch und martensitisch	
K	K1.1 Gusseisen mit Lamellengraphit (Grauguss), GJL	< 300
	K2.1 Gusseisen mit Kugelgraphit, GJS	< 500
	K2.2 Gusseisen mit Kugelgraphit, GJS	≤ 800
	K2.3 Gusseisen mit Kugelgraphit, GJS	> 800
	K3.1 Gusseisen mit Vermiculargraphit, GJV; Temperguss, GJM	< 500
	K3.2 Gusseisen mit Vermiculargraphit, GJV; Temperguss, GJM	> 500

\* MILLER Zerspanungsgruppen

\*\* Wenn die Legierungsbestandteile Cr, Mo, Ni, V, W in Summe > 8 %, dann die nächst höhere MILLER Zerspanungsgruppe wählen.

	Schnittgeschwindigkeit $v_c$ [m/min]				Vorschub $f$ [mm] bei Bohrerdurchmesser					
	Innenkühlung	Außenkühlung	MMS	Luft	4,00	5,50	7,50	10,50	14,50	20,00
	<b>115</b>	<b>105</b>	<b>105</b>		0,22	0,27	0,34	0,42	0,51	0,59
	<b>105</b>	<b>85</b>	<b>85</b>		0,27	0,34	0,42	0,53	0,64	0,74
	<b>115</b>	<b>100</b>	<b>100</b>		0,25	0,32	0,40	0,50	0,60	0,70
	<b>80</b>	<b>70</b>	<b>70</b>		0,21	0,26	0,32	0,40	0,48	0,55
	<b>85</b>	<b>75</b>	<b>75</b>		0,23	0,29	0,36	0,45	0,54	0,63
	<b>70</b>	<b>65</b>	<b>65</b>		0,19	0,24	0,30	0,37	0,44	0,51
	<b>70</b>	<b>50</b>	<b>60</b>		0,16	0,19	0,24	0,29	0,34	0,40
	<b>115</b>	<b>100</b>	<b>100</b>		0,25	0,32	0,40	0,50	0,60	0,70
	<b>55</b>	<b>35</b>	<b>35</b>		0,11	0,14	0,18	0,22	0,27	0,31
	<b>140</b>	<b>100</b>	<b>100</b>	<b>100</b>	0,31	0,41	0,53	0,68	0,84	0,98
	<b>185</b>	<b>115</b>	<b>140</b>	<b>140</b>	0,30	0,39	0,50	0,64	0,78	0,91
	<b>115</b>	<b>85</b>	<b>85</b>		0,27	0,35	0,44	0,55	0,67	0,78
	<b>70</b>	<b>45</b>	<b>60</b>		0,14	0,18	0,22	0,28	0,33	0,38
	<b>105</b>	<b>90</b>	<b>90</b>		0,29	0,37	0,47	0,59	0,72	0,84
	<b>90</b>	<b>80</b>	<b>80</b>		0,25	0,31	0,38	0,48	0,57	0,66
	<b>345</b>	<b>230</b>	<b>290</b>		0,22	0,27	0,34	0,42	0,51	0,59
	<b>290</b>	<b>205</b>	<b>230</b>		0,27	0,35	0,44	0,55	0,67	0,78
	<b>255</b>	<b>175</b>	<b>205</b>		0,27	0,35	0,44	0,55	0,67	0,78
	<b>205</b>	<b>140</b>	<b>175</b>		0,27	0,35	0,44	0,55	0,67	0,78
	<b>140</b>	<b>105</b>			0,20	0,26	0,33	0,41	0,50	0,58
<b>230</b>	<b>185</b>	<b>185</b>	<b>140</b>	0,31	0,41	0,53	0,68	0,84	0,98	

	Schnittgeschwindigkeit $v_c$ [m/min]				Vorschub $f$ [mm] bei Bohrerdurchmesser					
	Innenkühlung	Außenkühlung	MMS	Luft	3,00	4,50	6,50	9,50	14,00	20,00
	<b>170</b>	<b>155</b>	<b>155</b>		0,11	0,14	0,18	0,23	0,30	0,36
	<b>155</b>	<b>130</b>	<b>130</b>		0,14	0,18	0,22	0,29	0,37	0,45
	<b>170</b>	<b>145</b>	<b>145</b>		0,13	0,17	0,21	0,27	0,35	0,43
	<b>120</b>	<b>100</b>	<b>100</b>		0,11	0,14	0,17	0,22	0,28	0,34
	<b>130</b>	<b>110</b>	<b>110</b>		0,11	0,15	0,19	0,25	0,32	0,38
	<b>115</b>	<b>100</b>	<b>95</b>		0,10	0,14	0,17	0,22	0,28	0,35
	<b>100</b>	<b>75</b>	<b>85</b>		0,10	0,13	0,16	0,20	0,26	0,31
	<b>100</b>	<b>75</b>	<b>85</b>		0,08	0,10	0,13	0,16	0,21	0,25
	<b>170</b>	<b>145</b>	<b>145</b>		0,13	0,17	0,21	0,27	0,35	0,43
	<b>100</b>	<b>75</b>	<b>85</b>		0,08	0,10	0,13	0,16	0,21	0,25
	<b>150</b>	<b>105</b>	<b>105</b>	<b>105</b>	0,13	0,19	0,26	0,35	0,45	0,54
	<b>200</b>	<b>125</b>	<b>150</b>	<b>150</b>	0,13	0,18	0,25	0,33	0,42	0,50
	<b>125</b>	<b>95</b>	<b>95</b>		0,12	0,16	0,22	0,28	0,36	0,43
	<b>75</b>	<b>50</b>	<b>65</b>		0,09	0,12	0,15	0,19	0,24	0,28
	<b>115</b>	<b>100</b>	<b>100</b>		0,13	0,18	0,23	0,31	0,39	0,46
	<b>100</b>	<b>90</b>	<b>90</b>		0,11	0,15	0,19	0,25	0,31	0,36

Die angegebenen Schnittwerte sind Richtwerte.

Die für den jeweiligen Bearbeitungsfall optimalen Daten sollten im Versuch oder während der Bearbeitung ermittelt werden.

# Schnittwertempfehlung für Vollhartmetallbohrer

Vorschub und Schnittgeschwindigkeit

## ECU-Drill-Uni | M6804, M6704, M6806

MZG*	Werkstoff	Festigkeit/Härte [N/mm <sup>2</sup> ] [HRC]
P	P1.1 Bau-, Automaten-, Einsatz- und Vergütungsstähle, unlegiert	< 700
	P1.2 Bau-, Automaten-, Einsatz- und Vergütungsstähle, unlegiert	< 1.200
	P2.1 Nitrier-, Einsatz- und Vergütungsstähle, legiert	< 900
	P2.2 Nitrier-, Einsatz- und Vergütungsstähle, legiert	< 1.400
	P3.1 Werkzeug-, Wälzlager-, Feder- und Schnellarbeitsstähle**	< 800
	P3.2 Werkzeug-, Wälzlager-, Feder- und Schnellarbeitsstähle**	< 1.000
	P3.3 Werkzeug-, Wälzlager-, Feder- und Schnellarbeitsstähle**	< 1.500
	P5.1 Stahlguss	
M	M1.1 Rostfreie Stähle, austenitisch	< 700
	M1.2 Rostfreie Stähle, ferritisch/austenitisch (Duplex)	< 1.000
	M2.1 Rostfreier Stahlguss, austenitisch	< 700
	M3.1 Rostfreier Stahlguss, ferritisch/austenitisch (Duplex)	< 1.000
K	K2.1 Gusseisen mit Kugelgraphit, GJS	< 500
	K2.2 Gusseisen mit Kugelgraphit, GJS	≤ 800
	K2.3 Gusseisen mit Kugelgraphit, GJS	> 800

## MEGA-Drill-Steel-Plus | M2003P, M2103P, M2005P, M2105P, M2108P

MZG*	Werkstoff	Festigkeit/Härte [N/mm <sup>2</sup> ] [HRC]
P	P1.1 Bau-, Automaten-, Einsatz- und Vergütungsstähle, unlegiert	< 700
	P1.2 Bau-, Automaten-, Einsatz- und Vergütungsstähle, unlegiert	< 1.200
	P2.1 Nitrier-, Einsatz- und Vergütungsstähle, legiert	< 900
	P2.2 Nitrier-, Einsatz- und Vergütungsstähle, legiert	< 1.400
	P3.1 Werkzeug-, Wälzlager-, Feder- und Schnellarbeitsstähle**	< 800
	P3.2 Werkzeug-, Wälzlager-, Feder- und Schnellarbeitsstähle**	< 1.000
	P3.3 Werkzeug-, Wälzlager-, Feder- und Schnellarbeitsstähle**	< 1.500
	P4.1 Rostfreie Stähle, ferritisch und martensitisch	
	P5.1 Stahlguss	
	P6.1 Rostfreier Stahlguss, ferritisch und martensitisch	
K	K1.1 Gusseisen mit Lamellengraphit (Grauguss), GJL	< 300
	K2.1 Gusseisen mit Kugelgraphit, GJS	< 500
	K2.2 Gusseisen mit Kugelgraphit, GJS	≤ 800
	K2.3 Gusseisen mit Kugelgraphit, GJS	> 800
	K3.1 Gusseisen mit Vermiculargraphit, GJV; Temperguss, GJM	< 500
	K3.2 Gusseisen mit Vermiculargraphit, GJV; Temperguss, GJM	> 500
H	H1.1 Gehärteter Stahl/Stahlguss	< 44
	H1.2 Gehärteter Stahl/Stahlguss	< 55

\* MILLER Zerspanungsgruppen

\*\* Wenn die Legierungsbestandteile Cr, Mo, Ni, V, W in Summe > 8 %, dann die nächst höhere MILLER Zerspanungsgruppe wählen.

	Schnittgeschwindigkeit $v_c$ [m/min]				Vorschub $f$ [mm] bei Bohrerdurchmesser					
	Innenkühlung	Außenkühlung	MMS	Luft	1,00	1,82	3,31	6,03	10,99	20,00
	<b>75</b>	<b>70</b>	<b>70</b>		0,03	0,05	0,07	0,10	0,16	0,21
	<b>70</b>	<b>55</b>	<b>55</b>		0,04	0,06	0,08	0,13	0,20	0,27
	<b>75</b>	<b>65</b>	<b>65</b>		0,04	0,05	0,08	0,12	0,18	0,25
	<b>55</b>	<b>45</b>	<b>45</b>		0,04	0,05	0,07	0,10	0,15	0,20
	<b>55</b>	<b>50</b>	<b>50</b>		0,03	0,05	0,07	0,11	0,17	0,23
	<b>45</b>	<b>40</b>	<b>40</b>		0,03	0,04	0,06	0,09	0,14	0,18
	<b>45</b>	<b>35</b>	<b>40</b>		0,03	0,04	0,05	0,07	0,11	0,14
	<b>75</b>	<b>65</b>	<b>65</b>		0,04	0,05	0,08	0,12	0,18	0,25
	<b>45</b>	<b>30</b>	<b>30</b>		0,03	0,04	0,06	0,09	0,14	0,19
	<b>45</b>	<b>25</b>	<b>25</b>		0,02	0,03	0,05	0,08	0,12	0,16
	<b>45</b>	<b>30</b>	<b>30</b>		0,03	0,04	0,06	0,09	0,14	0,19
	<b>45</b>	<b>25</b>	<b>25</b>		0,02	0,03	0,05	0,08	0,12	0,16
	<b>120</b>	<b>75</b>	<b>90</b>	<b>90</b>	0,05	0,07	0,12	0,19	0,30	0,41
	<b>75</b>	<b>55</b>	<b>55</b>		0,04	0,07	0,11	0,17	0,26	0,35

	Schnittgeschwindigkeit $v_c$ [m/min]				Vorschub $f$ [mm] bei Bohrerdurchmesser					
	Innenkühlung	Außenkühlung	MMS	Luft	3,00	4,50	6,50	9,50	14,00	20,00
	<b>110</b>	<b>100</b>	<b>100</b>		0,10	0,13	0,17	0,22	0,28	0,33
	<b>100</b>	<b>85</b>	<b>85</b>		0,12	0,16	0,21	0,27	0,34	0,41
	<b>110</b>	<b>95</b>	<b>95</b>		0,11	0,15	0,20	0,26	0,33	0,38
	<b>75</b>	<b>65</b>	<b>65</b>		0,10	0,13	0,16	0,21	0,26	0,30
	<b>85</b>	<b>70</b>	<b>70</b>		0,10	0,14	0,18	0,23	0,29	0,35
	<b>65</b>	<b>60</b>	<b>60</b>		0,09	0,12	0,15	0,19	0,24	0,28
	<b>65</b>	<b>50</b>	<b>55</b>		0,07	0,09	0,12	0,15	0,19	0,22
	<b>65</b>	<b>50</b>	<b>55</b>		0,07	0,09	0,12	0,15	0,19	0,23
	<b>110</b>	<b>95</b>	<b>95</b>		0,11	0,15	0,20	0,26	0,33	0,38
	<b>65</b>	<b>50</b>	<b>55</b>		0,07	0,09	0,12	0,15	0,19	0,23
	<b>120</b>	<b>85</b>	<b>85</b>	<b>85</b>	0,13	0,19	0,26	0,35	0,45	0,54
	<b>160</b>	<b>100</b>	<b>120</b>	<b>120</b>	0,13	0,18	0,25	0,33	0,42	0,50
	<b>100</b>	<b>75</b>	<b>75</b>		0,12	0,16	0,22	0,28	0,36	0,43
	<b>60</b>	<b>40</b>	<b>50</b>		0,09	0,12	0,15	0,19	0,24	0,28
	<b>90</b>	<b>80</b>	<b>80</b>		0,13	0,18	0,23	0,31	0,39	0,46
	<b>80</b>	<b>70</b>	<b>70</b>		0,11	0,15	0,19	0,25	0,31	0,36
	<b>90</b>	<b>90</b>	<b>90</b>		0,09	0,12	0,15	0,19	0,24	0,28
	<b>25</b>	<b>25</b>	<b>25</b>		0,05	0,06	0,08	0,11	0,14	0,16

Die angegebenen Schnittwerte sind Richtwerte.

Die für den jeweiligen Bearbeitungsfall optimalen Daten sollten im Versuch oder während der Bearbeitung ermittelt werden.

# Schnittwertempfehlung für Vollhartmetallbohrer

Vorschub und Schnittgeschwindigkeit

## MEGA-Quadro-Drill-Plus I M2075P, M2175P, M2178P, M2182P

MZG*	Werkstoff		Festigkeit/Härte [N/mm <sup>2</sup> ] [HRC]
P	P1	P1.1 Bau-, Automaten-, Einsatz- und Vergütungsstähle, unlegiert	< 700
		P1.2 Bau-, Automaten-, Einsatz- und Vergütungsstähle, unlegiert	< 1.200
	P2	P2.1 Nitrier-, Einsatz- und Vergütungsstähle, legiert	< 900
		P2.2 Nitrier-, Einsatz- und Vergütungsstähle, legiert	< 1.400
	P3	P3.1 Werkzeug-, Wälzlager-, Feder- und Schnellarbeitsstähle*	< 800
		P3.2 Werkzeug-, Wälzlager-, Feder- und Schnellarbeitsstähle*	< 1.000
		P3.3 Werkzeug-, Wälzlager-, Feder- und Schnellarbeitsstähle*	< 1.500
	P5	P5.1 Stahlguss	
	K	K1	K1.1 Gusseisen mit Lamellengraphit (Grauguss), GJL
K2.1 Gusseisen mit Kugelgraphit, GJS			< 500
K2		K2.2 Gusseisen mit Kugelgraphit, GJS	≤ 800
		K2.3 Gusseisen mit Kugelgraphit, GJS	> 800
K3		K3.1 Gusseisen mit Vermiculargraphit, GJV; Temperguss, GJM	< 500
		K3.2 Gusseisen mit Vermiculargraphit, GJV; Temperguss, GJM	> 500

## MICRO-Drill-Steel I M1925, M1928, M1932

MZG*	Werkstoff		Festigkeit/Härte [N/mm <sup>2</sup> ] [HRC]
P	P1	P1.1 Bau-, Automaten-, Einsatz- und Vergütungsstähle, unlegiert	< 700
		P1.2 Bau-, Automaten-, Einsatz- und Vergütungsstähle, unlegiert	< 1.200
	P2	P2.1 Nitrier-, Einsatz- und Vergütungsstähle, legiert	< 900
		P2.2 Nitrier-, Einsatz- und Vergütungsstähle, legiert	< 1.400
	P3	P3.1 Werkzeug-, Wälzlager-, Feder- und Schnellarbeitsstähle*	< 800
		P3.2 Werkzeug-, Wälzlager-, Feder- und Schnellarbeitsstähle*	< 1.000
		P3.3 Werkzeug-, Wälzlager-, Feder- und Schnellarbeitsstähle*	< 1.500
	P5	P5.1 Stahlguss	
	M	M1	M1.1 Rostfreie Stähle, austenitisch
M1.2 Rostfreie Stähle, ferritisch/austenitisch (Duplex)			< 1000
K	K1	K1.1 Gusseisen mit Lamellengraphit (Grauguss), GJL	< 300
		K2.1 Gusseisen mit Kugelgraphit, GJS	< 500
	K2	K2.2 Gusseisen mit Kugelgraphit, GJS	≤ 800
		K2.3 Gusseisen mit Kugelgraphit, GJS	> 800
	K3	K3.1 Gusseisen mit Vermiculargraphit, GJV; Temperguss, GJM	< 500
		K3.2 Gusseisen mit Vermiculargraphit, GJV; Temperguss, GJM	> 500

\* MILLER Zerspanungsgruppen

\*\* Wenn die Legierungsbestandteile Cr, Mo, Ni, V, W in Summe > 8 %, dann die nächst höhere MILLER Zerspanungsgruppe wählen.

	Schnittgeschwindigkeit $v_c$ [m/min]				Vorschub $f$ [mm] bei Bohrerdurchmesser					
	Innenkühlung	Außenkühlung	MMS	Luft	4,00	5,50	7,50	10,50	14,50	20,00
	<b>110</b>	<b>100</b>	<b>100</b>		0,10	0,13	0,17	0,22	0,28	0,33
	<b>100</b>	<b>85</b>	<b>85</b>		0,12	0,16	0,21	0,27	0,34	0,41
	<b>110</b>	<b>95</b>	<b>95</b>		0,11	0,15	0,20	0,26	0,33	0,38
	<b>75</b>	<b>65</b>	<b>65</b>		0,10	0,13	0,16	0,21	0,26	0,30
	<b>85</b>	<b>70</b>	<b>70</b>		0,10	0,14	0,18	0,23	0,29	0,35
	<b>65</b>	<b>60</b>	<b>60</b>		0,09	0,12	0,15	0,19	0,24	0,28
	<b>65</b>	<b>50</b>	<b>55</b>		0,07	0,09	0,12	0,15	0,19	0,22
	<b>110</b>	<b>95</b>	<b>95</b>		0,11	0,15	0,20	0,26	0,33	0,38
	<b>130</b>	<b>95</b>	<b>95</b>	<b>95</b>	0,13	0,19	0,26	0,35	0,45	0,54
	<b>175</b>	<b>110</b>	<b>130</b>	<b>130</b>	0,13	0,18	0,25	0,33	0,42	0,50
	<b>110</b>	<b>85</b>	<b>85</b>		0,12	0,16	0,22	0,28	0,36	0,43
	<b>65</b>	<b>45</b>	<b>55</b>		0,09	0,12	0,15	0,19	0,24	0,28
	<b>100</b>	<b>90</b>	<b>90</b>		0,13	0,18	0,23	0,31	0,39	0,46
	<b>90</b>	<b>75</b>	<b>75</b>		0,11	0,15	0,19	0,25	0,31	0,36

	Schnittgeschwindigkeit $v_c$ [m/min]				Vorschub $f$ [mm] bei Bohrerdurchmesser					
	Innenkühlung	Außenkühlung	MMS	Luft	4,00	5,50	7,50	10,50	14,50	20,00
	<b>80</b>	<b>70</b>	<b>70</b>		0,04	0,04	0,05	0,06	0,07	0,08
	<b>70</b>	<b>60</b>	<b>60</b>		0,04	0,05	0,06	0,07	0,08	0,10
	<b>80</b>	<b>70</b>	<b>70</b>		0,04	0,05	0,06	0,07	0,08	0,09
	<b>55</b>	<b>50</b>	<b>50</b>		0,04	0,05	0,05	0,06	0,07	0,08
	<b>60</b>	<b>50</b>	<b>50</b>		0,04	0,04	0,05	0,06	0,07	0,08
	<b>50</b>	<b>45</b>	<b>45</b>		0,04	0,04	0,04	0,05	0,06	0,07
	<b>50</b>	<b>35</b>	<b>40</b>		0,03	0,04	0,04	0,05	0,05	0,06
	<b>80</b>	<b>70</b>	<b>70</b>		0,04	0,05	0,06	0,07	0,08	0,09
	<b>40</b>	<b>25</b>	<b>25</b>		0,03	0,03	0,03	0,04	0,05	0,06
	<b>95</b>	<b>70</b>	<b>70</b>	<b>70</b>	0,03	0,04	0,05	0,06	0,08	0,11
	<b>130</b>	<b>80</b>	<b>95</b>	<b>95</b>	0,04	0,05	0,06	0,07	0,09	0,11
	<b>80</b>	<b>60</b>	<b>60</b>		0,04	0,05	0,05	0,07	0,08	0,10
	<b>70</b>	<b>65</b>	<b>65</b>		0,04	0,05	0,06	0,07	0,09	0,11
	<b>65</b>	<b>55</b>	<b>55</b>		0,04	0,05	0,06	0,07	0,08	0,09

Die angegebenen Schnittwerte sind Richtwerte.

Die für den jeweiligen Bearbeitungsfall optimalen Daten sollten im Versuch oder während der Bearbeitung ermittelt werden.

# Schnittwertempfehlung für Vollhartmetallbohrer

Vorschub und Schnittgeschwindigkeit

## MEGA-Drill-Hardened I M1603

MZG*	Werkstoff		Festigkeit/Härte [N/mm <sup>2</sup> ] [HRC]
H1	H1.1	Gehärteter Stahl/Stahlguss	< 44
	H1.2	Gehärteter Stahl/Stahlguss	< 55
H2	H2.1	Gehärteter Stahl/Stahlguss	< 60
	H2.2	Gehärteter Stahl/Stahlguss	< 65
	H2.3	Gehärteter Stahl/Stahlguss	< 68

## Tritan-Drill-Steel I M9933, M9935, M9938, M9942

MZG*	Werkstoff		Festigkeit/Härte [N/mm <sup>2</sup> ] [HRC]
P1	P1.1	Bau-, Automaten-, Einsatz- und Vergütungsstähle, unlegiert	< 700
	P1.2	Bau-, Automaten-, Einsatz- und Vergütungsstähle, unlegiert	< 1.200
P2	P2.1	Nitrier-, Einsatz- und Vergütungsstähle, legiert	< 900
	P2.2	Nitrier-, Einsatz- und Vergütungsstähle, legiert	< 1.400
P3	P3.1	Werkzeug-, Wälzlager-, Feder- und Schnellarbeitsstähle**	< 800
	P3.2	Werkzeug-, Wälzlager-, Feder- und Schnellarbeitsstähle**	< 1.000
	P3.3	Werkzeug-, Wälzlager-, Feder- und Schnellarbeitsstähle**	< 1.500
P5	P5.1	Stahlguss	
M1	M1.1	Rostfreie Stähle, austenitisch	< 700
	M1.2	Rostfreie Stähle, ferritisch/austenitisch (Duplex)	< 1.000
K1	K1.1	Gusseisen mit Lamellengraphit (Grauguss), GJL	< 300
	K2.1	Gusseisen mit Kugelgraphit, GJS	< 500
K2	K2.2	Gusseisen mit Kugelgraphit, GJS	≤ 800
	K2.3	Gusseisen mit Kugelgraphit, GJS	> 800
K3	K3.1	Gusseisen mit Vermiculargraphit, GJV; Temperguss, GJM	< 500
	K3.2	Gusseisen mit Vermiculargraphit, GJV; Temperguss, GJM	> 500

\* MILLER Zerspanungsgruppen

\*\* Wenn die Legierungsbestandteile Cr, Mo, Ni, V, W in Summe > 8 %, dann die nächst höhere MILLER Zerspanungsgruppe wählen.



	Schnittgeschwindigkeit $v_c$ [m/min]				Vorschub $f$ [mm] bei Bohrerdurchmesser					
	Innenkühlung	Außenkühlung	MMS	Luft	2,50	3,62	5,25	7,61	11,04	16,00
	<b>80</b>	<b>80</b>	<b>80</b>		0,07	0,09	0,11	0,02	0,19	0,20
	<b>30</b>	<b>30</b>	<b>30</b>		0,05	0,06	0,08	0,10	0,13	0,16
		<b>30</b>	<b>30</b>		0,04	0,05	0,07	0,09	0,11	0,13
		<b>20</b>	<b>20</b>		0,03	0,04	0,05	0,06	0,08	0,09
		<b>15</b>	<b>15</b>		0,03	0,04	0,05	0,06	0,08	0,09

	Schnittgeschwindigkeit $v_c$ [m/min]				Vorschub $f$ [mm] bei Bohrerdurchmesser					
	Innenkühlung	Außenkühlung	MMS	Luft	4,00	5,50	7,50	10,50	14,50	20,00
	<b>115</b>	<b>105</b>	<b>105</b>		0,24	0,30	0,37	0,46	0,56	0,65
	<b>105</b>	<b>85</b>	<b>85</b>		0,30	0,37	0,46	0,58	0,70	0,81
	<b>115</b>	<b>100</b>	<b>100</b>		0,28	0,35	0,44	0,55	0,66	0,77
	<b>80</b>	<b>70</b>	<b>70</b>		0,24	0,29	0,36	0,44	0,53	0,61
	<b>85</b>	<b>75</b>	<b>75</b>		0,25	0,31	0,39	0,49	0,60	0,69
	<b>70</b>	<b>65</b>	<b>65</b>		0,21	0,26	0,33	0,41	0,49	0,56
	<b>70</b>	<b>50</b>	<b>60</b>		0,18	0,21	0,26	0,32	0,38	0,43
	<b>115</b>	<b>100</b>	<b>100</b>		0,28	0,35	0,44	0,55	0,66	0,77
	<b>55</b>	<b>35</b>	<b>35</b>		0,11	0,14	0,18	0,22	0,27	0,31
	<b>140</b>	<b>100</b>	<b>100</b>	<b>100</b>	0,34	0,45	0,58	0,75	0,92	1,08
	<b>185</b>	<b>115</b>	<b>140</b>	<b>140</b>	0,34	0,43	0,55	0,70	0,85	1,00
	<b>115</b>	<b>85</b>	<b>85</b>		0,30	0,38	0,48	0,61	0,74	0,86
	<b>70</b>	<b>45</b>	<b>60</b>		0,16	0,20	0,25	0,31	0,38	0,44
	<b>105</b>	<b>90</b>	<b>90</b>		0,32	0,41	0,52	0,65	0,79	0,92
	<b>90</b>	<b>80</b>	<b>80</b>		0,27	0,34	0,42	0,52	0,63	0,73

Die angegebenen Schnittwerte sind Richtwerte.

Die für den jeweiligen Bearbeitungsfall optimalen Daten sollten im Versuch oder während der Bearbeitung ermittelt werden.

# Schnittwertempfehlung für Vollhartmetallbohrer

Vorschub und Schnittgeschwindigkeit

## MEGA-Speed-Drill-Steel | M9923, M9925, M9928, M9932

MZG*	Werkstoff	Festigkeit/Härte [N/mm <sup>2</sup> ] [HRC]
P	P1.1 Bau-, Automaten-, Einsatz- und Vergütungsstähle, unlegiert	< 700
	P1.2 Bau-, Automaten-, Einsatz- und Vergütungsstähle, unlegiert	< 1.200
	P2.1 Nitrier-, Einsatz- und Vergütungsstähle, legiert	< 900
	P2.2 Nitrier-, Einsatz- und Vergütungsstähle, legiert	< 1.400
	P3.1 Werkzeug-, Wälzlager-, Feder- und Schnellarbeitsstähle**	< 800
	P3.2 Werkzeug-, Wälzlager-, Feder- und Schnellarbeitsstähle**	< 1.000
	P3.3 Werkzeug-, Wälzlager-, Feder- und Schnellarbeitsstähle**	< 1.500
	P4.1 Rostfreie Stähle, ferritisch und martensitisch	
	P5.1 Stahlguss	
	P6.1 Rostfreier Stahlguss, ferritisch und martensitisch	
M	M1.1 Rostfreie Stähle, austenitisch	< 700
	M1.2 Rostfreie Stähle, ferritisch/austenitisch (Duplex)	< 1.000
	M2.1 Rostfreier Stahlguss, austenitisch	< 700
	M3.1 Rostfreier Stahlguss, ferritisch/austenitisch (Duplex)	< 1.000
K	K1.1 Gusseisen mit Lamellengraphit (Grauguss), GJL	< 300
	K2.1 Gusseisen mit Kugelgraphit, GJS	< 500
	K2.2 Gusseisen mit Kugelgraphit, GJS	≤ 800
	K2.3 Gusseisen mit Kugelgraphit, GJS	> 800
	K3.1 Gusseisen mit Vermiculargraphit, GJV; Temperguss, GJM	< 500
	K3.2 Gusseisen mit Vermiculargraphit, GJV; Temperguss, GJM	> 500

## MEGA-180°-Drill | M9183, M9185

MZG*	Werkstoff	Festigkeit/Härte [N/mm <sup>2</sup> ] [HRC]	
P	P1.1 Bau-, Automaten-, Einsatz- und Vergütungsstähle, unlegiert	< 700	
	P1.2 Bau-, Automaten-, Einsatz- und Vergütungsstähle, unlegiert	< 1.200	
	P2.1 Nitrier-, Einsatz- und Vergütungsstähle, legiert	< 900	
	P2.2 Nitrier-, Einsatz- und Vergütungsstähle, legiert	< 1.400	
	P3.1 Werkzeug-, Wälzlager-, Feder- und Schnellarbeitsstähle**	< 800	
	P3.2 Werkzeug-, Wälzlager-, Feder- und Schnellarbeitsstähle**	< 1.000	
	P3.3 Werkzeug-, Wälzlager-, Feder- und Schnellarbeitsstähle**	< 1.500	
	P5.1 Stahlguss		
	K	K1.1 Gusseisen mit Lamellengraphit (Grauguss), GJL	< 300
		K2.1 Gusseisen mit Kugelgraphit, GJS	< 500
K2.2 Gusseisen mit Kugelgraphit, GJS		≤ 800	
K2.3 Gusseisen mit Kugelgraphit, GJS		> 800	
K3.1 Gusseisen mit Vermiculargraphit, GJV; Temperguss, GJM		< 500	
K3.2 Gusseisen mit Vermiculargraphit, GJV; Temperguss, GJM		> 500	

\* MILLER Zerspanungsgruppen

\*\* Wenn die Legierungsbestandteile Cr, Mo, Ni, V, W in Summe > 8 %, dann die nächst höhere MILLER Zerspanungsgruppe wählen.

	Schnittgeschwindigkeit $v_c$ [m/min]				Vorschub $f$ [mm] bei Bohrerdurchmesser					
	Innenkühlung	Außenkühlung	MMS	Luft	3,00	4,50	6,50	9,50	14,00	20,00
	<b>170</b>	<b>155</b>	<b>155</b>		0,13	0,17	0,22	0,29	0,36	0,43
	<b>155</b>	<b>130</b>	<b>130</b>		0,16	0,21	0,28	0,36	0,45	0,54
	<b>170</b>	<b>145</b>	<b>145</b>		0,15	0,20	0,26	0,34	0,43	0,51
	<b>120</b>	<b>100</b>	<b>100</b>		0,13	0,17	0,21	0,27	0,34	0,40
	<b>130</b>	<b>110</b>	<b>110</b>		0,13	0,18	0,23	0,30	0,39	0,46
	<b>100</b>	<b>95</b>	<b>95</b>		0,12	0,15	0,20	0,25	0,32	0,37
	<b>100</b>	<b>75</b>	<b>85</b>		0,10	0,12	0,16	0,20	0,25	0,29
	<b>100</b>	<b>75</b>	<b>85</b>		0,09	0,12	0,16	0,20	0,25	0,30
	<b>170</b>	<b>145</b>	<b>145</b>		0,15	0,20	0,26	0,34	0,43	0,51
	<b>100</b>	<b>75</b>	<b>85</b>		0,09	0,12	0,16	0,20	0,25	0,30
	<b>65</b>	<b>40</b>	<b>40</b>		0,07	0,09	0,12	0,15	0,19	0,23
	<b>60</b>	<b>35</b>	<b>35</b>		0,06	0,08	0,10	0,13	0,17	0,20
	<b>65</b>	<b>40</b>	<b>40</b>		0,07	0,09	0,12	0,15	0,19	0,23
	<b>60</b>	<b>35</b>	<b>35</b>		0,06	0,08	0,10	0,13	0,17	0,20
	<b>150</b>	<b>105</b>	<b>105</b>	<b>105</b>	0,14	0,21	0,28	0,38	0,49	0,59
	<b>200</b>	<b>125</b>	<b>150</b>	<b>150</b>	0,14	0,20	0,27	0,36	0,46	0,54
	<b>125</b>	<b>95</b>	<b>95</b>		0,13	0,18	0,24	0,31	0,39	0,47
	<b>75</b>	<b>50</b>	<b>65</b>		0,09	0,12	0,15	0,19	0,24	0,28
	<b>115</b>	<b>100</b>	<b>100</b>		0,14	0,19	0,25	0,33	0,42	0,50
	<b>100</b>	<b>90</b>	<b>90</b>		0,12	0,16	0,21	0,27	0,34	0,40

	Schnittgeschwindigkeit $v_c$ [m/min]				Vorschub $f$ [mm] bei Bohrerdurchmesser					
	Innenkühlung	Außenkühlung	MMS	Luft	3,00	4,50	6,50	9,50	14,00	20,00
	<b>80</b>	<b>70</b>	<b>70</b>		0,07	0,09	0,12	0,16	0,20	0,24
	<b>70</b>	<b>60</b>	<b>60</b>		0,09	0,12	0,15	0,20	0,25	0,30
	<b>80</b>	<b>70</b>	<b>70</b>		0,08	0,11	0,14	0,19	0,24	0,28
	<b>55</b>	<b>50</b>	<b>50</b>		0,07	0,09	0,12	0,15	0,19	0,22
	<b>60</b>	<b>50</b>	<b>50</b>		0,07	0,10	0,13	0,17	0,21	0,25
	<b>50</b>	<b>45</b>	<b>45</b>		0,06	0,08	0,11	0,14	0,17	0,21
	<b>50</b>	<b>35</b>	<b>40</b>		0,05	0,07	0,09	0,11	0,14	0,16
	<b>80</b>	<b>70</b>	<b>70</b>		0,08	0,11	0,14	0,19	0,24	0,28
	<b>95</b>	<b>70</b>	<b>70</b>	<b>70</b>	0,09	0,14	0,19	0,25	0,33	0,39
	<b>130</b>	<b>80</b>	<b>95</b>	<b>95</b>	0,10	0,13	0,18	0,24	0,30	0,36
	<b>80</b>	<b>60</b>	<b>60</b>		0,09	0,12	0,16	0,21	0,26	0,31
	<b>50</b>	<b>30</b>	<b>40</b>		0,06	0,08	0,11	0,14	0,17	0,21
	<b>70</b>	<b>65</b>	<b>65</b>		0,09	0,13	0,17	0,22	0,28	0,33
	<b>65</b>	<b>55</b>	<b>55</b>		0,08	0,11	0,14	0,18	0,22	0,26

Die angegebenen Schnittwerte sind Richtwerte.

Die für den jeweiligen Bearbeitungsfall optimalen Daten sollten im Versuch oder während der Bearbeitung ermittelt werden.

# Schnittwertempfehlung für Vollhartmetallbohrer

Vorschub und Schnittgeschwindigkeit

## ECU-Drill-Steel | M6103, M6003, M6105, M6005, M6108, M6112

MZG*	Werkstoff	Festigkeit/Härte [N/mm <sup>2</sup> ] [HRC]	
P	P1.1 Bau-, Automaten-, Einsatz- und Vergütungsstähle, unlegiert	< 700	
	P1.2 Bau-, Automaten-, Einsatz- und Vergütungsstähle, unlegiert	< 1.200	
	P2.1 Nitrier-, Einsatz- und Vergütungsstähle, legiert	< 900	
	P2.2 Nitrier-, Einsatz- und Vergütungsstähle, legiert	< 1.400	
	P3.1 Werkzeug-, Wälzlager-, Feder- und Schnellarbeitsstähle**	< 800	
	P3.2 Werkzeug-, Wälzlager-, Feder- und Schnellarbeitsstähle**	< 1.000	
	P3.3 Werkzeug-, Wälzlager-, Feder- und Schnellarbeitsstähle**	< 1.500	
	P4.1 Rostfreie Stähle, ferritisch und martensitisch		
	P5.1 Stahlguss		
	P6.1 Rostfreier Stahlguss, ferritisch und martensitisch		
	K	K1.1 Gusseisen mit Lamellengraphit (Grauguss), GJL	< 300
		K2.1 Gusseisen mit Kugelgraphit, GJS	< 500
K2.2 Gusseisen mit Kugelgraphit, GJS		≤ 800	
K2.3 Gusseisen mit Kugelgraphit, GJS		> 800	
K3.1 Gusseisen mit Vermiculargraphit, GJV; Temperguss, GJM		< 500	
K3.2 Gusseisen mit Vermiculargraphit, GJV; Temperguss, GJM		> 500	

## MEGA-Drill-Inox | M1703, M1803, M1705, M1805, M1808

MZG*	Werkstoff	Festigkeit/Härte [N/mm <sup>2</sup> ] [HRC]	
P	P1.1 Bau-, Automaten-, Einsatz- und Vergütungsstähle, unlegiert	< 700	
	P1.2 Bau-, Automaten-, Einsatz- und Vergütungsstähle, unlegiert	< 1.200	
	P2.1 Nitrier-, Einsatz- und Vergütungsstähle, legiert	< 900	
	P2.2 Nitrier-, Einsatz- und Vergütungsstähle, legiert	< 1.400	
	P3.1 Werkzeug-, Wälzlager-, Feder- und Schnellarbeitsstähle**	< 800	
	P3.2 Werkzeug-, Wälzlager-, Feder- und Schnellarbeitsstähle**	< 1.000	
	P3.3 Werkzeug-, Wälzlager-, Feder- und Schnellarbeitsstähle**	< 1.500	
	P4.1 Rostfreie Stähle, ferritisch und martensitisch		
	P5.1 Stahlguss		
	P6.1 Rostfreier Stahlguss, ferritisch und martensitisch		
	M	M1.1 Rostfreie Stähle, austenitisch	< 700
		M1.2 Rostfreie Stähle, ferritisch/austenitisch (Duplex)	< 1.000
M2.1 Rostfreier Stahlguss, austenitisch		< 700	
M3.1 Rostfreier Stahlguss, ferritisch/austenitisch (Duplex)		< 1.000	
K	K1.1 Gusseisen mit Lamellengraphit (Grauguss), GJL	< 300	
	K2.1 Gusseisen mit Kugelgraphit, GJS	< 500	
	K2.2 Gusseisen mit Kugelgraphit, GJS	≤ 800	
	K2.3 Gusseisen mit Kugelgraphit, GJS	> 800	
	K3.1 Gusseisen mit Vermiculargraphit, GJV; Temperguss, GJM	< 500	
	K3.2 Gusseisen mit Vermiculargraphit, GJV; Temperguss, GJM	> 500	
N	N2.1 Kupfer, unlegiert und niedriglegiert	< 300	
	N2.2 Kupfer, legiert	> 300	
	N2.3 Messing, Bronze, Rotguss	< 1.200	

\* MILLER Zerspanungsgruppen

\*\* Wenn die Legierungsbestandteile Cr, Mo, Ni, V, W in Summe > 8 %, dann die nächst höhere MILLER Zerspanungsgruppe wählen.

	Schnittgeschwindigkeit $v_c$ [m/min]				Vorschub $f$ [mm] bei Bohrerdurchmesser					
	Innenkühlung	Außenkühlung	MMS	Luft	1,00	1,82	3,31	6,03	10,99	20,00
	<b>75</b>	<b>70</b>	<b>70</b>		0,04	0,06	0,08	0,13	0,20	0,27
	<b>70</b>	<b>55</b>	<b>55</b>		0,05	0,07	0,11	0,16	0,24	0,33
	<b>75</b>	<b>65</b>	<b>65</b>		0,05	0,07	0,10	0,15	0,23	0,31
	<b>55</b>	<b>45</b>	<b>45</b>		0,05	0,06	0,09	0,13	0,18	0,25
	<b>55</b>	<b>50</b>	<b>50</b>		0,04	0,06	0,09	0,14	0,21	0,28
	<b>45</b>	<b>40</b>	<b>40</b>		0,04	0,05	0,08	0,12	0,17	0,23
	<b>45</b>	<b>35</b>	<b>40</b>		0,04	0,05	0,06	0,09	0,13	0,18
	<b>45</b>	<b>35</b>	<b>40</b>		0,03	0,04	0,06	0,09	0,14	0,19
	<b>75</b>	<b>65</b>	<b>65</b>		0,05	0,07	0,10	0,15	0,23	0,31
	<b>45</b>	<b>35</b>	<b>40</b>		0,03	0,04	0,06	0,09	0,14	0,19
	<b>80</b>	<b>60</b>	<b>60</b>	<b>60</b>	0,04	0,07	0,12	0,20	0,32	0,44
	<b>110</b>	<b>70</b>	<b>80</b>	<b>80</b>	0,05	0,07	0,12	0,19	0,30	0,41
	<b>70</b>	<b>50</b>	<b>50</b>		0,04	0,07	0,11	0,17	0,26	0,35
	<b>40</b>	<b>25</b>	<b>35</b>		0,04	0,05	0,08	0,12	0,17	0,23
	<b>60</b>	<b>55</b>	<b>55</b>		0,05	0,07	0,11	0,18	0,27	0,38
	<b>55</b>	<b>50</b>	<b>50</b>		0,05	0,07	0,10	0,15	0,22	0,30
					3,00	4,50	6,50	9,50	14,00	20,00
	<b>100</b>	<b>90</b>	<b>90</b>		0,07	0,09	0,12	0,16	0,20	0,24
	<b>90</b>	<b>75</b>	<b>75</b>		0,09	0,12	0,15	0,20	0,25	0,30
	<b>100</b>	<b>85</b>	<b>85</b>		0,08	0,11	0,14	0,19	0,24	0,28
	<b>70</b>	<b>60</b>	<b>60</b>		0,07	0,09	0,12	0,15	0,19	0,22
	<b>75</b>	<b>65</b>	<b>65</b>		0,07	0,10	0,13	0,17	0,21	0,25
	<b>60</b>	<b>55</b>	<b>55</b>		0,06	0,08	0,11	0,14	0,17	0,21
	<b>60</b>	<b>45</b>	<b>50</b>		0,05	0,07	0,09	0,11	0,14	0,16
	<b>60</b>	<b>45</b>	<b>50</b>		0,05	0,07	0,09	0,11	0,14	0,17
	<b>100</b>	<b>85</b>	<b>85</b>		0,08	0,11	0,14	0,19	0,24	0,28
<b>60</b>	<b>45</b>	<b>50</b>		0,05	0,07	0,09	0,11	0,14	0,17	
	<b>55</b>	<b>35</b>	<b>35</b>		0,06	0,08	0,11	0,14	0,18	0,21
	<b>50</b>	<b>30</b>	<b>30</b>		0,05	0,07	0,09	0,12	0,15	0,18
	<b>55</b>	<b>35</b>	<b>35</b>		0,06	0,08	0,11	0,14	0,18	0,21
	<b>50</b>	<b>30</b>	<b>30</b>		0,05	0,07	0,09	0,12	0,15	0,18
	<b>120</b>	<b>85</b>	<b>85</b>	<b>85</b>	0,12	0,17	0,24	0,32	0,41	0,49
<b>160</b>	<b>100</b>	<b>120</b>	<b>120</b>	0,12	0,17	0,22	0,30	0,38	0,45	
<b>100</b>	<b>75</b>	<b>75</b>		0,11	0,15	0,20	0,26	0,33	0,39	
<b>60</b>	<b>40</b>	<b>50</b>		0,08	0,10	0,13	0,17	0,22	0,26	
<b>90</b>	<b>80</b>	<b>80</b>		0,12	0,16	0,21	0,28	0,35	0,42	
<b>80</b>	<b>70</b>	<b>70</b>		0,10	0,13	0,17	0,22	0,28	0,33	
	<b>140</b>	<b>100</b>			0,09	0,12	0,15	0,20	0,25	0,30
	<b>120</b>	<b>90</b>			0,11	0,15	0,20	0,26	0,33	0,39
	<b>200</b>	<b>160</b>	<b>160</b>	<b>120</b>	0,12	0,17	0,24	0,32	0,41	0,49

Die angegebenen Schnittwerte sind Richtwerte.  
Die für den jeweiligen Bearbeitungsfall optimalen Daten sollten im Versuch oder während der Bearbeitung ermittelt werden.

# Schnittwertempfehlung für Vollhartmetallbohrer

Vorschub und Schnittgeschwindigkeit

## MEGA-Speed-Drill-Inox | M9405, M9408, M9412

MZG*	Werkstoff	Festigkeit/Härte [N/mm <sup>2</sup> ] [HRC]
P	P1.1 Bau-, Automaten-, Einsatz- und Vergütungsstähle, unlegiert	< 700
	P1.2 Bau-, Automaten-, Einsatz- und Vergütungsstähle, unlegiert	< 1.200
	P2.1 Nitrier-, Einsatz- und Vergütungsstähle, legiert	< 900
	P2.2 Nitrier-, Einsatz- und Vergütungsstähle, legiert	< 1.400
	P3.1 Werkzeug-, Wälzlager-, Feder- und Schnellarbeitsstähle**	< 800
	P3.2 Werkzeug-, Wälzlager-, Feder- und Schnellarbeitsstähle**	< 1.000
	P3.3 Werkzeug-, Wälzlager-, Feder- und Schnellarbeitsstähle**	< 1.500
	P4.1 Rostfreie Stähle, ferritisch und martensitisch	
	P5.1 Stahlguss	
	P6.1 Rostfreier Stahlguss, ferritisch und martensitisch	
M	M1.1 Rostfreie Stähle, austenitisch	< 700
	M1.2 Rostfreie Stähle, ferritisch/austenitisch (Duplex)	< 1.000
	M2.1 Rostfreier Stahlguss, austenitisch	< 700
	M3.1 Rostfreier Stahlguss, ferritisch/austenitisch (Duplex)	< 1.000
S	S1.1 Titan, Titanlegierungen	< 400
	S2.1 Titan, Titanlegierungen	< 1.200
	S2.2 Titan, Titanlegierungen	> 1.200
	S3.1 Nickel, unlegiert und legiert	< 900
	S3.2 Nickel, unlegiert und legiert	> 900
	S4.1 Hochwarmfeste Superlegierung, Ni-, Co-, und Fe-basiert	
	S5.1 Wolfram- und Molybdänlegierungen	

## MEGA-Speed-Drill-Iron | M9505

MZG*	Werkstoff	Festigkeit/Härte [N/mm <sup>2</sup> ] [HRC]
K	K1.1 Gusseisen mit Lamellengraphit (Grauguss), GJL	< 300
	K2.1 Gusseisen mit Kugelgraphit, GJS	< 500
	K2.2 Gusseisen mit Kugelgraphit, GJS	≤ 800
	K2.3 Gusseisen mit Kugelgraphit, GJS	> 800
	K3.1 Gusseisen mit Vermiculargraphit, GJV; Temperguss, GJM	< 500
	K3.2 Gusseisen mit Vermiculargraphit, GJV; Temperguss, GJM	> 500

## MEGA-Speed-Drill-Titan | M9605

MZG*	Werkstoff	Festigkeit/Härte [N/mm <sup>2</sup> ] [HRC]
S	S1.1 Titan, Titanlegierungen	< 400
	S2.1 Titan, Titanlegierungen	< 1.200
	S2.2 Titan, Titanlegierungen	> 1.200

\* MILLER Zerspanungsgruppen

\*\* Wenn die Legierungsbestandteile Cr, Mo, Ni, V, W in Summe > 8 %, dann die nächst höhere MILLER Zerspanungsgruppe wählen.

	Schnittgeschwindigkeit $v_c$ [m/min]				Vorschub $f$ [mm] bei Bohrerdurchmesser					
	Innenkühlung	Außenkühlung	MMS	Luft	3,00	4,50	6,50	9,50	14,00	20,00
	<b>150</b>	<b>135</b>	<b>135</b>		0,09	0,12	0,15	0,20	0,25	0,30
	<b>135</b>	<b>115</b>	<b>115</b>		0,11	0,15	0,19	0,25	0,31	0,37
	<b>150</b>	<b>130</b>	<b>130</b>		0,10	0,14	0,18	0,23	0,30	0,35
	<b>105</b>	<b>90</b>	<b>90</b>		0,09	0,12	0,15	0,19	0,24	0,28
	<b>115</b>	<b>100</b>	<b>100</b>		0,09	0,12	0,16	0,21	0,27	0,32
	<b>90</b>	<b>85</b>	<b>85</b>		0,08	0,10	0,13	0,17	0,22	0,26
	<b>90</b>	<b>70</b>	<b>75</b>		0,07	0,09	0,11	0,14	0,17	0,20
	<b>70</b>	<b>55</b>	<b>60</b>		0,06	0,08	0,11	0,14	0,18	0,21
	<b>150</b>	<b>130</b>	<b>130</b>		0,10	0,14	0,18	0,23	0,30	0,35
	<b>70</b>	<b>55</b>	<b>60</b>		0,06	0,08	0,11	0,14	0,18	0,21
	<b>80</b>	<b>50</b>	<b>50</b>		0,08	0,10	0,13	0,17	0,22	0,26
	<b>75</b>	<b>45</b>	<b>45</b>		0,07	0,09	0,11	0,15	0,19	0,22
	<b>80</b>	<b>50</b>	<b>50</b>		0,08	0,10	0,13	0,17	0,22	0,26
	<b>75</b>	<b>45</b>	<b>45</b>		0,07	0,09	0,11	0,15	0,19	0,22
					0,07	0,10	0,13	0,17	0,21	0,25
	<b>35</b>	<b>25</b>			0,06	0,08	0,11	0,14	0,18	0,21
	<b>30</b>	<b>20</b>			0,05	0,07	0,09	0,12	0,15	0,18
	<b>25</b>	<b>20</b>			0,04	0,06	0,07	0,10	0,12	0,14
	<b>20</b>	<b>10</b>			0,05	0,07	0,09	0,12	0,15	0,18
	<b>20</b>	<b>10</b>			0,04	0,06	0,07	0,10	0,12	0,14
	<b>20</b>	<b>10</b>			0,04	0,06	0,07	0,10	0,12	0,14

	Schnittgeschwindigkeit $v_c$ [m/min]				Vorschub $f$ [mm] bei Bohrerdurchmesser					
	Innenkühlung	Außenkühlung	MMS	Luft	3,00	4,50	6,50	9,50	14,00	20,00
	<b>170</b>	<b>120</b>	<b>120</b>	<b>120</b>	0,15	0,21	0,29	0,40	0,51	0,61
	<b>225</b>	<b>140</b>	<b>170</b>	<b>170</b>	0,15	0,21	0,28	0,37	0,48	0,57
	<b>140</b>	<b>105</b>	<b>105</b>		0,14	0,19	0,25	0,32	0,41	0,49
	<b>85</b>	<b>55</b>	<b>70</b>		0,10	0,13	0,17	0,22	0,27	0,32
	<b>125</b>	<b>110</b>	<b>110</b>		0,15	0,20	0,26	0,35	0,44	0,52
	<b>110</b>	<b>100</b>	<b>100</b>		0,13	0,17	0,22	0,28	0,35	0,41

	Schnittgeschwindigkeit $v_c$ [m/min]				Vorschub $f$ [mm] bei Bohrerdurchmesser					
	Innenkühlung	Außenkühlung	MMS	Luft	3,00	4,50	6,50	9,50	14,00	20,00
	<b>40</b>	<b>25</b>			0,077	0,103	0,134	0,173	0,219	0,259
	<b>30</b>	<b>20</b>			0,066	0,088	0,115	0,149	0,188	0,222
	<b>25</b>	<b>15</b>			0,055	0,073	0,095	0,124	0,157	0,185

Die angegebenen Schnittwerte sind Richtwerte.

Die für den jeweiligen Bearbeitungsfall optimalen Daten sollten im Versuch oder während der Bearbeitung ermittelt werden.

# Schnittwertempfehlung für Vollhartmetallbohrer

Vorschub und Schnittgeschwindigkeit

## Tritan-Drill-Alu | M9835

MZG*	Werkstoff	Festigkeit/Härte [N/mm <sup>2</sup> ] [HRC]
N	N1 Aluminium, unlegiert und legiert < 3 % Si	
	N2 Kupfer, unlegiert und niedriglegiert	< 300
		> 300
		< 1.200

## MEGA-Drill-Alu | M2803, M2805, M2808, M2812

MZG*	Werkstoff	Festigkeit/Härte [N/mm <sup>2</sup> ] [HRC]
N	N1 Aluminium, unlegiert und legiert < 3 % Si	
	N2 Kupfer, unlegiert und niedriglegiert	< 300
		> 300
		< 1.200

## MEGA-Drill-Composite-MD | M1985, M2925

MZG*	Werkstoff	Festigkeit/Härte [N/mm <sup>2</sup> ] [HRC]
N	N3.1 Graphit, > 8 µm	
	N3.2 Graphit, ≤ 8 µm	
C	C1 Kunststoffmatrix, Aramidfaserverstärkt (AFK)	
	C2 Kohlenstoffmatrix, Kohlenstofffaserverstärkt (CFC)	
	C3 Metallmatrix (MMC)	
C4	C4.1 Sandwichkonstruktion, Wabenkern (Honeycomb)	
	C4.2 Sandwichkonstruktion, Schaumkern	



	Schnittgeschwindigkeit $v_c$ [m/min]				Vorschub $f$ [mm] bei Bohrerdurchmesser					
	Innenkühlung	Außenkühlung	MMS	Luft	4,00	5,50	7,50	10,50	14,50	20,00
	<b>300</b>	<b>200</b>	<b>250</b>		0,42	0,53	0,66	0,82	1,00	1,15
	<b>250</b>	<b>180</b>	<b>200</b>		0,53	0,68	0,85	1,07	1,31	1,52
	<b>220</b>	<b>150</b>	<b>180</b>		0,53	0,68	0,85	1,07	1,31	1,52
	<b>180</b>	<b>120</b>	<b>150</b>		0,53	0,68	0,85	1,07	1,31	1,52
	<b>140</b>	<b>100</b>			0,42	0,53	0,66	0,82	1,00	1,15
	<b>120</b>	<b>90</b>			0,53	0,68	0,85	1,07	1,31	1,52
	<b>200</b>	<b>160</b>	<b>160</b>	<b>120</b>	0,46	0,61	0,79	1,02	1,26	1,48

	Schnittgeschwindigkeit $v_c$ [m/min]				Vorschub $f$ [mm] bei Bohrerdurchmesser					
	Innenkühlung	Außenkühlung	MMS	Luft	3,00	4,50	6,50	9,50	14,00	20,00
	<b>300</b>	<b>200</b>	<b>250</b>		0,09	0,12	0,15	0,20	0,25	0,30
	<b>250</b>	<b>180</b>	<b>200</b>		0,11	0,15	0,20	0,26	0,33	0,39
	<b>220</b>	<b>150</b>	<b>180</b>		0,11	0,15	0,20	0,26	0,33	0,39
	<b>180</b>	<b>120</b>	<b>150</b>		0,11	0,15	0,20	0,26	0,33	0,39
	<b>140</b>	<b>100</b>			0,09	0,12	0,15	0,20	0,25	0,30
	<b>120</b>	<b>90</b>			0,11	0,15	0,20	0,26	0,33	0,39
	<b>200</b>	<b>160</b>	<b>160</b>	<b>120</b>	0,09	0,14	0,19	0,25	0,33	0,39

	Schnittgeschwindigkeit $v_c$ [m/min]				Vorschub $f$ [mm] bei Bohrerdurchmesser					
	Innenkühlung	Außenkühlung	MMS	Luft	3,00	4,00	5,50	7,50	10,00	12,00
				<b>200</b>	0,07	0,09	0,11	0,14	0,16	0,18
				<b>200</b>	0,07	0,09	0,11	0,14	0,16	0,18
				<b>90</b>	0,04	0,04	0,05	0,06	0,07	0,08
				<b>75</b>	0,04	0,04	0,05	0,06	0,07	0,08
				<b>75</b>	0,04	0,04	0,05	0,06	0,07	0,08
				<b>400</b>	0,04	0,04	0,05	0,06	0,07	0,08
				<b>400</b>	0,04	0,04	0,05	0,06	0,07	0,08

Die angegebenen Schnittwerte sind Richtwerte.

Die für den jeweiligen Bearbeitungsfall optimalen Daten sollten im Versuch oder während der Bearbeitung ermittelt werden.

# Schnittwertempfehlung für Vollhartmetallbohrer

Vorschub und Schnittgeschwindigkeit

## MEGA-Drill-Composite-UDX | M2915, M2935

MZG*	Werkstoff	Festigkeit/Härte [N/mm <sup>2</sup> ] [HRC]
C	C1.1 Kunststoffmatrix, Aramidfaserverstärkt (AFK)	
	C1.2 Kunststoffmatrix (duroplastisch), CFK/GFK	
	C1.3 Kunststoffmatrix (thermoplastisch), CFK/GFK	
	C2.1 Kohlenstoffmatrix, Kohlenstofffaserverstärkt (CFC)	

## MEGA-Drill-Aramid | M2993

MZG*	Werkstoff	Festigkeit/Härte [N/mm <sup>2</sup> ] [HRC]
N	N4.1 Kunststoff, Thermoplaste	
	N4.2 Kunststoff, Duroplaste	
	N4.3 Kunststoff, Schaumstoffe	
C	C1.1 Kunststoffmatrix, Aramidfaserverstärkt (AFK)	
	C1.2 Kunststoffmatrix (duroplastisch), CFK/GFK	
	C1.3 Kunststoffmatrix (thermoplastisch), CFK/GFK	
	C4.1 Sandwichkonstruktion, Wabenkern (Honeycomb)	
	C4.2 Sandwichkonstruktion, Schaumkern	

## MEGA-180°-Drill-Alu | M9883, M9885

MZG*	Werkstoff	Festigkeit/Härte [N/mm <sup>2</sup> ] [HRC]	
N	N1	N1.1 Aluminium, unlegiert und legiert < 3 % Si	
		N1.2 Aluminium, legiert ≤ 7 % Si	
		N1.3 Aluminium, legiert > 7-12 % Si	
		N1.4 Aluminium, legiert > 12 % Si	
	N2	N2.1 Kupfer, unlegiert und niedriglegiert	< 300
		N2.2 Kupfer, legiert	> 300
		N2.3 Messing, Bronze, Rotguss	< 1.200

	Schnittgeschwindigkeit $v_c$ [m/min]				Vorschub $f$ [mm] bei Bohrerdurchmesser					
	Innenkühlung	Außenkühlung	MMS	Luft	3,00	4,00	5,50	7,50	10,00	12,00
				<b>90</b>	0,04	0,04	0,05	0,06	0,07	0,08
				<b>75</b>	0,04	0,04	0,05	0,06	0,07	0,08
				<b>75</b>	0,04	0,04	0,05	0,06	0,07	0,08

	Schnittgeschwindigkeit $v_c$ [m/min]				Vorschub $f$ [mm] bei Bohrerdurchmesser					
	Innenkühlung	Außenkühlung	MMS	Luft	2,50	3,40	4,70	6,40	8,80	12,00
		<b>90</b>			0,04	0,05	0,08	0,1	0,14	0,2
		<b>100</b>			0,05	0,06	0,09	0,11	0,15	0,21
				<b>200</b>	0,06	0,08	0,09	0,12	0,14	0,16
				<b>100</b>	0,04	0,04	0,05	0,06	0,07	0,08
				<b>150</b>	0,04	0,04	0,05	0,06	0,07	0,08
				<b>150</b>	0,04	0,04	0,05	0,06	0,07	0,08

	Schnittgeschwindigkeit $v_c$ [m/min]				Vorschub $f$ [mm] bei Bohrerdurchmesser					
	Innenkühlung	Außenkühlung	MMS	Luft	3,00	4,50	6,50	9,50	14,00	20,00
	<b>240</b>	<b>160</b>	<b>200</b>		0,07	0,09	0,12	0,16	0,20	0,24
	<b>200</b>	<b>145</b>	<b>160</b>		0,09	0,12	0,16	0,21	0,26	0,31
	<b>175</b>	<b>120</b>	<b>145</b>		0,09	0,12	0,16	0,21	0,26	0,31
	<b>145</b>	<b>95</b>	<b>120</b>		0,09	0,12	0,16	0,21	0,26	0,31
	<b>110</b>	<b>80</b>			0,07	0,09	0,12	0,16	0,20	0,24
	<b>95</b>	<b>70</b>			0,09	0,12	0,16	0,21	0,26	0,31
	<b>160</b>	<b>130</b>	<b>130</b>	<b>95</b>	0,09	0,14	0,19	0,25	0,33	0,39

Die angegebenen Schnittwerte sind Richtwerte.

Die für den jeweiligen Bearbeitungsfall optimalen Daten sollten im Versuch oder während der Bearbeitung ermittelt werden.

# Schnittwertempfehlung für Vollhartmetallbohrer

Vorschub und Schnittgeschwindigkeit

## ECU-G-Drill | M2605, M2608

MZG*	Werkstoff	Festigkeit/Härte [N/mm <sup>2</sup> ] [HRC]	
<b>K</b>	K1.1 Gusseisen mit Lamellengraphit (Grauguss), GJL	< 300	
	K2.1 Gusseisen mit Kugelgraphit, GJS	< 500	
	K2.2 Gusseisen mit Kugelgraphit, GJS	≤ 800	
	K2.3 Gusseisen mit Kugelgraphit, GJS	> 800	
<b>N</b>	N1 Aluminium, unlegiert und legiert < 3 % Si	N1.1 Aluminium, unlegiert und legiert < 3 % Si	
		N1.2 Aluminium, legiert ≤ 7 % Si	
		N1.3 Aluminium, legiert > 7-12 % Si	
		N1.4 Aluminium, legiert > 12 % Si	
	N2 Kupfer, unlegiert und niedriglegiert	N2.1 Kupfer, unlegiert und niedriglegiert	< 300
		N2.2 Kupfer, legiert	> 300
		N2.3 Messing, Bronze, Rotguss	< 1.200

	Schnittgeschwindigkeit $v_c$ [m/min]				Vorschub $f$ [mm] bei Bohrerdurchmesser					
	Innenkühlung	Außenkühlung	MMS	Luft	3,00	4,50	6,50	9,50	14,00	20,00
	<b>90</b>	<b>65</b>	<b>65</b>	<b>65</b>	0,08	0,12	0,16	0,22	0,29	0,34
	<b>120</b>	<b>75</b>	<b>90</b>	<b>90</b>	0,08	0,12	0,16	0,21	0,27	0,32
	<b>75</b>	<b>55</b>	<b>55</b>		0,08	0,10	0,14	0,18	0,23	0,27
	<b>215</b>	<b>155</b>	<b>170</b>		0,08	0,10	0,14	0,18	0,23	0,27
	<b>185</b>	<b>130</b>	<b>155</b>		0,08	0,10	0,14	0,18	0,23	0,27
	<b>155</b>	<b>100</b>	<b>130</b>		0,08	0,10	0,14	0,18	0,23	0,27
	<b>160</b>	<b>130</b>	<b>130</b>	<b>95</b>	0,08	0,12	0,16	0,22	0,29	0,34

Die angegebenen Schnittwerte sind Richtwerte.

Die für den jeweiligen Bearbeitungsfall optimalen Daten sollten im Versuch oder während der Bearbeitung ermittelt werden.



# VOLLBOHREN MIT WECHSELKOPFSYSTEM

## Schneidplattenbohrer EXD

Technologie	200
Typ 01 - Steel	202
Typ 05 - Steel-Pyramid	204
Typ 10 - Uni, Form EK	206
Typ 02 - Inox	207
Typ 04 - Iron	209
Typ 03 - Alu	210
Schneidplattenhalter EXS	211
Zubehör und Ersatzteile	215
Schnittwertempfehlung	216
Handhabungshinweise für Schneidplattenbohrer EXD	514

## Wechselkopfböhrer TTD

Technologie	220
Typ 01 - Uni-Plus	222
Typ 04 - Steel	223
Typ 02 - Inox	225
Typ 05 - Iron	227
Typ 03 - Alu	228
Wechselkopfhalter TTS	229
Zubehör und Ersatzteile	238
Schnittwertempfehlung	240

## Wechselkopfböhrer TTD-Tritan

Technologie	244
Typ 01 - Uni	246
Wechselkopfhalter TTS-300	247
Zubehör und Ersatzteile	250
Schnittwertempfehlung	252
Anwendungshinweise Wechselkopfböhrer TTD-Tritan	510





# SCHNEIDPLATTENBOHRER EXD

## Stabile Schneidenaufnahme, einfaches Spannsystem

**Mit modernster Fertigungstechnologie im Durchmesserbereich von acht bis 50 mm**

Den Schneidplattenbohrer EXD für den mittleren bis oberen Durchmesserbereich zeichnen eine sehr gute Spanformung und eine sichere Spanabfuhr aus. Zahlreiche Schneidplattenwechsel pro Halter sind möglich, da der Grundhalter nicht ausgewaschen wird. Besonders einfach und zugleich effektiv ist auch das Spannsystem für die Schneidplatte aufgebaut. Es besteht aus einer Schraube, die quer durch die Schneidplatte geschraubt wird und die Schneidplatte stabil unter Vorspannung in der Prismenaufnahme spannt. Die Schneidplatte wird besonders stabil in der Prismenaufnahme gehalten, was hohe Schnittdaten und Bohrungsqualitäten ermöglicht.

**Additive Fertigung ermöglicht optimale Kühlkanalausführung und Durchmesser ab 9 mm**

Um auch Durchmesser kleiner 13 mm realisieren zu können wird die additive Fertigung eingesetzt. Dieses Verfahren ermöglicht es, Grundkörper im Durchmesserbereich von acht bis 13 mm mit gewendelten Kühlkanälen herzustellen. So erreicht der EXD mit gewendelten Kanälen im Vergleich zur zentralen Kühlmittelführung mit Umlenkungen einen um 100 Prozent gesteigerten Kühlmitteldurchfluss, speziell durch die von der Kreisform abweichenden Kühlkanalprofile.



# Werkzeugfeatures im Detail

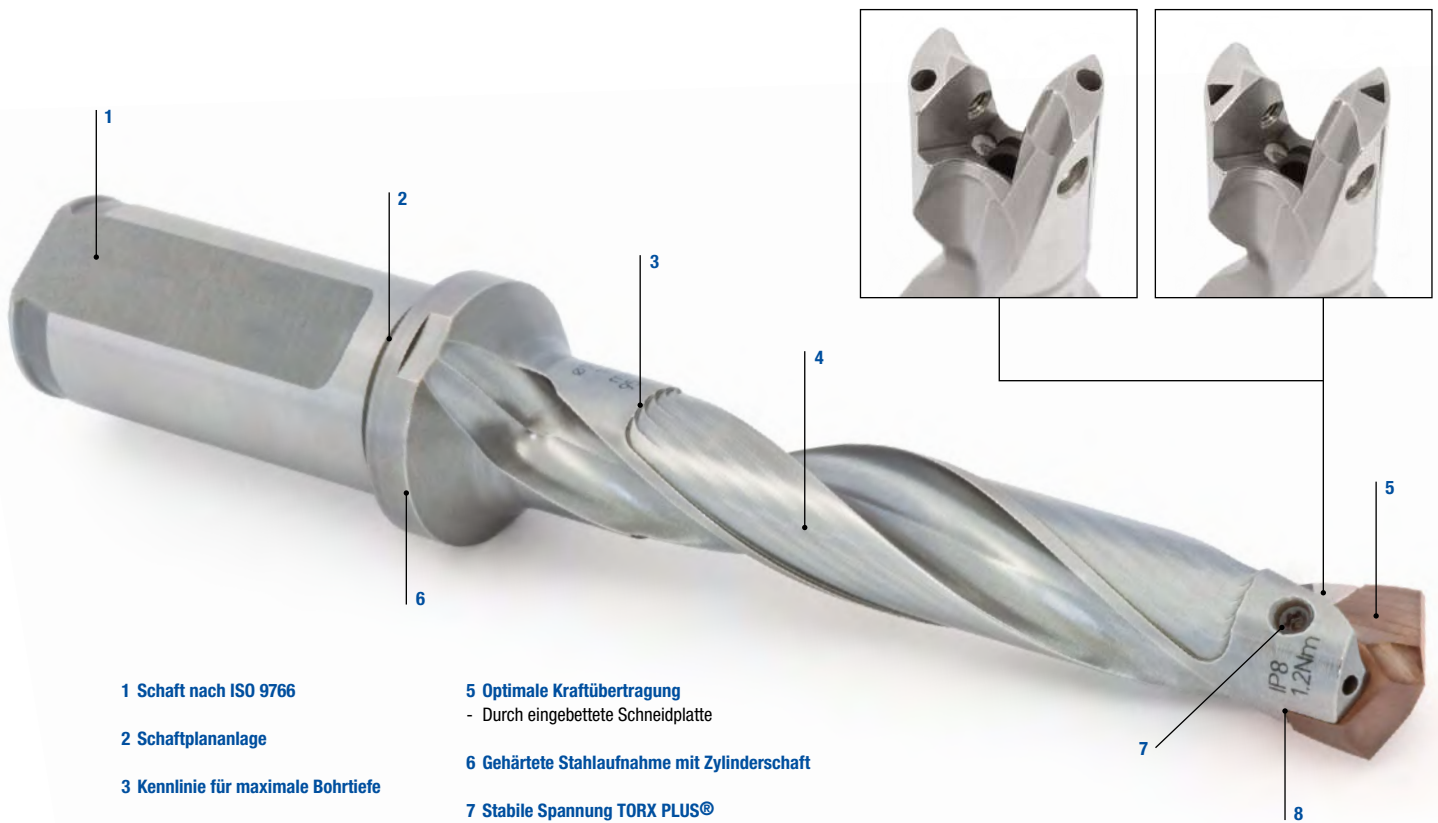

**1 Schaft nach ISO 9766**

**2 Schaftplananlage**

**3 Kennlinie für maximale Bohrtiefe**

**4 Rückenfreilegung**  
- Für optimale Spanabfuhr

**5 Optimale Kraftübertragung**  
- Durch eingebettete Schneidplatte

**6 Gehärtete Stahlaufnahme mit Zylinderschaft**

**7 Stabile Spannung TORX PLUS®**

**8 Prismatischer Plattensitz**  
- Für optimale Zentrierung der Schneidplatte



## AUF EINEN BLICK

- Hohe Lagerverfügbarkeit
- Durchmesserbereich von 9 bis 50 mm
- Halterprogramm 1,5 | 3 | 5 | 8 und 12xD
- Schneidplatten für Stahl, Edelstahl, Aluminium und Guss
- Mit Innenkühlung
- Spezielle Oberflächenbehandlung
- Einfaches Handling, Schneidplattenwechsel in der Maschine

## LEISTUNGSMERKMALE

- Gleiche Performance wie Vollhartmetallbohrer
- Hohe Rundlaufgenauigkeit
- Stabiler Bund zur Aufnahme hoher Axialkräfte
- Sichere Spannung der Schneidplatte durch TORX PLUS®-Schraube
- Robustes System

## VORTEILE

- Kostenoptimiert
- Höchste Performance
- Verwechslungssicherer Schneidplatteneinbau
- Optimale Spanbildung in der Schneidplatte und Spanabfuhr
- Ein Halter für alle Bohrergeometrien
- Viele Schneidplattenwechsel pro Halter möglich, da keine Auswaschung des Grundhalters

# Schneidplatten EXD

Aus Vollhartmetall, innere Kühlmittelzufuhr  
Typ 01 - Steel

## Ausführung:

Bohrerdurchmesser: 9,00 - 50,00 mm  
Bohrungstoleranz:  $\geq$  IT 10  
Beschichtung: HP240  
Schneidenanzahl: 2  
Anzahl Führungsfasen: 2  
Spitzenwinkel: 135°

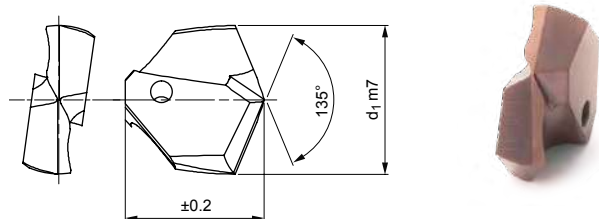

## Lagerhaltige Vorzugsbaureihe

d <sub>1</sub> von 9,00 bis 15,50			
d <sub>1</sub> m7	Haltergröße D	Spezifikation	Bestell-Nr.
9,00	9	EXD-2F01-0900-HP240	30615592
9,50	9,5	EXD-2F01-0950-HP240	30615593
10,00	10	EXD-2F01-1000-HP240	30615595
10,20	10	EXD-2F01-1020-HP240	30645577
10,50	10,5	EXD-2F01-1050-HP240	30615596
10,70	10,5	EXD-2F01-1070-HP240	30615597
11,00	11	EXD-2F01-1100-HP240	30615598
11,50	11,5	EXD-2F01-1150-HP240	30615599
12,00	12	EXD-2F01-1200-HP240	30615601
12,50	12,5	EXD-2F01-1250-HP240	30615602
12,70	12,5	EXD-2F01-1270-HP240	30615603
12,80	12,5	EXD-2F01-1280-HP240	30645596
13,00	13	EXD-2F01-1300-HP240	30509787
13,10	13	EXD-2F01-1310-HP240	30555932
13,30	13	EXD-2F01-1330-HP240	30555934
13,40	13	EXD-2F01-1340-HP240	30555935
13,50	13,5	EXD-2F01-1350-HP240	30509788
13,80	13,5	EXD-2F01-1380-HP240	30555937
13,90	13,5	EXD-2F01-1390-HP240	30555938
14,00	14	EXD-2F01-1400-HP240	30509789
14,10	14	EXD-2F01-1410-HP240	30555939
14,20	14	EXD-2F01-1420-HP240	30555940
14,30	14	EXD-2F01-1430-HP240	30555941
14,50	14,5	EXD-2F01-1450-HP240	30509790
14,60	14,5	EXD-2F01-1460-HP240	30555943
14,70	14,5	EXD-2F01-1470-HP240	30510309
14,80	14,5	EXD-2F01-1480-HP240	30555944
14,90	14,5	EXD-2F01-1490-HP240	30555945
15,00	15	EXD-2F01-1500-HP240	30509792
15,10	15	EXD-2F01-1510-HP240	30555946
15,20	15	EXD-2F01-1520-HP240	30555947
15,25	15	EXD-2F01-1525-HP240	30509793
15,50	15	EXD-2F01-1550-HP240	30509794

d <sub>1</sub> von 15,70 bis 19,50			
d <sub>1</sub> m7	Haltergröße D	Spezifikation	Bestell-Nr.
15,70	15	EXD-2F01-1570-HP240	30510310
15,80	15	EXD-2F01-1580-HP240	30555951
15,90	15	EXD-2F01-1590-HP240	30555952
16,00	16	EXD-2F01-1600-HP240	30509795
16,10	16	EXD-2F01-1610-HP240	30555953
16,20	16	EXD-2F01-1620-HP240	30555954
16,25	16	EXD-2F01-1625-HP240	30509796
16,30	16	EXD-2F01-1630-HP240	30555955
16,40	16	EXD-2F01-1640-HP240	30555956
16,50	16	EXD-2F01-1650-HP240	30509797
16,60	16	EXD-2F01-1660-HP240	30555957
16,70	16	EXD-2F01-1670-HP240	30510311
16,80	16	EXD-2F01-1680-HP240	30555958
16,90	16	EXD-2F01-1690-HP240	30555959
17,00	17	EXD-2F01-1700-HP240	30509799
17,10	17	EXD-2F01-1710-HP240	30555960
17,20	17	EXD-2F01-1720-HP240	30555961
17,30	17	EXD-2F01-1730-HP240	30555962
17,40	17	EXD-2F01-1740-HP240	30555963
17,50	17	EXD-2F01-1750-HP240	30509800
17,60	17	EXD-2F01-1760-HP240	30555964
17,70	17	EXD-2F01-1770-HP240	30510312
17,80	17	EXD-2F01-1780-HP240	30555965
17,90	17	EXD-2F01-1790-HP240	30555966
18,00	18	EXD-2F01-1800-HP240	30509801
18,10	18	EXD-2F01-1810-HP240	30555967
18,50	18	EXD-2F01-1850-HP240	30509803
18,60	18	EXD-2F01-1860-HP240	30555971
18,70	18	EXD-2F01-1870-HP240	30510313
18,80	18	EXD-2F01-1880-HP240	30555972
18,90	18	EXD-2F01-1890-HP240	30555973
19,00	19	EXD-2F01-1900-HP240	30509804
19,50	19	EXD-2F01-1905-HP240	30645601

## Schneidplatten EXD aus Vollhartmetall, innere Kühlmittelzufuhr - Typ 01

d <sub>1</sub> von 19,10 bis 24,70			
d <sub>1</sub> m7	Haltergröße D	Spezifikation	Bestell-Nr.
19,10	19	EXD-2F01-1910-HP240	30555974
19,20	19	EXD-2F01-1920-HP240	30509805
19,25	19	EXD-2F01-1925-HP240	30509807
19,30	19	EXD-2F01-1930-HP240	30555975
19,50	19	EXD-2F01-1950-HP240	30509809
19,60	19	EXD-2F01-1960-HP240	30555976
19,70	19	EXD-2F01-1970-HP240	30510314
19,75	19	EXD-2F01-1975-HP240	30509810
19,80	19	EXD-2F01-1980-HP240	30555977
19,90	19	EXD-2F01-1990-HP240	30555978
20,00	20	EXD-2F01-2000-HP240	30509811
20,40	20	EXD-2F01-2040-HP240	30509812
20,50	20	EXD-2F01-2050-HP240	30509813
20,70	20	EXD-2F01-2070-HP240	30510315
20,75	20	EXD-2F01-2075-HP240	30509814
21,00	21	EXD-2F01-2100-HP240	30509815
21,50	21	EXD-2F01-2150-HP240	30509816
21,70	21	EXD-2F01-2170-HP240	30510316
22,00	22	EXD-2F01-2200-HP240	30509817
22,25	22	EXD-2F01-2225-HP240	30509818
22,50	22	EXD-2F01-2250-HP240	30509819
22,70	22	EXD-2F01-2270-HP240	30510317
22,75	22	EXD-2F01-2275-HP240	30509820
23,00	23	EXD-2F01-2300-HP240	30509821
23,25	23	EXD-2F01-2325-HP240	30509822
23,50	23	EXD-2F01-2350-HP240	30509823
23,75	23	EXD-2F01-2375-HP240	30509824
24,00	24	EXD-2F01-2400-HP240	30509825
24,30	24	EXD-2F01-2430-HP240	30632968
24,50	24	EXD-2F01-2450-HP240	30509826
24,70	24	EXD-2F01-2470-HP240	30510319

d <sub>1</sub> von 24,75 bis 42,00			
d <sub>1</sub> m7	Haltergröße D	Spezifikation	Bestell-Nr.
24,75	24	EXD-2F01-2475-HP240	30509827
24,80	24	EXD-2F01-2480-HP240	30660647
25,00	25	EXD-2F01-2500-HP240	30509828
25,40	25	EXD-2F01-2540-HP240	30509829
25,50	25	EXD-2F01-2550-HP240	30509830
25,70	25	EXD-2F01-2570-HP240	30510320
25,80	25	EXD-2F01-2580-HP240	30579622
26,00	26	EXD-2F01-2600-HP240	30509831
26,50	26	EXD-2F01-2650-HP240	30509832
27,00	27	EXD-2F01-2700-HP240	30509833
27,50	27	EXD-2F01-2750-HP240	30509834
27,75	27	EXD-2F01-2775-HP240	30509835
28,00	28	EXD-2F01-2800-HP240	30509836
28,50	28	EXD-2F01-2850-HP240	30509838
29,00	29	EXD-2F01-2900-HP240	30509839
29,50	29	EXD-2F01-2950-HP240	30509840
29,80	29	EXD-2F01-2980-HP240	30727705
30,00	30	EXD-2F01-3000-HP240	30509841
30,25	30	EXD-2F01-3025-HP240	30509842
30,50	30	EXD-2F01-3050-HP240	30509843
31,00	31	EXD-2F01-3100-HP240	30509845
31,50	31	EXD-2F01-3150-HP240	30509846
32,00	32	EXD-2F01-3200-HP240	30509847
33,00	33	EXD-2F01-3300-HP240	30649621
34,00	34	EXD-2F01-3400-HP240	30649622
35,00	35	EXD-2F01-3500-HP240	30649623
36,00	36	EXD-2F01-3600-HP240	30649624
37,00	37	EXD-2F01-3700-HP240	30649625
38,00	37	EXD-2F01-3800-HP240	30649626
40,00	39	EXD-2F01-4000-HP240	30657110
42,00	41	EXD-2F01-4200-HP240	30657112

## Konfigurierbare Merkmale



**Durchmesser:**  
Durchmesser in Abstufungen  
von 0,01 mm frei wählbar



## Spezifikation:

EXD-2F01-[Durchmesser]-HP240

## Beispiel:

EXD-2F01-0901-HP240

Werkzeugdurchmesser d<sub>1</sub> = 9,01 mm

## Abmessungen konfigurierbare Baureihe

d <sub>1</sub> min.	d <sub>1</sub> max.
9,00	50,00

Maßangaben in mm.

Schnittwertempfehlung siehe Kapitelende.

Sonderausführungen und andere Beschichtungen auf Anfrage.

# Schneidplatten EXD

Aus Vollhartmetall, innere Kühlmittelzufuhr  
Typ 05 - Steel-Pyramid

## Ausführung:

Bohrerdurchmesser:	14,00 - 32,00 mm
Bohrungstoleranz:	≥ IT 10
Beschichtung:	HP605
Schneidenanzahl:	2
Anzahl Führungsfasen:	2
Spitzenwinkel:	160°

## Anwendung:

Für Bearbeitungen mit besonderem Anspruch an die Werkzeug-Zentrierung. (z. B. dünnwandige Bauteile, labile Bearbeitungsverhältnisse).

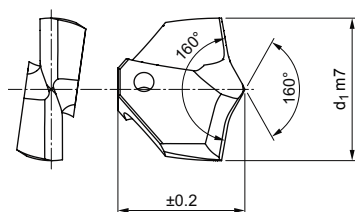

## Lagerhaltige Vorzugsbaureihe

Baumaße		Spezifikation	Bestell-Nr.
d <sub>1</sub> m7	Haltergröße D		
14,00	14	EXD-2F05-1400-HP605	31109942
15,00	15	EXD-2F05-1500-HP605	31109946
16,00	16	EXD-2F05-1600-HP605	31109991
16,50	16	EXD-2F05-1650-HP605	31109994
17,50	17	EXD-2F05-1750-HP605	31109996
18,00	18	EXD-2F05-1800-HP605	31109998
18,50	18	EXD-2F05-1850-HP605	31109999
19,27	19	EXD-2F05-1927-HP605	31207980
19,80	19	EXD-2F05-1980-HP605	31110002
20,00	20	EXD-2F05-2000-HP605	31110003
20,50	20	EXD-2F05-2050-HP605	31110004
21,00	21	EXD-2F05-2100-HP605	31110005
21,50	21	EXD-2F05-2150-HP605	31110006
22,00	22	EXD-2F05-2200-HP605	31110007
23,00	23	EXD-2F05-2300-HP605	31110009
24,00	24	EXD-2F05-2400-HP605	31110010
25,00	25	EXD-2F05-2500-HP605	31110012
26,00	26	EXD-2F05-2600-HP605	31110014
26,50	26	EXD-2F05-2650-HP605	31110015
27,00	27	EXD-2F05-2700-HP605	31110016
28,00	28	EXD-2F05-2800-HP605	31110017
29,00	29	EXD-2F05-2900-HP605	31110018
30,00	30	EXD-2F05-3000-HP605	31110019
32,00	32	EXD-2F05-3200-HP605	31110021

## Konfigurierbare Merkmale



### Durchmesser:

Durchmesser in Abstufungen von 0,01 mm frei wählbar



### Spezifikation:

EXD-2F01-[Durchmesser]-HP240

## Abmessungen konfigurierbare Baureihe

d <sub>1</sub> min.	d <sub>1</sub> max.
14,00	32,00

### Beispiel:

EXD-2F01-1401-HP240

Werkzeugdurchmesser d<sub>1</sub> = 14,01 mm

Maßangaben in mm.

Schnittwertempfehlung siehe Kapitelende.

Sonderausführungen und andere Beschichtungen auf Anfrage.

# Praxistest

## Bearbeitung von Blechen, Wärmetauschern / Kesselblechen, Stahlträgern (T, U, ...).

Speziell für die Bearbeitung mit besonderem Anspruch an die Werkzeugzentrierung sowie für dünnwandige Bauteile und labile Bearbeitungsverhältnisse.



### Bearbeitungsdaten

Werkzeug:  $\varnothing$  18 mm | 5xD  
 Spannfutter: Flächenspannfutter  
 Kühlung: MMS-Innenkühlung

$l_B$  [mm]: 90  
 $v_C$  [m/min]: 63  
 $n$  [ $\text{min}^{-1}$ ]: 1.115  
 $f$  [mm]: 0,3  
 $v_f$  [mm/min]: 334

### Anzahl Bohrungen

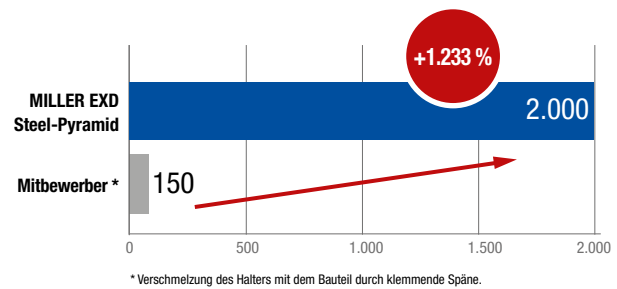

# Schneidplatten EXD

Aus Vollhartmetall,  
Typ 10 - Uni, Form EK

**Ausführung:**

Bohrerdurchmesser: 10,00 - 33,00 mm  
 Bohrungstoleranz: ≥ IT 10  
 Beschichtung: HP240  
 Schneidenanzahl: 2  
 Anzahl Führungsfasen: 2  
 Spitzenwinkel: 142°  
 Besonderheiten: Form EK  
 180° Schneide,  
 Schutzfase 0,5 mm

**Anwendung:**

Für Schrauben-Durchgangsbohrungen nach DIN-ISO 273 und Senkungen nach DIN 74, Blatt 2 Form H, J und K, Ausführung mittel. Für Schrauben nach DIN 912, 6912 und 7984, ISO 1207 (DIN 84).

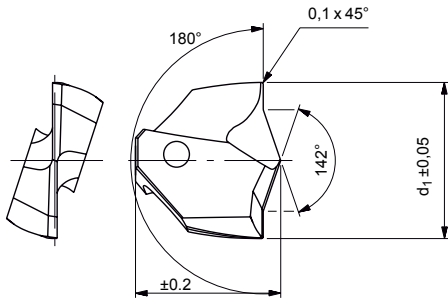

**Lagerhaltige Vorzugsbaureihe**

Baumaße		Für Zylinderkopf-DIN-Schrauben	Passend für Ø Durchgangsbohrung	Spezifikation	Bestell-Nr.
d <sub>1</sub> ± 0,05	Haltergröße D				
10,00	10	M5	5,5	EXD-2F10-1000-HP240	30727290
11,00	11	M6	6,6	EXD-2F10-1100-HP240	30727291
15,00	15	M8	9	EXD-2F10-1500-HP240	30727317
18,00	18	M10	11	EXD-2F10-1800-HP240	30727318
20,00	20	M12	13,5	EXD-2F10-2000-HP240	30714612
24,00	24	M14	15	EXD-2F10-2400-HP240	30727320
26,00	26	M16	17	EXD-2F10-2600-HP240	30727321
30,00	30	M18	19	EXD-2F10-3000-HP240	30727323
33,00	33	M20	21	EXD-2F10-3300-HP240	30727325

**Anwendungshinweis:**

Erstellung einer Schrauben-Durchgangsbohrung mit Flachsenkung für Zylinderkopfschrauben nach DIN (Beispiel M12)

**1. Schritt:**

Senkung mit EXD Typ10, Form EK (Beispiel Durchmesser 20 mm)

**2. Schritt:**

Bohrung mit Vollbohrer (Beispiel Durchmesser 13,5 mm)

**Ergebnis:**

Schrauben-Durchgangsbohrung mit Flachsenkung und Fase für M12 Zylinderkopfschraube

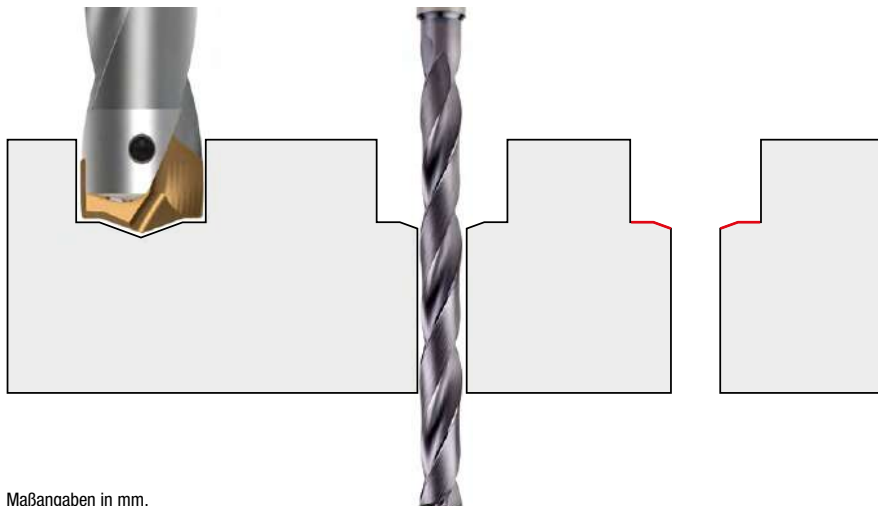

Maßangaben in mm.  
 Schnittwertempfehlung siehe Kapitelende.  
 Sonderausführungen und andere Beschichtungen auf Anfrage.

# Schneidplatten EXD

Aus Vollhartmetall, innere Kühlmittelzufuhr  
Typ 02 - Inox

**Ausführung:**

Bohrerdurchmesser: 9,00 - 50,00 mm  
Bohrungstoleranz: ≥ IT 10  
Beschichtung: HP600  
Schneidenanzahl: 2  
Anzahl Führungsfasen: 2  
Spitzenwinkel: 135°

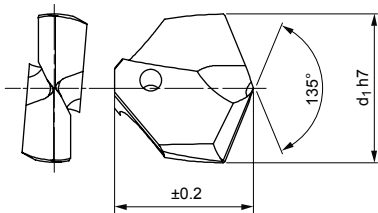

**Lagerhaltige Vorzugsbaureihe**

d <sub>1</sub> von 10,00 bis 16,70			
d <sub>1</sub> h7	Haltergröße D	Spezifikation	Bestell-Nr.
10,00	10	EXD-2F02-1000-HP600	30615609
10,50	10,5	EXD-2F02-1050-HP600	30615610
11,00	11	EXD-2F02-1100-HP600	30615612
12,00	12	EXD-2F02-1200-HP600	30615615
12,50	12,5	EXD-2F02-1250-HP600	30615616
13,00	13	EXD-2F02-1300-HP600	30509849
13,50	13,5	EXD-2F02-1350-HP600	30509850
14,00	14	EXD-2F02-1400-HP600	30509851
14,10	14	EXD-2F02-1410-HP600	30555986
14,20	14	EXD-2F02-1420-HP600	30555987
14,30	14	EXD-2F02-1430-HP600	30555988
14,40	14	EXD-2F02-1440-HP600	30555989
14,50	14,5	EXD-2F02-1450-HP600	30509852
14,60	14,5	EXD-2F02-1460-HP600	30555990
14,70	14,5	EXD-2F02-1470-HP600	30510288
14,75	14,5	EXD-2F02-1475-HP600	30509853
14,80	14,5	EXD-2F02-1480-HP600	30555991
15,00	15	EXD-2F02-1500-HP600	30509854
15,20	15	EXD-2F02-1520-HP600	30555994
15,25	15	EXD-2F02-1525-HP600	30509855
15,40	15	EXD-2F02-1540-HP600	30555996
15,50	15	EXD-2F02-1550-HP600	30509856
15,60	15	EXD-2F02-1560-HP600	30555997
15,70	15	EXD-2F02-1570-HP600	30510289
15,80	15	EXD-2F02-1580-HP600	30555998
16,00	16	EXD-2F02-1600-HP600	30509857
16,10	16	EXD-2F02-1610-HP600	30543427
16,20	16	EXD-2F02-1620-HP600	30556000
16,30	16	EXD-2F02-1630-HP600	30556001
16,40	16	EXD-2F02-1640-HP600	30556002
16,50	16	EXD-2F02-1650-HP600	30509859
16,60	16	EXD-2F02-1660-HP600	30556003
16,70	16	EXD-2F02-1670-HP600	30510290

d <sub>1</sub> von 16,75 bis 23,75			
d <sub>1</sub> h7	Haltergröße D	Spezifikation	Bestell-Nr.
16,75	16	EXD-2F02-1675-HP600	30509860
16,80	16	EXD-2F02-1680-HP600	30556004
16,90	16	EXD-2F02-1690-HP600	30556005
17,00	17	EXD-2F02-1700-HP600	30509861
17,30	17	EXD-2F02-1730-HP600	30556008
17,40	17	EXD-2F02-1740-HP600	30556009
17,50	17	EXD-2F02-1750-HP600	30509862
17,70	17	EXD-2F02-1770-HP600	30510291
17,90	17	EXD-2F02-1790-HP600	30556012
18,00	18	EXD-2F02-1800-HP600	30509863
18,50	18	EXD-2F02-1850-HP600	30509865
18,60	18	EXD-2F02-1860-HP600	30556017
18,70	18	EXD-2F02-1870-HP600	30510292
19,00	19	EXD-2F02-1900-HP600	30509866
19,40	19	EXD-2F02-1940-HP600	30509869
19,50	19	EXD-2F02-1950-HP600	30509870
19,60	19	EXD-2F02-1960-HP600	30556022
19,70	19	EXD-2F02-1970-HP600	30510293
19,75	19	EXD-2F02-1975-HP600	30509871
19,80	19	EXD-2F02-1980-HP600	30556023
19,90	19	EXD-2F02-1990-HP600	30556024
20,00	20	EXD-2F02-2000-HP600	30509872
20,40	20	EXD-2F02-2040-HP600	30509873
20,50	20	EXD-2F02-2050-HP600	30509874
21,00	21	EXD-2F02-2100-HP600	30509876
21,50	21	EXD-2F02-2150-HP600	30509877
21,70	21	EXD-2F02-2170-HP600	30510295
22,00	22	EXD-2F02-2200-HP600	30509878
22,25	22	EXD-2F02-2225-HP600	30509879
22,70	22	EXD-2F02-2270-HP600	30510296
23,00	23	EXD-2F02-2300-HP600	30509882
23,50	23	EXD-2F02-2350-HP600	30509884
23,75	23	EXD-2F02-2375-HP600	30509885

Fortsetzung auf nächster Seite.

## Schneidplatten EXD aus Vollhartmetall, innere Kühlmittelzufuhr - Typ 02

d <sub>1</sub> von 24,00 bis 27,00			
d <sub>1</sub> h7	Haltegröße D	Spezifikation	Bestell-Nr.
24,00	24	EXD-2F02-2400-HP600	30509886
24,40	24	EXD-2F02-2440-HP600	30664627
24,50	24	EXD-2F02-2450-HP600	30509887
24,70	24	EXD-2F02-2470-HP600	30510298
24,75	24	EXD-2F02-2475-HP600	30509888
25,00	25	EXD-2F02-2500-HP600	30509889
25,50	25	EXD-2F02-2550-HP600	30509891
25,70	25	EXD-2F02-2570-HP600	30510299
26,00	26	EXD-2F02-2600-HP600	30509892
26,50	26	EXD-2F02-2650-HP600	30509893
27,00	27	EXD-2F02-2700-HP600	30509894

d <sub>1</sub> von 27,50 bis 40,00			
d <sub>1</sub> h7	Haltegröße D	Spezifikation	Bestell-Nr.
27,50	27	EXD-2F02-2750-HP600	30509895
28,00	28	EXD-2F02-2800-HP600	30509897
29,00	29	EXD-2F02-2900-HP600	30509900
29,50	29	EXD-2F02-2950-HP600	30509901
30,00	30	EXD-2F02-3000-HP600	30509902
30,75	30	EXD-2F02-3075-HP600	30509905
33,00	33	EXD-2F02-3300-HP600	30649627
36,00	36	EXD-2F02-3600-HP600	30649630
37,00	37	EXD-2F02-3700-HP600	30649631
40,00	39	EXD-2F02-4000-HP600	30657122

## Konfigurierbare Merkmale



**Durchmesser:**  
Durchmesser in Abstufungen von 0,01 mm frei wählbar



**Spezifikation:**  
EXD-2F02-[Durchmesser]-HP600

**Beispiel:**  
EXD-2F02-1401-HP600

Werkzeugdurchmesser d<sub>1</sub> = 14,01 mm

## Abmessungen konfigurierbare Baureihe

d <sub>1</sub> min.	d <sub>1</sub> max.
9,00	50,00



# Schneidplatten EXD

Aus Vollhartmetall, innere Kühlmittelzufuhr  
Typ 04 - Iron

**Ausführung:**

Bohrerdurchmesser: 9,00 - 50,00 mm  
Bohrungstoleranz:  $\geq$  IT 10  
Beschichtung: HP240  
Schneidenanzahl: 2  
Anzahl Führungsfasen: 2  
Spitzenwinkel: 135°

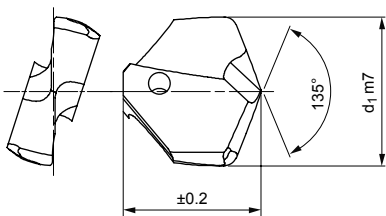

**Lagerhaltige Vorzugsbaureihe**

d <sub>1</sub> von 12,00 bis 23,00			
d <sub>1</sub> m7	Haltergröße D	Spezifikation	Bestell-Nr.
12,00	12	EXD-2F04-1200-HP240	30615775
14,00	14	EXD-2F04-1400-HP240	30612659
14,50	14,5	EXD-2F04-1450-HP240	30612660
17,00	17	EXD-2F04-1700-HP240	30612675
17,50	17	EXD-2F04-1750-HP240	30612676
18,00	18	EXD-2F04-1800-HP240	30612678
19,00	19	EXD-2F04-1900-HP240	30612682
19,10	19	EXD-2F04-1910-HP240	30645810
19,50	19	EXD-2F04-1950-HP240	30612686
20,50	20	EXD-2F04-2050-HP240	30612691
21,00	21	EXD-2F04-2100-HP240	30612694
21,50	21	EXD-2F04-2150-HP240	30612695
22,00	22	EXD-2F04-2200-HP240	30612697
23,00	23	EXD-2F04-2300-HP240	30612703

d <sub>1</sub> von 23,50 bis 33,00			
d <sub>1</sub> m7	Haltergröße D	Spezifikation	Bestell-Nr.
23,50	23	EXD-2F04-2350-HP240	30612705
24,00	24	EXD-2F04-2400-HP240	30612710
24,50	24	EXD-2F04-2450-HP240	30612711
25,00	25	EXD-2F04-2500-HP240	30612714
25,70	25	EXD-2F04-2570-HP240	30612717
26,00	26	EXD-2F04-2600-HP240	30612718
26,50	26	EXD-2F04-2650-HP240	30612719
28,00	28	EXD-2F04-2800-HP240	30612723
28,50	28	EXD-2F04-2850-HP240	30612725
29,00	29	EXD-2F04-2900-HP240	30612726
29,50	29	EXD-2F04-2950-HP240	30612727
30,00	30	EXD-2F04-3000-HP240	30612728
31,00	31	EXD-2F04-3100-HP240	30612732
33,00	33	EXD-2F04-3300-HP240	30649639

**Konfigurierbare Merkmale**



**Durchmesser:**  
Durchmesser in Abstufungen von 0,01 mm frei wählbar



**Spezifikation:**  
EXD-2F02-[Durchmesser]-HP600

**Beispiel:**  
EXD-2F02-1401-HP600

Werkzeugdurchmesser d<sub>1</sub> = 14,01 mm

**Abmessungen konfigurierbare Baureihe**

d <sub>1</sub> min.	d <sub>1</sub> max.
9,00	50,00

Maßangaben in mm.  
Schnittwertempfehlung siehe Kapitelende.  
Sonderausführungen und andere Beschichtungen auf Anfrage.

# Schneidplatten EXD

Aus Vollhartmetall, innere Kühlmittelzufuhr  
Typ 03 - Alu

## Ausführung:

Bohrerdurchmesser: 9,00 - 50,00 mm  
Bohrungstoleranz:  $\geq$  IT 10  
Beschichtung: HU310  
Schneidenanzahl: 2  
Anzahl Führungsfasen: 2  
Spitzenwinkel: 135°

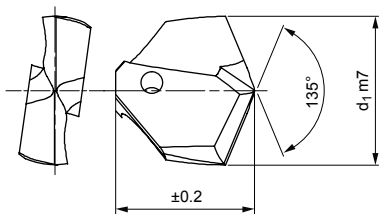

## Lagerhaltige Vorzugsbaureihe

d <sub>1</sub> von 13,00 bis 20,50			
d <sub>1</sub> m7	Haltergröße D	Spezifikation	Bestell-Nr.
13,00	13	EXD-2F03-1300-HU310	30612736
13,50	13,5	EXD-2F03-1350-HU310	30612737
14,00	14	EXD-2F03-1400-HU310	30612739
14,50	14,5	EXD-2F03-1450-HU310	30612740
15,00	15	EXD-2F03-1500-HU310	30612743
15,50	15	EXD-2F03-1550-HU310	30612745
16,00	16	EXD-2F03-1600-HU310	30612747
17,00	17	EXD-2F03-1700-HU310	30612754
17,50	17	EXD-2F03-1750-HU310	30612755
18,25	18	EXD-2F03-1825-HU310	30612759
18,50	18	EXD-2F03-1850-HU310	30612760
19,00	19	EXD-2F03-1900-HU310	30612762
20,00	20	EXD-2F03-2000-HU310	30612769
20,50	20	EXD-2F03-2050-HU310	30612771

d <sub>1</sub> von 21,00 bis 36,00			
d <sub>1</sub> m7	Haltergröße D	Spezifikation	Bestell-Nr.
21,00	21	EXD-2F03-2100-HU310	30612774
22,00	22	EXD-2F03-2200-HU310	30612777
22,50	22	EXD-2F03-2250-HU310	30612780
23,00	23	EXD-2F03-2300-HU310	30612783
23,50	23	EXD-2F03-2350-HU310	30612785
24,00	24	EXD-2F03-2400-HU310	30612789
24,50	24	EXD-2F03-2450-HU310	30612790
25,00	25	EXD-2F03-2500-HU310	30612793
26,00	26	EXD-2F03-2600-HU310	30612797
27,00	27	EXD-2F03-2700-HU310	30612799
29,50	29	EXD-2F03-2950-HU310	30612806
30,00	30	EXD-2F03-3000-HU310	30612807
34,00	34	EXD-2F03-3400-HU310	30649634
36,00	36	EXD-2F03-3600-HU310	30649636

## Konfigurierbare Merkmale



### Durchmesser:

Durchmesser in Abstufungen  
von 0,01 mm frei wählbar



### Spezifikation:

EXD-2F03-[Durchmesser]-HU310

### Beispiel:

EXD-2F02-1401-HU310

Werkzeugdurchmesser d<sub>1</sub> = 14,01 mm

## Abmessungen konfigurierbare Baureihe

d <sub>1</sub> min.	d <sub>1</sub> max.
9,00	50,00

Maßangaben in mm.

Schnittwertempfehlung siehe Kapitelende.

Sonderausführungen und andere Beschichtungen auf Anfrage.

# Schneidplattenhalter EXS

Mit Prismenaufnahme für EXD-Schneidplatten  
EXS100S, innere Kühlmittelzufuhr

## Ausführung:

Für Durchmesser:

9,00 - 50,99 mm

Schaftform:

nach ISO 9766

Wechselsystem:

Prismenaufnahme,  
Schneidenwechsel auf  
der Maschine möglich

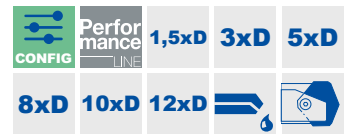
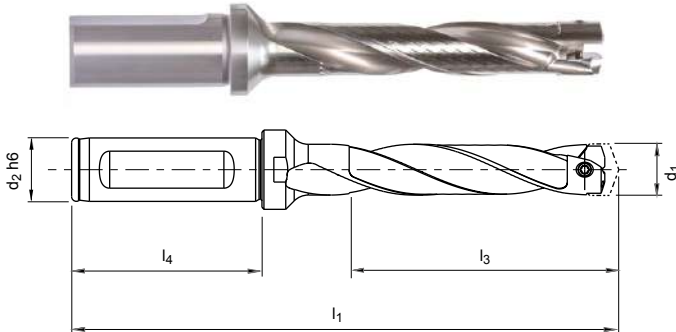

## Lagerhaltige Vorzugsbaureihe

Haltergröße D	Baumaße					Spezifikation	Bestell-Nr.
	Durchmesserbereich Schneidplatte d <sub>1</sub>	d <sub>2</sub> h6	l <sub>1</sub>	l <sub>3</sub>	l <sub>4</sub>		
9,00	9,00 - 9,49	12	110	48	45	EXS100S-0900-DR05-ZYL12-MN	30606451
9,50	9,50 - 9,99	12	113	50	45	EXS100S-0950-DR05-ZYL12-MN	30606452
10,00	10,00 - 10,49	16	99	32	48	EXS100S-1000-DR03-ZYL16-MN	30606442
10,00	10,00 - 10,49	16	120	53	48	EXS100S-1000-DR05-ZYL16-MN	30606453
10,50	10,50 - 10,99	16	122	55	48	EXS100S-1050-DR05-ZYL16-MN	30606454
11,00	11,00 - 11,49	16	126	58	48	EXS100S-1100-DR05-ZYL16-MN	30606455
11,00	11,00 - 11,49	16	160	92	48	EXS100S-1100-DR08-ZYL16-MN	30606465
11,50	11,50 - 11,99	16	105	36	48	EXS100S-1150-DR03-ZYL16-MN	30606445
12,00	12,00 - 12,49	16	107	38	48	EXS100S-1200-DR03-ZYL16-MN	30606446
12,00	12,00 - 12,49	16	132	63	48	EXS100S-1200-DR05-ZYL16-MN	30606457
12,00	12,00 - 12,49	16	169	100	48	EXS100S-1200-DR08-ZYL16-MN	30606467
12,50	12,50 - 12,99	16	109	39	48	EXS100S-1250-DR03-ZYL16-MN	30606448
12,50	12,50 - 12,99	16	135	65	48	EXS100S-1250-DR05-ZYL16-MN	30606458
12,50	12,50 - 12,99	16	174	104	48	EXS100S-1250-DR08-ZYL16-MN	30606468
13,00	13,00 - 13,49	16	112	41	48	EXS100S-1300-DR03-ZYL16-MN	30506951
13,00	13,00 - 13,49	16	138	68	48	EXS100S-1300-DR05-ZYL16-MN	30506973
13,00	13,00 - 13,49	16	178	108	48	EXS100S-1300-DR08-ZYL16-MN	30506995
13,00	13,00 - 13,49	16	232	162	48	EXS100S-1300-DR12-ZYL16-MN	30598705
13,50	13,50 - 13,99	16	211	140	48	EXS100S-1350-DR10-ZYL16-MN	30826088
13,50	13,50 - 13,99	16	239	168	48	EXS100S-1350-DR12-ZYL16-MN	30598706
14,00	14,00 - 14,49	16	116	44	48	EXS100S-1400-DR03-ZYL16-MN	30506953
14,00	14,00 - 14,49	16	144	73	48	EXS100S-1400-DR05-ZYL16-MN	30506975
14,00	14,00 - 14,49	16	187	116	48	EXS100S-1400-DR08-ZYL16-MN	30506997
14,00	14,00 - 14,49	16	245	174	48	EXS100S-1400-DR12-ZYL16-MN	30598707
14,50	14,50 - 14,99	16	95	23	48	EXS100S-1450-DR01-ZYL16-MN	30506931
14,50	14,50 - 14,99	16	147	75	48	EXS100S-1450-DR05-ZYL16-MN	30506976
15,00	15,00 - 15,99	20	124	48	50	EXS100S-1500-DR03-ZYL20-MN	30506955
15,00	15,00 - 15,99	20	155	80	50	EXS100S-1500-DR05-ZYL20-MN	30506977
15,00	15,00 - 15,99	20	203	128	50	EXS100S-1500-DR08-ZYL20-MN	30506999
15,00	15,00 - 15,99	20	237	162	50	EXS100S-1500-DR10-ZYL20-MN	30826091
15,00	15,00 - 15,99	20	267	192	50	EXS100S-1500-DR12-ZYL20-MN	30598709
16,00	16,00 - 16,99	20	102	26	50	EXS100S-1600-DR01-ZYL20-MN	30506933
16,00	16,00 - 16,99	20	128	51	50	EXS100S-1600-DR03-ZYL20-MN	30506956
16,00	16,00 - 16,99	20	161	85	50	EXS100S-1600-DR05-ZYL20-MN	30506978

Fortsetzung auf nächster Seite.

## Schneidplattenhalter EXS | EXS100, innere Kühlmittelzufuhr

Haltergröße D	Baumaße					Spezifikation	Bestell-Nr.
	Durchmesserbereich Schneidplatte d <sub>1</sub>	d <sub>2</sub> h6	l <sub>1</sub>	l <sub>3</sub>	l <sub>4</sub>		
16,00	16,00 - 16,99	20	212	136	50	EXS100S-1600-DR08-ZYL20-MN	30507000
16,00	16,00 - 16,99	20	246	170	50	EXS100S-1600-DR10-ZYL20-MN	30826092
17,00	17,00 - 17,99	20	105	27	50	EXS100S-1700-DR01-ZYL20-MN	30506934
17,00	17,00 - 17,99	20	132	54	50	EXS100S-1700-DR03-ZYL20-MN	30506957
17,00	17,00 - 17,99	20	168	90	50	EXS100S-1700-DR05-ZYL20-MN	30506979
17,00	17,00 - 17,99	20	222	144	50	EXS100S-1700-DR08-ZYL20-MN	30507001
17,00	17,00 - 17,99	20	258	180	50	EXS100S-1700-DR10-ZYL20-MN	30826093
17,00	17,00 - 17,99	20	294	216	50	EXS100S-1700-DR12-ZYL20-MN	30598711
18,00	18,00 - 18,99	25	142	57	56	EXS100S-1800-DR03-ZYL25-MN	30506958
18,00	18,00 - 18,99	25	180	95	56	EXS100S-1800-DR05-ZYL25-MN	30506980
18,00	18,00 - 18,99	25	237	152	56	EXS100S-1800-DR08-ZYL25-MN	30507002
18,00	18,00 - 18,99	25	313	228	56	EXS100S-1800-DR12-ZYL25-MN	30598712
19,00	19,00 - 19,99	25	116	30	56	EXS100S-1900-DR01-ZYL25-MN	30506937
19,00	19,00 - 19,99	25	146	60	56	EXS100S-1900-DR03-ZYL25-MN	30506959
19,00	19,00 - 19,99	25	186	100	56	EXS100S-1900-DR05-ZYL25-MN	30506981
19,00	19,00 - 19,99	25	246	160	56	EXS100S-1900-DR08-ZYL25-MN	30507003
20,00	20,00 - 20,99	25	151	63	56	EXS100S-2000-DR03-ZYL25-MN	30506960
20,00	20,00 - 20,99	25	192	105	56	EXS100S-2000-DR05-ZYL25-MN	30506982
20,00	20,00 - 20,99	25	255	168	56	EXS100S-2000-DR08-ZYL25-MN	30507004
20,00	20,00 - 20,99	25	297	210	56	EXS100S-2000-DR10-ZYL25-MN	30826096
20,00	20,00 - 20,99	25	339	252	56	EXS100S-2000-DR12-ZYL25-MN	30598714
21,00	21,00 - 21,99	25	121	33	56	EXS100S-2100-DR01-ZYL25-MN	30506939
21,00	21,00 - 21,99	25	155	66	56	EXS100S-2100-DR03-ZYL25-MN	30506961
21,00	21,00 - 21,99	25	198	110	56	EXS100S-2100-DR05-ZYL25-MN	30506983
21,00	21,00 - 21,99	25	264	176	56	EXS100S-2100-DR08-ZYL25-MN	30507005
21,00	21,00 - 21,99	25	308	220	56	EXS100S-2100-DR10-ZYL25-MN	30826097
22,00	22,00 - 22,99	25	125	35	56	EXS100S-2200-DR01-ZYL25-MN	30506940
22,00	22,00 - 22,99	25	159	69	56	EXS100S-2200-DR03-ZYL25-MN	30506962
22,00	22,00 - 22,99	25	205	115	56	EXS100S-2200-DR05-ZYL25-MN	30506984
22,00	22,00 - 22,99	25	274	184	56	EXS100S-2200-DR08-ZYL25-MN	30507006
23,00	23,00 - 23,99	25	127	36	56	EXS100S-2300-DR01-ZYL25-MN	30506941
23,00	23,00 - 23,99	25	211	120	56	EXS100S-2300-DR05-ZYL25-MN	30506985
23,00	23,00 - 23,99	25	379	288	56	EXS100S-2300-DR12-ZYL25-MN	30598717
24,00	24,00 - 24,99	32	171	75	60	EXS100S-2400-DR03-ZYL32-MN	30506964
24,00	24,00 - 24,99	32	221	125	60	EXS100S-2400-DR05-ZYL32-MN	30506986
24,00	24,00 - 24,99	32	296	200	60	EXS100S-2400-DR08-ZYL32-MN	30507008
24,00	24,00 - 24,99	32	396	300	60	EXS100S-2400-DR12-ZYL32-MN	30598718
25,00	25,00 - 25,99	32	136	39	60	EXS100S-2500-DR01-ZYL32-MN	30506943
25,00	25,00 - 25,99	32	176	78	60	EXS100S-2500-DR03-ZYL32-MN	30506965
25,00	25,00 - 25,99	32	227	130	60	EXS100S-2500-DR05-ZYL32-MN	30506987
25,00	25,00 - 25,99	32	305	208	60	EXS100S-2500-DR08-ZYL32-MN	30507009
25,00	25,00 - 25,99	32	409	312	60	EXS100S-2500-DR12-ZYL32-MN	30598719
26,00	26,00 - 26,99	32	139	41	60	EXS100S-2600-DR01-ZYL32-MN	30506944
26,00	26,00 - 26,99	32	180	81	60	EXS100S-2600-DR03-ZYL32-MN	30506966
26,00	26,00 - 26,99	32	233	135	60	EXS100S-2600-DR05-ZYL32-MN	30506988
26,00	26,00 - 26,99	32	314	216	60	EXS100S-2600-DR08-ZYL32-MN	30507010
26,00	26,00 - 26,99	32	368	270	60	EXS100S-2600-DR10-ZYL32-MN	30826102
27,00	27,00 - 27,99	32	184	84	60	EXS100S-2700-DR03-ZYL32-MN	30506967
27,00	27,00 - 27,99	32	324	224	60	EXS100S-2700-DR08-ZYL32-MN	30507011
28,00	28,00 - 28,99	32	188	87	60	EXS100S-2800-DR03-ZYL32-MN	30506968
28,00	28,00 - 28,99	32	246	145	60	EXS100S-2800-DR05-ZYL32-MN	30506990
28,00	28,00 - 28,99	32	449	348	60	EXS100S-2800-DR12-ZYL32-MN	30598722
29,00	29,00 - 29,99	32	402	300	60	EXS100S-2900-DR10-ZYL32-MN	30826105
30,00	30,00 - 30,99	32	197	93	60	EXS100S-3000-DR03-ZYL32-MN	30506970
30,00	30,00 - 30,99	32	351	248	60	EXS100S-3000-DR08-ZYL32-MN	30507014
30,00	30,00 - 30,99	32	413	310	60	EXS100S-3000-DR10-ZYL32-MN	30826106

Schneidplattenhalter EXS | EXS100, innere Kühlmittelzufuhr

Haltergröße D	Baumaße					Spezifikation	Bestell-Nr.
	Durchmesserbereich Schneidplatte d <sub>1</sub>	d <sub>2</sub> h <sub>6</sub>	l <sub>1</sub>	l <sub>3</sub>	l <sub>4</sub>		
30,00	30,00 - 30,99	32	475	372	60	EXS100S-3000-DR12-ZYL32-MN	30598724
31,00	31,00 - 31,99	32	264	160	60	EXS100S-3100-DR05-ZYL32-MN	30506993
32,00	32,00 - 32,99	32	271	165	60	EXS100S-3200-DR05-ZYL32-MN	30506994
32,00	32,00 - 32,99	32	436	330	60	EXS100S-3200-DR10-ZYL32-MN	30826108
32,00	32,00 - 32,99	32	502	396	60	EXS100S-3200-DR12-ZYL32-MN	30598726
33,00	33,00 - 33,99	32	209	102	60	EXS100S-3300-DR03-ZYL32-MN	30639232
34,00	34,00 - 34,99	32	283	175	60	EXS100S-3400-DR05-ZYL32-MN	30639237
35,00	35,00 - 35,99	32	218	108	60	EXS100S-3500-DR03-ZYL32-MN	30639234
36,00	36,00 - 36,99	32	222	111	60	EXS100S-3600-DR03-ZYL32-MN	30639235
37,00	37,00 - 38,99	40	318	195	70	EXS100S-3700-DR05-ZYL40-MN	30650258
39,00	39,00 - 40,99	40	249	123	70	EXS100S-3900-DR03-ZYL40-MN	30650254
41,00	41,00 - 42,99	40	257	129	70	EXS100S-4100-DR03-ZYL40-MN	30650255

Konfigurierbare Merkmale

**Längenausführung:**  
DR01 | DR03 | DR05 | DR08 |  
DR10 | DR12

**Spezifikation:**  
EXS100S-3500-[Längenausführung]-ZYL32-MN

Beispiel:  
EXS100S-3500-DR10-ZYL32-MN

Längenausführung 10xD

Abmessungen konfigurierbare Baureihe

Haltergröße D	Durchmesserbereich Schneidplatte d <sub>1</sub>	d <sub>2</sub> h <sub>6</sub>	l <sub>4</sub>	DR01		DR03		DR05		DR08		DR10		DR12		Spezifikation
				l <sub>1</sub>	l <sub>3</sub>	l <sub>1</sub>	l <sub>3</sub>	l <sub>1</sub>	l <sub>3</sub>	l <sub>1</sub>	l <sub>3</sub>	l <sub>1</sub>	l <sub>3</sub>	l <sub>1</sub>	l <sub>3</sub>	
9	9,00 - 9,49	12	45	77	15	92	29	110	48	138	76	-	-	-	-	EXS100S-0900-[Längenausführung]-ZYL12-MN
9,5	9,50 - 9,99	12	45	78	15	93	30	113	50	143	80	-	-	-	-	EXS100S-0950-[Längenausführung]-ZYL12-MN
10	10,00 - 10,49	16	48	83	16	99	32	120	53	151	84	-	-	-	-	EXS100S-1000-[Längenausführung]-ZYL16-MN
10,5	10,50 - 10,99	16	48	84	17	101	33	122	55	155	88	-	-	-	-	EXS100S-1050-[Längenausführung]-ZYL16-MN
11	11,00 - 11,49	16	48	86	18	103	35	126	58	160	92	-	-	-	-	EXS100S-1100-[Längenausführung]-ZYL16-MN
11,5	11,50 - 11,99	16	48	86	18	105	36	128	60	164	96	-	-	-	-	EXS100S-1150-[Längenausführung]-ZYL16-MN
12	12,00 - 12,49	16	48	88	19	107	38	132	63	169	100	-	-	-	-	EXS100S-1200-[Längenausführung]-ZYL16-MN
12,5	12,50 - 12,99	16	48	90	20	109	39	135	65	174	104	-	-	-	-	EXS100S-1250-[Längenausführung]-ZYL16-MN
13	13,00 - 13,49	16	48	91	21	112	41	138	68	178	108	205	135	232	162	EXS100S-1300-[Längenausführung]-ZYL16-MN
13,5	13,50 - 13,99	16	48	92	21	113	42	141	70	183	112	211	140	239	168	EXS100S-1350-[Längenausführung]-ZYL16-MN
14	14,00 - 14,49	16	48	93	22	116	44	144	73	187	116	216	145	245	174	EXS100S-1400-[Längenausführung]-ZYL16-MN
14,5	14,50 - 14,99	16	48	95	23	117	45	147	75	192	120	222	150	252	180	EXS100S-1450-[Längenausführung]-ZYL16-MN
15	15,00 - 15,99	20	50	99	24	124	48	155	80	203	128	237	162	267	192	EXS100S-1500-[Längenausführung]-ZYL20-MN
16	16,00 - 16,99	20	50	102	26	128	51	161	85	212	136	246	170	280	204	EXS100S-1600-[Längenausführung]-ZYL20-MN
17	17,00 - 17,99	20	50	105	27	132	54	168	90	222	144	258	180	294	216	EXS100S-1700-[Längenausführung]-ZYL20-MN
18	18,00 - 18,99	25	56	114	29	142	57	180	95	237	152	275	190	313	228	EXS100S-1800-[Längenausführung]-ZYL25-MN
19	19,00 - 19,99	25	56	116	30	146	60	186	100	246	160	286	200	326	240	EXS100S-1900-[Längenausführung]-ZYL25-MN
20	20,00 - 20,99	25	56	119	32	151	63	192	105	255	168	297	210	339	252	EXS100S-2000-[Längenausführung]-ZYL25-MN
21	21,00 - 21,99	25	56	121	33	155	66	198	110	264	176	308	220	352	264	EXS100S-2100-[Längenausführung]-ZYL25-MN
22	22,00 - 22,99	25	56	125	35	159	69	205	115	274	184	320	230	366	276	EXS100S-2200-[Längenausführung]-ZYL25-MN
23	23,00 - 23,99	25	56	127	36	163	72	211	120	283	192	331	240	379	288	EXS100S-2300-[Längenausführung]-ZYL25-MN
24	24,00 - 24,99	32	60	134	38	171	75	221	125	296	200	346	250	396	300	EXS100S-2400-[Längenausführung]-ZYL32-MN
25	25,00 - 25,99	32	60	136	39	176	78	227	130	305	208	357	260	409	312	EXS100S-2500-[Längenausführung]-ZYL32-MN
26	26,00 - 26,99	32	60	139	41	180	81	233	135	314	216	368	270	422	324	EXS100S-2600-[Längenausführung]-ZYL32-MN
27	27,00 - 27,99	32	60	142	42	184	84	240	140	324	224	380	280	436	336	EXS100S-2700-[Längenausführung]-ZYL32-MN

## Abmessungen konfigurierbare Baureihe

Haltegröße D	Durchmesserbereich Schneidplatte d <sub>1</sub>	d <sub>2</sub> h <sub>6</sub>	l <sub>4</sub>	DR01		DR03		DR05		DR08		DR10		DR12		Spezifikation
				l <sub>1</sub>	l <sub>3</sub>	l <sub>1</sub>	l <sub>3</sub>	l <sub>1</sub>	l <sub>3</sub>	l <sub>1</sub>	l <sub>3</sub>	l <sub>1</sub>	l <sub>3</sub>	l <sub>1</sub>	l <sub>3</sub>	
28	28,00 - 28,99	32	60	145	44	188	87	246	145	333	232	391	290	449	348	EXS100S-2800-[Längenausführung]-ZYL32-MN
29	29,00 - 29,99	32	60	147	45	192	90	252	150	342	240	402	300	462	360	EXS100S-2900-[Längenausführung]-ZYL32-MN
30	30,00 - 30,99	32	60	150	47	197	93	258	155	351	248	413	310	475	372	EXS100S-3000-[Längenausführung]-ZYL32-MN
31	31,00 - 31,99	32	60	152	48	201	96	264	160	360	256	424	320	488	384	EXS100S-3100-[Längenausführung]-ZYL32-MN
32	32,00 - 32,99	32	60	156	50	205	99	271	165	370	264	436	330	502	396	EXS100S-3200-[Längenausführung]-ZYL32-MN
33	33,00 - 33,99	32	60	158	51	209	102	277	170	379	272	447	340	515	408	EXS100S-3300-[Längenausführung]-ZYL32-MN
34	34,00 - 34,99	32	60	161	53	213	105	283	175	388	280	458	350	528	420	EXS100S-3400-[Längenausführung]-ZYL32-MN
35	35,00 - 35,99	32	60	163	54	218	108	289	180	397	288	469	360	541	432	EXS100S-3500-[Längenausführung]-ZYL32-MN
36	36,00 - 36,99	32	60	166	56	222	111	295	185	406	296	480	370	554	444	EXS100S-3600-[Längenausführung]-ZYL32-MN
37	37,00 - 38,99	40	70	182	59	240	117	318	195	435	312	515	390	591	468	EXS100S-3700-[Längenausführung]-ZYL40-MN
39	39,00 - 40,99	40	70	187	62	249	123	330	205	453	328	537	410	617	492	EXS100S-3900-[Längenausführung]-ZYL40-MN
41	41,00 - 42,99	40	70	193	65	257	129	343	215	472	344	560	430	644	516	EXS100S-4100-[Längenausführung]-ZYL40-MN
43	43,00 - 44,99	40	70	198	68	265	135	355	225	490	360	582	440	670	540	EXS100S-4300-[Längenausführung]-ZYL40-MN
45	45,00 - 46,99	40	70	203	71	274	141	367	235	508	376	604	470	696	564	EXS100S-4500-[Längenausführung]-ZYL40-MN
47	47,00 - 48,99	40	70	211	74	284	147	382	245	529	392	627	490	725	588	EXS100S-4700-[Längenausführung]-ZYL40-MN
49	49,00 - 50,99	40	70	216	77	293	153	394	255	547	408	649	510	751	612	EXS100S-4900-[Längenausführung]-ZYL40-MN

# Ersatzteile

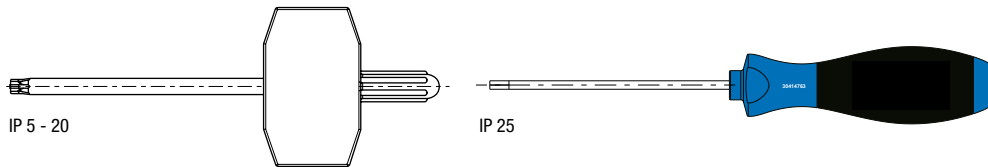

## Schraubendreher

Torxgröße TORX PLUS®	Bestell-Nr.
5 IP	30701706
6 IP	30233940
7 IP	30233941
8 IP	30233942
9 IP	30234886
10 IP	30233943
15 IP	30233944
20 IP	30233945
25 IP	31197123

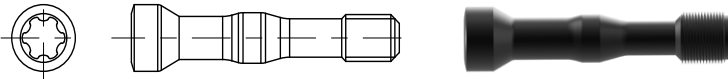

## Spannschraube

Ø-Bereich	TORX PLUS® Größe	Bestell-Nr.	Spezifikation	Anzugsmoment [Nm]
8,00 - 8,99	5 IP	30604440	M1.2X7.5-TX5-IP	0,2
9,00 - 10,99	5 IP	30546309	M1.2X8.5-TX5-IP	0,2
11,00 - 12,99	6 IP	30604180	M1.6X10.5-TX6-IP	0,4
13,00 - 13,99	7 IP	30510826	M2x12-TX7-IP	0,6
14,00 - 15,99	8 IP	30510827	M2.2x13-TX8-IP	0,9
16,00 - 18,99	8 IP	30495432	M2.5x15-TX8-IP	1,2
19,00 - 21,99	9 IP	30510829	M3x18-TX9-IP	2,2
22,00 - 24,99	10 IP	30510830	M3.5x21-TX10-IP	3,3
25,00 - 27,99	15 IP	30510831	M4x24-TX15-IP	5,0
28,00 - 30,99	15 IP	30510832	M4.5x27-TX15-IP	5,7
31,00 - 32,99	20 IP	30510833	M5x30-TX20-IP	7,5
33,00 - 36,99	20 IP	30651830	M5X32-TX20-IP	7,5
37,00 - 44,99	25 IP	30651399	M6X35-TX25-IP	15,0
45,00 - 50,99	25 IP	30651510	M6X43-TX25-IP	15,0

# Schnittwertempfehlung für Schneidplatten EXD

Vorschub und Schnittgeschwindigkeit

## Typ 01 - Steel

MZG*	Werkstoff	Festigkeit/Härte [N/mm <sup>2</sup> ] [HRC]
P	P1.1 Bau-, Automaten-, Einsatz- und Vergütungsstähle, unlegiert	< 700
	P1.2 Bau-, Automaten-, Einsatz- und Vergütungsstähle, unlegiert	< 1.200
	P2.1 Nitrier-, Einsatz- und Vergütungsstähle, legiert	< 900
	P2.2 Nitrier-, Einsatz- und Vergütungsstähle, legiert	< 1.400
	P3.1 Werkzeug-, Wälzlager-, Feder- und Schnellarbeitsstähle**	< 800
	P3.2 Werkzeug-, Wälzlager-, Feder- und Schnellarbeitsstähle**	< 1.000
	P3.3 Werkzeug-, Wälzlager-, Feder- und Schnellarbeitsstähle**	< 1.500
	P5.1 Stahlguss	
	K	K1.1 Gusseisen mit Lamellengraphit (Grauguss), GJL
K2.1 Gusseisen mit Kugelgraphit, GJS		< 500
K2.2 Gusseisen mit Kugelgraphit, GJS		≤ 800
K2.3 Gusseisen mit Kugelgraphit, GJS		> 800
K3.1 Gusseisen mit Vermiculargraphit, GJV; Temperguss, GJM		< 500
K3.2 Gusseisen mit Vermiculargraphit, GJV; Temperguss, GJM		> 500

## Typ 05 - Steel-Pyramid

MZG*	Werkstoff	Festigkeit/Härte [N/mm <sup>2</sup> ] [HRC]	
P	P1.1 Bau-, Automaten-, Einsatz- und Vergütungsstähle, unlegiert	< 700	
	P1.2 Bau-, Automaten-, Einsatz- und Vergütungsstähle, unlegiert	< 1.200	
	P2.1 Nitrier-, Einsatz- und Vergütungsstähle, legiert	< 900	
	P2.2 Nitrier-, Einsatz- und Vergütungsstähle, legiert	< 1.400	
	P3.1 Werkzeug-, Wälzlager-, Feder- und Schnellarbeitsstähle**	< 800	
	P3.2 Werkzeug-, Wälzlager-, Feder- und Schnellarbeitsstähle**	< 1.000	
	P3.3 Werkzeug-, Wälzlager-, Feder- und Schnellarbeitsstähle**	< 1.500	
	K	K1.1 Gusseisen mit Lamellengraphit (Grauguss), GJL	< 300
		K2.1 Gusseisen mit Kugelgraphit, GJS	< 500
K2.2 Gusseisen mit Kugelgraphit, GJS		≤ 800	
K2.3 Gusseisen mit Kugelgraphit, GJS		> 800	

## Typ 10 - Uni, Form EK

MZG*	Werkstoff	Festigkeit/Härte [N/mm <sup>2</sup> ] [HRC]	
P	P1.1 Bau-, Automaten-, Einsatz- und Vergütungsstähle, unlegiert	< 700	
	P1.2 Bau-, Automaten-, Einsatz- und Vergütungsstähle, unlegiert	< 1.200	
	P2.1 Nitrier-, Einsatz- und Vergütungsstähle, legiert	< 900	
	P2.2 Nitrier-, Einsatz- und Vergütungsstähle, legiert	< 1.400	
	P3.1 Werkzeug-, Wälzlager-, Feder- und Schnellarbeitsstähle**	< 800	
	P3.2 Werkzeug-, Wälzlager-, Feder- und Schnellarbeitsstähle**	< 1.000	
	P3.3 Werkzeug-, Wälzlager-, Feder- und Schnellarbeitsstähle**	< 1.500	
	K	K1.1 Gusseisen mit Lamellengraphit (Grauguss), GJL	< 300
		K2.1 Gusseisen mit Kugelgraphit, GJS	< 500
K2.2 Gusseisen mit Kugelgraphit, GJS		≤ 800	
K2.3 Gusseisen mit Kugelgraphit, GJS		> 800	

\* MILLER Zerspanungsgruppen

\*\* Wenn die Legierungsbestandteile Cr, Mo, Ni, V, W in Summe > 8 %, dann die nächst höhere MILLER Zerspanungsgruppe wählen.



	Schnittgeschwindigkeit $v_c$ [m/min]				Vorschub $f$ [mm] bei Bohrerdurchmesser					
	Innenkühlung	Außenkühlung	MMS	Luft	8,00	11,50	16,50	24,00	34,50	50,00
	<b>100</b>	<b>90</b>	<b>90</b>		0,20	0,26	0,31	0,36	0,38	0,39
	<b>90</b>	<b>75</b>	<b>75</b>		0,25	0,32	0,39	0,45	0,47	0,49
	<b>100</b>	<b>85</b>	<b>85</b>		0,24	0,30	0,37	0,43	0,45	0,46
	<b>70</b>	<b>60</b>	<b>60</b>		0,19	0,24	0,29	0,34	0,35	0,36
	<b>75</b>	<b>65</b>	<b>65</b>		0,22	0,27	0,33	0,38	0,40	0,42
	<b>60</b>	<b>55</b>	<b>55</b>		0,18	0,22	0,27	0,31	0,33	0,34
	<b>60</b>	<b>45</b>	<b>50</b>		0,14	0,18	0,21	0,24	0,25	0,26
	<b>100</b>	<b>85</b>	<b>85</b>		0,24	0,30	0,37	0,43	0,45	0,46
	<b>95</b>	<b>70</b>	<b>70</b>	<b>70</b>	0,25	0,33	0,41	0,47	0,49	0,51
	<b>130</b>	<b>80</b>	<b>95</b>	<b>95</b>	0,24	0,30	0,37	0,43	0,46	0,47
	<b>80</b>	<b>60</b>	<b>60</b>		0,21	0,26	0,32	0,37	0,39	0,40
	<b>50</b>	<b>30</b>	<b>40</b>		0,14	0,18	0,21	0,24	0,26	0,26
	<b>70</b>	<b>65</b>	<b>65</b>		0,22	0,28	0,35	0,40	0,42	0,43
	<b>65</b>	<b>55</b>	<b>55</b>		0,18	0,23	0,27	0,32	0,33	0,34

	Schnittgeschwindigkeit $v_c$ [m/min]				Vorschub $f$ [mm] bei Bohrerdurchmesser					
	Innenkühlung	Außenkühlung	MMS	Luft	14,00	16,50	19,50	23,00	27,00	32,00
	<b>120</b>	<b>110</b>	<b>110</b>		0,26	0,29	0,31	0,33	0,34	0,34
	<b>110</b>	<b>90</b>	<b>90</b>		0,33	0,36	0,38	0,41	0,42	0,43
	<b>120</b>	<b>100</b>	<b>100</b>		0,31	0,34	0,36	0,38	0,40	0,41
	<b>90</b>	<b>80</b>	<b>80</b>		0,28	0,30	0,33	0,35	0,36	0,37
	<b>95</b>	<b>70</b>	<b>70</b>	<b>70</b>	0,39	0,43	0,46	0,49	0,51	0,52
	<b>110</b>	<b>70</b>	<b>85</b>	<b>85</b>	0,36	0,40	0,43	0,45	0,47	0,48

	Schnittgeschwindigkeit $v_c$ [m/min]				Vorschub $f$ [mm] bei Bohrerdurchmesser					
	Innenkühlung	Außenkühlung	MMS	Luft	10,00	13,00	16,00	21,00	26,00	33,00
	<b>120</b>	<b>110</b>	<b>110</b>		0,22	0,25	0,28	0,31	0,34	0,35
	<b>110</b>	<b>90</b>	<b>90</b>		0,27	0,31	0,35	0,39	0,42	0,43
	<b>120</b>	<b>100</b>	<b>100</b>		0,25	0,29	0,33	0,37	0,40	0,41
	<b>90</b>	<b>80</b>	<b>80</b>		0,23	0,26	0,30	0,33	0,36	0,37
	<b>95</b>	<b>70</b>	<b>70</b>	<b>70</b>	0,31	0,36	0,42	0,47	0,51	0,52
	<b>110</b>	<b>70</b>	<b>85</b>	<b>85</b>	0,29	0,34	0,39	0,43	0,47	0,48

Die angegebenen Schnittwerte sind Richtwerte.

Die für den jeweiligen Bearbeitungsfall optimalen Daten sollten im Versuch oder während der Bearbeitung ermittelt werden.

# Schnittwertempfehlung für Schneidplatten EXD

Vorschub und Schnittgeschwindigkeit

## Typ 02 - Inox

MZG*	Werkstoff	Festigkeit/Härte [N/mm <sup>2</sup> ] [HRC]
P	P1.1 Bau-, Automaten-, Einsatz- und Vergütungsstähle, unlegiert	< 700
	P1.2 Bau-, Automaten-, Einsatz- und Vergütungsstähle, unlegiert	< 1.200
	P2.1 Nitrier-, Einsatz- und Vergütungsstähle, legiert	< 900
	P2.2 Nitrier-, Einsatz- und Vergütungsstähle, legiert	< 1.400
	P3.1 Werkzeug-, Wälzlager-, Feder- und Schnellarbeitsstähle**	< 800
	P3.2 Werkzeug-, Wälzlager-, Feder- und Schnellarbeitsstähle**	< 1.000
	P3.3 Werkzeug-, Wälzlager-, Feder- und Schnellarbeitsstähle**	< 1.500
	P4.1 Rostfreie Stähle, ferritisch und martensitisch	
	P5.1 Stahlguss	
	P6.1 Rostfreier Stahlguss, ferritisch und martensitisch	
M	M1.1 Rostfreie Stähle, austenitisch	< 700
	M1.2 Rostfreie Stähle, ferritisch/austenitisch (Duplex)	< 1.000
	M2.1 Rostfreier Stahlguss, austenitisch	< 700
	M3.1 Rostfreier Stahlguss, ferritisch/austenitisch (Duplex)	< 1.000
K	K1.1 Gusseisen mit Lamellengraphit (Grauguss), GJL	< 300
	K2.1 Gusseisen mit Kugelgraphit, GJS	< 500
	K2.2 Gusseisen mit Kugelgraphit, GJS	≤ 800
	K2.3 Gusseisen mit Kugelgraphit, GJS	> 800
	K3.1 Gusseisen mit Vermiculargraphit, GJV; Temperguss, GJM	< 500
	K3.2 Gusseisen mit Vermiculargraphit, GJV; Temperguss, GJM	> 500

## Typ 03 - Alu

MZG*	Werkstoff	Festigkeit/Härte [N/mm <sup>2</sup> ] [HRC]
N1	N1.1 Aluminium, unlegiert und legiert < 3 % Si	
	N1.2 Aluminium, legiert ≤ 7 % Si	
	N1.3 Aluminium, legiert > 7-12 % Si	
	N1.4 Aluminium, legiert > 12 % Si	
N2	N2.1 Kupfer, unlegiert und niedriglegiert	< 300
	N2.2 Kupfer, legiert	> 300
	N2.3 Messing, Bronze, Rotguss	< 1.200

## Typ 04 - Iron

MZG*	Werkstoff	Festigkeit/Härte [N/mm <sup>2</sup> ] [HRC]
K	K1.1 Gusseisen mit Lamellengraphit (Grauguss), GJL	< 300
	K2.1 Gusseisen mit Kugelgraphit, GJS	< 500
	K2.2 Gusseisen mit Kugelgraphit, GJS	≤ 800
	K2.3 Gusseisen mit Kugelgraphit, GJS	> 800
	K3.1 Gusseisen mit Vermiculargraphit, GJV; Temperguss, GJM	< 500
	K3.2 Gusseisen mit Vermiculargraphit, GJV; Temperguss, GJM	> 500

\* MILLER Zerspanungsgruppen

\*\* Wenn die Legierungsbestandteile Cr, Mo, Ni, V, W in Summe > 8 %, dann die nächst höhere MILLER Zerspanungsgruppe wählen.

	Schnittgeschwindigkeit $v_c$ [m/min]				Vorschub $f$ [mm] bei Bohrerdurchmesser					
	Innenkühlung	Außenkühlung	MMS	Luft	9,00	12,00	16,00	21,00	27,50	36,00
	<b>100</b>	<b>90</b>	<b>90</b>		0,19	0,23	0,27	0,30	0,32	0,33
	<b>90</b>	<b>75</b>	<b>75</b>		0,24	0,29	0,34	0,38	0,40	0,41
	<b>100</b>	<b>85</b>	<b>85</b>		0,23	0,27	0,32	0,36	0,38	0,39
	<b>70</b>	<b>60</b>	<b>60</b>		0,18	0,22	0,25	0,28	0,30	0,31
	<b>75</b>	<b>65</b>	<b>65</b>		0,20	0,24	0,29	0,32	0,34	0,35
	<b>60</b>	<b>55</b>	<b>55</b>		0,17	0,20	0,23	0,26	0,28	0,29
	<b>60</b>	<b>45</b>	<b>50</b>		0,13	0,16	0,18	0,20	0,21	0,22
	<b>60</b>	<b>45</b>	<b>50</b>		0,13	0,16	0,19	0,21	0,23	0,23
	<b>100</b>	<b>85</b>	<b>85</b>		0,23	0,27	0,32	0,36	0,38	0,39
	<b>60</b>	<b>45</b>	<b>50</b>		0,13	0,16	0,19	0,21	0,23	0,23
	<b>55</b>	<b>35</b>	<b>35</b>		0,15	0,18	0,22	0,24	0,26	0,27
	<b>50</b>	<b>30</b>	<b>30</b>		0,13	0,16	0,19	0,21	0,22	0,23
	<b>55</b>	<b>35</b>	<b>35</b>		0,15	0,18	0,22	0,24	0,26	0,27
	<b>50</b>	<b>30</b>	<b>30</b>		0,13	0,16	0,19	0,21	0,22	0,23
	<b>110</b>	<b>75</b>	<b>75</b>	<b>75</b>	0,27	0,34	0,40	0,45	0,49	0,50
	<b>145</b>	<b>90</b>	<b>110</b>	<b>110</b>	0,26	0,31	0,37	0,42	0,45	0,46
	<b>90</b>	<b>70</b>	<b>70</b>		0,22	0,27	0,32	0,36	0,38	0,39
	<b>55</b>	<b>35</b>	<b>45</b>		0,15	0,18	0,21	0,23	0,25	0,26
	<b>80</b>	<b>70</b>	<b>70</b>		0,24	0,29	0,34	0,38	0,41	0,42
	<b>70</b>	<b>65</b>	<b>65</b>		0,19	0,23	0,27	0,30	0,33	0,33

	Schnittgeschwindigkeit $v_c$ [m/min]				Vorschub $f$ [mm] bei Bohrerdurchmesser					
	Innenkühlung	Außenkühlung	MMS	Luft	9,00	12,00	16,00	21,00	27,50	36,00
	<b>300</b>	<b>200</b>	<b>250</b>		0,19	0,23	0,27	0,30	0,32	0,33
	<b>250</b>	<b>180</b>	<b>200</b>		0,25	0,30	0,35	0,40	0,43	0,43
	<b>220</b>	<b>150</b>	<b>180</b>		0,25	0,30	0,35	0,40	0,43	0,43
	<b>180</b>	<b>120</b>	<b>150</b>		0,25	0,30	0,35	0,40	0,43	0,43
	<b>140</b>	<b>100</b>			0,19	0,23	0,27	0,30	0,32	0,33
	<b>120</b>	<b>90</b>			0,25	0,30	0,35	0,40	0,43	0,43
	<b>200</b>	<b>160</b>	<b>160</b>	<b>120</b>	0,30	0,37	0,44	0,50	0,54	0,55

	Schnittgeschwindigkeit $v_c$ [m/min]				Vorschub $f$ [mm] bei Bohrerdurchmesser					
	Innenkühlung	Außenkühlung	MMS	Luft	9,00	12,00	16,00	21,00	27,50	36,00
	<b>120</b>	<b>85</b>	<b>85</b>	<b>85</b>	0,37	0,45	0,53	0,60	0,65	0,66
	<b>160</b>	<b>100</b>	<b>120</b>	<b>120</b>	0,34	0,42	0,49	0,55	0,59	0,61
	<b>100</b>	<b>75</b>	<b>75</b>		0,30	0,36	0,42	0,48	0,51	0,52
	<b>60</b>	<b>40</b>	<b>50</b>		0,20	0,24	0,28	0,31	0,34	0,34
	<b>90</b>	<b>80</b>	<b>80</b>		0,32	0,39	0,46	0,51	0,55	0,56
	<b>80</b>	<b>70</b>	<b>70</b>		0,26	0,31	0,36	0,40	0,43	0,44

Die angegebenen Schnittwerte sind Richtwerte.

Die für den jeweiligen Bearbeitungsfall optimalen Daten sollten im Versuch oder während der Bearbeitung ermittelt werden.

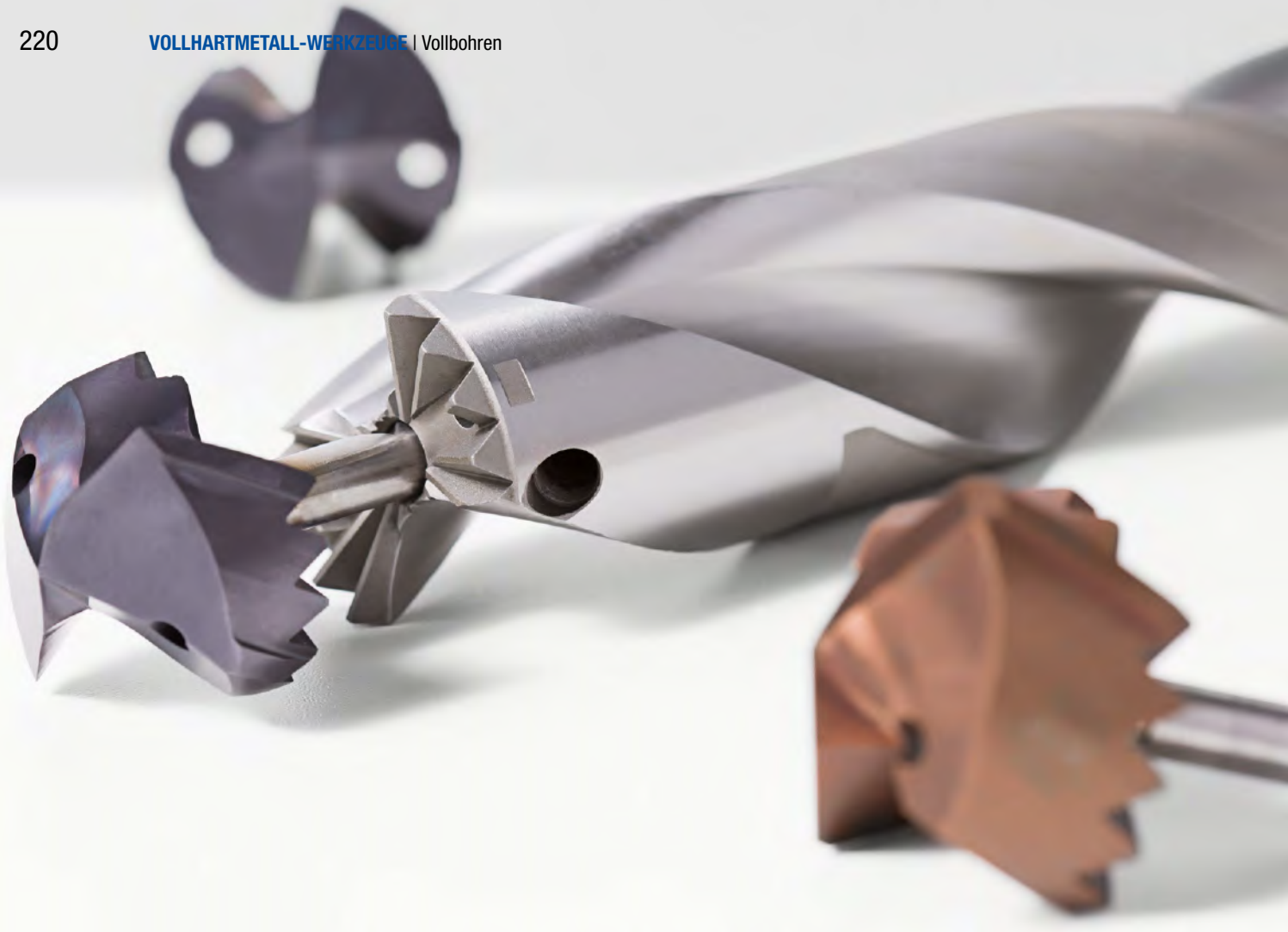

# WECHSELKOPFBOHRER TTD

## Minimierter Einsatz von Hartmetall bei höchster Stabilität & Präzision

Der Wechselkopfbohrer TTD erreicht das Leistungs- und Qualitätsniveau von Vollhartmetallbohrern. Gleichzeitig sorgt der auf die Wechselbohrköpfe reduzierte Einsatz des Hartmetalls für reduzierte Werkzeugkosten.

Im Mittelpunkt des Wechselkopfbohrers TTD steht die Trennstelle TTS (Torque Transfer System), die eine extrem stabile Verbindung garantiert. Sie ist gekennzeichnet durch eine optimale Drehmomentübertragung sowie hohe Wechsel- und Rundlaufgenauigkeiten.

Die Standardbaureihen des Wechselkopfbohrers TTD umfassen die Bohrtiefen 1xD, 3xD, 5xD, 8xD und 12xD. Mit fünf verschiedenen Wechselbohrköpfen werden auch problematische Bearbeitungsaufgaben in nahezu allen Werkstoffen im Durchmesserbereich von zwölf bis 45 mm abgedeckt.

Die Bohrköpfe weisen eine optimale Zentrierfähigkeit auf und die Späne werden durch den besonderen Facettenanschliff sicher über die Spanräume des TTS-Halters abgeleitet. Darüber hinaus wird ein sehr ruhiger Lauf in der Bohrung durch die Drei- bzw. Vierfasengeometrie begünstigt. Die Kombination dieser Eigenschaften ermöglicht hohe Standzeiten und Bohrerergebnisse auf höchstem Niveau.

## Werkzeugfeatures im Detail

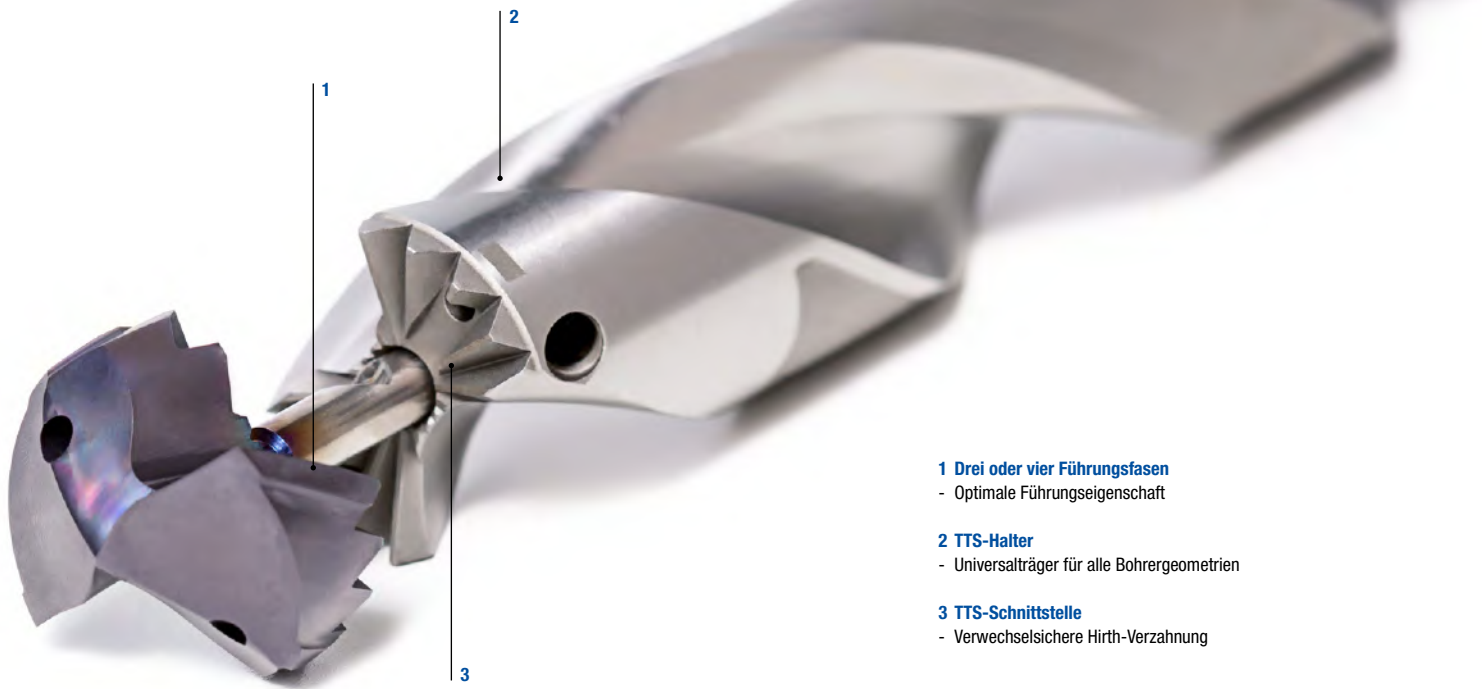

### 1 Drei oder vier Führungsfasen

- Optimale Führungseigenschaft

### 2 TTS-Halter

- Universalträger für alle Bohrergeometrien

### 3 TTS-Schnittstelle

- Verwechselsichere Hirth-Verzahnung



### AUF EINEN BLICK

- Ab Lager verfügbar
- $\emptyset$ -Bereich 12,00 bis 45,00 mm
- Bohrtiefen 1 | 3 | 5 | 8 und 12xD
- Mit Innenkühlung
- Einfaches Handling
- Kopfwechsel in der Maschine möglich

### LEISTUNGSMERKMALE

- Gleiche Leistungsfähigkeit wie VHM-Bohrer
- Hohe Rundlaufgenauigkeit
- Gute Positionsgenauigkeit
- Hohe Drehmomentübertragung

### VORTEILE

- Bei Bedarf nachschleifbar
- Verwechslungssicherer Kopfwechsel
- Ein Wechselkopfhalter für unterschiedliche Bohrköpfe
- Nahezu alle Bohrergeometrien realisierbar

# Wechselbohrkopf TTD

Aus Vollhartmetall, innere Kühlmittelzufuhr  
Typ 01P - Uni-Plus

## Ausführung:

Bohrerdurchmesser: 12,00 - 45,00 mm  
Bohrungstoleranz:  $\geq IT 9$   
Beschichtung: MxP  
Schneidenanzahl: 2  
Anzahl Führungsfasen: 4  
Spitzenwinkel: 140°

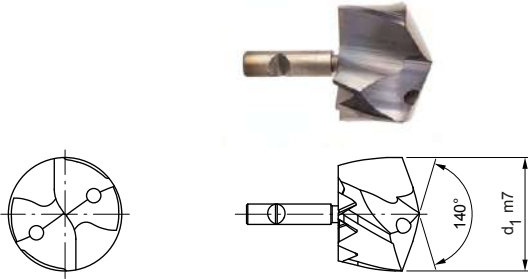

## Lagerhaltige Vorzugsbaureihe

d <sub>1</sub> von 12,00 bis 21,00		
d <sub>1</sub> m7	Spezifikation	Bestell-Nr.
12,00	TTD-4F01P-1200-MxP	31005011
13,50	TTD-4F01P-1350-MxP	31005026
14,00	TTD-4F01P-1400-MxP	31005031
14,50	TTD-4F01P-1450-MxP	31005036
15,00	TTD-4F01P-1500-MxP	31005041
15,50	TTD-4F01P-1550-MxP	31005046
15,60	TTD-4F01P-1560-MxP	31005047
15,80	TTD-4F01P-1580-MxP	31005049
16,00	TTD-4F01P-1600-MxP	31005051
16,50	TTD-4F01P-1650-MxP	31005056
17,00	TTD-4F01P-1700-MxP	31005061
17,50	TTD-4F01P-1750-MxP	31005066
17,70	TTD-4F01P-1770-MxP	31005068
17,80	TTD-4F01P-1780-MxP	31005069
18,00	TTD-4F01P-1800-MxP	31005071
18,50	TTD-4F01P-1850-MxP	31005076
18,80	TTD-4F01P-1880-MxP	31005079
19,00	TTD-4F01P-1900-MxP	31005081
19,50	TTD-4F01P-1950-MxP	31005086
19,70	TTD-4F01P-1970-MxP	31005088
20,00	TTD-4F01P-2000-MxP	31005091
20,50	TTD-4F01P-2050-MxP	31005096
21,00	TTD-4F01P-2100-MxP	31005101

d <sub>1</sub> von 21,50 bis 40,00		
d <sub>1</sub> m7	Spezifikation	Bestell-Nr.
21,50	TTD-4F01P-2150-MxP	31005106
22,00	TTD-4F01P-2200-MxP	31005111
22,50	TTD-4F01P-2250-MxP	31005116
23,00	TTD-4F01P-2300-MxP	31005121
24,00	TTD-4F01P-2400-MxP	31005131
24,50	TTD-4F01P-2450-MxP	31005136
25,00	TTD-4F01P-2500-MxP	31005141
25,40	TTD-4F01P-2540-MxP	31005145
25,50	TTD-4F01P-2550-MxP	31005146
26,00	TTD-4F01P-2600-MxP	31005151
26,50	TTD-4F01P-2650-MxP	31005156
27,00	TTD-4F01P-2700-MxP	31005161
28,00	TTD-4F01P-2800-MxP	31005171
28,50	TTD-4F01P-2850-MxP	31005176
30,00	TTD-4F01P-3000-MxP	31005191
30,70	TTD-4F01P-3070-MxP	31005198
31,00	TTD-4F01P-3100-MxP	31005201
32,00	TTD-4F01P-3200-MxP	31005211
33,00	TTD-4F01P-3300-MxP	31005213
37,00	TTD-4F01P-3700-MxP	31005221
38,50	TTD-4F01P-3850-MxP	31005224
39,00	TTD-4F01P-3900-MxP	31005225
40,00	TTD-4F01P-4000-MxP	31005227

## Konfigurierbare Merkmale



**Durchmesser:**  
Durchmesser in Abstufungen  
von 0,01 mm frei wählbar



### Spezifikation:

TTD-4F01P-[Durchmesser]-MxP

## Abmessungen konfigurierbare Baureihe

d <sub>1</sub> min.	d <sub>1</sub> max.
12,00	45,00

### Beispiel:

TTD-4F01P-1401-MxP

Werkzeugdurchmesser d<sub>1</sub> = 14,01 mm

# Wechselbohrkopf TTD

Aus Vollhartmetall, innere Kühlmittelzufuhr  
Typ 04 - Steel

## Ausführung:

Bohrerdurchmesser: 12,00 - 45,00 mm  
Bohrungstoleranz:  $\geq IT 9$   
Beschichtung: MxP  
Schneidenanzahl: 2  
Anzahl Führungsfasen: 3  
Spitzenwinkel: 138°

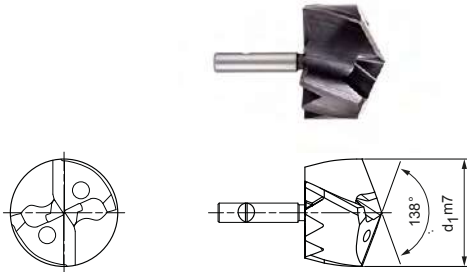

## Lagerhaltige Vorzugsbaureihe

d <sub>1</sub> von 12,00 bis 17,00		
d <sub>1</sub> m7	Spezifikation	Bestell-Nr.
12,00	TTD-3F04-1200-MxP	30841818
12,10	TTD-3F04-1210-MxP	30841905
12,20	TTD-3F04-1220-MxP	30841906
12,50	TTD-3F04-1250-MxP	30841819
12,80	TTD-3F04-1280-MxP	30841910
13,00	TTD-3F04-1300-MxP	30841821
13,10	TTD-3F04-1310-MxP	30841912
13,20	TTD-3F04-1320-MxP	30841913
13,50	TTD-3F04-1350-MxP	30841822
14,00	TTD-3F04-1400-MxP	30841824
14,10	TTD-3F04-1410-MxP	30841919
14,20	TTD-3F04-1420-MxP	30841920
14,30	TTD-3F04-1430-MxP	30841921
14,40	TTD-3F04-1440-MxP	30841922
14,50	TTD-3F04-1450-MxP	30841825
14,70	TTD-3F04-1470-MxP	30841826
14,80	TTD-3F04-1480-MxP	30841924
15,00	TTD-3F04-1500-MxP	30841827
15,10	TTD-3F04-1510-MxP	30841926
15,20	TTD-3F04-1520-MxP	30841927
15,50	TTD-3F04-1550-MxP	30841828
15,70	TTD-3F04-1570-MxP	30841829
15,80	TTD-3F04-1580-MxP	30841931
16,00	TTD-3F04-1600-MxP	30841830
16,10	TTD-3F04-1610-MxP	30841933
16,20	TTD-3F04-1620-MxP	30841934
16,30	TTD-3F04-1630-MxP	30841935
16,40	TTD-3F04-1640-MxP	30841936
16,50	TTD-3F04-1650-MxP	30841831
16,60	TTD-3F04-1660-MxP	30841937
16,70	TTD-3F04-1670-MxP	30841832
16,80	TTD-3F04-1680-MxP	30841938
17,00	TTD-3F04-1700-MxP	30841833

d <sub>1</sub> von 17,10 bis 21,40		
d <sub>1</sub> m7	Spezifikation	Bestell-Nr.
17,10	TTD-3F04-1710-MxP	30841940
17,30	TTD-3F04-1730-MxP	30841942
17,50	TTD-3F04-1750-MxP	30841834
17,60	TTD-3F04-1760-MxP	30841944
17,70	TTD-3F04-1770-MxP	30841835
17,80	TTD-3F04-1780-MxP	30841945
18,00	TTD-3F04-1800-MxP	30841836
18,10	TTD-3F04-1810-MxP	30841947
18,20	TTD-3F04-1820-MxP	30841948
18,30	TTD-3F04-1830-MxP	30841949
18,40	TTD-3F04-1840-MxP	30841950
18,50	TTD-3F04-1850-MxP	30841837
18,80	TTD-3F04-1880-MxP	30841952
18,90	TTD-3F04-1890-MxP	30841953
19,00	TTD-3F04-1900-MxP	30841839
19,20	TTD-3F04-1920-MxP	30841955
19,30	TTD-3F04-1930-MxP	30841956
19,50	TTD-3F04-1950-MxP	30841840
19,70	TTD-3F04-1970-MxP	30841841
19,80	TTD-3F04-1980-MxP	30841959
19,90	TTD-3F04-1990-MxP	30841960
20,00	TTD-3F04-2000-MxP	30841842
20,10	TTD-3F04-2010-MxP	30841961
20,20	TTD-3F04-2020-MxP	30841962
20,30	TTD-3F04-2030-MxP	30841963
20,40	TTD-3F04-2040-MxP	30841964
20,50	TTD-3F04-2050-MxP	30841843
20,60	TTD-3F04-2060-MxP	30841965
20,70	TTD-3F04-2070-MxP	30841844
21,00	TTD-3F04-2100-MxP	30841845
21,10	TTD-3F04-2110-MxP	30841968
21,20	TTD-3F04-2120-MxP	30841969
21,40	TTD-3F04-2140-MxP	30841971

Fortsetzung auf nächster Seite.

## Wechselbohrkopf TTD aus Vollhartmetall, innere Kühlmittelzufuhr - Typ 04

d <sub>1</sub> von 21,50 bis 26,10		
d <sub>1</sub> m7	Spezifikation	Bestell-Nr.
21,50	TTD-3F04-2150-MxP	30841846
21,70	TTD-3F04-2170-MxP	30841847
21,80	TTD-3F04-2180-MxP	30841973
22,00	TTD-3F04-2200-MxP	30841848
22,10	TTD-3F04-2210-MxP	30841975
22,20	TTD-3F04-2220-MxP	30841976
22,30	TTD-3F04-2230-MxP	30841977
22,40	TTD-3F04-2240-MxP	30841978
22,50	TTD-3F04-2250-MxP	30841849
22,60	TTD-3F04-2260-MxP	30841979
22,70	TTD-3F04-2270-MxP	30841850
23,00	TTD-3F04-2300-MxP	30841851
23,10	TTD-3F04-2310-MxP	30841982
23,30	TTD-3F04-2330-MxP	30841984
23,50	TTD-3F04-2350-MxP	30841852
23,70	TTD-3F04-2370-MxP	30841853
24,00	TTD-3F04-2400-MxP	30841854
24,40	TTD-3F04-2440-MxP	30841992
24,50	TTD-3F04-2450-MxP	30841855
24,70	TTD-3F04-2470-MxP	30841856
24,80	TTD-3F04-2480-MxP	30841994
25,00	TTD-3F04-2500-MxP	30841857
25,20	TTD-3F04-2520-MxP	30841997
25,30	TTD-3F04-2530-MxP	30841998
25,40	TTD-3F04-2540-MxP	30841999
25,50	TTD-3F04-2550-MxP	30841858
25,90	TTD-3F04-2590-MxP	30842002
26,00	TTD-3F04-2600-MxP	30841860
26,10	TTD-3F04-2610-MxP	30842003

d <sub>1</sub> von 26,20 bis 41,00		
d <sub>1</sub> m7	Spezifikation	Bestell-Nr.
26,20	TTD-3F04-2620-MxP	30842004
26,50	TTD-3F04-2650-MxP	30841861
26,70	TTD-3F04-2670-MxP	30841862
27,00	TTD-3F04-2700-MxP	30841863
27,50	TTD-3F04-2750-MxP	30841864
27,70	TTD-3F04-2770-MxP	30841865
27,80	TTD-3F04-2780-MxP	30842015
28,00	TTD-3F04-2800-MxP	30841866
28,20	TTD-3F04-2820-MxP	30842018
28,30	TTD-3F04-2830-MxP	30842019
28,50	TTD-3F04-2850-MxP	30841867
29,00	TTD-3F04-2900-MxP	30841869
30,00	TTD-3F04-3000-MxP	30841872
30,30	TTD-3F04-3030-MxP	30842033
30,50	TTD-3F04-3050-MxP	30841873
31,00	TTD-3F04-3100-MxP	30841875
31,50	TTD-3F04-3150-MxP	30841876
31,70	TTD-3F04-3170-MxP	30841877
32,00	TTD-3F04-3200-MxP	30841878
33,00	TTD-3F04-3300-MxP	30841880
34,00	TTD-3F04-3400-MxP	30841882
34,50	TTD-3F04-3450-MxP	30841883
35,00	TTD-3F04-3500-MxP	30841884
36,00	TTD-3F04-3600-MxP	30841886
37,00	TTD-3F04-3700-MxP	30841888
38,00	TTD-3F04-3800-MxP	30841890
39,00	TTD-3F04-3900-MxP	30841892
40,00	TTD-3F04-4000-MxP	30841894
41,00	TTD-3F04-4100-MxP	30841896

## Konfigurierbare Merkmale



**Durchmesser:**  
Durchmesser in Abstufungen  
von 0,01 mm frei wählbar



## Spezifikation:

TTD-3F04-[Durchmesser]-MxP

## Abmessungen konfigurierbare Baureihe

d <sub>1</sub> min.	d <sub>1</sub> max.
12,00	45,00

## Beispiel:

TTD-3F04-1401-MxP

Werkzeugdurchmesser d<sub>1</sub> = 14,01 mm



# Wechselbohrkopf TTD

Aus Vollhartmetall, innere Kühlmittelzufuhr  
Typ 02 - Inox

**Ausführung:**  
Bohrerdurchmesser: 12,00 - 45,00 mm  
Bohrungstoleranz: ≥ IT 9  
Beschichtung: MxF  
Schneidenanzahl: 2  
Anzahl Führungsfasen: 3  
Spitzenwinkel: 138°

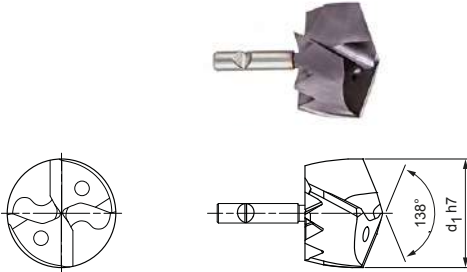

## Lagerhaltige Vorzugsbaureihe

d <sub>1</sub> von 12,00 bis 16,40		
d <sub>1</sub> h7	Spezifikation	Bestell-Nr.
12,00	TTD-3F02-1200-MxF	30841692
12,10	TTD-3F02-1210-MxF	30842582
12,20	TTD-3F02-1220-MxF	30842583
12,40	TTD-3F02-1240-MxF	30842585
12,50	TTD-3F02-1250-MxF	30841693
12,60	TTD-3F02-1260-MxF	30842586
12,70	TTD-3F02-1270-MxF	30841694
13,00	TTD-3F02-1300-MxF	30841695
13,10	TTD-3F02-1310-MxF	30842589
13,50	TTD-3F02-1350-MxF	30841696
13,80	TTD-3F02-1380-MxF	30842594
14,00	TTD-3F02-1400-MxF	30841698
14,10	TTD-3F02-1410-MxF	30842581
14,20	TTD-3F02-1420-MxF	30842596
14,30	TTD-3F02-1430-MxF	30842597
14,40	TTD-3F02-1440-MxF	30842598
14,50	TTD-3F02-1450-MxF	30841699
14,60	TTD-3F02-1460-MxF	30842599
14,70	TTD-3F02-1470-MxF	30841700
14,80	TTD-3F02-1480-MxF	30842600
15,00	TTD-3F02-1500-MxF	30841701
15,10	TTD-3F02-1510-MxF	30842602
15,30	TTD-3F02-1530-MxF	30842604
15,50	TTD-3F02-1550-MxF	30841702
15,60	TTD-3F02-1560-MxF	30842606
15,70	TTD-3F02-1570-MxF	30841675
15,80	TTD-3F02-1580-MxF	30842607
15,90	TTD-3F02-1590-MxF	30842608
16,00	TTD-3F02-1600-MxF	30841642
16,10	TTD-3F02-1610-MxF	30842609
16,20	TTD-3F02-1620-MxF	30842610
16,30	TTD-3F02-1630-MxF	30842611
16,40	TTD-3F02-1640-MxF	30842612

d <sub>1</sub> von 16,50 bis 21,00		
d <sub>1</sub> h7	Spezifikation	Bestell-Nr.
16,50	TTD-3F02-1650-MxF	30841643
16,60	TTD-3F02-1660-MxF	30842613
16,70	TTD-3F02-1670-MxF	30841676
16,80	TTD-3F02-1680-MxF	30842614
17,00	TTD-3F02-1700-MxF	30841644
17,50	TTD-3F02-1750-MxF	30841645
17,60	TTD-3F02-1760-MxF	30842620
17,70	TTD-3F02-1770-MxF	30841677
17,80	TTD-3F02-1780-MxF	30842621
18,00	TTD-3F02-1800-MxF	30841646
18,20	TTD-3F02-1820-MxF	30842624
18,30	TTD-3F02-1830-MxF	30842625
18,50	TTD-3F02-1850-MxF	30841647
18,60	TTD-3F02-1860-MxF	30842627
18,80	TTD-3F02-1880-MxF	30842628
18,90	TTD-3F02-1890-MxF	30842629
19,00	TTD-3F02-1900-MxF	30841648
19,10	TTD-3F02-1910-MxF	30842630
19,20	TTD-3F02-1920-MxF	30842631
19,30	TTD-3F02-1930-MxF	30842632
19,40	TTD-3F02-1940-MxF	30842633
19,50	TTD-3F02-1950-MxF	30841649
19,70	TTD-3F02-1970-MxF	30841679
19,80	TTD-3F02-1980-MxF	30842635
19,90	TTD-3F02-1990-MxF	30842636
20,00	TTD-3F02-2000-MxF	30841650
20,10	TTD-3F02-2010-MxF	30842637
20,20	TTD-3F02-2020-MxF	30842638
20,30	TTD-3F02-2030-MxF	30842639
20,40	TTD-3F02-2040-MxF	30842640
20,50	TTD-3F02-2050-MxF	30841651
20,70	TTD-3F02-2070-MxF	30841680
21,00	TTD-3F02-2100-MxF	30841652

## Wechselbohrkopf TTD aus Vollhartmetall, innere Kühlmittelzufuhr - Typ 02

d <sub>1</sub> von 21,20 bis 25,80		
d <sub>1</sub> h7	Spezifikation	Bestell-Nr.
21,20	TTD-3F02-2120-MxF	30842644
21,50	TTD-3F02-2150-MxF	30841653
21,70	TTD-3F02-2170-MxF	30841681
21,80	TTD-3F02-2180-MxF	30842648
22,00	TTD-3F02-2200-MxF	30841654
22,10	TTD-3F02-2210-MxF	30842650
22,40	TTD-3F02-2240-MxF	30842652
22,50	TTD-3F02-2250-MxF	30841655
22,60	TTD-3F02-2260-MxF	30842653
22,70	TTD-3F02-2270-MxF	30841682
22,80	TTD-3F02-2280-MxF	30842654
22,90	TTD-3F02-2290-MxF	30842655
23,00	TTD-3F02-2300-MxF	30841656
23,50	TTD-3F02-2350-MxF	30841657
23,70	TTD-3F02-2370-MxF	30841683
24,00	TTD-3F02-2400-MxF	30841658
24,20	TTD-3F02-2420-MxF	30842664
24,40	TTD-3F02-2440-MxF	30842665
24,50	TTD-3F02-2450-MxF	30841659
24,70	TTD-3F02-2470-MxF	30841684
24,80	TTD-3F02-2480-MxF	30842667
25,00	TTD-3F02-2500-MxF	30841660
25,20	TTD-3F02-2520-MxF	30841703
25,30	TTD-3F02-2530-MxF	30842670
25,40	TTD-3F02-2540-MxF	30842671
25,50	TTD-3F02-2550-MxF	30841661
25,70	TTD-3F02-2570-MxF	30841685
25,80	TTD-3F02-2580-MxF	30842673

d <sub>1</sub> von 26,00 bis 38,50		
d <sub>1</sub> h7	Spezifikation	Bestell-Nr.
26,00	TTD-3F02-2600-MxF	30841662
26,50	TTD-3F02-2650-MxF	30841663
26,80	TTD-3F02-2680-MxF	30842680
27,00	TTD-3F02-2700-MxF	30841664
27,10	TTD-3F02-2710-MxF	30842682
27,40	TTD-3F02-2740-MxF	30842685
27,50	TTD-3F02-2750-MxF	30841665
28,00	TTD-3F02-2800-MxF	30841666
28,10	TTD-3F02-2810-MxF	30842689
28,20	TTD-3F02-2820-MxF	30842690
28,50	TTD-3F02-2850-MxF	30841667
28,60	TTD-3F02-2860-MxF	30842693
28,70	TTD-3F02-2870-MxF	30841688
29,00	TTD-3F02-2900-MxF	30841668
29,50	TTD-3F02-2950-MxF	30841669
29,70	TTD-3F02-2970-MxF	30841689
29,80	TTD-3F02-2980-MxF	30842701
29,90	TTD-3F02-2990-MxF	30842702
30,00	TTD-3F02-3000-MxF	30841670
30,10	TTD-3F02-3010-MxF	30842703
30,30	TTD-3F02-3030-MxF	30842705
31,00	TTD-3F02-3100-MxF	30841672
31,30	TTD-3F02-3130-MxF	30842712
31,50	TTD-3F02-3150-MxF	30841673
31,80	TTD-3F02-3180-MxF	30842715
32,00	TTD-3F02-3200-MxF	30841674
38,50	TTD-3F02-3850-MxF	30841716

## Konfigurierbare Merkmale



**Durchmesser:**  
Durchmesser in Abstufungen  
von 0,01 mm frei wählbar



## Spezifikation:

TTD-3F02-[Durchmesser]-MxF

## Abmessungen konfigurierbare Baureihe

d <sub>1</sub> min.	d <sub>1</sub> max.
12,00	45,00

## Beispiel:

TTD-3F02-1401-MxF

Werkzeugdurchmesser d<sub>1</sub> = 14,01 mm

# Wechselbohrkopf TTD

Aus Vollhartmetall, innere Kühlmittelzufuhr  
Typ 05 - Iron

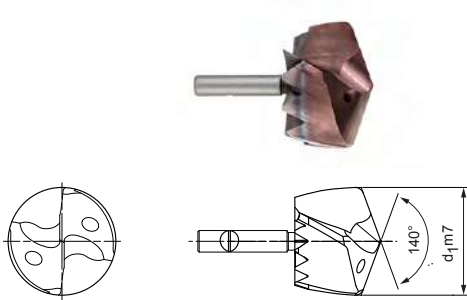

## Ausführung:

Bohrerdurchmesser: 12,00 - 45,00 mm  
Bohrungstoleranz:  $\geq IT 9$   
Beschichtung: MxM  
Schneidenanzahl: 2  
Anzahl Führungsfasen: 4  
Spitzenwinkel: 140°



## Lagerhaltige Vorzugsbaureihe

d <sub>1</sub> von 12,50 bis 20,80		
d <sub>1</sub> m7	Spezifikation	Bestell-Nr.
12,50	TTD-4F05-1250-MxM	30842050
12,70	TTD-4F05-1270-MxM	30842052
14,00	TTD-4F05-1400-MxM	30842065
14,50	TTD-4F05-1450-MxM	30842070
15,30	TTD-4F05-1530-MxM	30842078
15,70	TTD-4F05-1570-MxM	30842082
16,30	TTD-4F05-1630-MxM	30842088
16,50	TTD-4F05-1650-MxM	30842090
16,70	TTD-4F05-1670-MxM	30842092
16,80	TTD-4F05-1680-MxM	30842093
17,00	TTD-4F05-1700-MxM	30842095
17,10	TTD-4F05-1710-MxM	30842096
17,50	TTD-4F05-1750-MxM	30842100
18,00	TTD-4F05-1800-MxM	30842105
18,20	TTD-4F05-1820-MxM	30842107
18,50	TTD-4F05-1850-MxM	30842110
18,60	TTD-4F05-1860-MxM	30842111
18,80	TTD-4F05-1880-MxM	30842113
19,00	TTD-4F05-1900-MxM	30842115
19,70	TTD-4F05-1970-MxM	30842122
20,50	TTD-4F05-2050-MxM	30842130
20,70	TTD-4F05-2070-MxM	30842132
20,80	TTD-4F05-2080-MxM	30842133

d <sub>1</sub> von 21,00 bis 37,00		
d <sub>1</sub> m7	Spezifikation	Bestell-Nr.
21,00	TTD-4F05-2100-MxM	30842135
21,10	TTD-4F05-2110-MxM	30842136
21,50	TTD-4F05-2150-MxM	30842140
21,70	TTD-4F05-2170-MxM	30842142
22,00	TTD-4F05-2200-MxM	30842145
22,10	TTD-4F05-2210-MxM	30842146
22,30	TTD-4F05-2230-MxM	30842148
22,70	TTD-4F05-2270-MxM	30842152
23,00	TTD-4F05-2300-MxM	30842155
23,50	TTD-4F05-2350-MxM	30842160
24,00	TTD-4F05-2400-MxM	30842165
24,40	TTD-4F05-2440-MxM	30842169
24,80	TTD-4F05-2480-MxM	30842173
25,00	TTD-4F05-2500-MxM	30842175
25,80	TTD-4F05-2580-MxM	30842183
26,00	TTD-4F05-2600-MxM	30842185
27,00	TTD-4F05-2700-MxM	30842195
27,10	TTD-4F05-2710-MxM	30842196
28,00	TTD-4F05-2800-MxM	30842205
28,50	TTD-4F05-2850-MxM	30842210
30,00	TTD-4F05-3000-MxM	30842225
32,00	TTD-4F05-3200-MxM	30842245
37,00	TTD-4F05-3700-MxM	30842255

## Konfigurierbare Merkmale



### Durchmesser:

Durchmesser in Abstufungen  
von 0,01 mm frei wählbar



### Spezifikation:

TTD-4F05-[Durchmesser]-MxM

## Abmessungen konfigurierbare Baureihe

d <sub>1</sub> min.	d <sub>1</sub> max.
12,00	45,00

### Beispiel:

TTD-4F05-1401-MxM

Werkzeugdurchmesser d<sub>1</sub> = 14,01 mm

Maßangaben in mm.

Schnittwertempfehlung siehe Kapitelende.

Sonderausführungen und andere Beschichtungen auf Anfrage.

# Wechselbohrkopf TTD

Aus Vollhartmetall, innere Kühlmittelzufuhr  
Typ 03 - Alu

**Ausführung:**

Bohrerdurchmesser: 12,00 - 45,00 mm  
Bohrungstoleranz: ≥ IT 9  
Beschichtung: Mx11  
Schneidenanzahl: 2  
Anzahl Führungsfasen: 4  
Spitzenwinkel: 140°

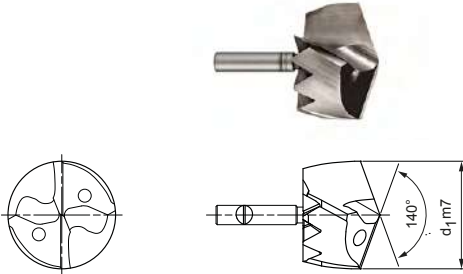

**Lagerhaltige Vorzugsbaureihe**

d <sub>1</sub> von 12,10 bis 21,00		
d <sub>1</sub> m7	Spezifikation	Bestell-Nr.
12,10	TTD-4F03-1210-MxA	30842719
12,50	TTD-4F03-1250-MxA	30841781
12,80	TTD-4F03-1280-MxA	30842724
13,00	TTD-4F03-1300-MxA	30841783
13,50	TTD-4F03-1350-MxA	30841784
14,00	TTD-4F03-1400-MxA	30841786
14,50	TTD-4F03-1450-MxA	30841787
14,70	TTD-4F03-1470-MxA	30841788
14,90	TTD-4F03-1490-MxA	30842740
15,00	TTD-4F03-1500-MxA	30841789
16,00	TTD-4F03-1600-MxA	30841730
16,10	TTD-4F03-1610-MxA	30842748
16,50	TTD-4F03-1650-MxA	30841731
17,00	TTD-4F03-1700-MxA	30841732
17,50	TTD-4F03-1750-MxA	30841733
18,00	TTD-4F03-1800-MxA	30841734
18,10	TTD-4F03-1810-MxA	30842718
18,20	TTD-4F03-1820-MxA	30842762
18,30	TTD-4F03-1830-MxA	30842763
18,50	TTD-4F03-1850-MxA	30841735
18,60	TTD-4F03-1860-MxA	30842765
18,70	TTD-4F03-1870-MxA	30841766
19,00	TTD-4F03-1900-MxA	30841736
19,50	TTD-4F03-1950-MxA	30841737
19,60	TTD-4F03-1960-MxA	30842772
20,00	TTD-4F03-2000-MxA	30841738
20,30	TTD-4F03-2030-MxA	30842717
20,50	TTD-4F03-2050-MxA	30841739
21,00	TTD-4F03-2100-MxA	30841740

d <sub>1</sub> von 21,50 bis 43,00		
d <sub>1</sub> m7	Spezifikation	Bestell-Nr.
21,50	TTD-4F03-2150-MxA	30841741
22,00	TTD-4F03-2200-MxA	30841742
22,50	TTD-4F03-2250-MxA	30841743
22,60	TTD-4F03-2260-MxA	30842792
23,00	TTD-4F03-2300-MxA	30841744
23,50	TTD-4F03-2350-MxA	30841745
23,90	TTD-4F03-2390-MxA	30842801
24,00	TTD-4F03-2400-MxA	30841746
24,10	TTD-4F03-2410-MxA	30842802
24,40	TTD-4F03-2440-MxA	30842805
24,50	TTD-4F03-2450-MxA	30841747
25,00	TTD-4F03-2500-MxA	30841748
25,10	TTD-4F03-2510-MxA	30842809
25,20	TTD-4F03-2520-MxA	30842810
25,50	TTD-4F03-2550-MxA	30841749
26,00	TTD-4F03-2600-MxA	30841750
26,40	TTD-4F03-2640-MxA	30842819
27,00	TTD-4F03-2700-MxA	30841752
27,50	TTD-4F03-2750-MxA	30841753
28,00	TTD-4F03-2800-MxA	30841754
28,30	TTD-4F03-2830-MxA	30842832
28,40	TTD-4F03-2840-MxA	30842833
29,50	TTD-4F03-2950-MxA	30841757
31,00	TTD-4F03-3100-MxA	30841760
31,20	TTD-4F03-3120-MxA	30842853
32,00	TTD-4F03-3200-MxA	30841762
35,00	TTD-4F03-3500-MxA	30841796
43,00	TTD-4F03-4300-MxA	30841812

**Konfigurierbare Merkmale**



**Durchmesser:**  
Durchmesser in Abstufungen  
von 0,01 mm frei wählbar



**Spezifikation:**

TTD-4F03-[Durchmesser]-MxA

**Abmessungen konfigurierbare Baureihe**

d <sub>1</sub> min.	d <sub>1</sub> max.
12.00	45.00

**Beispiel:**

TTD-4F03-1401-MxA

Werkzeugdurchmesser d<sub>1</sub> = 14.01 mm

Maßangaben in mm.

Schnittwertempfehlung siehe Kapitelende.

Sonderausführungen und andere Beschichtungen auf Anfrage.

# Wechselkopfhalter TTS

Mit Frontspannsystem für Wechselkopfborener TTD  
TTS100 (1xD), innere Kühlmittelzufuhr

## Ausführung:

Für Bohrerdurchmesser: 12,00 - 45,49 mm  
Wechselsystem: System-Frontspannung  
Kopfwechsel auf der Maschine möglich

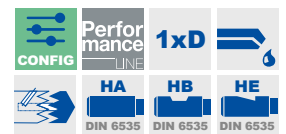
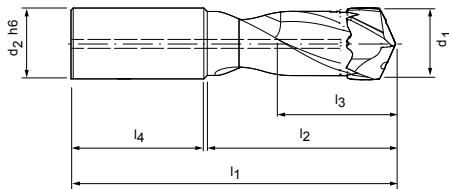

## Lagerhaltige Vorzugsbaureihe

Baumaße							Schaffform HB	
d <sub>1</sub>	Trennstelle	d <sub>2</sub> h6	l <sub>1</sub>	l <sub>2</sub>	l <sub>3</sub>	l <sub>4</sub>	Spezifikation	Bestell-Nr.
12,00-12,49	TTS12-S	14	81	29	13	45	TTS100-12-DR1-1200-14-HB	30324304
12,50-12,99	TTS12-S	14	81	29	13	45	TTS100-12-DR1-1250-14-HB	30324305
13,00-13,49	TTS12-S	14	81	31	14	45	TTS100-12-DR1-1300-14-HB	30324306
13,50-13,99	TTS12-S	16	86	32	14	48	TTS100-12-DR1-1350-16-HB	30324307
14,00-14,49	TTS12-S	16	86	33	15	48	TTS100-12-DR1-1400-16-HB	30324308
14,50-14,99	TTS12-S	16	91	34	15	48	TTS100-12-DR1-1450-16-HB	30324309
15,00-15,49	TTS12-S	16	91	36	16	48	TTS100-12-DR1-1500-16-HB	30324310
15,50-16,49	TTS12-S	18	92	38	17	48	TTS100-12-DR1-1550-18-HB	30324311
16,50-17,49	TTS12-S	18	94	40	18	48	TTS100-12-DR1-1650-18-HB	30324312
17,50-18,49	TTS12-S	18	99	43	19	48	TTS100-12-DR1-1750-18-HB	30324313
18,50-19,49	TTS12-S	20	99	45	20	50	TTS100-12-DR1-1850-20-HB	30324314
19,50-20,49	TTS12-S	20	104	47	21	50	TTS100-12-DR1-1950-20-HB	30324316
20,50-21,49	TTS12-S	25	111	49	22	56	TTS100-12-DR1-2050-25-HB	30324317
21,50-22,49	TTS12-S	25	116	52	23	56	TTS100-12-DR1-2150-25-HB	30324318
22,50-23,49	TTS12-S	25	116	54	24	56	TTS100-12-DR1-2250-25-HB	30324319
23,50-24,49	TTS12-S	25	121	56	25	56	TTS100-12-DR1-2350-25-HB	30324320
24,50-25,49	TTS18-S	25	123	59	26	56	TTS100-18-DR1-2450-25-HB	30324321
25,50-26,49	TTS18-S	25	123	61	27	56	TTS100-18-DR1-2550-25-HB	30324322
26,50-27,49	TTS18-S	25	128	63	28	56	TTS100-18-DR1-2650-25-HB	30324323
27,50-28,49	TTS18-S	25	128	66	29	56	TTS100-18-DR1-2750-25-HB	30324325
28,50-29,49	TTS18-S	32	134	68	30	60	TTS100-18-DR1-2850-32-HB	30324327
29,50-30,49	TTS18-S	32	139	70	31	60	TTS100-18-DR1-2950-32-HB	30324328
30,50-31,49	TTS18-S	32	139	75	32	60	TTS100-18-DR1-3050-32-HB	30324329
31,50-32,49	TTS18-S	32	139	75	33	60	TTS100-18-DR1-3150-32-HB	30324330
32,50-33,49	TTS18-S	32	150	78	34	60	TTS100-18-DR1-3250-32-HB	30374587
33,50-34,49	TTS18-S	32	150	79	35	60	TTS100-18-DR1-3350-32-HB	30374590
34,50-35,49	TTS18-S	32	150	82	36	60	TTS100-18-DR1-3450-32-HB	30374593
35,50-37,49	TTS18-S	40	162	86	38	70	TTS100-18-DR1-3550-40-HB	30535302
37,50-39,49	TTS18-S	40	167	71	40	70	TTS100-18-DR1-3750-40-HB	30535303
39,50-41,49	TTS18-S	40	177	95	42	70	TTS100-18-DR1-3950-40-HB	30535305
41,50-43,49	TTS18-S	40	180	100	44	70	TTS100-18-DR1-4150-40-HB	30535307
43,50-45,49	TTS18-S	40	185	105	46	70	TTS100-18-DR1-4350-40-HB	30535312

Fortsetzung auf nächster Seite.

## Konfigurierbare Merkmale



**Schaftform:**  
Schaftform: HA | HE

**Spezifikation:**

TTS100-18-DR1-4150-40-[Schaftform]

**Beispiel:**TTS100-18-DR1-4150-40-**HE**

Schaftform HE

# Wechselkopfhalter TTS

Mit Frontspannsystem für Wechselkopfbohrer TTD  
TTS100 (3xD), innere Kühlmittelzufuhr

## Ausführung:

Für Bohrer Durchmesser: 12,00 - 45,49 mm  
Wechselsystem: System-Frontspannung  
Kopfwechsel auf der Maschine möglich

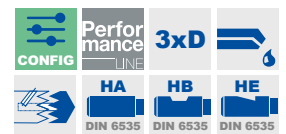
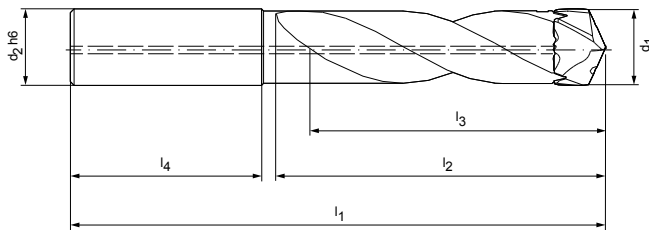

## Lagerhaltige Vorzugsbaureihe

Baumaße							Schaffform HB	
d <sub>1</sub>	Trennstelle	d <sub>2</sub> h6	l <sub>1</sub>	l <sub>2</sub>	l <sub>3</sub>	l <sub>4</sub>	Spezifikation	Bestell-Nr.
12,00-12,49	TTS12-S	14	100	53	38	45	TTS100-12-DR3-1200-14-HB	30232785
12,50-12,99	TTS12-S	14	105	55	39	45	TTS100-12-DR3-1250-14-HB	30232787
13,00-13,49	TTS12-S	14	105	57	41	45	TTS100-12-DR3-1300-14-HB	30232789
13,50-13,99	TTS12-S	16	110	59	42	48	TTS100-12-DR3-1350-16-HB	30232790
14,00-14,49	TTS12-S	16	115	61	44	48	TTS100-12-DR3-1400-16-HB	30232792
14,50-14,99	TTS12-S	16	115	63	45	48	TTS100-12-DR3-1450-16-HB	30232793
15,00-15,49	TTS12-S	16	115	65	47	48	TTS100-12-DR3-1500-16-HB	30232794
15,50-16,49	TTS12-S	18	120	70	50	48	TTS100-12-DR3-1550-18-HB	30191496
16,50-17,49	TTS12-S	18	125	74	53	48	TTS100-12-DR3-1650-18-HB	30191497
17,50-18,49	TTS12-S	18	130	78	56	48	TTS100-12-DR3-1750-18-HB	30191498
18,50-19,49	TTS12-S	20	135	82	59	50	TTS100-12-DR3-1850-20-HB	30191499
19,50-20,49	TTS12-S	20	140	87	62	50	TTS100-12-DR3-1950-20-HB	30191500
20,50-21,49	TTS12-S	25	150	91	65	56	TTS100-12-DR3-2050-25-HB	30191501
21,50-22,49	TTS12-S	25	155	95	68	56	TTS100-12-DR3-2150-25-HB	30191502
22,50-23,49	TTS12-S	25	160	99	71	56	TTS100-12-DR3-2250-25-HB	30191503
23,50-24,49	TTS12-S	25	165	103	74	56	TTS100-12-DR3-2350-25-HB	30191504
24,50-25,49	TTS18-S	25	165	108	77	56	TTS100-18-DR3-2450-25-HB	30191505
25,50-26,49	TTS18-S	25	175	112	80	56	TTS100-18-DR3-2550-25-HB	30191507
26,50-27,49	TTS18-S	25	175	116	83	56	TTS100-18-DR3-2650-25-HB	30191508
27,50-28,49	TTS18-S	25	180	120	86	56	TTS100-18-DR3-2750-25-HB	30191509
28,50-29,49	TTS18-S	32	190	124	89	60	TTS100-18-DR3-2850-32-HB	30191510
29,50-30,49	TTS18-S	32	195	129	92	60	TTS100-18-DR3-2950-32-HB	30191511
30,50-31,49	TTS18-S	32	195	133	95	60	TTS100-18-DR3-3050-32-HB	30191512
31,50-32,49	TTS18-S	32	200	137	98	60	TTS100-18-DR3-3150-32-HB	30191513
32,50-33,49	TTS18-S	32	210	144	101	60	TTS100-18-DR3-3250-32-HB	30322289
33,50-34,49	TTS18-S	32	215	148	104	60	TTS100-18-DR3-3350-32-HB	30322290
34,50-35,49	TTS18-S	32	220	153	107	60	TTS100-18-DR3-3450-32-HB	30322291
35,50-37,49	TTS18-S	40	237	161	113	70	TTS100-18-DR3-3550-40-HB	30535313
37,50-39,49	TTS18-S	40	247	170	119	70	TTS100-18-DR3-3750-40-HB	30535316
39,50-41,49	TTS18-S	40	257	178	125	70	TTS100-18-DR3-3950-40-HB	30535318
41,50-43,49	TTS18-S	40	265	187	131	70	TTS100-18-DR3-4150-40-HB	30535320
43,50-45,49	TTS18-S	40	275	196	137	70	TTS100-18-DR3-4350-40-HB	30535321

Fortsetzung auf nächster Seite.

## Konfigurierbare Merkmale



**Schaftform:**  
Schaftform: HA | HE

**Spezifikation:**

TTS100-18-DR5-4150-40-[Schaftform]

**Beispiel:**

TTS100-18-DR5-4150-40-HE

Schaftform HE



# Wechselkopfhalter TTS

Mit Frontspannsystem für Wechselkopfbohrer TTD  
TTS100 (5xD), innere Kühlmittelzufuhr

## Ausführung:

Für Bohrerdurchmesser: 12,00 - 45,49 mm  
Wechselsystem: System-Frontspannung  
Kopfwechsel auf der Maschine möglich

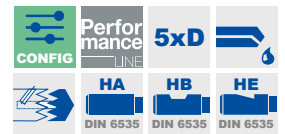
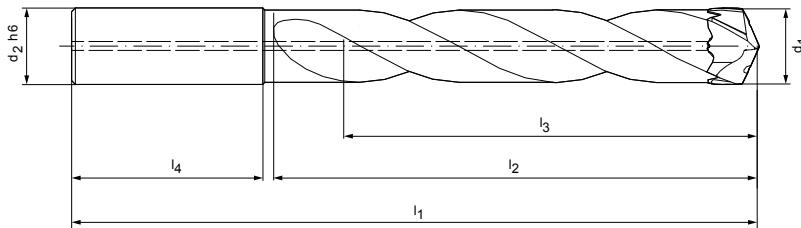

## Lagerhaltige Vorzugsbaureihe

Baumaße							Schaffform HB	
d <sub>1</sub>	Trennstelle	d <sub>2</sub> h6	l <sub>1</sub>	l <sub>2</sub>	l <sub>3</sub>	l <sub>4</sub>	Spezifikation	Bestell-Nr.
12,00-12,49	TTS12-S	14	125	78	63	45	TTS100-12-DR5-1200-14-HB	30232796
12,50-12,99	TTS12-S	14	130	81	65	45	TTS100-12-DR5-1250-14-HB	30232798
13,00-13,49	TTS12-S	14	130	84	68	45	TTS100-12-DR5-1300-14-HB	30232799
13,50-13,99	TTS12-S	16	140	88	70	48	TTS100-12-DR5-1350-16-HB	30232800
14,00-14,49	TTS12-S	16	140	90	73	48	TTS100-12-DR5-1400-16-HB	30232801
14,50-14,99	TTS12-S	16	145	94	75	48	TTS100-12-DR5-1450-16-HB	30232802
15,00-15,49	TTS12-S	16	145	96	78	48	TTS100-12-DR5-1500-16-HB	30232803
15,50-16,49	TTS12-S	18	155	103	83	48	TTS100-12-DR5-1550-18-HB	30191514
16,50-17,49	TTS12-S	18	160	109	88	48	TTS100-12-DR5-1650-18-HB	30191515
17,50-18,49	TTS12-S	18	165	115	93	48	TTS100-12-DR5-1750-18-HB	30191516
18,50-19,49	TTS12-S	20	175	121	98	50	TTS100-12-DR5-1850-20-HB	30191517
19,50-20,49	TTS12-S	20	180	128	103	50	TTS100-12-DR5-1950-20-HB	30191518
20,50-21,49	TTS12-S	25	195	134	108	56	TTS100-12-DR5-2050-25-HB	30191519
21,50-22,49	TTS12-S	25	200	140	113	56	TTS100-12-DR5-2150-25-HB	30191520
22,50-23,49	TTS12-S	25	205	146	118	56	TTS100-12-DR5-2250-25-HB	30191521
23,50-24,49	TTS12-S	25	210	152	123	56	TTS100-12-DR5-2350-25-HB	30191522
24,50-25,49	TTS18-S	25	220	159	128	56	TTS100-18-DR5-2450-25-HB	30191523
25,50-26,49	TTS18-S	25	225	165	133	56	TTS100-18-DR5-2550-25-HB	30191525
26,50-27,49	TTS18-S	25	230	171	138	56	TTS100-18-DR5-2650-25-HB	30191526
27,50-28,49	TTS18-S	25	240	177	143	56	TTS100-18-DR5-2750-25-HB	30191527
28,50-29,49	TTS18-S	32	250	183	148	60	TTS100-18-DR5-2850-32-HB	30191528
29,50-30,49	TTS18-S	32	255	190	153	60	TTS100-18-DR5-2950-32-HB	30191529
30,50-31,49	TTS18-S	32	260	196	158	60	TTS100-18-DR5-3050-32-HB	30191530
31,50-32,49	TTS18-S	32	265	202	163	60	TTS100-18-DR5-3150-32-HB	30191531
32,50-33,49	TTS18-S	32	275	210	168	60	TTS100-18-DR5-3250-32-HB	30322313
33,50-34,49	TTS18-S	32	285	217	173	60	TTS100-18-DR5-3350-32-HB	30322314
34,50-35,49	TTS18-S	32	290	224	178	60	TTS100-18-DR5-3450-32-HB	30322315
*35,50-37,49	TTS18-S	40	312	236	188	70	TTS100-18-DR5-3550-40-HB	30535324
*37,50-39,49	TTS18-S	40	327	249	198	70	TTS100-18-DR5-3750-40-HB	30534860
*39,50-41,49	TTS18-S	40	337	261	208	70	TTS100-18-DR5-3950-40-HB	30535326
*41,50-43,49	TTS18-S	40	350	274	218	70	TTS100-18-DR5-4150-40-HB	30535327
*43,50-45,49	TTS18-S	40	365	287	228	70	TTS100-18-DR5-4350-40-HB	30535328

Fortsetzung auf nächster Seite.

**Konfigurierbare Merkmale**

**Schaftform:**  
Schaftform: HA | HE

**Spezifikation:**

TTS100-18-DR5-4150-40-**[Schaftform]**

**Beispiel:**

TTS100-18-DR5-4150-40-**HE**

Schaftform HE

# Wechselkopfhalter TTS

Mit Frontspannsystem für Wechselkopfbohrer TTD  
TTS100 (8xD), innere Kühlmittelzufuhr

## Ausführung:

Für Bohrerdurchmesser: 12,00 - 45,49 mm  
Wechselsystem: System-Frontspannung  
Kopfwechsel auf der  
Maschine möglich

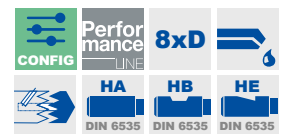
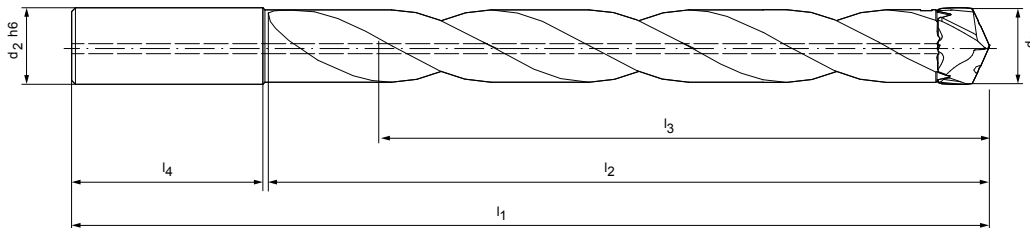

## Lagerhaltige Vorzugsbaureihe

Baumaße							Schaffform HB	
d <sub>1</sub>	Trennstelle	d <sub>2</sub> h6	l <sub>1</sub>	l <sub>2</sub>	l <sub>3</sub>	l <sub>4</sub>	Spezifikation	Bestell-Nr.
15,50-16,49	TTS12-S	18	205	152	132	48	TTS100-12-DR8-1550-18-HB	30191532
16,50-17,49	TTS12-S	18	215	161	140	48	TTS100-12-DR8-1650-18-HB	30191533
17,50-18,49	TTS12-S	18	220	171	148	48	TTS100-12-DR8-1750-18-HB	30191534
18,50-19,49	TTS12-S	20	235	180	156	50	TTS100-12-DR8-1850-20-HB	30191535
19,50-20,49	TTS12-S	20	240	189	164	50	TTS100-12-DR8-1950-20-HB	30191536
20,50-21,49	TTS12-S	25	260	198	172	56	TTS100-12-DR8-2050-25-HB	30191537
21,50-22,49	TTS12-S	25	270	207	180	56	TTS100-12-DR8-2150-25-HB	30191538
22,50-23,49	TTS12-S	25	275	217	188	56	TTS100-12-DR8-2250-25-HB	30191539
23,50-24,49	TTS12-S	25	285	226	196	56	TTS100-12-DR8-2350-25-HB	30191540
24,50-25,49	TTS18-S	25	295	235	204	56	TTS100-18-DR8-2450-25-HB	30191541
25,50-26,49	TTS18-S	25	305	244	212	56	TTS100-18-DR8-2550-25-HB	30191543
26,50-27,49	TTS18-S	25	315	253	220	56	TTS100-18-DR8-2650-25-HB	30191544
27,50-28,49	TTS18-S	25	325	263	228	56	TTS100-18-DR8-2750-25-HB	30191545
28,50-29,49	TTS18-S	32	340	272	236	60	TTS100-18-DR8-2850-32-HB	30191546
29,50-30,49	TTS18-S	32	345	281	244	60	TTS100-18-DR8-2950-32-HB	30191547
30,50-31,49	TTS18-S	32	355	290	252	60	TTS100-18-DR8-3050-32-HB	30191548
31,50-32,49	TTS18-S	32	360	299	260	60	TTS100-18-DR8-3150-32-HB	30191549
32,50 - 33,49	TTS18-S	32	375	275	268	60	TTS100-18-DR8-3250-32-HB	30809129
33,50 - 34,49	TTS18-S	32	385	317	276	60	TTS100-18-DR8-3350-32-HB	30809654
34,50 - 35,49	TTS18-S	32	395	329	284	60	TTS100-18-DR8-3450-32-HB	30809664
35,50 - 37,49	TTS18-S	32	402	336	300	60	TTS100-18-DR8-3550-32-HB	30812380
35,50 - 37,49	TTS18-S	40	412	336	300	70	TTS100-18-DR8-3550-40-HB	30809673
37,50 - 39,49	TTS18-S	32	421	353	316	60	TTS100-18-DR8-3750-32-HB	30812379
37,50 - 39,49	TTS18-S	40	431	353	316	70	TTS100-18-DR8-3750-40-HB	30809961
39,50 - 41,49	TTS18-S	32	440	374	332	70	TTS100-18-DR8-3950-32-HB	30812376
39,50 - 41,49	TTS18-S	40	450	374	332	70	TTS100-18-DR8-3950-40-HB	30809964
41,50 - 43,49	TTS18-S	40	470	394	348	70	TTS100-18-DR8-4150-40-HB	30809976
43,50 - 45,49	TTS18-S	40	500	422	364	70	TTS100-18-DR8-4350-40-HB	30809158

Fortsetzung auf nächster Seite.

**Konfigurierbare Merkmale**

**Schaftform:**  
Schaftform: HA | HE

**Spezifikation:**

TTS100-18-DR8-4150-40-**[Schaftform]**

**Beispiel:**

TTS100-18-DR8-4150-40-**HE**

Schaftform HE

# Wechselkopfhalter TTS

Mit Frontspannsystem für Wechselkopfbohrer TTD  
TTS100 (12xD), innere Kühlmittelzufuhr

**Ausführung:**

Für Bohrerdurchmesser: 12,00 - 32,49 mm  
Wechselsystem: System-Frontspannung  
Kopfwechsel auf der Maschine möglich

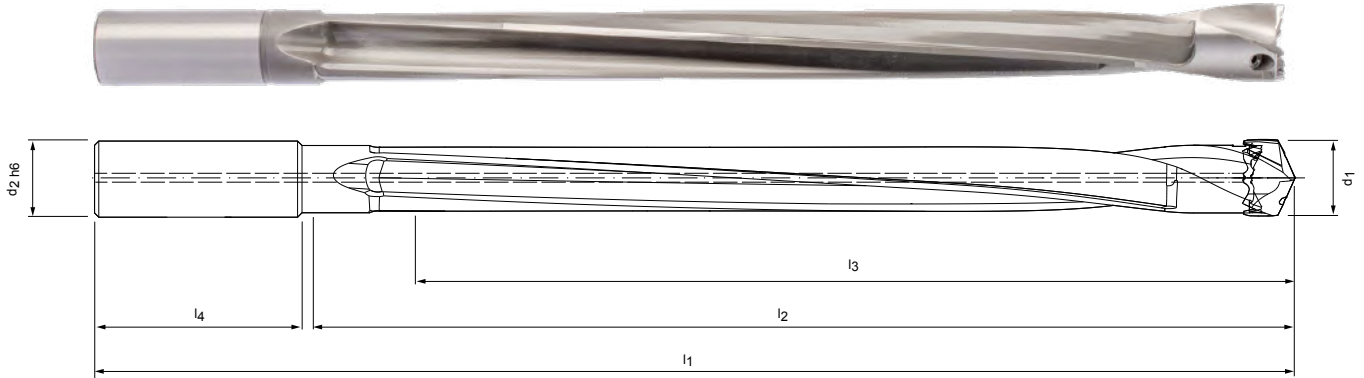

**Lagerhaltige Vorzugsbaureihe**

		Baumaße					Schaftform HB	
d <sub>1</sub>	Trennstelle	d <sub>2</sub> h6	l <sub>1</sub>	l <sub>2</sub>	l <sub>3</sub>	l <sub>4</sub>	Spezifikation	Bestell-Nr.
12,00-12,49	TTS12-S	14	210	162	150	45	TTS100-12-DR12-1200-14-HB	30327798
12,50-12,99	TTS12-S	14	216	168	156	45	TTS100-12-DR12-1250-14-HB	30327802
13,00-13,49	TTS12-S	14	223	175	162	45	TTS100-12-DR12-1300-14-HB	30327805
13,50-13,99	TTS12-S	16	235	182	168	48	TTS100-12-DR12-1350-16-HB	30327808
14,00-14,49	TTS12-S	16	242	189	174	48	TTS100-12-DR12-1400-16-HB	30327811
14,50-14,99	TTS12-S	16	248	195	180	48	TTS100-12-DR12-1450-16-HB	30327814
15,00-15,49	TTS12-S	16	255	202	186	48	TTS100-12-DR12-1500-16-HB	30327817
15,50-16,49	TTS12-S	18	262	209	198	48	TTS100-12-DR12-1550-18-HB	30327820
16,50-17,49	TTS12-S	18	275	222	210	48	TTS100-12-DR12-1650-18-HB	30327824
17,50-18,49	TTS12-S	18	289	236	222	48	TTS100-12-DR12-1750-18-HB	30327828
18,50-19,49	TTS12-S	20	304	249	234	50	TTS100-12-DR12-1850-20-HB	30327833
19,50-20,49	TTS12-S	20	318	263	246	50	TTS100-12-DR12-1950-20-HB	30255588
20,50-21,49	TTS12-S	25	337	276	258	56	TTS100-12-DR12-2050-25-HB	30327844
21,50-22,49	TTS12-S	25	351	290	270	56	TTS100-12-DR12-2150-25-HB	30327847
22,50-23,49	TTS12-S	25	364	303	282	56	TTS100-12-DR12-2250-25-HB	30327851
23,50-24,49	TTS12-S	25	378	317	294	56	TTS100-12-DR12-2350-25-HB	30327854
24,50-25,49	TTS18-S	25	391	330	306	56	TTS100-18-DR12-2450-25-HB	30327859
25,50-26,49	TTS18-S	25	405	344	318	56	TTS100-18-DR12-2550-25-HB	30327863
26,50-27,49	TTS18-S	25	418	357	330	56	TTS100-18-DR12-2650-25-HB	30327866
27,50-28,49	TTS18-S	25	432	371	342	56	TTS100-18-DR12-2750-25-HB	30327870
28,50-29,49	TTS18-S	32	449	384	354	60	TTS100-18-DR12-2850-32-HB	30327873
29,50-30,49	TTS18-S	32	463	398	366	60	TTS100-18-DR12-2950-32-HB	30327876
30,50-31,49	TTS18-S	32	476	411	378	60	TTS100-18-DR12-3050-32-HB	30327879
31,50-32,49	TTS18-S	32	490	425	390	60	TTS100-18-DR12-3150-32-HB	30327883

**Konfigurierbare Merkmale**

**Schaftform:**  
Schaftform: HA | HE

**Spezifikation:**  
TTS100-18-DR12-2850-32-[Schaftform]

**Beispiel:**

TTS100-18-DR12-2850-32-HE

Schaftform HE

Maßangaben in mm.

Beachten Sie die Handhabungshinweise für den Wechselkopfbohrer TTD (12xD) auf Seite 000. Sonderausführungen auf Anfrage.

## Ersatzteile

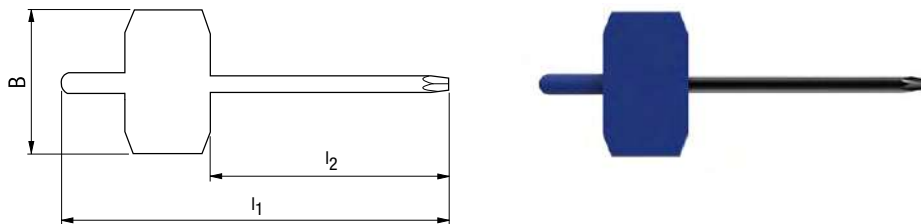

## Sechskant-Schraubendreher

Haltertyp	sw	l <sub>1</sub>	l <sub>2</sub>	B	Bestell-Nr.
TS100-12-DRx-1200-14-HB	1,3	95	60	38	10004355
TS100-12-DRx-1250-14-HB	1,3	95	60	38	10004355
TS100-12-DRx-1300-14-HB	1,3	95	60	38	10004355
TS100-12-DRx-1350-16-HB	1,5	95	60	38	10098108
TS100-12-DRx-1400-16-HB	1,5	95	60	38	10098108
TS100-12-DRx-1450-16-HB	1,5	95	60	38	10098108
TS100-12-DRx-1500-16-HB	1,5	95	60	38	10098108
TS100-12-DRx-1550-18-HB	1,5	95	60	38	10098108
TS100-12-DRx-1650-18-HB	2	95	60	38	10098109
TS100-12-DRx-1750-18-HB	2	95	60	38	10098109
TS100-12-DRx-1850-20-HB	2	95	60	38	10098109
TS100-12-DRx-1950-20-HB	2	95	60	38	10098109
TS100-12-DRx-2050-25-HB	2	95	60	38	10098109
TS100-12-DRx-2150-25-HB	2	95	60	38	10098109
TS100-12-DRx-2250-25-HB	2	95	60	38	10098109
TS100-12-DRx-2350-25-HB	2	95	60	38	10098109
TS100-18-DRx-2450-25-HB	2,5	95	60	38	10098110
TS100-18-DRx-2550-25-HB	2,5	95	60	38	10098110
TS100-18-DRx-2650-25-HB	2,5	95	60	38	10098110
TS100-18-DRx-2750-25-HB	2,5	95	60	38	10098110
TS100-18-DRx-2850-32-HB	2,5	95	60	38	10098110
TS100-18-DRx-2950-32-HB	2,5	95	60	38	10098110
TS100-18-DRx-3050-32-HB	2,5	95	60	38	10098110
TS100-18-DRx-3150-32-HB	2,5	95	60	38	10098110
TS100-18-DRx-3250-32-HB	3	100	60	38	10006234
TS100-18-DRx-3350-32-HB	3	100	60	38	10006234
TS100-18-DRx-3450-32-HB	3	100	60	38	10006234
TS100-18-DRx-3550-40-HB	3	100	60	38	10006234
TS100-18-DRx-3750-40-HB	3	100	60	38	10006234
TS100-18-DRx-3950-40-HB	3	100	60	38	10006234
TS100-18-DRx-4150-40-HB	4	100	60	38	10006235
TS100-18-DRx-4350-40-HB	4	100	60	38	10006235

# Gewindestift mit Spezialbeschichtung

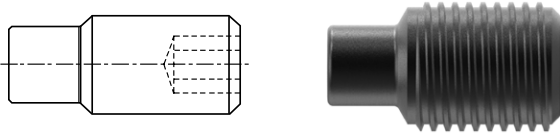

Haltertyp	Gewindestift	Anzugsdrehmoment [Nm]	Bestell-Nr.
TS100-12-DRx-1200-14-HB	M2,5x5	1,0	30259117
TS100-12-DRx-1250-14-HB	M2,5x6	1,0	30259118
TS100-12-DRx-1300-14-HB	M2,5x6	1,0	30259118
TS100-12-DRx-1350-16-HB	M3x6	1,3	30259119
TS100-12-DRx-1400-16-HB	M3x6	1,3	30259119
TS100-12-DRx-1450-16-HB	M3x7	1,3	30193231
TS100-12-DRx-1500-16-HB	M3x7	1,3	30193231
TS100-12-DRx-1550-18-HB	M3x7	1,3	30193231
TS100-12-DRx-1650-18-HB	M4x0,5x7,5	3,5	30193232
TS100-12-DRx-1750-18-HB	M4x0,5x7,5	3,5	30193232
TS100-12-DRx-1850-20-HB	M4x0,5x7,5	3,5	30193232
TS100-12-DRx-1950-20-HB	M4x0,5x7,5	3,5	30193232
TS100-12-DRx-2050-25-HB	M4x0,5x10	3,5	30193233
TS100-12-DRx-2150-25-HB	M4x0,5x10	3,5	30193233
TS100-12-DRx-2250-25-HB	M4x0,5x10	3,5	30193233
TS100-12-DRx-2350-25-HB	M4x0,5x10	3,5	30193233
TS100-18-DRx-2450-25-HB	M5x0,5x11	4,0	30193234
TS100-18-DRx-2550-25-HB	M5x0,5x11	4,0	30193234
TS100-18-DRx-2650-25-HB	M5x0,5x11	4,0	30193234
TS100-18-DRx-2750-25-HB	M5x0,5x11	4,0	30193234
TS100-18-DRx-2850-32-HB	M5x0,5x14	4,0	30193235
TS100-18-DRx-2950-32-HB	M5x0,5x14	4,0	30193235
TS100-18-DRx-3050-32-HB	M5x0,5x14	4,0	30193235
TS100-18-DRx-3150-32-HB	M5x0,5x14	4,0	30193235
TS100-18-DRx-3250-32-HB	M6x0,5x16	6,0	30320812
TS100-18-DRx-3350-32-HB	M6x0,5x16	6,0	30320812
TS100-18-DRx-3450-32-HB	M6x0,5x16	6,0	30320812
TS100-18-DRx-3550-40-HB	M6x0,5x18	6,0	30320811
TS100-18-DRx-3750-40-HB	M6x0,5x18	6,0	30320811
TS100-18-DRx-3950-40-HB	M6x0,5x20	6,0	30320810
TS100-18-DRx-4150-40-HB	M8x1x20	10,0	30320806
TS100-18-DRx-4350-40-HB	M8x1x20	10,0	30320806

# Schnittwertempfehlung für Wechselkopfbohrer TTD

Vorschub und Schnittgeschwindigkeit

## Typ 01P - Uni-Plus

MZG*	Werkstoff	Festigkeit/Härte [N/mm <sup>2</sup> ] [HRC]
P	P1.1 Bau-, Automaten-, Einsatz- und Vergütungsstähle, unlegiert	< 700
	P1.2 Bau-, Automaten-, Einsatz- und Vergütungsstähle, unlegiert	< 1.200
	P2.1 Nitrier-, Einsatz- und Vergütungsstähle, legiert	< 900
	P2.2 Nitrier-, Einsatz- und Vergütungsstähle, legiert	< 1.400
	P3.1 Werkzeug-, Wälzlager-, Feder- und Schnellarbeitsstähle**	< 800
	P3.2 Werkzeug-, Wälzlager-, Feder- und Schnellarbeitsstähle**	< 1.000
	P3.3 Werkzeug-, Wälzlager-, Feder- und Schnellarbeitsstähle**	< 1.500
	P5.1 Stahlguss	
	K	K1.1 Gusseisen mit Lamellengraphit (Grauguss), GJL
K2.1 Gusseisen mit Kugelgraphit, GJS		< 500
K2.2 Gusseisen mit Kugelgraphit, GJS		≤ 800
K2.3 Gusseisen mit Kugelgraphit, GJS		> 800
K3.1 Gusseisen mit Vermiculargraphit, GJV; Temperguss, GJM		< 500
K3.2 Gusseisen mit Vermiculargraphit, GJV; Temperguss, GJM		> 500

## Typ 04 - Steel

MZG*	Werkstoff	Festigkeit/Härte [N/mm <sup>2</sup> ] [HRC]	
P	P1.1 Bau-, Automaten-, Einsatz- und Vergütungsstähle, unlegiert	< 700	
	P1.2 Bau-, Automaten-, Einsatz- und Vergütungsstähle, unlegiert	< 1.200	
	P2.1 Nitrier-, Einsatz- und Vergütungsstähle, legiert	< 900	
	P2.2 Nitrier-, Einsatz- und Vergütungsstähle, legiert	< 1.400	
	P3.1 Werkzeug-, Wälzlager-, Feder- und Schnellarbeitsstähle**	< 800	
	P3.2 Werkzeug-, Wälzlager-, Feder- und Schnellarbeitsstähle**	< 1.000	
	P3.3 Werkzeug-, Wälzlager-, Feder- und Schnellarbeitsstähle**	< 1.500	
	P4.1 Rostfreie Stähle, ferritisch und martensitisch		
	P5.1 Stahlguss		
	P6.1 Rostfreier Stahlguss, ferritisch und martensitisch		
	K	K1.1 Gusseisen mit Lamellengraphit (Grauguss), GJL	< 300
		K2.1 Gusseisen mit Kugelgraphit, GJS	< 500
K2.2 Gusseisen mit Kugelgraphit, GJS		≤ 800	
K2.3 Gusseisen mit Kugelgraphit, GJS		> 800	
K3.1 Gusseisen mit Vermiculargraphit, GJV; Temperguss, GJM		< 500	
K3.2 Gusseisen mit Vermiculargraphit, GJV; Temperguss, GJM		> 500	

## Typ 03 - Alu

MZG*	Werkstoff	Festigkeit/Härte [N/mm <sup>2</sup> ] [HRC]
N1	N1.1 Aluminium, unlegiert und legiert < 3 % Si	
	N1.2 Aluminium, legiert ≤ 7 % Si	
	N1.3 Aluminium, legiert > 7-12 % Si	
	N1.4 Aluminium, legiert > 12 % Si	
N2	N2.1 Kupfer, unlegiert und niedriglegiert	< 300
	N2.2 Kupfer, legiert	> 300
	N2.3 Messing, Bronze, Rotguss	< 1.200

\* MILLER Zerspanungsgruppen

\*\* Wenn die Legierungsbestandteile Cr, Mo, Ni, V, W in Summe > 8 %, dann die nächst höhere MILLER Zerspanungsgruppe wählen.



	Schnittgeschwindigkeit $v_c$ [m/min]				Vorschub $f$ [mm] bei Bohrerdurchmesser					
	Innenkühlung	Außenkühlung	MMS	Luft	12,00	15,50	19,50	25,00	32,00	40,00
	<b>110</b>	<b>100</b>	<b>100</b>		0,23	0,26	0,29	0,32	0,33	0,33
	<b>100</b>	<b>85</b>	<b>85</b>		0,29	0,33	0,37	0,40	0,41	0,41
	<b>110</b>	<b>95</b>	<b>95</b>		0,27	0,31	0,35	0,37	0,39	0,39
	<b>75</b>	<b>65</b>	<b>65</b>		0,22	0,25	0,27	0,30	0,31	0,31
	<b>85</b>	<b>70</b>	<b>70</b>		0,24	0,28	0,31	0,34	0,35	0,35
	<b>65</b>	<b>60</b>	<b>60</b>		0,20	0,23	0,25	0,27	0,28	0,29
	<b>65</b>	<b>50</b>	<b>55</b>		0,16	0,18	0,20	0,21	0,22	0,22
	<b>110</b>	<b>95</b>	<b>95</b>		0,27	0,31	0,35	0,37	0,39	0,39
	<b>110</b>	<b>75</b>	<b>75</b>	<b>75</b>	0,34	0,39	0,44	0,48	0,49	0,49
	<b>145</b>	<b>90</b>	<b>110</b>	<b>110</b>	0,31	0,36	0,40	0,44	0,45	0,46
	<b>90</b>	<b>70</b>	<b>70</b>		0,27	0,31	0,35	0,38	0,39	0,39
	<b>55</b>	<b>35</b>	<b>45</b>		0,18	0,21	0,23	0,25	0,26	0,26
	<b>80</b>	<b>70</b>	<b>70</b>		0,29	0,34	0,37	0,40	0,42	0,42
	<b>70</b>	<b>65</b>	<b>65</b>		0,23	0,27	0,30	0,32	0,33	0,33

	Schnittgeschwindigkeit $v_c$ [m/min]				Vorschub $f$ [mm] bei Bohrerdurchmesser					
	Innenkühlung	Außenkühlung	MMS	Luft	12,00	15,50	19,50	25,00	32,00	40,00
	<b>110</b>	<b>100</b>	<b>100</b>		0,26	0,30	0,34	0,36	0,38	0,38
	<b>100</b>	<b>85</b>	<b>85</b>		0,33	0,38	0,42	0,46	0,47	0,47
	<b>110</b>	<b>95</b>	<b>95</b>		0,31	0,36	0,40	0,43	0,45	0,45
	<b>75</b>	<b>65</b>	<b>65</b>		0,25	0,28	0,31	0,34	0,35	0,35
	<b>85</b>	<b>70</b>	<b>70</b>		0,28	0,32	0,36	0,39	0,40	0,41
	<b>65</b>	<b>60</b>	<b>60</b>		0,23	0,26	0,29	0,32	0,33	0,33
	<b>65</b>	<b>50</b>	<b>55</b>		0,18	0,20	0,23	0,24	0,25	0,25
	<b>65</b>	<b>50</b>	<b>55</b>		0,18	0,21	0,24	0,25	0,26	0,27
	<b>110</b>	<b>95</b>	<b>95</b>		0,31	0,36	0,40	0,43	0,45	0,45
	<b>65</b>	<b>50</b>	<b>55</b>		0,18	0,21	0,24	0,25	0,26	0,27
	<b>110</b>	<b>75</b>	<b>75</b>	<b>75</b>	0,37	0,44	0,49	0,53	0,55	0,55
	<b>145</b>	<b>90</b>	<b>110</b>	<b>110</b>	0,35	0,40	0,45	0,49	0,50	0,51
	<b>90</b>	<b>70</b>	<b>70</b>		0,30	0,35	0,39	0,42	0,43	0,43
	<b>55</b>	<b>35</b>	<b>45</b>		0,20	0,23	0,25	0,27	0,28	0,29
	<b>80</b>	<b>70</b>	<b>70</b>		0,32	0,37	0,41	0,45	0,47	0,47
	<b>70</b>	<b>65</b>	<b>65</b>		0,26	0,30	0,33	0,35	0,37	0,37

	Schnittgeschwindigkeit $v_c$ [m/min]				Vorschub $f$ [mm] bei Bohrerdurchmesser					
	Innenkühlung	Außenkühlung	MMS	Luft	12,00	15,50	19,50	25,00	32,00	40,00
	<b>300</b>	<b>200</b>	<b>250</b>		0,23	0,26	0,29	0,32	0,33	0,33
	<b>250</b>	<b>180</b>	<b>200</b>		0,30	0,35	0,39	0,42	0,43	0,43
	<b>220</b>	<b>150</b>	<b>180</b>		0,30	0,35	0,39	0,42	0,43	0,43
	<b>180</b>	<b>120</b>	<b>150</b>		0,30	0,35	0,39	0,42	0,43	0,43
	<b>140</b>	<b>100</b>			0,23	0,26	0,29	0,32	0,33	0,33
	<b>120</b>	<b>90</b>			0,30	0,35	0,39	0,42	0,43	0,43
	<b>200</b>	<b>160</b>	<b>160</b>	<b>120</b>	0,37	0,44	0,49	0,53	0,55	0,55

Die angegebenen Schnittwerte sind Richtwerte.

Die für den jeweiligen Bearbeitungsfall optimalen Daten sollten im Versuch oder während der Bearbeitung ermittelt werden.

# Schnittwertempfehlung für Wechselkopfbohrer TTD

Vorschub und Schnittgeschwindigkeit

## Typ 02 - Inox

MZG*	Werkstoff	Festigkeit/Härte [N/mm <sup>2</sup> ] [HRC]
P	P1.1 Bau-, Automaten-, Einsatz- und Vergütungsstähle, unlegiert	< 700
	P1.2 Bau-, Automaten-, Einsatz- und Vergütungsstähle, unlegiert	< 1.200
	P2.1 Nitrier-, Einsatz- und Vergütungsstähle, legiert	< 900
	P2.2 Nitrier-, Einsatz- und Vergütungsstähle, legiert	< 1.400
	P3.1 Werkzeug-, Wälzlager-, Feder- und Schnellarbeitsstähle**	< 800
	P3.2 Werkzeug-, Wälzlager-, Feder- und Schnellarbeitsstähle**	< 1.000
	P3.3 Werkzeug-, Wälzlager-, Feder- und Schnellarbeitsstähle**	< 1.500
	P4.1 Rostfreie Stähle, ferritisch und martensitisch	
	P5.1 Stahlguss	
	P6.1 Rostfreier Stahlguss, ferritisch und martensitisch	
M	M1.1 Rostfreie Stähle, austenitisch	< 700
	M1.2 Rostfreie Stähle, ferritisch/austenitisch (Duplex)	< 1.000
	M2.1 Rostfreier Stahlguss, austenitisch	< 700
	M3.1 Rostfreier Stahlguss, ferritisch/austenitisch (Duplex)	< 1.000
K	K1.1 Gusseisen mit Lamellengraphit (Grauguss), GJL	< 300
	K2.1 Gusseisen mit Kugelgraphit, GJS	< 500
	K2.2 Gusseisen mit Kugelgraphit, GJS	≤ 800
	K2.3 Gusseisen mit Kugelgraphit, GJS	> 800
	K3.1 Gusseisen mit Vermiculargraphit, GJV; Temperguss, GJM	< 500
	K3.2 Gusseisen mit Vermiculargraphit, GJV; Temperguss, GJM	> 500
N2	N2.1 Kupfer, unlegiert und niedriglegiert	< 300
	N2.2 Kupfer, legiert	> 300
	N2.3 Messing, Bronze, Rotguss	< 1.200
S	S1.1 Titan, Titanlegierungen	< 400
	S2.1 Titan, Titanlegierungen	< 1.200
	S2.2 Titan, Titanlegierungen	> 1.200
	S3.1 Nickel, unlegiert und legiert	< 900
	S3.2 Nickel, unlegiert und legiert	> 900
	S4.1 Hochwarmfeste Superlegierung, Ni-, Co-, und Fe-basiert	
	S5.1 Wolfram- und Molybdänlegierungen	

## Typ 05 - Iron

MZG*	Werkstoff	Festigkeit/Härte [N/mm <sup>2</sup> ] [HRC]
K	K1.1 Gusseisen mit Lamellengraphit (Grauguss), GJL	< 300
	K2.1 Gusseisen mit Kugelgraphit, GJS	< 500
	K2.2 Gusseisen mit Kugelgraphit, GJS	≤ 800
	K2.3 Gusseisen mit Kugelgraphit, GJS	> 800
	K3.1 Gusseisen mit Vermiculargraphit, GJV; Temperguss, GJM	< 500
	K3.2 Gusseisen mit Vermiculargraphit, GJV; Temperguss, GJM	> 500

\* MILLER Zerspanungsgruppen

\*\* Wenn die Legierungsbestandteile Cr, Mo, Ni, V, W in Summe > 8 %, dann die nächst höhere MILLER Zerspanungsgruppe wählen.

	Schnittgeschwindigkeit $v_c$ [m/min]				Vorschub $f$ [mm] bei Bohrerdurchmesser					
	Innenkühlung	Außenkühlung	MMS	Luft	12,00	15,50	19,50	25,00	32,00	40,00
	<b>100</b>	<b>90</b>	<b>90</b>		0,21	0,24	0,26	0,28	0,30	0,30
	<b>90</b>	<b>75</b>	<b>75</b>		0,26	0,30	0,33	0,36	0,37	0,37
	<b>100</b>	<b>85</b>	<b>85</b>		0,24	0,28	0,31	0,34	0,35	0,35
	<b>70</b>	<b>60</b>	<b>60</b>		0,19	0,22	0,25	0,27	0,28	0,28
	<b>75</b>	<b>65</b>	<b>65</b>		0,22	0,25	0,28	0,30	0,32	0,32
	<b>60</b>	<b>55</b>	<b>55</b>		0,18	0,21	0,23	0,25	0,26	0,26
	<b>60</b>	<b>45</b>	<b>50</b>		0,14	0,16	0,18	0,19	0,20	0,20
	<b>60</b>	<b>45</b>	<b>50</b>		0,14	0,17	0,18	0,20	0,21	0,21
	<b>100</b>	<b>85</b>	<b>85</b>		0,24	0,28	0,31	0,34	0,35	0,35
	<b>60</b>	<b>45</b>	<b>50</b>		0,14	0,17	0,18	0,20	0,21	0,21
	<b>55</b>	<b>35</b>	<b>35</b>		0,18	0,21	0,24	0,25	0,26	0,27
	<b>50</b>	<b>30</b>	<b>30</b>		0,16	0,18	0,20	0,22	0,23	0,23
	<b>55</b>	<b>35</b>	<b>35</b>		0,18	0,21	0,24	0,25	0,26	0,27
	<b>50</b>	<b>30</b>	<b>30</b>		0,16	0,18	0,20	0,22	0,23	0,23
	<b>95</b>	<b>70</b>	<b>70</b>	<b>70</b>	0,34	0,39	0,44	0,48	0,49	0,49
	<b>130</b>	<b>80</b>	<b>95</b>	<b>95</b>	0,31	0,36	0,40	0,44	0,45	0,46
	<b>80</b>	<b>60</b>	<b>60</b>		0,27	0,31	0,35	0,38	0,39	0,39
	<b>50</b>	<b>30</b>	<b>40</b>		0,18	0,21	0,23	0,25	0,26	0,26
	<b>70</b>	<b>65</b>	<b>65</b>		0,29	0,34	0,37	0,40	0,42	0,42
	<b>65</b>	<b>55</b>	<b>55</b>		0,23	0,27	0,30	0,32	0,33	0,33
	<b>140</b>	<b>100</b>			0,23	0,26	0,29	0,32	0,33	0,33
	<b>120</b>	<b>90</b>			0,30	0,35	0,39	0,42	0,43	0,43
	<b>200</b>	<b>160</b>	<b>160</b>	<b>120</b>	0,37	0,44	0,49	0,53	0,55	0,55
	<b>40</b>	<b>25</b>			0,16	0,18	0,21	0,22	0,23	0,23
	<b>30</b>	<b>20</b>			0,14	0,16	0,18	0,19	0,20	0,20
	<b>25</b>	<b>15</b>			0,11	0,13	0,15	0,16	0,16	0,17
	<b>20</b>	<b>15</b>			0,09	0,11	0,12	0,13	0,13	0,13
	<b>15</b>	<b>10</b>			0,11	0,13	0,15	0,16	0,16	0,17
	<b>15</b>	<b>10</b>			0,09	0,11	0,12	0,13	0,13	0,13
	<b>15</b>	<b>10</b>			0,09	0,11	0,12	0,13	0,13	0,13

	Schnittgeschwindigkeit $v_c$ [m/min]				Vorschub $f$ [mm] bei Bohrerdurchmesser					
	Innenkühlung	Außenkühlung	MMS	Luft	12,00	15,50	19,50	25,00	32,00	40,00
	<b>120</b>	<b>85</b>	<b>85</b>	<b>85</b>	0,45	0,52	0,58	0,63	0,66	0,66
	<b>160</b>	<b>100</b>	<b>120</b>	<b>120</b>	0,42	0,48	0,54	0,58	0,60	0,61
	<b>100</b>	<b>75</b>	<b>75</b>		0,36	0,42	0,46	0,50	0,52	0,52
	<b>60</b>	<b>40</b>	<b>50</b>		0,24	0,28	0,30	0,33	0,34	0,34
	<b>90</b>	<b>80</b>	<b>80</b>		0,39	0,45	0,50	0,54	0,56	0,56
	<b>80</b>	<b>70</b>	<b>70</b>		0,31	0,36	0,39	0,43	0,44	0,44

Die angegebenen Schnittwerte sind Richtwerte.

Die für den jeweiligen Bearbeitungsfall optimalen Daten sollten im Versuch oder während der Bearbeitung ermittelt werden.

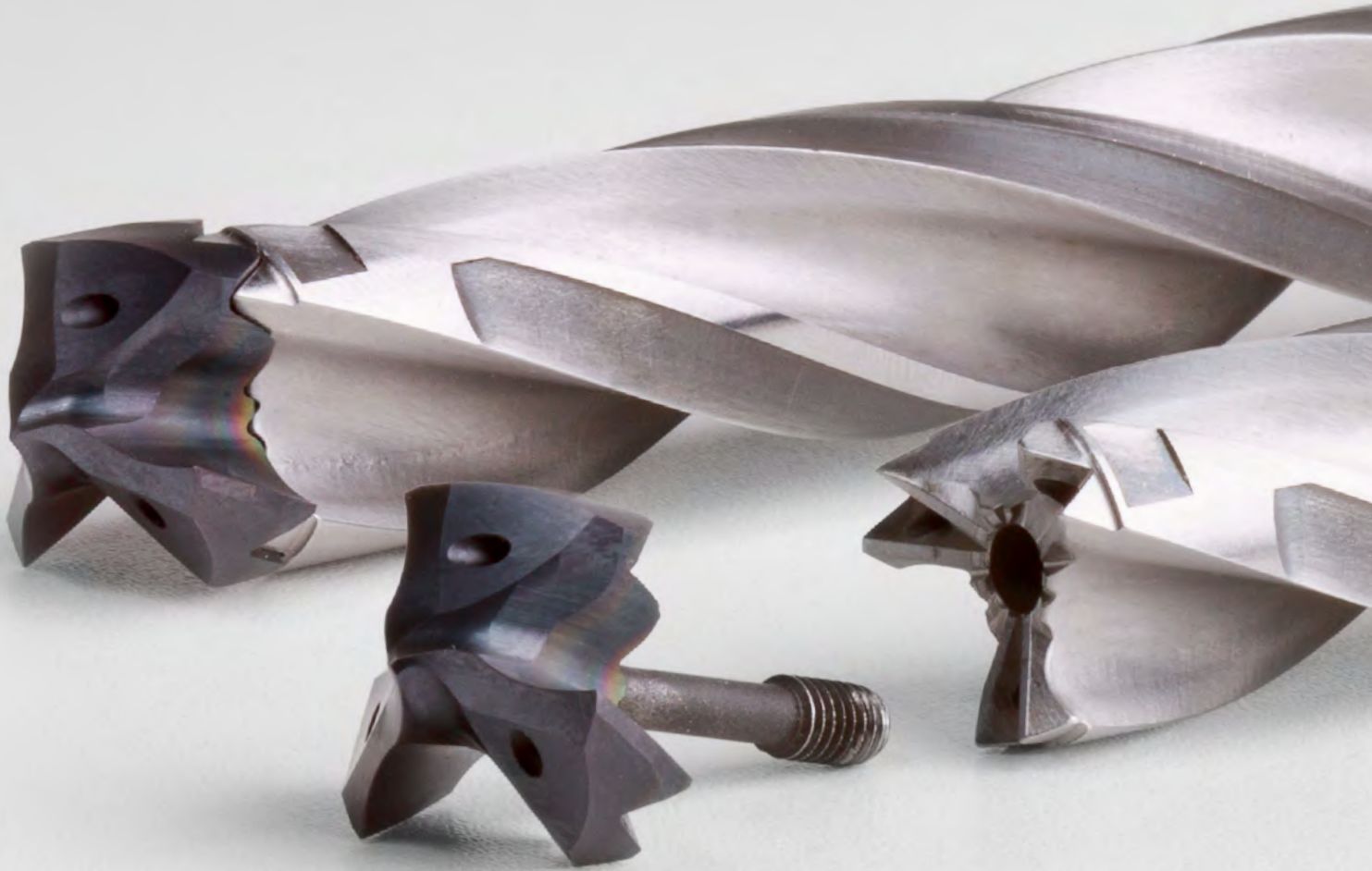

# WECHSELKOPFBOHRER TTD-TRITAN

## Minimierter Einsatz von Hartmetall bei höchster Stabilität und Präzision

Auch der dreischneidige Tritan-Drill steht als Wechselkopf-Variante zur Verfügung.

Werkzeugkopf und Werkzeughalter sind über eine Hirth-Verzahnung verbunden. Diese Schnittstelle ist besonders stabil, so dass mit der Wechselkopfvariante alle Vorteile sowie das Leistungsniveau des Pendants aus Vollhartmetall bestehen bleiben. Die Stabilität der Schnittstelle beruht unter anderem auf der Dreischneidigkeit, die prädestiniert ist für ein Wechselkopfsystem.

Durch die drei Schneiden ist die Belastung der Schnittstelle homogen, das heißt die Kräfte, die bei der Zerspanung entstehen, werden gleichmäßig an den Werkzeughalter aus Stahl übertragen. Zudem garantiert die Schnittstelle optimale Drehmomentübertragung bei gleichzeitig hoher Wechsel- und Rundlaufgenauigkeit.

Gegenüber zweischneidigen Wechselkopfbohrern aus Vollhartmetall können mit dem TTD-Tritan bis zu doppelt so hohe Vorschübe realisiert werden.

Im Ergebnis kann prozesssicher und stabil auch bei schwierigen Bohrsituationen, wie bei schrägem Bohrungseintritt oder bei Querbohrungen, gearbeitet werden. Das Werkzeug zentriert sich optimal über seine ausgeprägte Bohrspitze und sorgt für sehr gute Rundheit. Und das zu geringeren Kosten als bei Vollhartmetallbohrern. Denn mit dem neuen Wechselkopfsystem ist das kostenintensive Hartmetall auf den Werkzeugkopf beschränkt. So sind geringere Kosten auch bei großen Durchmessern garantiert.

## Werkzeugfeatures im Detail

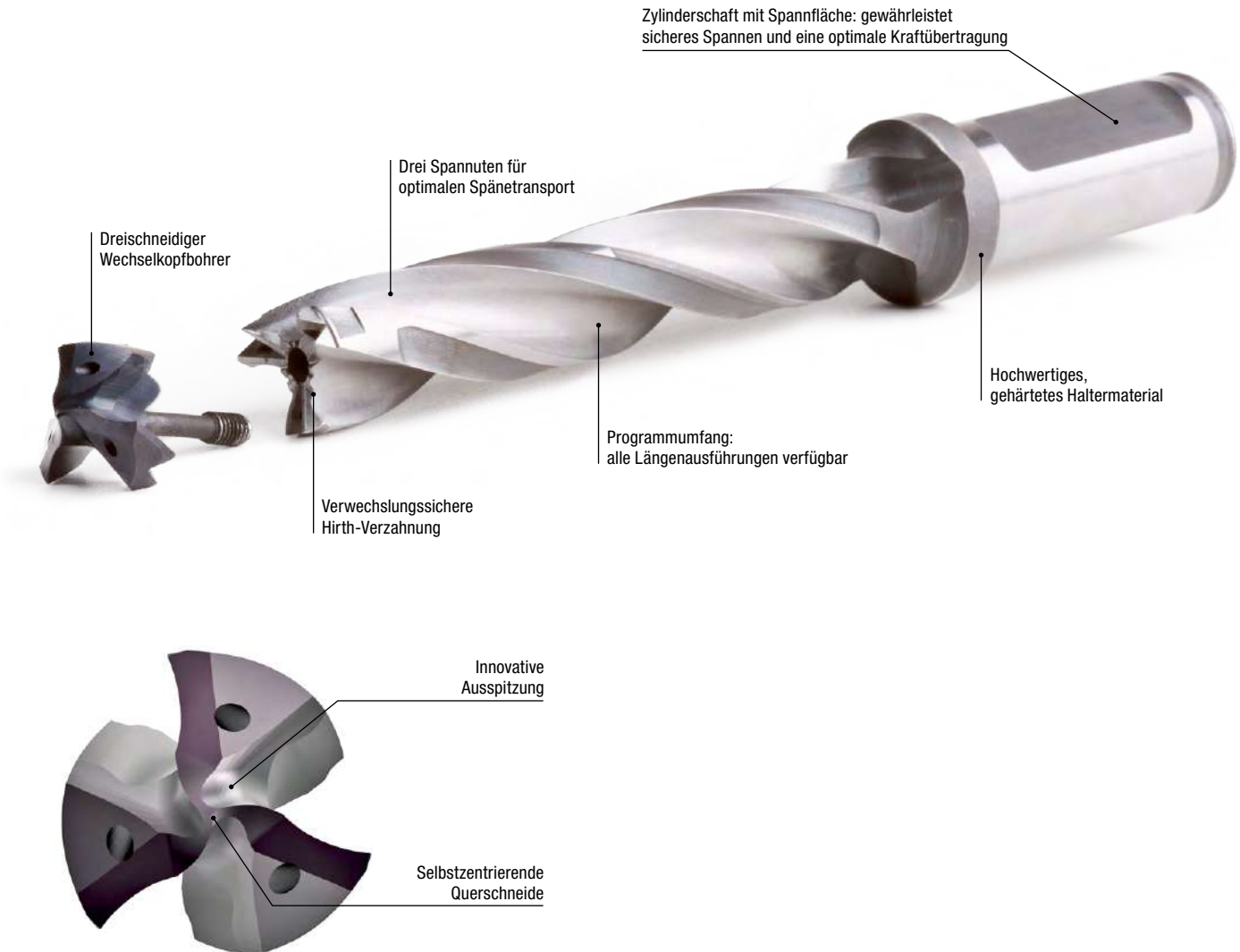

### AUF EINEN BLICK

- Dreischneidiger Wechselkopfbohrer
- $\emptyset$ -Bereich 12,00 bis 32,49 mm
- Bohrtiefen 3 | 5 und 8xD
- Mit Innenkühlung
- Einfaches Handling
- Kopfwechsel in der Maschine möglich

### LEISTUNGSMERKMALE

- Bis zu doppelter Vorschub gegenüber zweischneidigen Wechselkopfbohrern
- Hohe Wechsel- und Rundlaufgenauigkeit
- Optimal bei schrägem Bohrungseintritt
- Werkzeug zentriert sich über seine ausgeprägte Bohrspitze
- Hohe Drehmomentübertragung

### VORTEILE

- Signifikante Steigerungen von Vorschubgeschwindigkeit und Standweg
- Tritan-Geometrie für gute Bohrungsergebnisse
- Hohe Prozesssicherheit und Stabilität auch bei schwierigen Bohrsituationen
- Homogene Belastung der Schnittstelle durch drei Schneiden

# Wechselbohrkopf TTD-Tritan

Aus Vollhartmetall, innere Kühlmittelzufuhr  
Typ 01 - Uni

## Ausführung:

Bohrerdurchmesser: 12,00 - 32,49 mm  
Bohrungstoleranz: IT 9 (erreichbar)  
Beschichtung: MxP  
Schneidenanzahl: 3  
Anzahl Führungsfasen: 3  
Spitzenwinkel: 140°

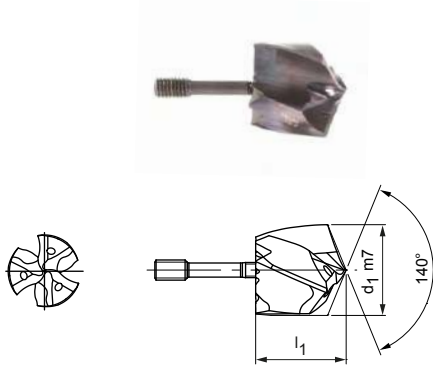

## Lagerhaltige Vorzugsbaureihe

d <sub>1</sub> von 13,50 bis 20,00		
d <sub>1</sub> m7	Spezifikation	Bestell-Nr.
13,50	TTD300-3F01-1350-MxP	30870959
14,00	TTD300-3F01-1400-MxP	30870964
14,40	TTD300-3F01-1440-MxP	30870968
14,60	TTD300-3F01-1460-MxP	30870970
15,00	TTD300-3F01-1500-MxP	30870974
15,10	TTD300-3F01-1510-MxP	30870975
15,20	TTD300-3F01-1520-MxP	30870976
15,38	TTD300-3F01-1538-MxP	31290678
15,40	TTD300-3F01-1540-MxP	30870978
16,00	TTD300-3F01-1600-MxP	30870984
16,50	TTD300-3F01-1650-MxP	30870989
17,00	TTD300-3F01-1700-MxP	30870994
17,50	TTD300-3F01-1750-MxP	30870999
18,00	TTD300-3F01-1800-MxP	30871004
18,50	TTD300-3F01-1850-MxP	30871009
19,00	TTD300-3F01-1900-MxP	30871014
19,80	TTD300-3F01-1980-MxP	30871022
20,00	TTD300-3F01-2000-MxP	30871024

d <sub>1</sub> von 20,50 bis 32,00		
d <sub>1</sub> m7	Spezifikation	Bestell-Nr.
20,50	TTD300-3F01-2050-MxP	30871029
21,00	TTD300-3F01-2100-MxP	30871035
22,00	TTD300-3F01-2200-MxP	30871045
24,00	TTD300-3F01-2400-MxP	30871065
24,70	TTD300-3F01-2470-MxP	30871072
25,00	TTD300-3F01-2500-MxP	30871075
25,10	TTD300-3F01-2510-MxP	30871076
25,20	TTD300-3F01-2520-MxP	30871077
26,00	TTD300-3F01-2600-MxP	30871085
26,10	TTD300-3F01-2610-MxP	30871086
26,50	TTD300-3F01-2650-MxP	30871090
27,00	TTD300-3F01-2700-MxP	30871095
27,10	TTD300-3F01-2710-MxP	30871096
28,00	TTD300-3F01-2800-MxP	30871105
28,50	TTD300-3F01-2850-MxP	30871110
31,00	TTD300-3F01-3100-MxP	30871135
32,00	TTD300-3F01-3200-MxP	30871145

## Konfigurierbare Merkmale



**Durchmesser:**  
Durchmesser in Abstufungen  
von 0,01 mm frei wählbar



### Spezifikation:

TTD300-3F01-[Durchmesser]-MxP

## Abmessungen konfigurierbare Baureihe

d <sub>1</sub> min.	d <sub>1</sub> max.
12,00	32,49

### Beispiel:

TTD300-4F03-1401-MxP

Werkzeugdurchmesser d<sub>1</sub> = 14,01 mm

Maßangaben in mm.

Schnittwertempfehlung siehe Kapitelende.

Sonderausführungen und andere Beschichtungen auf Anfrage.

# Wechselkopfhalter TTS

TTS300 mit Axialspannsystem für Wechselkopfbohrer TTD-Tritan (3xD),  
innere Kühlmittelzufuhr

**Ausführung:**

Bohrerdurchmesser:

12,00 - 32,49 mm

Wechselsystem:

 Zentrale Spannung  
über Kühlmittel-  
bohrung

**Anmerkung:**

Montageschlüssel im Lieferumfang enthalten.

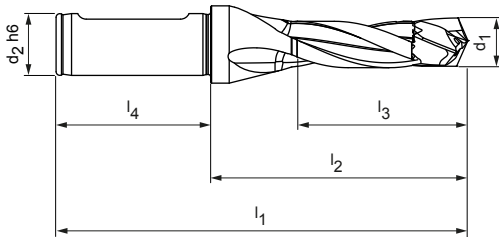

## Lagerhaltige Vorzugsbaureihe

Baumaße						Schaftform HB	
d <sub>1</sub>	d <sub>2</sub> h6	l <sub>1</sub>	l <sub>2</sub>	l <sub>3</sub>	l <sub>4</sub>	Spezifikation	Bestell-Nr.
14,00 - 14,49	16	120	72	48	48	TTS300B-1400-DR3-ZYL-16-MN	30857298
14,50 - 14,99	16	122	74	49	48	TTS300B-1450-DR3-ZYL-16-MN	30857299
15,00 - 15,49	16	124	76	51	48	TTS300B-1500-DR3-ZYL-16-MN	30857300
17,50 - 18,49	20	140	90	61	50	TTS300B-1750-DR3-ZYL-20-MN	30857303
18,50 - 19,49	25	150	94	64	56	TTS300B-1850-DR3-ZYL-25-MN	30857304
20,50 - 21,49	25	159	103	71	56	TTS300B-2050-DR3-ZYL-25-MN	30857306
21,50 - 22,49	25	164	108	74	56	TTS300B-2150-DR3-ZYL-25-MN	30857307
24,50 - 25,49	32	182	122	84	60	TTS300B-2450-DR3-ZYL-32-MN	30857311
26,50 - 27,49	32	191	131	91	60	TTS300B-2650-DR3-ZYL-32-MN	30857313

## Auf Anfrage erhältlich

Baumaße						Schaftform HB	
d <sub>1</sub>	d <sub>2</sub> h6	l <sub>1</sub>	l <sub>2</sub>	l <sub>3</sub>	l <sub>4</sub>	Spezifikation	Bestell-Nr.
12,00 - 12,49	16	111	63	39	48	TTS300B-1200-DR3-ZYL-16-MN	30857294
12,50 - 12,99	16	113	65	43	48	TTS300B-1250-DR3-ZYL-16-MN	30857295
13,00 - 13,49	16	115	67	45	48	TTS300B-1300-DR3-ZYL-16-MN	30857296
13,50 - 13,99	16	117	69	46	48	TTS300B-1350-DR3-ZYL-16-MN	30857297
15,50 - 16,49	20	131	81	54	50	TTS300B-1550-DR3-ZYL-20-MN	30857301
16,50 - 17,49	20	135	85	58	50	TTS300B-1650-DR3-ZYL-20-MN	30857302
19,50 - 20,49	25	155	99	68	56	TTS300B-1950-DR3-ZYL-25-MN	30857305
22,50 - 23,49	25	168	112	78	56	TTS300B-2250-DR3-ZYL-25-MN	30857309
23,50 - 24,49	25	173	117	81	56	TTS300B-2350-DR3-ZYL-25-MN	30857310
25,50 - 26,49	32	186	126	87	60	TTS300B-2550-DR3-ZYL-32-MN	30857312
27,50 - 28,49	32	195	135	94	60	TTS300B-2750-DR3-ZYL-32-MN	30857314
28,50 - 29,49	32	200	140	97	60	TTS300B-2850-DR3-ZYL-32-MN	30857315
29,50 - 30,49	32	204	144	101	60	TTS300B-2950-DR3-ZYL-32-MN	30857316
30,50 - 31,49	32	209	149	104	60	TTS300B-3050-DR3-ZYL-32-MN	30857317
31,50 - 32,49	32	213	153	107	60	TTS300B-3150-DR3-ZYL-32-MN	30857318

Maßangaben in mm.

Sonderausführungen auf Anfrage.

# Wechselkopfhalter TTS

TTS300 mit Axialspannsystem für Wechselkopfbohrer TTD-Tritan (5xD),  
innere Kühlmittelzufuhr

**Ausführung:**

Bohrerdurchmesser:

12,00 - 32,49 mm

Wechselsystem:

 Zentrale Spannung  
über Kühlmittel-  
bohrung

**Anmerkung:**

Montageschlüssel im Lieferumfang enthalten.

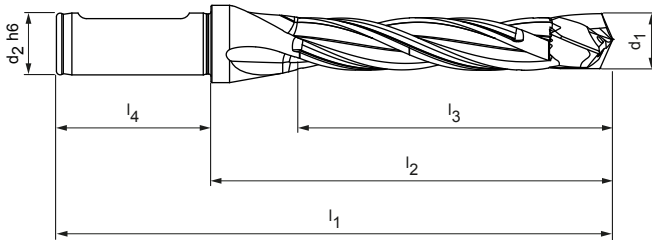
**Lagerhaltige Vorzugsbaureihe**

Baumaße						Schaftform HB	
d <sub>1</sub>	d <sub>2</sub> h6	l <sub>1</sub>	l <sub>2</sub>	l <sub>3</sub>	l <sub>4</sub>	Spezifikation	Bestell-Nr.
14,00 - 14,49	16	149	101	77	48	TTS300B-1400-DR5-ZYL-16-MN	30857323
15,00 - 15,49	16	155	107	82	48	TTS300B-1500-DR5-ZYL-16-MN	30857325
16,50 - 17,49	20	170	120	93	50	TTS300B-1650-DR5-ZYL-20-MN	30857327
17,50 - 18,49	20	177	127	98	50	TTS300B-1750-DR5-ZYL-20-MN	30857328
23,50 - 24,49	25	222	166	130	56	TTS300B-2350-DR5-ZYL-25-MN	30857334
24,50 - 25,49	32	233	173	135	60	TTS300B-2450-DR5-ZYL-32-MN	30857335
26,50 - 27,49	32	246	186	146	60	TTS300B-2650-DR5-ZYL-32-MN	30857337

**Auf Anfrage erhältlich**

Baumaße						Schaftform HB	
d <sub>1</sub>	d <sub>2</sub> h6	l <sub>1</sub>	l <sub>2</sub>	l <sub>3</sub>	l <sub>4</sub>	Spezifikation	Bestell-Nr.
12,00 - 12,49	16	136	88	66	48	TTS300B-1200-DR5-ZYL-16-MN	30857319
12,50 - 12,99	16	139	91	69	48	TTS300B-1250-DR5-ZYL-16-MN	30857320
13,00 - 13,49	16	142	94	71	48	TTS300B-1300-DR5-ZYL-16-MN	30857321
13,50 - 13,99	16	145	97	74	48	TTS300B-1350-DR5-ZYL-16-MN	30857322
14,50 - 14,99	16	152	104	79	48	TTS300B-1450-DR5-ZYL-16-MN	30857324
15,50 - 16,49	20	164	114	87	50	TTS300B-1550-DR5-ZYL-20-MN	30857326
18,50 - 19,49	25	189	133	103	56	TTS300B-1850-DR5-ZYL-25-MN	30857329
19,50 - 20,49	25	196	140	109	56	TTS300B-1950-DR5-ZYL-25-MN	30857330
20,50 - 21,49	25	202	146	114	56	TTS300B-2050-DR5-ZYL-25-MN	30857331
21,50 - 22,49	25	209	153	119	56	TTS300B-2150-DR5-ZYL-25-MN	30857332
22,50 - 23,49	25	215	159	124	56	TTS300B-2250-DR5-ZYL-25-MN	30857333
25,50 - 26,49	32	239	179	140	60	TTS300B-2550-DR5-ZYL-32-MN	30857336
27,50 - 28,49	32	252	192	151	60	TTS300B-2750-DR5-ZYL-32-MN	30857338
28,50 - 29,49	32	259	199	156	60	TTS300B-2850-DR5-ZYL-32-MN	30857339
29,50 - 30,49	32	265	205	162	60	TTS300B-2950-DR5-ZYL-32-MN	30857340
30,50 - 31,49	32	272	212	167	60	TTS300B-3050-DR5-ZYL-32-MN	30857341
31,50 - 32,49	32	278	218	172	60	TTS300B-3150-DR5-ZYL-32-MN	30857342

Maßangaben in mm.

Sonderausführungen auf Anfrage.



# Wechselkopfhalter TTS

TTS300 mit Axialspannsystem für Wechselkopfbohrer TTD-Tritan (8xD),  
innere Kühlmittelzufuhr

**Ausführung:**

Bohrerdurchmesser:

12,00 - 32,49 mm

Wechselsystem:

 Zentrale Spannung  
über Kühlmittel-  
bohrung

**Anmerkung:**

Montageschlüssel im Lieferumfang enthalten.

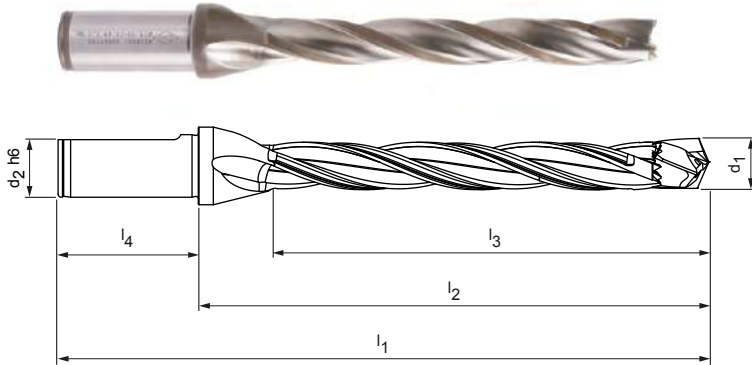
**Lagerhaltige Vorzugsbaureihe**

Baumaße						Schaftform HB	
d <sub>1</sub>	d <sub>2</sub> h6	l <sub>1</sub>	l <sub>2</sub>	l <sub>3</sub>	l <sub>4</sub>	Spezifikation	Bestell-Nr.
15,50 - 16,49	20	213	163	137	50	TTS300B-1550-DR8-ZYL-20-MN	30867726
20,50 - 21,49	25	267	211	178	56	TTS300B-2050-DR8-ZYL-25-MN	30867731

**Auf Anfrage erhältlich**

Baumaße						Schaftform HB	
d <sub>1</sub>	d <sub>2</sub> h6	l <sub>1</sub>	l <sub>2</sub>	l <sub>3</sub>	l <sub>4</sub>	Spezifikation	Bestell-Nr.
12,00 - 12,49	16	173	125	104	48	TTS300B-1200-DR8-ZYL-16-MN	30867719
12,50 - 12,99	16	178	130	108	48	TTS300B-1250-DR8-ZYL-16-MN	30867720
13,00 - 13,49	16	183	135	112	48	TTS300B-1300-DR8-ZYL-16-MN	30867721
13,50 - 13,99	16	187	139	116	48	TTS300B-1350-DR8-ZYL-16-MN	30867722
14,00 - 14,49	16	192	144	120	48	TTS300B-1400-DR8-ZYL-16-MN	30867723
14,50 - 14,99	16	197	149	124	48	TTS300B-1450-DR8-ZYL-16-MN	30867724
15,00 - 15,49	16	202	154	129	48	TTS300B-1500-DR8-ZYL-16-MN	30867725
16,50 - 17,49	20	223	173	145	50	TTS300B-1650-DR8-ZYL-20-MN	30867727
17,50 - 18,49	20	232	182	153	50	TTS300B-1750-DR8-ZYL-20-MN	30867728
18,50 - 19,49	25	248	192	162	56	TTS300B-1850-DR8-ZYL-25-MN	30867729
19,50 - 20,49	25	257	201	170	56	TTS300B-1950-DR8-ZYL-25-MN	30867730
21,50 - 22,49	25	276	220	187	56	TTS300B-2150-DR8-ZYL-25-MN	30867732
22,50 - 23,49	25	286	230	195	56	TTS300B-2250-DR8-ZYL-25-MN	30867733
23,50 - 24,49	25	295	239	203	56	TTS300B-2350-DR8-ZYL-25-MN	30867734
24,50 - 25,49	32	309	249	212	60	TTS300B-2450-DR8-ZYL-32-MN	30867735
25,50 - 26,49	32	319	259	220	60	TTS300B-2550-DR8-ZYL-32-MN	30867736
26,50 - 27,49	32	328	268	228	60	TTS300B-2650-DR8-ZYL-32-MN	30867737
27,50 - 28,49	32	338	278	236	60	TTS300B-2750-DR8-ZYL-32-MN	30867738
28,50 - 29,49	32	342	282	245	60	TTS300B-2850-DR8-ZYL-32-MN	30867739
29,50 - 30,49	32	352	292	253	60	TTS300B-2950-DR8-ZYL-32-MN	30867740
30,50 - 31,49	32	361	301	261	60	TTS300B-3050-DR8-ZYL-32-MN	30867741
31,50 - 32,49	32	371	311	270	60	TTS300B-3150-DR8-ZYL-32-MN	30867742

Maßangaben in mm.

Sonderausführungen auf Anfrage.



## Zubehör und Ersatzteile für TTD-Tritan



### TORX®-Schlüssel

Durchmesserbereich Wechselbohrkopf TTD-Tritan	Torx	Anzugsdrehmoment Spezialspannschraube [Nm]	Bestell-Nr.
			für Halterlänge 3xD, 5xD und 8xD
12,00 - 12,49	6	0,4	30890316
12,50 - 12,99			
13,00 - 13,49			
13,50 - 13,99			
14,00 - 14,49	7	0,7	30890318
14,50 - 14,99			
15,00 - 15,49			
15,50 - 16,49			
16,50 - 17,49	8	1,3	30890321
17,50 - 18,49			
18,50 - 19,49			
19,50 - 20,49			
20,50 - 21,49	10	2	30890323
21,50 - 22,49			
22,50 - 23,49			
23,50 - 24,49			
24,50 - 25,49	15	3,1	30890326
25,50 - 26,49			
26,50 - 27,49			
27,50 - 28,49		5,6	
28,50 - 29,49			
29,50 - 30,49			
30,50 - 31,49			
31,50 - 32,49			

**Drehmomentschlüssel**

Zubehör	Anzugsdrehmomentbereich [Nm]	Bestell-Nr.
Drehmomentschlüssel 	0,2 - 1,2	30911425
Drehmomentschlüssel 	1,0 - 6,0	30911426

**Griff für TORX®-Schlüssel**

Erstzulassung	Einsteckschaft	Bestell-Nr.
Multi-Griff 	Innensechskant 1/4"	30918896

# Schnittwertempfehlung für Wechselkopfbohrer TTD-Tritan

Vorschub und Schnittgeschwindigkeit

## Typ 01 - Uni

MZG*	Werkstoff	Festigkeit/Härte [N/mm <sup>2</sup> ] [HRC]
P	P1.1 Bau-, Automaten-, Einsatz- und Vergütungsstähle, unlegiert	< 700
	P1.2 Bau-, Automaten-, Einsatz- und Vergütungsstähle, unlegiert	< 1.200
	P2.1 Nitrier-, Einsatz- und Vergütungsstähle, legiert	< 900
	P2.2 Nitrier-, Einsatz- und Vergütungsstähle, legiert	< 1.400
	P3.1 Werkzeug-, Wälzlager-, Feder- und Schnellarbeitsstähle**	< 800
	P3.2 Werkzeug-, Wälzlager-, Feder- und Schnellarbeitsstähle**	< 1.000
	P3.3 Werkzeug-, Wälzlager-, Feder- und Schnellarbeitsstähle**	< 1.500
	P5.1 Stahlguss	
K	K1.1 Gusseisen mit Lamellengraphit (Grauguss), GJL	< 300
	K2.1 Gusseisen mit Kugelgraphit, GJS	< 500
	K2.2 Gusseisen mit Kugelgraphit, GJS	≤ 800
	K2.3 Gusseisen mit Kugelgraphit, GJS	> 800
	K3.1 Gusseisen mit Vermiculargraphit, GJV; Temperguss, GJM	< 500
	K3.2 Gusseisen mit Vermiculargraphit, GJV; Temperguss, GJM	> 500

\* MILLER Zerspanungsgruppen

\*\* Wenn die Legierungsbestandteile Cr, Mo, Ni, V in Summe > 8 %, dann die nächst höhere MILLER Zerspanungsgruppe wählen.

	Schnittgeschwindigkeit $v_c$ [m/min]				Vorschub $f$ [mm] bei Bohrerdurchmesser					
	Innenkühlung	Außenkühlung	MMS	Luft	12,00	14,50	17,50	21,50	26,00	32,00
	<b>90</b>	<b>80</b>	<b>80</b>		0,38	0,42	0,46	0,50	0,53	0,54
	<b>80</b>	<b>70</b>	<b>70</b>		0,47	0,53	0,58	0,63	0,66	0,68
	<b>90</b>	<b>75</b>	<b>75</b>		0,45	0,50	0,55	0,59	0,62	0,64
	<b>65</b>	<b>55</b>	<b>55</b>		0,36	0,40	0,43	0,47	0,49	0,51
	<b>70</b>	<b>60</b>	<b>60</b>		0,40	0,45	0,49	0,53	0,56	0,58
	<b>55</b>	<b>50</b>	<b>50</b>		0,33	0,37	0,40	0,43	0,46	0,47
	<b>55</b>	<b>40</b>	<b>45</b>		0,26	0,28	0,31	0,33	0,35	0,36
	<b>90</b>	<b>75</b>	<b>75</b>		0,45	0,50	0,55	0,59	0,62	0,64
	<b>110</b>	<b>75</b>	<b>75</b>	<b>75</b>	0,62	0,69	0,77	0,83	0,88	0,90
	<b>145</b>	<b>90</b>	<b>110</b>	<b>110</b>	0,57	0,64	0,71	0,77	0,81	0,83
	<b>90</b>	<b>70</b>	<b>70</b>		0,49	0,55	0,61	0,66	0,69	0,71
	<b>55</b>	<b>35</b>	<b>45</b>		0,33	0,37	0,40	0,43	0,46	0,47
	<b>80</b>	<b>70</b>	<b>70</b>		0,53	0,59	0,65	0,71	0,75	0,77
	<b>70</b>	<b>65</b>	<b>65</b>		0,43	0,47	0,52	0,56	0,59	0,61

Die angegebenen Schnittwerte sind Richtwerte.

Die für den jeweiligen Bearbeitungsfall optimalen Daten sollten im Versuch oder während der Bearbeitung ermittelt werden.



# ANBOHREN

## Anbohrer

---

Tritan-Spot-Drill-Steel ..... 256

ECU-Centre-Drill ..... 258

## Technischer Anhang

---

Schnittwertempfehlung ..... 260

# Tritan-Spot-Drill-Steel

Vollhartmetall-NC-Anbohrer  
M9930, äußere Kühlmittelzufuhr

**Ausführung:**  
Bohrerdurchmesser: 4,00 - 20,00 mm  
Schaftform: HA (DIN 6535)  
Beschichtung: MxP  
Schneidenanzahl: 3  
Spitzenwinkel: 155°

**Anwendung:**  
Spezieller NC-Anbohrer für den Tritan-Drill-Steel.

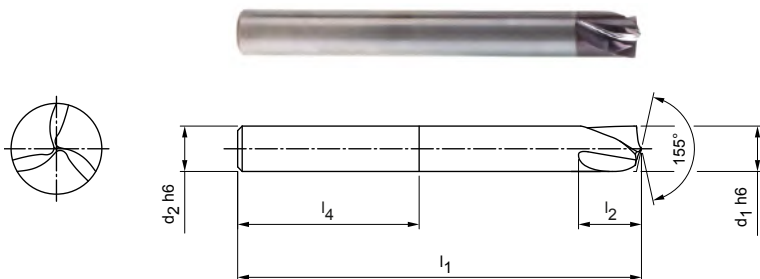

## Lagerhaltige Vorzugsbaureihe

Baumaße					Schaftform HA	
d <sub>1</sub> h6	d <sub>2</sub> h6	l <sub>1</sub>	l <sub>2</sub>	l <sub>4</sub>	Spezifikation	Bestell-Nr.
4,00	4	55	6	28	M9930-0400AR	30894971
5,00	6	62	7	36	M9930-0500AR	30894972
6,00	6	66	9	36	M9930-0600AR	30894973
8,00	8	79	11	36	M9930-0800AR	30894974
10,00	10	89	14	40	M9930-1000AR	30894975
12,00	12	102	17	45	M9930-1200AR	30894976
16,00	16	115	23	48	M9930-1600AR	30894977
20,00	20	131	28	50	M9930-2000AR	30894978

## Anbohrtiefen

d <sub>1</sub> h6	d <sub>2</sub> h6	l <sub>1</sub>	l <sub>2</sub>	l <sub>4</sub>	Maximale Anbohrtiefe *	Minimale Anbohrtiefe **
4,00	4	55	6	28	0,40	0,24
5,00	6	62	7	36	0,50	0,30
6,00	6	66	9	36	0,60	0,36
8,00	8	79	11	36	0,80	0,48
10,00	10	89	14	40	1,00	0,60
12,00	12	102	17	45	1,20	0,72
16,00	16	115	23	48	1,60	0,96
20,00	20	131	28	50	2,00	1,20

\* 10 % der Nenn-Ø

\*\* 6 % der Nenn-Ø

Maßangaben in mm.

Schnittwertempfehlung siehe Kapitelende.

Sonderausführungen und andere Beschichtungen auf Anfrage.



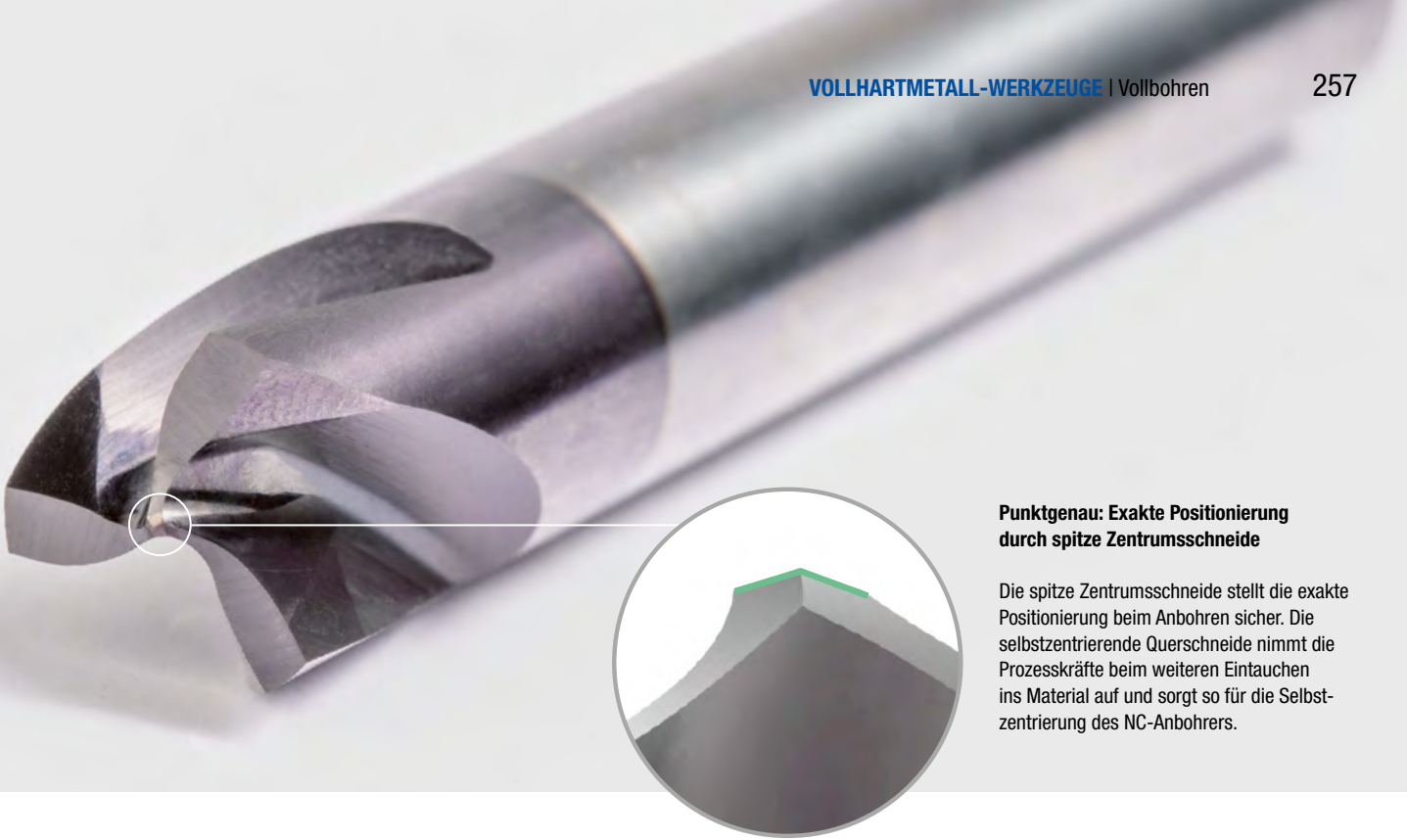

**Punktgenau: Exakte Positionierung durch spitze Zentrumschneide**

Die spitze Zentrumschneide stellt die exakte Positionierung beim Anbohren sicher. Die selbstzentrierende Querschneide nimmt die Prozesskräfte beim weiteren Eintauchen ins Material auf und sorgt so für die Selbstzentrierung des NC-Anbohrers.

### Tritan-Drill-Steel



Die Spitzenwinkel des Tritan-Spot-Drill-Steel (155°) und des Tritan-Drill-Steel (140°/145°) sind perfekt aufeinander abgestimmt.

Der Tritan-Drill-Steel ist erhältlich in:



M9933 | 3xD



M9935 | 5xD



M9938 | 8xD



M9942 | 12xD

### Bohrstrategie 3xD bis 12xD:

Maximale Anbohrtiefe: 10 %  
(%-Angabe des  
Nenndurchmessers)

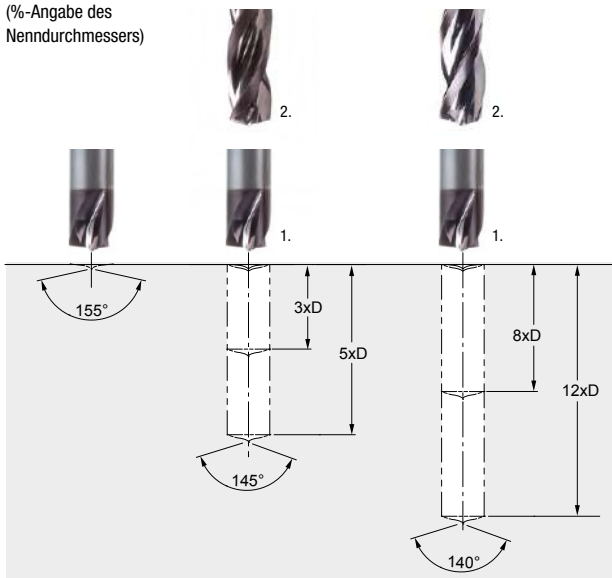

### AUF EINEN BLICK

- Dreischneidiger NC-Anbohrer mit 155° Spitzenwinkel
- Perfekt auf den Tritan-Drill-Steel abgestimmt
- Hohe Positionsgenauigkeit
- Selbstzentrierende Querschneide
- Geeignet auch für schwierige Bohrsituationen

# ECU-Centre-Drill

Vollhartmetall-Zentrierbohrer  
M1200

## Ausführung:

Bohrerdurchmesser: 0,50 - 2,50 mm  
 Beschichtung: Unbeschichtet  
 Schneidanzahl: 2  
 Anzahl Führungsfasen: 2  
 Spitzenwinkel: 120°/60°  
 Spiralwinkel: 5°

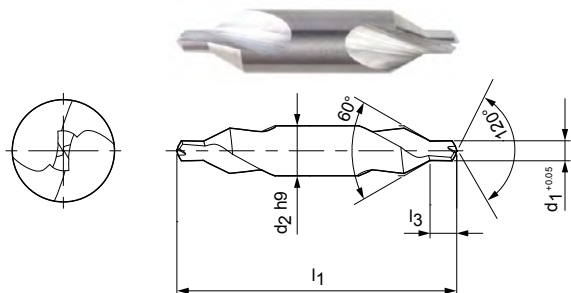

## Lagerhaltige Vorzugsbaureihe

Baumaße				Spezifikation	Bestell-Nr.
$d_1$ (0   +0,05)	$d_2$ h9	$l_1$	$l_3$		
0,50*	3,15	20	0,8	M1200-0050AU	30050399
0,80*	3,15	20	1,1	M1200-0080AU	30050402
1,00	3,15	31,5	1,3	M1200-0100AU	30050405
1,25	3,15	31,5	1,6	M1200-0125AU	30050407
1,60	4	35,5	2	M1200-0160AU	30050410
2,00	5	40	2,5	M1200-0200AU	30050413
2,50	6,3	45	3,1	M1200-0250AU	30050417

Maßangaben in mm.

\* Einseitig schneidend.

Schnittwertempfehlung siehe Kapitelende.

Sonderausführungen und andere Beschichtungen auf Anfrage.



# Schnittwertempfehlung für Anbohrer

Vorschub und Schnittgeschwindigkeit

## Tritan-Spot-Drill-Steel | M9930

MZG*	Werkstoff	Festigkeit/Härte [N/mm <sup>2</sup> ] [HRC]
P	P1.1 Bau-, Automaten-, Einsatz- und Vergütungsstähle, unlegiert	< 700
	P1.2 Bau-, Automaten-, Einsatz- und Vergütungsstähle, unlegiert	< 1.200
	P2.1 Nitrier-, Einsatz- und Vergütungsstähle, legiert	< 900
	P2.2 Nitrier-, Einsatz- und Vergütungsstähle, legiert	< 1.400
	P3.1 Werkzeug-, Wälzlager-, Feder- und Schnellarbeitsstähle**	< 800
	P3.2 Werkzeug-, Wälzlager-, Feder- und Schnellarbeitsstähle**	< 1.000
	P3.3 Werkzeug-, Wälzlager-, Feder- und Schnellarbeitsstähle**	< 1.500
	P5.1 Stahlguss	
M	M1.1 Rostfreie Stähle, austenitisch	< 700
	M1.2 Rostfreie Stähle, ferritisch/austenitisch (Duplex)	< 1.000
	M2.1 Rostfreier Stahlguss, austenitisch	< 700
	M3.1 Rostfreier Stahlguss, ferritisch/austenitisch (Duplex)	< 1.000
K	K1.1 Gusseisen mit Lamellengraphit (Grauguss), GJL	< 300
	K2.1 Gusseisen mit Kugelgraphit, GJS	< 500
	K2.2 Gusseisen mit Kugelgraphit, GJS	≤ 800
	K2.3 Gusseisen mit Kugelgraphit, GJS	> 800
	K3.1 Gusseisen mit Vermiculargraphit, GJV; Temperguss, GJM	< 500
	K3.2 Gusseisen mit Vermiculargraphit, GJV; Temperguss, GJM	> 500
N	N1.1 Aluminium, unlegiert und legiert < 3 % Si	
	N1.2 Aluminium, legiert ≤ 7 % Si	
	N1.3 Aluminium, legiert > 7-12 % Si	
	N1.4 Aluminium, legiert > 12 % Si	
	N2.1 Kupfer, unlegiert und niedriglegiert	< 300
	N2.2 Kupfer, legiert	> 300
	N2.3 Messing, Bronze, Rotguss	< 1.200
	N4.1 Kunststoff, Thermoplaste	
	N4.2 Kunststoff, Duroplaste	
	N4.3 Kunststoff, Schaumstoffe	
S	S1.1 Titan, Titanlegierungen	< 400
	S2.1 Titan, Titanlegierungen	< 1.200
	S2.2 Titan, Titanlegierungen	> 1.200
	S3.1 Nickel, unlegiert und legiert	< 900
	S3.2 Nickel, unlegiert und legiert	> 900
	S4.1 Hochwarmfeste Superlegierung, Ni-, Co-, und Fe-basiert	
	S5.1 Wolfram- und Molybdänlegierungen	
H	H1.1 Gehärteter Stahl/Stahlguss	< 44
	H1.2 Gehärteter Stahl/Stahlguss	< 55

\* MILLER Zerspanungsgruppen

\*\* Wenn die Legierungsbestandteile Cr, Mo, Ni, V, W in Summe > 8 %, dann die nächst höhere MILLER Zerspanungsgruppe wählen.

	Schnittgeschwindigkeit $v_c$ [m/min]				Vorschub $f$ [mm] bei Bohrerdurchmesser					
	Innenkühlung	Außenkühlung	MMS	Luft	4,00	5,50	7,50	10,50	14,50	20,00
	<b>175</b>	<b>160</b>	<b>160</b>		0,09	0,10	0,11	0,13	0,14	0,15
	<b>160</b>	<b>130</b>	<b>130</b>		0,11	0,12	0,14	0,16	0,17	0,18
	<b>170</b>	<b>145</b>	<b>145</b>		0,10	0,12	0,13	0,15	0,16	0,17
	<b>120</b>	<b>100</b>	<b>100</b>		0,08	0,09	0,11	0,12	0,13	0,14
	<b>110</b>	<b>95</b>	<b>95</b>		0,09	0,11	0,12	0,13	0,15	0,16
	<b>90</b>	<b>85</b>	<b>85</b>		0,08	0,09	0,10	0,11	0,12	0,13
	<b>90</b>	<b>70</b>	<b>75</b>		0,06	0,07	0,08	0,08	0,09	0,10
	<b>110</b>	<b>95</b>	<b>95</b>		0,10	0,12	0,13	0,15	0,16	0,17
	<b>70</b>	<b>45</b>	<b>45</b>		0,06	0,07	0,08	0,09	0,10	0,10
	<b>75</b>	<b>50</b>	<b>50</b>		0,06	0,07	0,08	0,09	0,10	0,10
	<b>245</b>	<b>175</b>	<b>175</b>	<b>175</b>	0,17	0,19	0,22	0,25	0,27	0,30
	<b>225</b>	<b>140</b>	<b>170</b>	<b>170</b>	0,16	0,18	0,20	0,23	0,25	0,27
	<b>170</b>	<b>130</b>	<b>130</b>		0,14	0,15	0,18	0,20	0,22	0,23
	<b>100</b>	<b>70</b>	<b>85</b>		0,09	0,10	0,12	0,13	0,14	0,15
	<b>155</b>	<b>135</b>	<b>135</b>		0,15	0,17	0,19	0,21	0,23	0,25
	<b>135</b>	<b>120</b>	<b>120</b>		0,12	0,13	0,15	0,17	0,19	0,20
	<b>300</b>	<b>200</b>	<b>250</b>		0,11	0,12	0,13	0,15	0,17	0,18
	<b>250</b>	<b>180</b>	<b>200</b>		0,14	0,15	0,18	0,20	0,22	0,23
	<b>220</b>	<b>150</b>	<b>180</b>		0,14	0,15	0,18	0,20	0,22	0,23
	<b>180</b>	<b>120</b>	<b>150</b>		0,14	0,15	0,18	0,20	0,22	0,23
	<b>140</b>	<b>100</b>			0,11	0,12	0,13	0,15	0,17	0,18
	<b>120</b>	<b>90</b>			0,14	0,15	0,18	0,20	0,22	0,23
	<b>200</b>	<b>160</b>	<b>160</b>	<b>120</b>	0,17	0,19	0,22	0,25	0,27	0,30
		<b>60</b>		<b>50</b>	0,09	0,10	0,12	0,13	0,14	0,15
		<b>65</b>		<b>40</b>	0,07	0,08	0,09	0,11	0,12	0,12
				<b>400</b>	0,07	0,08	0,09	0,11	0,12	0,12
	<b>40</b>	<b>25</b>			0,062	0,069	0,078	0,088	0,097	0,104
	<b>30</b>	<b>20</b>			0,053	0,059	0,067	0,075	0,083	0,089
	<b>25</b>	<b>15</b>			0,044	0,050	0,056	0,063	0,069	0,074
	<b>20</b>	<b>15</b>			0,035	0,040	0,045	0,050	0,055	0,059
	<b>15</b>	<b>10</b>			0,044	0,050	0,056	0,063	0,069	0,074
	<b>15</b>	<b>10</b>			0,035	0,040	0,045	0,050	0,055	0,059
	<b>15</b>	<b>10</b>			0,035	0,040	0,045	0,050	0,055	0,059
	<b>80</b>	<b>80</b>	<b>80</b>		0,078	0,087	0,098	0,109	0,120	0,128
	<b>30</b>	<b>30</b>	<b>30</b>		0,053	0,059	0,067	0,075	0,083	0,089

Die angegebenen Schnittwerte sind Richtwerte.

Die für den jeweiligen Bearbeitungsfall optimalen Daten sollten im Versuch oder während der Bearbeitung ermittelt werden.

# Schnittwertempfehlung für Anbohrer

Vorschub und Schnittgeschwindigkeit

## ECU-Centre-Drill | M1200

MZG*	Werkstoff	Festigkeit/Härte [N/mm <sup>2</sup> ] [HRC]
P	P1.1 Bau-, Automaten-, Einsatz- und Vergütungsstähle, unlegiert	< 700
	P1.2 Bau-, Automaten-, Einsatz- und Vergütungsstähle, unlegiert	< 1.200
	P2.1 Nitrier-, Einsatz- und Vergütungsstähle, legiert	< 900
	P2.2 Nitrier-, Einsatz- und Vergütungsstähle, legiert	< 1.400
	P3.1 Werkzeug-, Wälzlager-, Feder- und Schnellarbeitsstähle**	< 800
	P3.2 Werkzeug-, Wälzlager-, Feder- und Schnellarbeitsstähle**	< 1.000
	P3.3 Werkzeug-, Wälzlager-, Feder- und Schnellarbeitsstähle**	< 1.500
	P4.1 Rostfreie Stähle, ferritisch und martensitisch	
	P5.1 Stahlguss	
	P6.1 Rostfreier Stahlguss, ferritisch und martensitisch	
M	M1.1 Rostfreie Stähle, austenitisch	< 700
	M1.2 Rostfreie Stähle, ferritisch/austenitisch (Duplex)	< 1.000
	M2.1 Rostfreier Stahlguss, austenitisch	< 700
M3.1 Rostfreier Stahlguss, ferritisch/austenitisch (Duplex)	< 1.000	
N	N2.1 Kupfer, unlegiert und niedriglegiert	< 300
	N2.2 Kupfer, legiert	> 300
	N2.3 Messing, Bronze, Rotguss	< 1.200
S	S1.1 Titan, Titanlegierungen	< 400
	S2.1 Titan, Titanlegierungen	< 1.200
	S2.2 Titan, Titanlegierungen	> 1.200
	S3.1 Nickel, unlegiert und legiert	< 900
	S3.2 Nickel, unlegiert und legiert	> 900
S4.1 Hochwarmfeste Superlegierung, Ni-, Co-, und Fe-basiert		
S5.1 Wolfram- und Molybdänlegierungen		

\* MILLER Zerspanungsgruppen

\*\* Wenn die Legierungsbestandteile Cr, Mo, Ni, V, W in Summe > 8 %, dann die nächst höhere MILLER Zerspanungsgruppe wählen.

	Schnittgeschwindigkeit $v_c$ [m/min]				Vorschub $f$ [mm] bei Bohrerdurchmesser					
	Innenkühlung	Außenkühlung	MMS	Luft	0,50	0,83	1,38	2,29	3,80	6,30
		<b>70</b>	<b>70</b>		0,01	0,01	0,02	0,02	0,03	0,04
		<b>55</b>	<b>55</b>		0,01	0,02	0,02	0,03	0,04	0,06
		<b>65</b>	<b>65</b>		0,01	0,01	0,02	0,03	0,04	0,05
		<b>45</b>	<b>45</b>		0,01	0,01	0,02	0,02	0,03	0,04
		<b>50</b>	<b>50</b>		0,01	0,01	0,02	0,02	0,03	0,05
		<b>40</b>	<b>40</b>		0,01	0,01	0,02	0,02	0,03	0,04
		<b>35</b>	<b>40</b>		0,01	0,01	0,01	0,02	0,02	0,03
		<b>35</b>	<b>40</b>		0,01	0,01	0,01	0,02	0,02	0,03
		<b>65</b>	<b>65</b>		0,01	0,01	0,02	0,03	0,04	0,05
		<b>35</b>	<b>40</b>		0,01	0,01	0,01	0,02	0,02	0,03
		<b>30</b>	<b>30</b>		0,01	0,01	0,01	0,02	0,02	0,03
		<b>25</b>	<b>25</b>		0,01	0,01	0,01	0,01	0,02	0,03
		<b>30</b>	<b>30</b>		0,01	0,01	0,01	0,02	0,02	0,03
		<b>25</b>	<b>25</b>		0,01	0,01	0,01	0,01	0,02	0,03
		<b>85</b>			0,01	0,01	0,02	0,02	0,03	0,04
		<b>75</b>			0,01	0,01	0,02	0,03	0,04	0,06
		<b>135</b>	<b>135</b>		0,01	0,01	0,02	0,03	0,04	0,07
		<b>40</b>	<b>40</b>		0,01	0,01	0,02	0,02	0,03	0,04
		<b>35</b>	<b>35</b>		0,01	0,01	0,02	0,02	0,03	0,04
		<b>30</b>	<b>30</b>		0,01	0,01	0,02	0,02	0,03	0,04
		<b>25</b>	<b>25</b>		0,01	0,01	0,02	0,02	0,03	0,04
		<b>20</b>	<b>20</b>		0,01	0,01	0,02	0,02	0,03	0,04
		<b>20</b>	<b>20</b>		0,01	0,01	0,02	0,02	0,03	0,04
	<b>20</b>	<b>20</b>		0,01	0,01	0,02	0,02	0,03	0,04	

Die angegebenen Schnittwerte sind Richtwerte.

Die für den jeweiligen Bearbeitungsfall optimalen Daten sollten im Versuch oder während der Bearbeitung ermittelt werden.





# STUFENBOHREN

## Stufenbohrer

---

Tritan-Step-Drill-Steel ..... 266

MEGA-Step-Drill-Steel-Plus ..... 268

## Technischer Anhang

---

Schnittwertempfehlung ..... 270

# Tritan-Step-Drill-Steel

Vollhartmetall-Stufenbohrer  
M9913, innere Kühlmittelzufuhr

**Ausführung:**  
Bohrerdurchmesser: 3,98 - 17,50 mm  
Bohrungstoleranz: IT 9 (erreichbar)  
Beschichtung: MxP  
Schneidenanzahl: 3  
Anzahl Führungsfasen: 3  
Spitzenwinkel: 145°  
Spiralwinkel: 30°

**Anwendung:**  
Für Gewinde-Kernlochbohrung mit Ansenkung 90°.

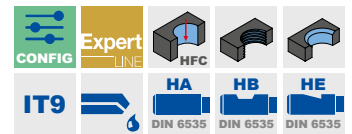
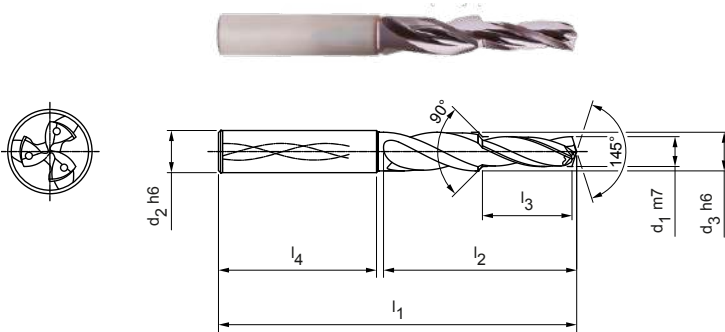

## Lagerhaltige Vorzugsbaureihe in Schaftform HA

Baumaße								Schaftform HA	
Für Gewinde	d <sub>1</sub> m7	d <sub>2</sub> h6	d <sub>3</sub> h6	l <sub>1</sub>	l <sub>2</sub>	l <sub>3</sub>	l <sub>4</sub>	Spezifikation	Bestell-Nr.
M5	4,25	6	5,5	66	28	13,6	36	M9913-0425AR	31049914
M6	5,10	8	6,6	79	41	16,5	36	M9913-0510AR	31049917
M8	6,85	10	8,8	89	47	21	40	M9913-0685AR	31049918
M8x1	7,10	10	8,8	89	47	21	40	M9913-0710AR	31067858
M10	8,60	12	11	102	55	25,5	45	M9913-0860AR	31049919
M10x1	9,10	12	11	102	55	25,5	45	M9913-0910AR	31067873
M12	10,35	14	13,2	107	60	30	45	M9913-1035AR	31049921
M16	14,15	18	17,6	123	73	38,5	48	M9913-1415AR	31049922

## Konfigurierbare Merkmale



**Durchmesser:**  
Durchmesser in Abstufungen von 0,01 mm frei wählbar



**Stufenlänge:**  
Stufenlänge in Abstufungen von 0,01 mm frei wählbar



**Schaftform:**  
Schaftform: HB | HE

**Spezifikation:**  
M9913-[Durchmesser][Schaftform]R

**Beispiel:**  
M9913-0431ER

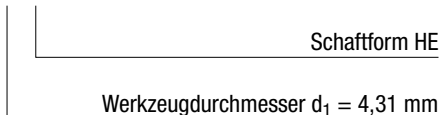

Maßangaben in mm.  
Schnittwertempfehlung siehe Kapitelende.  
Sonderausführungen und andere Beschichtungen auf Anfrage.

## Abmessungen konfigurierbare Baureihe

d <sub>1</sub> min.	d <sub>1</sub> max.	d <sub>2</sub> h6	d <sub>3</sub> h6	l <sub>1</sub>	l <sub>2</sub>	l <sub>3</sub> min.	l <sub>3</sub> max.
3,98	4,50	6	5	66	28	4,00	15,4
4,51	5,50	6	6	66	28	4,50	15,4
5,51	6,50	8	7	79	41	5,50	22,55
6,51	7,50	8	8	79	41	6,50	22,55
7,51	8,50	10	9	89	47	7,50	25,85
8,51	9,50	10	10	89	47	8,50	25,85
9,51	11,50	12	12	102	55	9,50	30,25
11,51	13,50	14	14	107	60	11,50	33
13,51	15,50	16	16	115	65	13,50	35,75
15,51	17,50	18	18	123	73	15,50	40,15

## Kernlochbohrungen mit 90°-Fase

nach DIN 8378 mit dem Tritan-Step-Drill-Steel



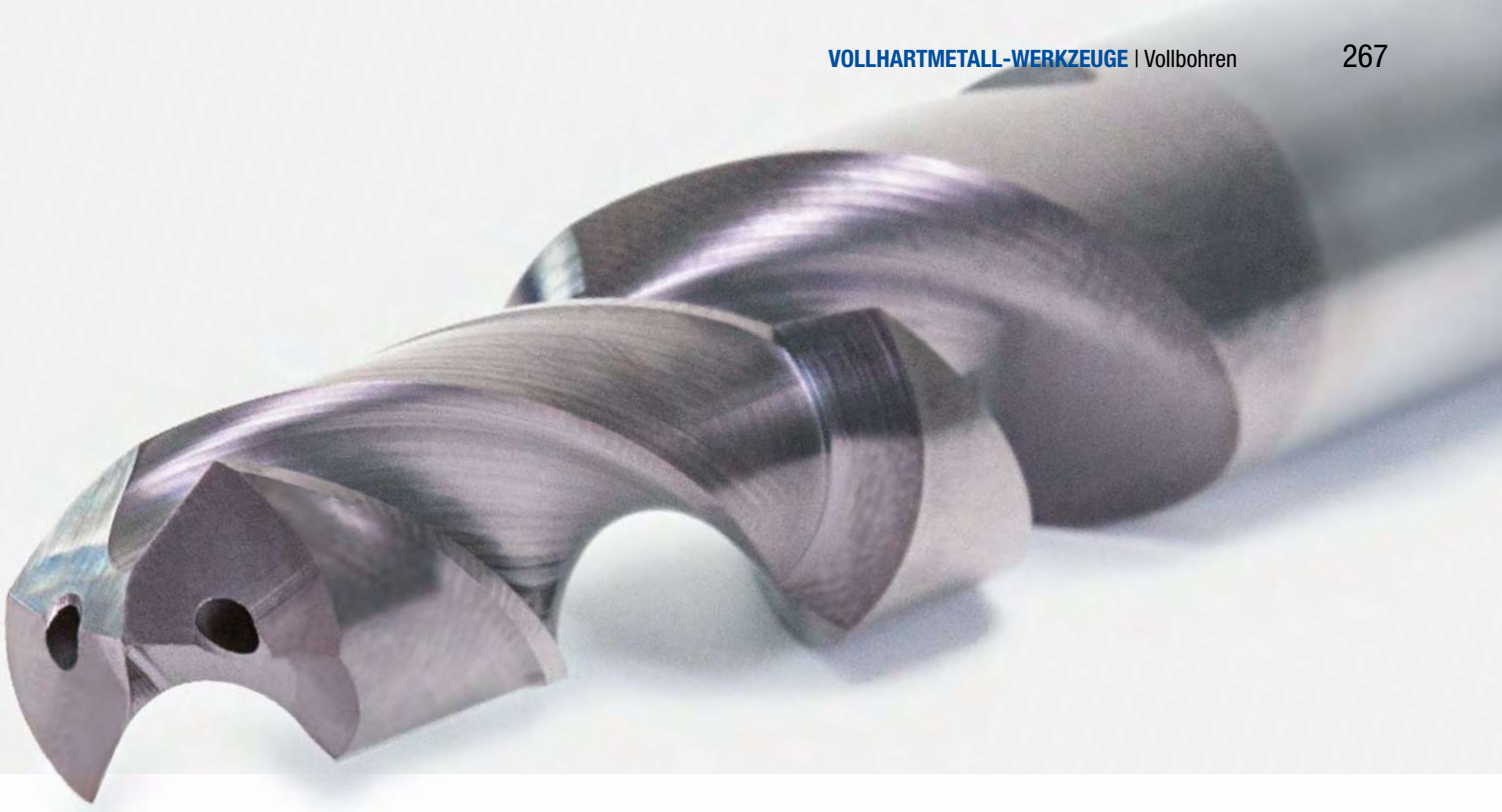

# MEGA-STEP-DRILL-STEEL-PLUS

Wirtschaftliche Bearbeitung von Gewindekernlöchern (nach DIN 8378)

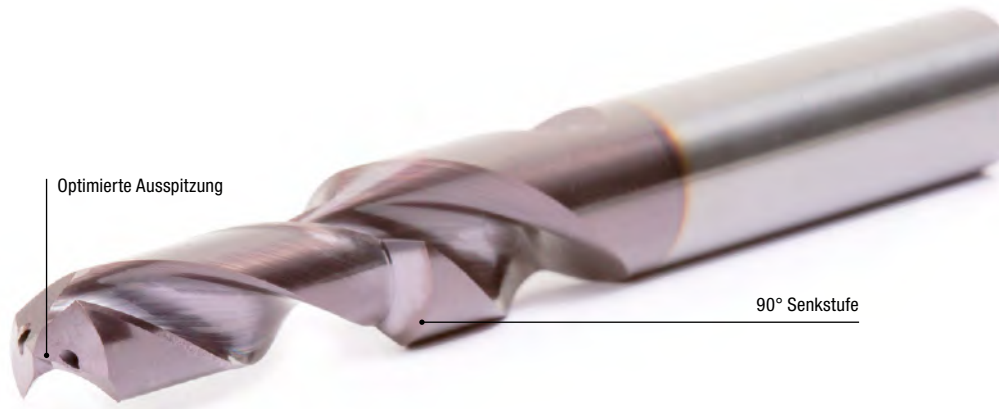
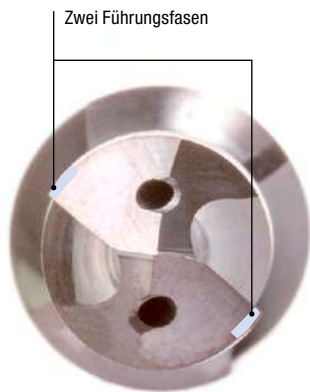

## Kernlochbohrung M10

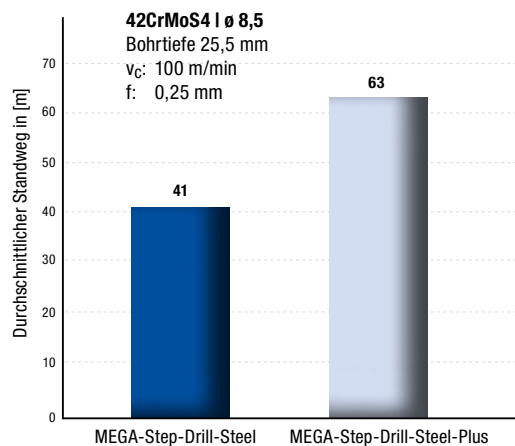
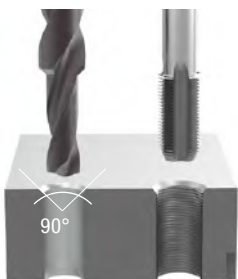

### AUF EINEN BLICK

- Upgrade des MEGA-Step-Drill-Steel mit und ohne IK
- Innovative Beschichtung
- Optimierte Mikro- und Makrogeometrie
- Durchmesserbereich von 2,50 bis 15,00 mm

### VORTEILE

- 15 Prozent höhere Schnittgeschwindigkeit\*
- 15 Prozent höherer Vorschub\*
- 50 Prozent höhere Standzeit\*

\* Im Vergleich zum Vorgängermodell

# MEGA-Step-Drill-Steel-Plus

Vollhartmetall-Stufenbohrer

M2303P, äußere Kühlmittelzufuhr, Nachfolgeprodukt des MEGA-Step-Drill-Steel

**Ausführung:**

Bohrerdurchmesser: 2,50 - 14,00 mm  
 Beschichtung: MxP  
 Schneidanzahl: 2  
 Anzahl Führungsfasen: 2  
 Spitzenwinkel: 140°  
 Spiralwinkel: 30°

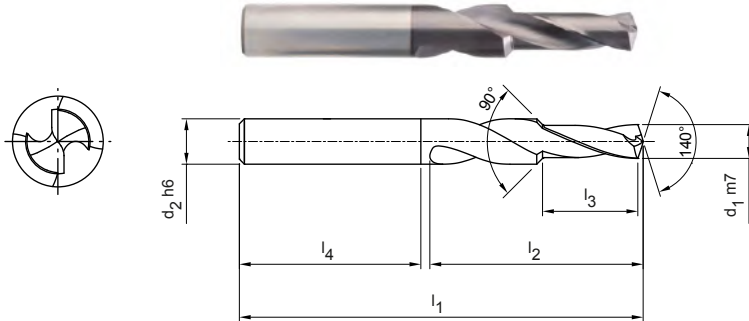

**Lagerhaltige Vorzugsbaureihe in Schaftform HA**

Baumaße								Schaftform HA	
Für Gewinde	Art	d <sub>1</sub> m7	d <sub>2</sub> h6	l <sub>1</sub>	l <sub>2</sub>	l <sub>3</sub>	l <sub>4</sub>	Spezifikation	Bestell-Nr.
M3	GB	2,50	6	62	20	8,8	36	M2303P-0250AR	31005238
M3	F0	2,80	6	62	20	8,8	36	M2303P-0280AR	31005239
M4	GB	3,30	6	62	24	11,4	36	M2303P-0330AR	31005240
M4	F0	3,70	6	62	24	11,4	36	M2303P-0370AR	31005241
M5	GB	4,20	6	66	28	13,6	36	M2303P-0420AR	31005242
M5	F0	4,65	6	66	28	13,6	36	M2303P-0465AR	31005243
M6	GB	5,00	8	79	34	16,5	36	M2303P-0500AR	31005244
M6	F0	5,55	8	79	34	16,5	36	M2303P-0555AR	31005245
M8	GB	6,80	10	89	47	21	40	M2303P-0680AR	31005246
M8	F0	7,45	10	89	47	21	40	M2303P-0745AR	31005247
M10	GB	8,50	12	102	55	25,5	45	M2303P-0850AR	31005248
M10	F0	9,30	12	102	55	25,5	45	M2303P-0930AR	31005249
M12	GB	10,20	14	107	60	30	45	M2303P-1020AR	31005250
M12	F0	11,20	14	107	60	30	45	M2303P-1120AR	31005251
M14	GB	12,00	16	115	65	34,5	48	M2303P-1200AR	31008421
M16	GB	14,00	18	123	73	38,5	48	M2303P-1400AR	31005252

GB: Kernloch Gewindebohren | F0: Kernloch Gewindeformen / Gewindefurchen

**Konfigurierbare Merkmale**



**Schaftform:**  
Schaftform: HB | HE



**Spezifikation:**  
M2303P-0555[**Schaftform**]R

**Beispiel:**  
M2303P-0555ER

Schaftform HE

Maßangaben in mm.

Schnittwertempfehlung siehe Kapitelende.

Sonderausführungen und andere Beschichtungen auf Anfrage.

# MEGA-Step-Drill-Steel-Plus

Vollhartmetall-Stufenbohrer

M2403P, innere Kühlmittelzufuhr, Nachfolgeprodukt des MEGA-Step-Drill-Steel

**Ausführung:**

Bohrerdurchmesser: 3,30 - 14,00 mm  
 Beschichtung: MxP  
 Schneidenanzahl: 2  
 Anzahl Führungsfasen: 2  
 Spitzenwinkel: 140°  
 Spiralwinkel: 30°

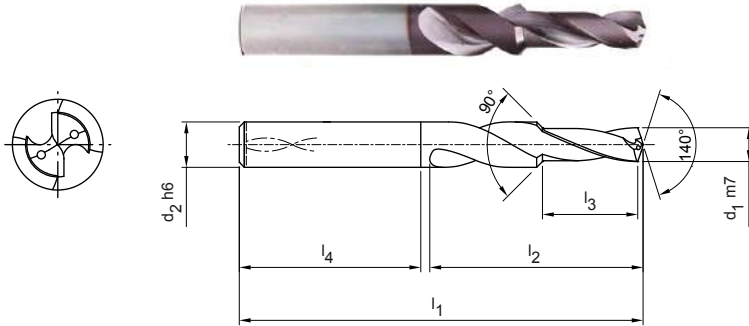

**Lagerhaltige Vorzugsbaureihe in Schaftform HA**

Baumaße								Schaftform HA	
Für Gewinde	Art	d <sub>1</sub> m7	d <sub>2</sub> h6	l <sub>1</sub>	l <sub>2</sub>	l <sub>3</sub>	l <sub>4</sub>	Spezifikation	Bestell-Nr.
M4	GB	3,30	6	62	24	11,4	36	M2403P-0330AR	31140974
M4	F0	3,70	6	62	24	11,4	36	M2403P-0370AR	31140975
M5	GB	4,20	6	66	28	13,6	36	M2403P-0420AR	31140976
M6	GB	5,00	8	79	34	16,5	36	M2403P-0500AR	31140978
M6	F0	5,55	8	79	34	16,5	36	M2403P-0555AR	31140979
M8	GB	6,80	10	89	47	21	40	M2403P-0680AR	31141000
M8	F0	7,45	10	89	47	21	40	M2403P-0745AR	31141001
M10	GB	8,50	12	102	55	25,5	45	M2403P-0850AR	31141002
M10	F0	9,30	12	102	55	25,5	45	M2403P-0930AR	31141003
M12	GB	10,20	14	107	60	30	45	M2403P-1020AR	31141004
M12	GB	10,20	14	107	60	30	45	M2403P-1020AR	31141004

**Auf Anfrage erhältlich**

M12	F0	11,20	14	107	60	30	45	M2403P-1120AR	31141005
M16	GB	14,00	18	123	73	38,5	48	M2403P-1400AR	31141006

GB: Kernloch Gewindebohren | F0: Kernloch Gewindeformen / Gewindefurchen

**Konfigurierbare Merkmale**



**Schaftform:**  
Schaftform: HB | HE



**Spezifikation:**  
M2403P-0555[**Schaftform**]R

**Beispiel:**  
M2403P-0555ER

Schaftform HE

Maßangaben in mm.

Schnittwertempfehlung siehe Kapitelende.

Sonderausführungen und andere Beschichtungen auf Anfrage.

# Schnittwertempfehlung für Stufenbohrer

Vorschub und Schnittgeschwindigkeit

## Tritan-Step-Drill-Steel | M9913

MZG*	Werkstoff	Festigkeit/Härte [N/mm <sup>2</sup> ] [HRC]
P	P1.1 Bau-, Automaten-, Einsatz- und Vergütungsstähle, unlegiert	< 700
	P1.2 Bau-, Automaten-, Einsatz- und Vergütungsstähle, unlegiert	< 1.200
	P2.1 Nitrier-, Einsatz- und Vergütungsstähle, legiert	< 900
	P2.2 Nitrier-, Einsatz- und Vergütungsstähle, legiert	< 1.400
	P3.1 Werkzeug-, Wälzlager-, Feder- und Schnellarbeitsstähle**	< 800
	P3.2 Werkzeug-, Wälzlager-, Feder- und Schnellarbeitsstähle**	< 1.000
	P3.3 Werkzeug-, Wälzlager-, Feder- und Schnellarbeitsstähle**	< 1.500
	P5.1 Stahlguss	
M	M1.1 Rostfreie Stähle, austenitisch	< 700
	M1.2 Rostfreie Stähle, ferritisch/austenitisch (Duplex)	< 1.000
K	K1.1 Gusseisen mit Lamellengraphit (Grauguss), GJL	< 300
	K2.1 Gusseisen mit Kugelgraphit, GJS	< 500
	K2.2 Gusseisen mit Kugelgraphit, GJS	≤ 800
	K2.3 Gusseisen mit Kugelgraphit, GJS	> 800
	K3.1 Gusseisen mit Vermiculargraphit, GJV; Temperguss, GJM	< 500
	K3.2 Gusseisen mit Vermiculargraphit, GJV; Temperguss, GJM	> 500

\* MILLER Zerspanungsgruppen

\*\* Wenn die Legierungsbestandteile Cr, Mo, Ni, V, W in Summe > 8 %, dann die nächst höhere MILLER Zerspanungsgruppe wählen.

	Schnittgeschwindigkeit $v_c$ [m/min]				Vorschub $f$ [mm] bei Bohrerdurchmesser					
	Innenkühlung	Außenkühlung	MMS	Luft	4,00	5,50	7,50	10,50	14,50	20,00
	<b>115</b>	<b>105</b>	<b>105</b>		0,24	0,30	0,37	0,46	0,56	0,65
	<b>105</b>	<b>85</b>	<b>85</b>		0,30	0,37	0,46	0,58	0,70	0,81
	<b>115</b>	<b>100</b>	<b>100</b>		0,28	0,35	0,44	0,55	0,66	0,77
	<b>80</b>	<b>70</b>	<b>70</b>		0,24	0,29	0,36	0,44	0,53	0,61
	<b>85</b>	<b>75</b>	<b>75</b>		0,25	0,31	0,39	0,49	0,60	0,69
	<b>70</b>	<b>65</b>	<b>65</b>		0,21	0,26	0,33	0,41	0,49	0,56
	<b>70</b>	<b>50</b>	<b>60</b>		0,18	0,21	0,26	0,32	0,38	0,43
	<b>115</b>	<b>100</b>	<b>100</b>		0,28	0,35	0,44	0,55	0,66	0,77
	<b>55</b>	<b>35</b>	<b>35</b>		0,11	0,14	0,18	0,22	0,27	0,31
	<b>140</b>	<b>100</b>	<b>100</b>	<b>100</b>	0,36	0,45	0,55	0,67	0,80	0,91
	<b>185</b>	<b>115</b>	<b>140</b>	<b>140</b>	0,35	0,43	0,52	0,63	0,74	0,84
	<b>115</b>	<b>85</b>	<b>85</b>		0,31	0,38	0,46	0,55	0,64	0,73
	<b>70</b>	<b>45</b>	<b>60</b>		0,17	0,20	0,24	0,28	0,33	0,37
	<b>105</b>	<b>90</b>	<b>90</b>		0,34	0,41	0,49	0,59	0,69	0,78
	<b>90</b>	<b>80</b>	<b>80</b>		0,28	0,34	0,40	0,47	0,55	0,62

Die angegebenen Schnittwerte sind Richtwerte.

Die für den jeweiligen Bearbeitungsfall optimalen Daten sollten im Versuch oder während der Bearbeitung ermittelt werden.

# Schnittwertempfehlung für Stufenbohrer

Vorschub und Schnittgeschwindigkeit

## MEGA-Step-Drill-Steel-Plus I M2303P, M2403P

MZG*	Werkstoff	Festigkeit/Härte [N/mm <sup>2</sup> ] [HRC]
P	P1.1 Bau-, Automaten-, Einsatz- und Vergütungsstähle, unlegiert	< 700
	P1.2 Bau-, Automaten-, Einsatz- und Vergütungsstähle, unlegiert	< 1.200
	P2.1 Nitrier-, Einsatz- und Vergütungsstähle, legiert	< 900
	P2.2 Nitrier-, Einsatz- und Vergütungsstähle, legiert	< 1.400
	P3.1 Werkzeug-, Wälzlager-, Feder- und Schnellarbeitsstähle**	< 800
	P3.2 Werkzeug-, Wälzlager-, Feder- und Schnellarbeitsstähle**	< 1.000
	P3.3 Werkzeug-, Wälzlager-, Feder- und Schnellarbeitsstähle**	< 1.500
	P4.1 Rostfreie Stähle, ferritisch und martensitisch	
	P5.1 Stahlguss	
	P6.1 Rostfreier Stahlguss, ferritisch und martensitisch	
	K	K1.1 Gusseisen mit Lamellengraphit (Grauguss), GJL
K2.1 Gusseisen mit Kugelgraphit, GJS		< 500
K2.2 Gusseisen mit Kugelgraphit, GJS		≤ 800
K2.3 Gusseisen mit Kugelgraphit, GJS		> 800
K3.1 Gusseisen mit Vermiculargraphit, GJV; Temperguss, GJM		< 500
K3.2 Gusseisen mit Vermiculargraphit, GJV; Temperguss, GJM		> 500
H	H1.1 Gehärteter Stahl/Stahlguss	< 44
	H1.2 Gehärteter Stahl/Stahlguss	< 55

\* MILLER Zerspanungsgruppen

\*\* Wenn die Legierungsbestandteile Cr, Mo, Ni, V, W in Summe > 8 %, dann die nächst höhere MILLER Zerspanungsgruppe wählen.



	Schnittgeschwindigkeit $v_c$ [m/min]				Vorschub $f$ [mm] bei Bohrerdurchmesser					
	Innenkühlung	Außenkühlung	MMS	Luft	2,50	3,70	5,00	7,45	10,20	15,00
	<b>110</b>	<b>100</b>	<b>100</b>		0,09	0,11	0,14	0,18	0,23	0,29
	<b>100</b>	<b>85</b>	<b>85</b>		0,11	0,14	0,18	0,23	0,29	0,36
	<b>110</b>	<b>95</b>	<b>95</b>		0,10	0,13	0,17	0,22	0,27	0,34
	<b>75</b>	<b>65</b>	<b>65</b>		0,09	0,11	0,14	0,18	0,22	0,27
	<b>85</b>	<b>70</b>	<b>70</b>		0,09	0,11	0,15	0,19	0,25	0,30
	<b>65</b>	<b>60</b>	<b>60</b>		0,08	0,10	0,13	0,16	0,20	0,25
	<b>65</b>	<b>50</b>	<b>55</b>		0,07	0,08	0,10	0,13	0,16	0,19
	<b>65</b>	<b>50</b>	<b>55</b>		0,06	0,08	0,10	0,13	0,16	0,20
	<b>110</b>	<b>95</b>	<b>95</b>		0,10	0,13	0,17	0,22	0,27	0,34
	<b>65</b>	<b>50</b>	<b>55</b>		0,06	0,08	0,10	0,13	0,16	0,20
	<b>120</b>	<b>85</b>	<b>85</b>	<b>85</b>	0,13	0,19	0,26	0,35	0,45	0,54
	<b>160</b>	<b>100</b>	<b>120</b>	<b>120</b>	0,13	0,18	0,25	0,33	0,42	0,50
	<b>100</b>	<b>75</b>	<b>75</b>		0,12	0,16	0,22	0,28	0,36	0,43
	<b>60</b>	<b>40</b>	<b>50</b>		0,09	0,12	0,15	0,19	0,24	0,28
	<b>90</b>	<b>80</b>	<b>80</b>		0,13	0,18	0,23	0,31	0,39	0,46
	<b>80</b>	<b>70</b>	<b>70</b>		0,11	0,15	0,19	0,25	0,31	0,36
	<b>90</b>	<b>90</b>	<b>90</b>		0,08	0,10	0,13	0,16	0,20	0,25
	<b>25</b>	<b>25</b>	<b>25</b>		0,04	0,05	0,07	0,09	0,11	0,14

Die angegebenen Schnittwerte sind Richtwerte.

Die für den jeweiligen Bearbeitungsfall optimalen Daten sollten im Versuch oder während der Bearbeitung ermittelt werden.





# TIEFBOHREN

## Tiefbohrer

---

MEGA-Pilot-Drill .....	276
MEGA-Deep-Drill .....	277
MEGA-Deep-Drill-Alu .....	286

## Technischer Anhang

---

Schnittwertempfehlung .....	292
Anwendungshinweise Tiefbohrer .....	512

# MEGA-Pilot-Drill

Vollhartmetall-Stufenbohrer  
M2413, innere Kühlmittelzufuhr

## Ausführung:

Bohrerdurchmesser: 1,00 - 3,00 mm  
Bohrungstoleranz: IT 9 (erreichbar)  
Beschichtung: Mx15  
Schneidenanzahl: 2  
Anzahl Führungsfasen: 2  
Spitzenwinkel: 142°

## Anwendung:

Speziell auf den MEGA-Deep-Drill abgestimmter Pilotbohrer.  
Maximal einsetzbar bis Durchmesser 3,00 mm.

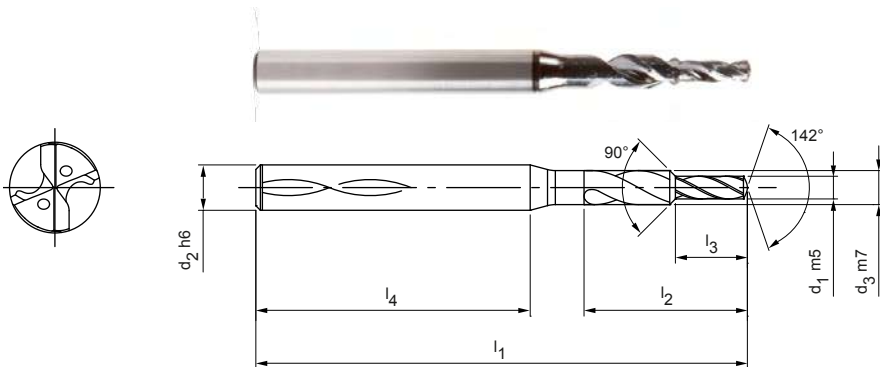

## Lagerhaltige Vorzugsbaureihe in Schaftform HA

Baumaße							Schaftform HA	
d <sub>1</sub> m5	d <sub>2</sub> h6	d <sub>3</sub> m7	l <sub>1</sub>	l <sub>2</sub>	l <sub>3</sub>	l <sub>4</sub>	Spezifikation	Bestell-Nr.
1,00	3	1,5	50	7,2	3	38	M2413-0100A04	31080891
1,10	3	1,65	50	7,9	3,3	37,5	M2413-0110A04	31080892
1,20	3	1,8	50	8,6	3,6	36,9	M2413-0120A04	31080893
1,30	3	1,95	50	9,4	3,9	36,3	M2413-0130A04	31080894
1,40	3	2,1	50	10,1	4,2	35,7	M2413-0140A04	31080895
1,50	3	2,25	50	10,8	4,5	35,1	M2413-0150A04	31080896
1,60	3	2,4	50	11,5	4,8	34,6	M2413-0160A04	31080897
1,70	3	2,55	50	12,2	5,1	34	M2413-0170A04	31080898
1,80	3	2,7	50	13	5,4	33,4	M2413-0180A04	31080899
1,90	4	2,85	55	13,7	5,7	35,9	M2413-0190A04	31080900
2,00	4	3	55	14,4	6	35,3	M2413-0200A04	31080901
2,10	4	3,15	55	15,1	6,3	34,8	M2413-0210A04	31080902
2,20	4	3,3	55	15,8	6,6	34,2	M2413-0220A04	31080903
2,30	4	3,45	55	16,6	6,9	33,6	M2413-0230A04	31080904
2,40	4	3,6	55	17,3	7,2	33	M2413-0240A04	31080905
2,50	4	3,75	55	18	7,5	32,4	M2413-0250A04	31080906
2,60	6	3,9	66	18,7	7,8	39,1	M2413-0260A04	31080907
2,70	6	4,05	66	19,4	8,1	38,5	M2413-0270A04	31080908
2,80	6	4,2	66	20,2	8,4	37,9	M2413-0280A04	31080909
2,90	6	4,35	66	20,9	8,7	37,4	M2413-0290A04	31080910
3,00	6	4,5	66	21,6	9	36,8	M2413-0300A04	31080911

Maßangaben in mm.

Schnittwertempfehlung siehe Kapitelende.

Sonderausführungen und andere Beschichtungen auf Anfrage.

# MEGA-Deep-Drill

Vollhartmetall-Tiefbohrer  
M2120 (20xD), innere Kühlmittelzufuhr

**Ausführung:**  
Bohrerdurchmesser: 1,00 - 2,99 mm  
Bohrungstoleranz:  $\geq$  IT 9  
Beschichtung: Mx15  
Schneidenanzahl: 2  
Anzahl Führungsfasen: 4  
Spitzenwinkel: 135°  
Spiralwinkel: 30°  
Besonderheiten: Kopfbeschichtung

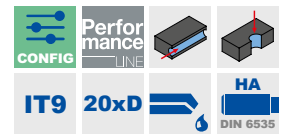
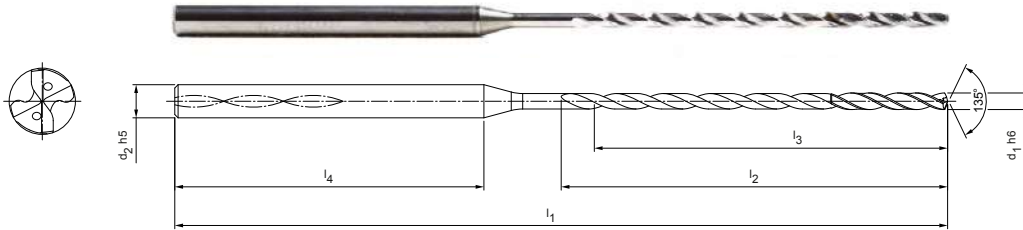

## Lagerhaltige Vorzugsbaureihe in Schaftform HA

Baumaße						L/d-Verhältnis	Schaftform HA	
d <sub>1</sub> h6	d <sub>2</sub> h5	l <sub>1</sub>	l <sub>2</sub>	l <sub>3</sub>	l <sub>4</sub>		Spezifikation	Bestell-Nr.
1,00	3	62	27	25	28	28	M2120-0100A04	30837343
1,10	3	62	27	25	28	28	M2120-0110A04	30837345
1,20	3	62	27	25	28	28	M2120-0120A04	30837346
1,30	3	70	35	33	28	28	M2120-0130A04	30837347
1,40	3	70	35	32	28	28	M2120-0140A04	30837348
1,50	3	70	35	32	28	28	M2120-0150A04	30837349
1,60	3	75	41	38	28	28	M2120-0160A04	30837350
1,70	3	75	41	38	28	28	M2120-0170A04	30837351
1,80	3	75	41	38	28	28	M2120-0180A04	30837352
1,90	3	80	46	43	28	28	M2120-0190A04	30837353
2,00	3	80	46	43	28	28	M2120-0200A04	30837354
2,10	3	80	46	42	28	28	M2120-0210A04	30837355
2,20	3	90	55	51	28	28	M2120-0220A04	30837356
2,30	3	90	55	51	28	28	M2120-0230A04	30837357
2,40	3	90	55	51	28	28	M2120-0240A04	30837358
2,50	3	90	55	51	28	28	M2120-0250A04	30837359
2,60	3	100	66	62	28	28	M2120-0260A04	30837360
2,70	3	100	66	61	28	28	M2120-0270A04	30837361
2,80	3	100	66	61	28	28	M2120-0280A04	30837362
2,90	3	100	66	61	28	28	M2120-0290A04	30837363

Fortsetzung auf nächster Seite.

### Empfehlung für Pilotbohrer:

Bitte verwenden Sie als Pilotbohrer den MEGA-Pilot-Drill (M2413) oder den MICRO-Drill-Steel (M1925 - 5xD) mit dem gleichen Nenndurchmesser. Spitzenwinkel und Durchmesser-toleranzen sind für eine optimale Funktionalität sowie auf das Zusammenspiel von Pilotbohrer und Tiefbohrer abgestimmt.

**MEGA-Deep-Drill | Vollhartmetall-Tiefbohrer M2120 (20xD), innere Kühlmittelzufuhr****Konfigurierbare Merkmale**

**Durchmesser:**  
Durchmesser in Abstufungen  
von 0,01 mm frei wählbar

**Spezifikation:**

M2120-[Durchmesser]A04

**Beispiel:**

M2120-0221A04

Werkzeugdurchmesser  $d_1 = 2,21$  mm

**Abmessungen konfigurierbare Baureihe**

$d_1$ min.	$d_1$ max.	$d_2$ h6	$l_1$	$l_2$	$l_3$	$l_4$
1,00	1,29	3	62	27	25	28
1,30	1,39	3	70	35	33	28
1,40	1,59	3	70	35	32	28
1,60	1,89	3	75	41	38	28
1,90	2,09	3	80	46	43	28
2,10	2,19	3	80	46	42	28
2,20	2,59	3	90	55	51	28
2,60	2,69	3	100	66	62	28
2,70	2,99	3	100	66	61	28

**Anwendungstechnische Hinweise zum Tiefbohren  
finden Sie im Kapitel Technischer Anhang.**

Maßangaben in mm.

Schnittwertempfehlung siehe Kapitelende.

Sonderausführungen und andere Beschichtungen auf Anfrage.

# MEGA-Deep-Drill

Vollhartmetall-Tiefbohrer  
M2130 (30xD), innere Kühlmittelzufuhr

**Ausführung:**  
Bohrerdurchmesser: 1,00 - 2,99 mm  
Bohrungstoleranz:  $\geq$  IT 9  
Beschichtung: Mx15  
Schneidenanzahl: 2  
Anzahl Führungsfasen: 4  
Spitzenwinkel: 135°  
Spiralwinkel: 30°  
Besonderheiten: Kopfbeschichtung

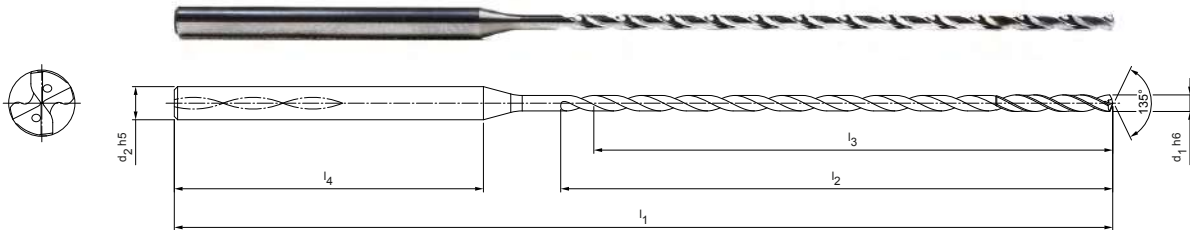

## Lagerhaltige Vorzugsbaureihe in Schaftform HA

Baumaße						L/d-Verhältnis	Schaftform HA	
d <sub>1</sub> h6	d <sub>2</sub> h5	l <sub>1</sub>	l <sub>2</sub>	l <sub>3</sub>	l <sub>4</sub>		Spezifikation	Bestell-Nr.
1,00	3	75	38	36	28	36	M2130-0100A04	30837364
1,10	3	75	38	36	28	33	M2130-0110A04	30837365
1,20	3	75	38	36	28	30	M2130-0120A04	30837366
1,30	3	85	50	48	28	37	M2130-0130A04	30837367
1,40	3	85	50	47	28	34	M2130-0140A04	30837368
1,50	3	85	50	47	28	31	M2130-0150A04	30837369
1,60	3	95	59	56	28	35	M2130-0160A04	30837370
1,70	3	95	59	56	28	33	M2130-0170A04	30837371
1,80	3	95	59	56	28	31	M2130-0180A04	30837372
1,90	3	100	66	63	28	33	M2130-0190A04	30837373
2,00	3	100	66	63	28	32	M2130-0200A04	30837374
2,10	3	100	66	62	28	30	M2130-0210A04	30837375
2,20	3	115	80	76	28	35	M2130-0220A04	30837376
2,30	3	115	80	76	28	33	M2130-0230A04	30837377
2,40	3	115	80	76	28	32	M2130-0240A04	30837378
2,50	3	115	80	76	28	30	M2130-0250A04	30224153
2,60	3	130	96	92	28	35	M2130-0260A04	30837379
2,70	3	130	96	91	28	34	M2130-0270A04	30837380
2,80	3	130	96	91	28	33	M2130-0280A04	30837381
2,90	3	130	96	91	28	31	M2130-0290A04	30837382

Fortsetzung auf nächster Seite.

### Empfehlung für Pilotbohrer:

Bitte verwenden Sie als Pilotbohrer den MEGA-Pilot-Drill (M2413) oder den MICRO-Drill-Steel (M1925 - 5xD) mit dem gleichen Nenndurchmesser. Spitzenwinkel und Durchmesser-toleranzen sind für eine optimale Funktionalität sowie auf das Zusammenspiel von Pilotbohrer und Tiefbohrer abgestimmt.

**MEGA-Deep-Drill | Vollhartmetall-Tiefbohrer M2130 (30xD), innere Kühlmittelzufuhr****Konfigurierbare Merkmale**

**Durchmesser:**  
Durchmesser in Abstufungen  
von 0,01 mm frei wählbar

**Spezifikation:**

M2130-[Durchmesser]A04

**Beispiel:**

M2130-0221A04

Werkzeugdurchmesser  $d_1 = 2,21$  mm**Abmessungen konfigurierbare Baureihe**

$d_1$ min.	$d_1$ max.	$d_2$ h6	$l_1$	$l_2$	$l_3$	$l_4$
1,00	1,29	3	75	38	36	28
1,30	1,39	3	85	50	48	28
1,40	1,59	3	85	50	47	28
1,60	1,89	3	95	59	56	28
1,90	2,09	3	100	66	63	28
2,10	2,19	3	100	66	62	28
2,20	2,59	3	115	80	76	28
2,60	2,69	3	130	96	92	28
2,70	2,99	3	130	96	91	28

**Anwendungstechnische Hinweise zum Tiefbohren  
finden Sie im Kapitel Technischer Anhang.**

Maßangaben in mm.

Schnittwertempfehlung siehe Kapitelende.

Sonderausführungen und andere Beschichtungen auf Anfrage.



# MEGA-Deep-Drill

Vollhartmetall-Tiefbohrer  
M2115 (15xD), innere Kühlmittelzufuhr

**Ausführung:**  
Bohrerdurchmesser: 3,00 - 15,00 mm  
Bohrungstoleranz:  $\geq$  IT 9  
Beschichtung: MxF  
Schneidenanzahl: 2  
Anzahl Führungsfasen: 4  
Spitzenwinkel: 135°  
Spiralwinkel: 30°

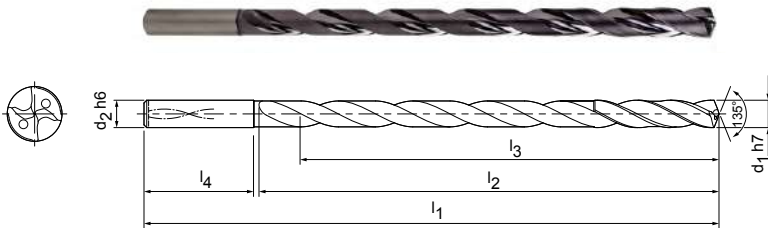

## Lagerhaltige Vorzugsbaureihe in Schaftform HA

Baumaße						L/d-Verhältnis	Schaftform HA	
d <sub>1</sub> h7	d <sub>2</sub> h6	l <sub>1</sub>	l <sub>2</sub>	l <sub>3</sub>	l <sub>4</sub>		Spezifikation	Bestell-Nr.
3,00	4	90	56	52	32	17	M2115-0300AE	30213695
3,50	4	100	66	61	32	17	M2115-0350AE	30213696
4,00	4	100	66	60	32	15	M2115-0400AE	30213697
4,50	5	110	74	67	34	15	M2115-0450AE	30213698
5,00	5	120	84	77	34	15	M2115-0500AE	30213699
5,50	6	130	92	84	36	15	M2115-0550AE	30213700
6,00	6	140	102	93	36	16	M2115-0600AE	30213701
7,00	7	155	115	105	38	15	M2115-0700AE	30213703
8,00	8	175	133	121	40	15	M2115-0800AE	30213705
9,00	9	190	148	135	40	15	M2115-0900AE	30213707
9,50	10	210	168	153	40	15	M2115-0950AE	30292428
10,00	10	210	168	153	40	15	M2115-1000AE	30213708
11,00	11	230	183	167	45	15	M2115-1100AE	30213709
12,00	12	250	203	185	45	15	M2115-1200AE	30213710
13,00	13	265	218	199	45	15	M2115-1300AE	30213711
14,00	14	285	233	212	50	15	M2115-1400AE	30213712
15,00	15	305	253	231	50	15	M2115-1500AE	30213713

### Empfehlung für Pilotbohrer:

Bitte verwenden Sie als Pilotbohrer für den MEGA-Drill-Steel-Plus (M2103P - 3xD) mit dem gleichen Nenndurchmesser.

Spitzenwinkel und Durchmesser toleranzen sind für eine optimale Funktionalität sowie auf das Zusammenspiel von Pilotbohrer und Tiefbohrer abgestimmt.

Anwendungstechnische Hinweise zum Tiefbohren finden Sie im Kapitel Technischer Anhang.

Maßangaben in mm.  
Schnittwertempfehlung siehe Kapitelende.  
Sonderausführungen und andere Beschichtungen auf Anfrage.

# MEGA-Deep-Drill

Vollhartmetall-Tiefbohrer  
M2120 (20xD), innere Kühlmittelzufuhr

**Ausführung:**

Bohrerdurchmesser: 3,00 - 16,00 mm  
Bohrungstoleranz:  $\geq$  IT 9  
Beschichtung: MxF  
Schneidenanzahl: 2  
Anzahl Führungsfasen: 4  
Spitzenwinkel: 135°  
Spiralwinkel: 30°

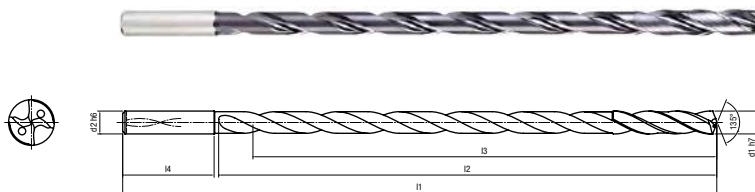

## Lagerhaltige Vorzugsbaureihe in Schaffform HA

Baumaße						L/d-Verhältnis	Schaffform HA	
d <sub>1</sub> h7	d <sub>2</sub> h6	l <sub>1</sub>	l <sub>2</sub>	l <sub>3</sub>	l <sub>4</sub>		Spezifikation	Bestell-Nr.
3,00	4	110	74	70	32	23	M2120-0300AE	30213715
3,50	4	120	86	81	32	23	M2120-0350AE	30213716
4,00	4	120	86	80	32	20	M2120-0400AE	30213717
5,00	5	145	109	102	34	20	M2120-0500AE	30213719
5,50	6	160	120	112	36	20	M2120-0550AE	30213720
6,00	6	170	130	121	36	20	M2120-0600AE	30213721
6,50	7	190	150	140	36	20	M2120-0650AE	30213722
7,00	7	190	150	140	38	20	M2120-0700AE	30213723
8,00	8	215	173	161	40	20	M2120-0800AE	30213725
9,00	9	240	196	183	40	20	M2120-0900AE	30213727
10,00	10	260	218	203	40	20	M2120-1000AE	30213728
11,00	11	285	238	222	45	20	M2120-1100AE	30213729
12,00	12	305	258	240	45	20	M2120-1200AE	30213730
14,00	14	355	303	282	50	20	M2120-1400AE	30213732
15,00	15	375	323	301	50	20	M2120-1500AE	30213733
16,00	16	400	348	324	50	20	M2120-1600AE	30213734

### Empfehlung für Pilotbohrer:

Bitte verwenden Sie als Pilotbohrer den MEGA-Drill-Steel-Plus (M2103P - 3xD) mit dem gleichen Nenndurchmesser.

Spitzenwinkel und Durchmesser toleranzen sind für eine optimale Funktionalität sowie auf das Zusammenspiel von Pilotbohrer und Tiefbohrer abgestimmt.

**Anwendungstechnische Hinweise zum Tiefbohren finden Sie im Kapitel Technischer Anhang.**

Maßangaben in mm.

Schnittwertempfehlung siehe Kapitelende.

Sonderausführungen und andere Beschichtungen auf Anfrage.

# MEGA-Deep-Drill

Vollhartmetall-Tiefbohrer  
M2125 (25xD), innere Kühlmittelzufuhr

**Ausführung:**

Bohrerdurchmesser: 3,00 - 14,00 mm  
Bohrungstoleranz:  $\geq$  IT 9  
Beschichtung: MxF  
Schneidenanzahl: 2  
Anzahl Führungsfasen: 4  
Spitzenwinkel: 135°  
Spiralwinkel: 30°

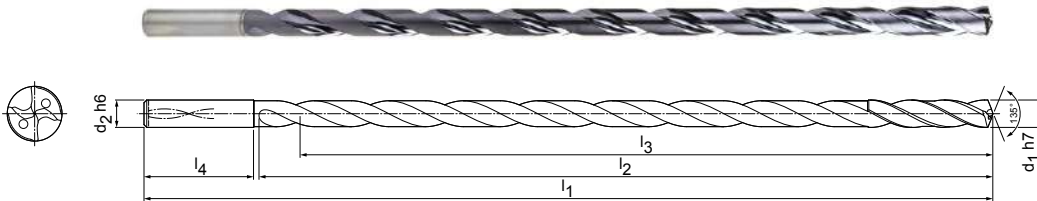

**Lagerhaltige Vorzugsbaureihe in Schaffform HA**

Baumaße						L/d-Verhältnis	Schaffform HA	
d <sub>1</sub> h7	d <sub>2</sub> h6	l <sub>1</sub>	l <sub>2</sub>	l <sub>3</sub>	l <sub>4</sub>		Spezifikation	Bestell-Nr.
3,00	4	125	91	87	32	29	M2125-0300AE	30213735
3,50	4	140	106	101	32	29	M2125-0350AE	30213736
4,00	4	140	106	100	32	25	M2125-0400AE	30213737
5,00	5	170	134	127	34	25	M2125-0500AE	30213739
5,50	6	185	147	139	36	25	M2125-0550AE	30213740
6,00	6	200	160	151	36	25	M2125-0600AE	30213741
7,00	7	225	185	175	38	25	M2125-0700AE	30213743
8,00	8	255	213	201	40	25	M2125-0800AE	30213745
9,00	9	280	238	225	40	25	M2125-0900AE	30213747
10,00	10	310	268	253	40	25	M2125-1000AE	30213748
11,00	11	340	293	277	45	25	M2125-1100AE	30213749
12,00	12	365	318	300	45	25	M2125-1200AE	30213750
14,00	14	425	373	352	50	25	M2125-1400AE	30213752

**Empfehlung für Pilotbohrer:**

Bitte verwenden Sie als Pilotbohrer den MEGA-Drill-Steel-Plus (M2103P - 3xD) mit dem gleichen Nenndurchmesser.

Spitzenwinkel und Durchmesser toleranzen sind für eine optimale Funktionalität sowie auf das Zusammenspiel von Pilotbohrer und Tiefbohrer abgestimmt.

**Anwendungstechnische Hinweise zum Tiefbohren finden Sie im Kapitel Technischer Anhang.**

Maßangaben in mm.  
Schnittwertempfehlung siehe Kapitelende.  
Sonderausführungen und andere Beschichtungen auf Anfrage.

# MEGA-Deep-Drill

Vollhartmetall-Tiefbohrer  
M2130 (30xD), innere Kühlmittelzufuhr

**Ausführung:**

Bohrerdurchmesser: 3,00 - 12,00 mm  
Bohrungstoleranz:  $\geq$  IT 9  
Beschichtung: MxF  
Schneidenanzahl: 2  
Anzahl Führungsfasen: 4  
Spitzenwinkel: 135°  
Spiralwinkel: 30°

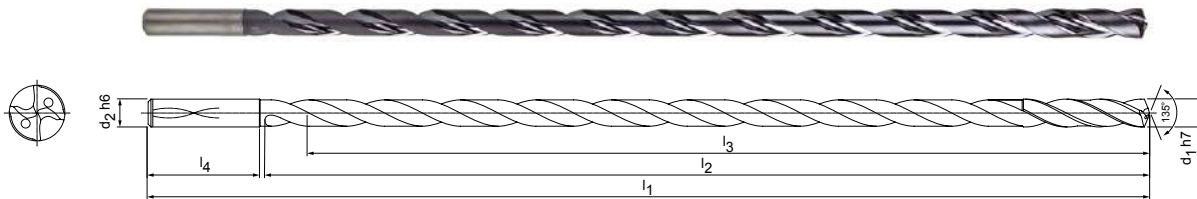
**Lagerhaltige Vorzugsbaureihe in Schaffform HA**

Baumaße						L/d-Verhältnis	Schaffform HA	
d <sub>1</sub> h7	d <sub>2</sub> h6	l <sub>1</sub>	l <sub>2</sub>	l <sub>3</sub>	l <sub>4</sub>		Spezifikation	Bestell-Nr.
3,00	4	145	110	106	32	35	M2130-0300AE	30213753
4,00	4	160	126	120	32	30	M2130-0400AE	30213755
4,50	5	180	144	137	34	31	M2130-0450AE	30213756
5,00	5	195	159	152	34	30	M2130-0500AE	30213757
5,50	6	210	172	164	36	30	M2130-0550AE	30213758
6,00	6	230	192	183	36	31	M2130-0600AE	30213759
7,00	7	260	220	210	38	30	M2130-0700AE	30213761
8,00	8	295	253	241	40	30	M2130-0800AE	30213763
9,00	9	325	283	270	40	30	M2130-0900AE	30213765
10,00	10	360	318	303	40	30	M2130-1000AE	30213766
11,00	11	400	353	337	45	31	M2130-1100AE	30213767
12,00	12	430	383	365	45	30	M2130-1200AE	30213768

**Empfehlung für Pilotbohrer:**

Bitte verwenden Sie als Pilotbohrer den MEGA-Drill-Steel-Plus (M2103P - 3xD) mit dem gleichen Nenndurchmesser.

Spitzenwinkel und Durchmesser-toleranzen sind für eine optimale Funktionalität sowie auf das Zusammenspiel von Pilotbohrer und Tiefbohrer abgestimmt.

**Anwendungstechnische Hinweise zum Tiefbohren finden Sie im Kapitel Technischer Anhang.**

Maßangaben in mm.

Schnittwertempfehlung siehe Kapitelende.

Sonderausführungen und andere Beschichtungen auf Anfrage.

# MEGA-Deep-Drill

Vollhartmetall-Tiefbohrer  
M2140 (40xD), innere Kühlmittelzufuhr

**Ausführung:**  
Bohrerdurchmesser: 4,00 - 6,00 mm  
Bohrungstoleranz:  $\geq IT 9$   
Beschichtung: MxF  
Schneidenanzahl: 2  
Anzahl Führungsfasen: 4  
Spitzenwinkel: 130°  
Spiralwinkel: 30°

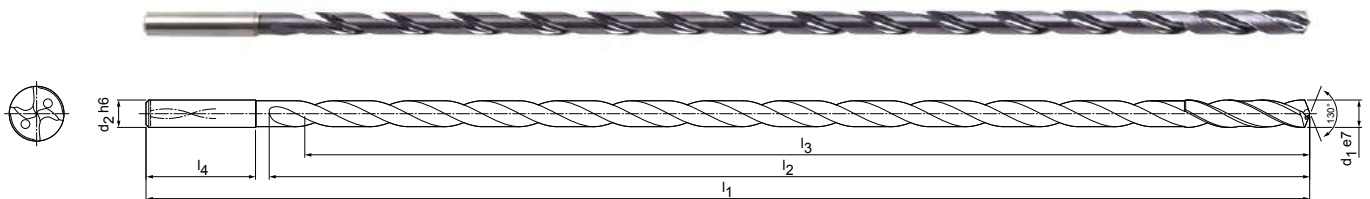

## Lagerhaltige Vorzugsbaureihe in Schaffform HA

Baumaße						L/d-Verhältnis	Schaffform HA	
d <sub>1</sub> e7	d <sub>2</sub> h6	l <sub>1</sub>	l <sub>2</sub>	l <sub>3</sub>	l <sub>4</sub>		Spezifikation	Bestell-Nr.
4,00	4	205	170	164	32	43	M2140-0400AE	30549900
5,00	5	245	208	201	34	42	M2140-0500AE	30549902
6,00	6	290	250	241	36	42	M2140-0600AE	30549904

## Empfehlung für Pilot- bzw. Vorbohrer:

Bitte verwenden Sie als Pilotbohrer den MEGA-Drill-Steel-Plus (M2103P - 3xD) mit dem gleichen Nenn Durchmesser. Anschließend mit MEGA-Deep-Drill (M2120 - 20xD) und ebenfalls gleichem Nenn Durchmesser vorbohren. Spitzenwinkel und Durchmesser toleranz sind für eine optimale Funktionalität sowie auf das Zusammenspiel von Pilotbohrer und Tiefbohrer abgestimmt.

Anwendungstechnische Hinweise zum Tiefbohren finden Sie im Kapitel Technischer Anhang.

Maßangaben in mm.  
Schnittwertempfehlung siehe Kapitelende.  
Sonderausführungen und andere Beschichtungen auf Anfrage.

# MEGA-Deep-Drill-Alu

Vollhartmetall-Tiefbohrer  
M2815 (15xD), innere Kühlmittelzufuhr

## Ausführung:

Bohrerdurchmesser: 3,00 - 12,00 mm  
Bohrungstoleranz:  $\geq$  IT 9  
Beschichtung: Unbeschichtet  
Schneidenanzahl: 2  
Anzahl Führungsfasen: 4  
Spitzenwinkel: 135°  
Spiralwinkel: 30°

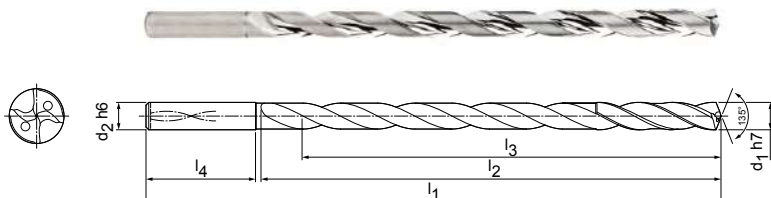

## Lagerhaltige Vorzugsbaureihe in Schaffform HA

Baumaße						L/d-Verhältnis	Schaffform HA	
d <sub>1</sub> h7	d <sub>2</sub> h6	l <sub>1</sub>	l <sub>2</sub>	l <sub>3</sub>	l <sub>4</sub>		Spezifikation	Bestell-Nr.
3,00	4	90	56	52	32	17	M2815-0300AU	30286747
3,50	4	100	66	61	32	17	M2815-0350AU	30286748
4,00	4	100	66	60	32	15	M2815-0400AU	30286749
5,00	5	120	84	77	34	15	M2815-0500AU	30286751
6,00	6	140	102	93	36	16	M2815-0600AU	30286753
7,00	7	155	115	105	38	15	M2815-0700AU	30286754
8,00	8	175	133	121	40	15	M2815-0800AU	30286755
10,00	10	210	168	153	40	15	M2815-1000AU	30286757
12,00	12	250	203	185	45	15	M2815-1200AU	30286759

## Empfehlung für Pilotbohrer:

Bitte verwenden Sie als Pilotbohrer den MEGA-Drill-Alu (M2803 / M2805 - 3xD/5xD) mit dem gleichen Nenndurchmesser.

Spitzenwinkel und Durchmesser toleranzen sind für eine optimale Funktionalität sowie auf das Zusammenspiel von Pilotbohrer und Tiefbohrer abgestimmt.

**Anwendungstechnische Hinweise zum Tiefbohren finden Sie im Kapitel Technischer Anhang.**

Maßangaben in mm.

Schnittwertempfehlung siehe Kapitelende.

Sonderausführungen und andere Beschichtungen auf Anfrage.

# MEGA-Deep-Drill-Alu

Vollhartmetall-Tiefbohrer  
M2820 (20xD), innere Kühlmittelzufuhr

**Ausführung:**

Bohrerdurchmesser: 3,00 - 12,00 mm  
Bohrungstoleranz:  $\geq$  IT 9  
Beschichtung: Unbeschichtet  
Schneidenanzahl: 2  
Anzahl Führungsfasen: 4  
Spitzenwinkel: 135°  
Spiralwinkel: 30°

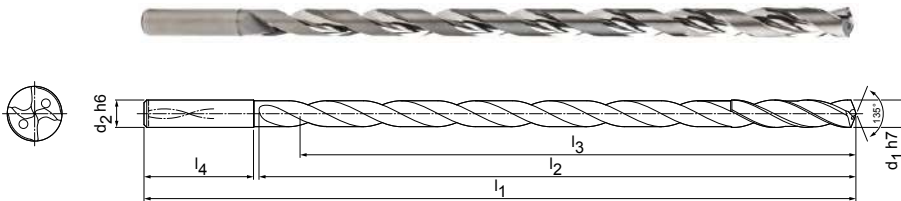

**Lagerhaltige Vorzugsbaureihe in Schaffform HA**

Baumaße						L/d-Verhältnis	Schaffform HA	
d <sub>1</sub> h7	d <sub>2</sub> h6	l <sub>1</sub>	l <sub>2</sub>	l <sub>3</sub>	l <sub>4</sub>		Spezifikation	Bestell-Nr.
3,00	4	110	74	70	32	23	M2820-0300AU	30286764
4,00	4	120	86	80	32	20	M2820-0400AU	30286766
5,00	5	145	109	102	34	20	M2820-0500AU	30286768
5,50	6	160	120	112	36	20	M2820-0550AU	30286769
6,00	6	170	130	121	36	20	M2820-0600AU	30286770
7,00	7	190	150	140	38	20	M2820-0700AU	30286771
8,00	8	215	173	161	40	20	M2820-0800AU	30286772
10,00	10	260	218	203	40	20	M2820-1000AU	30286774
12,00	12	305	258	240	45	20	M2820-1200AU	30286776

**Empfehlung für Pilotbohrer:**

Bitte verwenden Sie als Pilotbohrer den MEGA-Drill-Alu (M2803 / M2805 - 3xD/5xD) mit dem gleichen Nenndurchmesser.

Spitzenwinkel und Durchmesser-toleranzen sind für eine optimale Funktionalität sowie auf das Zusammenspiel von Pilotbohrer und Tiefbohrer abgestimmt.

**Anwendungstechnische Hinweise zum Tiefbohren finden Sie im Kapitel Technischer Anhang.**

Maßangaben in mm.  
Schnittwertempfehlung siehe Kapitelende.  
Sonderausführungen und andere Beschichtungen auf Anfrage.

# MEGA-Deep-Drill-Alu

Vollhartmetall-Tiefbohrer  
M2825 (25xD), innere Kühlmittelzufuhr

## Ausführung:

Bohrerdurchmesser:	3,00 - 10,00 mm
Bohrungstoleranz:	≥ IT 9
Beschichtung:	Unbeschichtet
Schneidenanzahl:	2
Anzahl Führungsfasen:	4
Spitzenwinkel:	135°
Spiralwinkel:	30°

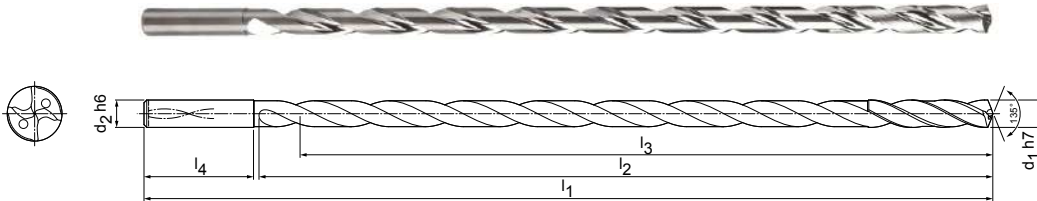

## Lagerhaltige Vorzugsbaureihe in Schaffform HA

Baumaße						L/d-Verhältnis	Schaffform HA	
d <sub>1</sub> h7	d <sub>2</sub> h6	l <sub>1</sub>	l <sub>2</sub>	l <sub>3</sub>	l <sub>4</sub>		Spezifikation	Bestell-Nr.
3,00	4	125	91	87	32	29	M2825-0300AU	30286781
4,00	4	140	106	100	32	25	M2825-0400AU	30286783
5,00	5	170	134	127	34	25	M2825-0500AU	30286785
6,00	6	200	160	151	36	25	M2825-0600AU	30286787
7,00	7	225	185	175	38	25	M2825-0700AU	30286788
8,00	8	255	213	201	40	25	M2825-0800AU	30286789
10,00	10	310	268	253	40	25	M2825-1000AU	30286791

## Empfehlung für Pilotbohrer:

Bitte verwenden Sie als Pilotbohrer den MEGA-Drill-Alu (M2803 / M2805 - 3xD/5xD) mit dem gleichen Nenndurchmesser.

Spitzenwinkel und Durchmesser toleranzen sind für eine optimale Funktionalität sowie auf das Zusammenspiel von Pilotbohrer und Tiefbohrer abgestimmt.

**Anwendungstechnische Hinweise zum Tiefbohren finden Sie im Kapitel Technischer Anhang.**

Maßangaben in mm.

Schnittwertempfehlung siehe Kapitelende.

Sonderausführungen und andere Beschichtungen auf Anfrage.



# MEGA-Deep-Drill-Alu

Vollhartmetall-Tiefbohrer  
M2830 (30xD), innere Kühlmittelzufuhr

**Ausführung:**  
Bohrerdurchmesser: 4,00 - 6,00 mm  
Bohrungstoleranz:  $\geq IT 9$   
Beschichtung: Unbeschichtet  
Schneidenanzahl: 2  
Anzahl Führungsfasen: 4  
Spitzenwinkel:  $135^\circ$   
Spiralwinkel:  $30^\circ$

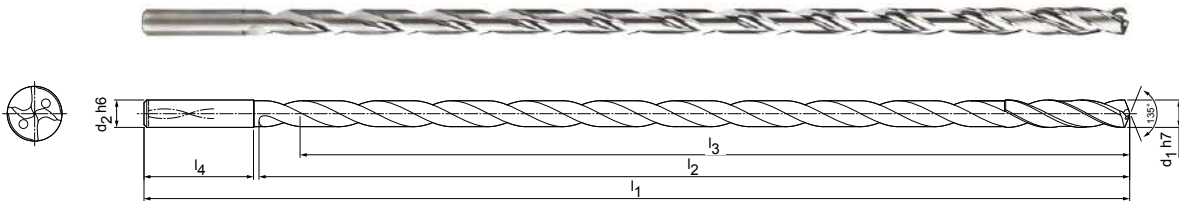

Performance LINE

IT9 30xD HA DIN 6535

P 1 2 3 4 5 6 M 1 2 3 K 1 2 3 N 1 2 3 4 S 1 2 3 4 5 H 1 2 3

### Lagerhaltige Vorzugsbaureihe in Schaffform HA

Baumaße						L/d-Verhältnis	Schaffform HA	
d <sub>1</sub> h7	d <sub>2</sub> h6	l <sub>1</sub>	l <sub>2</sub>	l <sub>3</sub>	l <sub>4</sub>		Spezifikation	Bestell-Nr.
4,00	4	160	126	120	32	30	M2830-0400AU	30286798
4,50	5	180	144	137	34	31	M2830-0450AU	30286799
5,00	5	195	159	152	34	30	M2830-0500AU	30286800
6,00	6	230	192	183	36	31	M2830-0600AU	30286802

### Empfehlung für Pilotbohrer:

Bitte verwenden Sie als Pilotbohrer den MEGA-Drill-Alu (M2803 / M2805 - 3xD/5xD) mit dem gleichen Nenndurchmesser.

Spitzenwinkel und Durchmesser toleranzen sind für eine optimale Funktionalität sowie auf das Zusammenspiel von Pilotbohrer und Tiefbohrer abgestimmt.

Anwendungstechnische Hinweise zum Tiefbohren finden Sie im Kapitel Technischer Anhang.

Maßangaben in mm.  
Schnittwertempfehlung siehe Kapitelende.  
Sonderausführungen und andere Beschichtungen auf Anfrage.

# MEGA-Deep-Drill-Alu

Vollhartmetall-Tiefbohrer  
M2840 (40xD), innere Kühlmittelzufuhr

**Ausführung:**

Bohrerdurchmesser: 6,00 - 7,00 mm  
Bohrungstoleranz:  $\geq IT 9$   
Beschichtung: Unbeschichtet  
Schneidenanzahl: 2  
Anzahl Führungsfasen: 4  
Spitzenwinkel:  $130^\circ$   
Spiralwinkel:  $30^\circ$

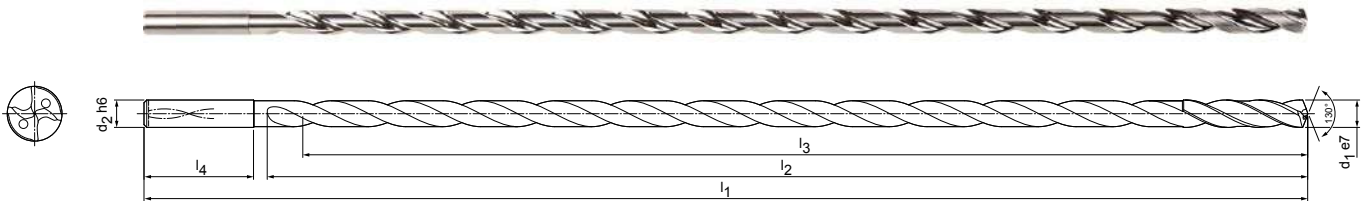
**Lagerhaltige Vorzugsbaureihe in Schaffform HA**

Baumaße						L/d-Verhältnis	Schaffform HA	
d <sub>1</sub> h7	d <sub>2</sub> h6	l <sub>1</sub>	l <sub>2</sub>	l <sub>3</sub>	l <sub>4</sub>		Spezifikation	Bestell-Nr.
6,00	6	290	250	241	36	42	M2840-0600AU	30549914
7,00	7	330	290	280	38	41	M2840-0700AU	30549915

**Empfehlung für Pilotbohrer:**

Bitte verwenden Sie als Pilotbohrer den MEGA-Drill-Alu (M2803 / M2805 - 3xD/5xD) mit dem gleichen Nenndurchmesser.

Spitzenwinkel und Durchmesser toleranzen sind für eine optimale Funktionalität sowie auf das Zusammenspiel von Pilotbohrer und Tiefbohrer abgestimmt.

**Anwendungstechnische Hinweise zum Tiefbohren finden Sie im Kapitel Technischer Anhang.**

Maßangaben in mm.

Schnittwertempfehlung siehe Kapitelende.

Sonderausführungen und andere Beschichtungen auf Anfrage.



# Schnittwertempfehlung für Tiefbohrer

Vorschub und Schnittgeschwindigkeit

## MEGA-Pilot-Drill | M2413

MZG*	Werkstoff	Festigkeit/Härte [N/mm <sup>2</sup> ] [HRC]
P	P1.1 Bau-, Automaten-, Einsatz- und Vergütungsstähle, unlegiert	< 700
	P1.2 Bau-, Automaten-, Einsatz- und Vergütungsstähle, unlegiert	< 1.200
	P2.1 Nitrier-, Einsatz- und Vergütungsstähle, legiert	< 900
	P2.2 Nitrier-, Einsatz- und Vergütungsstähle, legiert	< 1.400
	P3.1 Werkzeug-, Wälzlager-, Feder- und Schnellarbeitsstähle**	< 800
	P3.2 Werkzeug-, Wälzlager-, Feder- und Schnellarbeitsstähle**	< 1.000
	P3.3 Werkzeug-, Wälzlager-, Feder- und Schnellarbeitsstähle**	< 1.500
	P5.1 Stahlguss	
M	M1.1 Rostfreie Stähle, austenitisch	< 700
	M1.2 Rostfreie Stähle, ferritisch/austenitisch (Duplex)	< 1.000
K	K1.1 Gusseisen mit Lamellengraphit (Grauguss), GJL	< 300
	K2.1 Gusseisen mit Kugelgraphit, GJS	< 500
	K2.2 Gusseisen mit Kugelgraphit, GJS	≤ 800
	K2.3 Gusseisen mit Kugelgraphit, GJS	> 800
	K3.1 Gusseisen mit Vermiculargraphit, GJV; Temperguss, GJM	< 500
	K3.2 Gusseisen mit Vermiculargraphit, GJV; Temperguss, GJM	> 500

\* MILLER Zerspanungsgruppen

\*\* Wenn die Legierungsbestandteile Cr, Mo, Ni, V, W in Summe > 8 %, dann die nächst höhere MILLER Zerspanungsgruppe wählen.

	Schnittgeschwindigkeit $v_c$ [m/min]				Vorschub $f$ [mm] bei Bohrerdurchmesser					
	Innenkühlung	Außenkühlung	MMS	Luft	1,00	1,20	1,60	1,90	2,40	3,00
	<b>80</b>	<b>70</b>	<b>70</b>		0,05	0,06	0,06	0,07	0,08	0,09
	<b>70</b>	<b>60</b>	<b>60</b>		0,07	0,07	0,08	0,09	0,10	0,11
	<b>80</b>	<b>70</b>	<b>70</b>		0,06	0,07	0,08	0,08	0,10	0,11
	<b>55</b>	<b>50</b>	<b>50</b>		0,06	0,06	0,07	0,07	0,08	0,09
	<b>60</b>	<b>50</b>	<b>50</b>		0,06	0,06	0,07	0,07	0,08	0,10
	<b>50</b>	<b>45</b>	<b>45</b>		0,05	0,05	0,06	0,07	0,07	0,08
	<b>50</b>	<b>35</b>	<b>40</b>		0,05	0,05	0,05	0,06	0,06	0,07
	<b>80</b>	<b>70</b>	<b>70</b>		0,06	0,07	0,08	0,08	0,10	0,11
	<b>45</b>	<b>30</b>	<b>30</b>		0,04	0,04	0,05	0,05	0,06	0,06
	<b>95</b>	<b>70</b>	<b>70</b>	<b>70</b>	0,06	0,07	0,08	0,09	0,10	0,12
	<b>130</b>	<b>80</b>	<b>95</b>	<b>95</b>	0,07	0,07	0,08	0,09	0,11	0,13
	<b>80</b>	<b>60</b>	<b>60</b>		0,06	0,07	0,08	0,09	0,10	0,11
	<b>70</b>	<b>65</b>	<b>65</b>		0,07	0,08	0,08	0,09	0,11	0,12
	<b>65</b>	<b>55</b>	<b>55</b>		0,06	0,07	0,08	0,08	0,09	0,11

Die angegebenen Schnittwerte sind Richtwerte.

Die für den jeweiligen Bearbeitungsfall optimalen Daten sollten im Versuch oder während der Bearbeitung ermittelt werden.

# Schnittwertempfehlung für Tiefbohrer

Vorschub und Schnittgeschwindigkeit

## MEGA-Deep-Drill I M2120, M2130, M2115, M2120, M2125, M2130, M2140

MZG*		Werkstoff	Festigkeit/Härte [N/mm <sup>2</sup> ] [HRC]
P	P1	P1.1 Bau-, Automaten-, Einsatz- und Vergütungsstähle, unlegiert	< 700
		P1.2 Bau-, Automaten-, Einsatz- und Vergütungsstähle, unlegiert	< 1.200
	P2	P2.1 Nitrier-, Einsatz- und Vergütungsstähle, legiert	< 900
		P2.2 Nitrier-, Einsatz- und Vergütungsstähle, legiert	< 1.400
	P3	P3.1 Werkzeug-, Wälzlager-, Feder- und Schnellarbeitsstähle**	< 800
		P3.2 Werkzeug-, Wälzlager-, Feder- und Schnellarbeitsstähle**	< 1.000
		P3.3 Werkzeug-, Wälzlager-, Feder- und Schnellarbeitsstähle**	< 1.500
	P5	P5.1 Stahlguss	
	K	K1	K1.1 Gusseisen mit Lamellengraphit (Grauguss), GJL
K2.1 Gusseisen mit Kugelgraphit, GJS			< 500
K2		K2.2 Gusseisen mit Kugelgraphit, GJS	≤ 800
		K2.3 Gusseisen mit Kugelgraphit, GJS	> 800
K3		K3.1 Gusseisen mit Vermiculargraphit, GJV; Temperguss, GJM	< 500
		K3.2 Gusseisen mit Vermiculargraphit, GJV; Temperguss, GJM	> 500

## MEGA-Deep-Drill-Alu I M2815, M2820, M2825, M2830, M2840

MZG*		Werkstoff	Festigkeit/Härte [N/mm <sup>2</sup> ] [HRC]
N	N1	N1.1 Aluminium, unlegiert und legiert < 3 % Si	
		N1.2 Aluminium, legiert ≤ 7 % Si	
		N1.3 Aluminium, legiert > 7-12 % Si	
		N1.4 Aluminium, legiert > 12 % Si	
	N2	N2.1 Kupfer, unlegiert und niedriglegiert	< 300
		N2.2 Kupfer, legiert	> 300
		N2.3 Messing, Bronze, Rotguss	< 1.200

\* MILLER Zerspanungsgruppen

\*\* Wenn die Legierungsbestandteile Cr, Mo, Ni, V, W in Summe > 8 %, dann die nächst höhere MILLER Zerspanungsgruppe wählen.

	Schnittgeschwindigkeit $v_c$ [m/min]				Vorschub $f$ [mm] bei Bohrerdurchmesser					
	Innenkühlung	Außenkühlung	MMS	Luft	1,00	2,00	4,00	6,00	9,00	16,00
	<b>90</b>	<b>80</b>	<b>80</b>		0,04	0,06	0,09	0,13	0,19	0,27
	<b>80</b>	<b>70</b>	<b>70</b>		0,06	0,08	0,11	0,16	0,24	0,34
	<b>90</b>	<b>75</b>	<b>75</b>		0,05	0,07	0,10	0,16	0,23	0,32
	<b>65</b>	<b>55</b>	<b>55</b>		0,05	0,07	0,09	0,13	0,18	0,25
	<b>70</b>	<b>60</b>	<b>60</b>		0,05	0,06	0,09	0,14	0,21	0,29
	<b>55</b>	<b>50</b>	<b>50</b>		0,04	0,06	0,08	0,12	0,17	0,23
	<b>55</b>	<b>40</b>	<b>45</b>		0,04	0,05	0,07	0,09	0,13	0,18
	<b>90</b>	<b>75</b>	<b>75</b>		0,05	0,07	0,10	0,16	0,23	0,32
	<b>110</b>	<b>75</b>	<b>75</b>	<b>75</b>	0,14	0,18	0,25	0,32	0,41	0,53
	<b>145</b>	<b>90</b>	<b>110</b>	<b>110</b>	0,14	0,18	0,24	0,30	0,38	0,49
	<b>90</b>	<b>70</b>	<b>70</b>		0,13	0,16	0,21	0,26	0,33	0,42
	<b>55</b>	<b>35</b>	<b>45</b>		0,10	0,12	0,14	0,18	0,22	0,28
	<b>80</b>	<b>70</b>	<b>70</b>		0,14	0,18	0,22	0,28	0,36	0,46
	<b>70</b>	<b>65</b>	<b>65</b>		0,12	0,15	0,18	0,23	0,29	0,36

	Schnittgeschwindigkeit $v_c$ [m/min]				Vorschub $f$ [mm] bei Bohrerdurchmesser					
	Innenkühlung	Außenkühlung	MMS	Luft	3,00	4,00	5,50	7,50	10,50	16,00
	<b>300</b>	<b>200</b>	<b>250</b>		0,11	0,13	0,16	0,20	0,25	0,32
	<b>250</b>	<b>180</b>	<b>200</b>		0,13	0,16	0,21	0,26	0,33	0,42
	<b>220</b>	<b>150</b>	<b>180</b>		0,13	0,16	0,21	0,26	0,33	0,42
	<b>180</b>	<b>120</b>	<b>150</b>		0,13	0,16	0,21	0,26	0,33	0,42
	<b>140</b>	<b>100</b>			0,09	0,11	0,14	0,17	0,21	0,27
	<b>120</b>	<b>90</b>			0,11	0,14	0,17	0,22	0,28	0,35
	<b>200</b>	<b>160</b>	<b>160</b>	<b>120</b>	0,14	0,18	0,25	0,32	0,41	0,53

Die angegebenen Schnittwerte sind Richtwerte.

Die für den jeweiligen Bearbeitungsfall optimalen Daten sollten im Versuch oder während der Bearbeitung ermittelt werden.





# BOHRREIBEN

## Bohrreibahlen

---

Technologie .....	298
Tritan-Drill-Reamer .....	300

## Technischer Anhang

---

Schnittwertempfehlung .....	306
-----------------------------	-----

# TRITAN-DRILL-REAMER

## Die genaueste Lösung zum Bohren und Reiben in einem Arbeitsgang

Um möglichst wirtschaftlich zu fertigen, ist es ein bewährtes Mittel, mehrere Bearbeitungsschritte in einem Werkzeug zusammenzufassen. So können beispielsweise Bohrungen mit dem Tritan-Drill-Reamer von MILLER gleichzeitig gebohrt und gerieben werden.

Um Passungsbohrungen noch genauer mit nur einem Werkzeug herstellen zu können, hat MILLER den Tritan-Drill-Reamer entwickelt.

Mit sechs Führungsfasen für exzellente Führungseigenschaften, feinstgeschliffenen Spannuten mit abgestimmter Nutform für gute Spanabfuhr und einer selbstzentrierenden Querschneide überzeugt der neue Tritan-Drill-Reamer auf ganzer Linie.

Die selbstzentrierende Querschneide sorgt für gute Positionsgenauigkeit und ein verbessertes Anbohrverhalten. Drei Schneiden garantieren eine optimale Rundheit der Passungsbohrung und höchste Leistungsfähigkeit. Die Führungsfasen erzeugen beste Oberflächen.

### MERKMALE

- Kombination aus Bohren und Reiben
- Längenausführung 3xD und 5xD
- Drei Schneiden und sechs Führungsfasen
- Mit Innenkühlung
- Toleranzausführungen  $\pm 0,003$  mm und H7

### VORTEILE

- Reduzierte Haupt- und Nebenzeiten
- Beste Performance und höchste Genauigkeiten
- Hohe Positionsgenauigkeit
- Optimale Rundheit

## Werkzeugfeatures im Detail

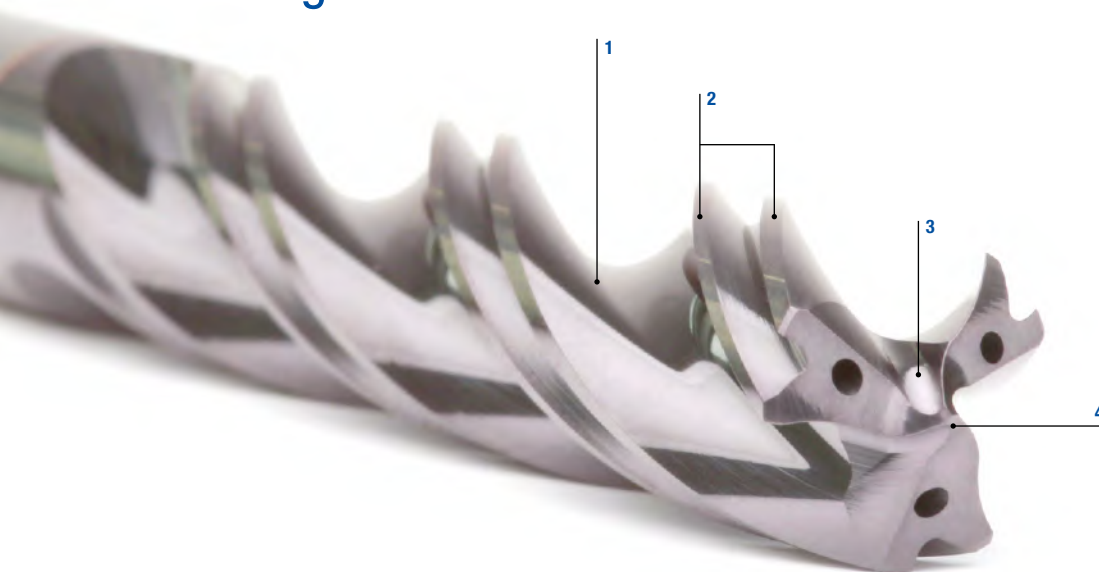

- 1 Feinstgeschliffenes Nutprofil
- 2 Sechs Führungsfasen
- 3 Innovative Ausspitzung
- 4 Selbstzentrierende Querschneide



### Sechs Führungsfasen

- Für exzellente Führungseigenschaften
- Zur Herstellung von Passungsbohrungen mit höchster Wirtschaftlichkeit und Genauigkeit mit nur einem Werkzeug



### Innovative Zentrierspitze

- Selbstzentrierende Querschneide für sehr gute Positionsgenauigkeit und verbessertes Anbohrverhalten

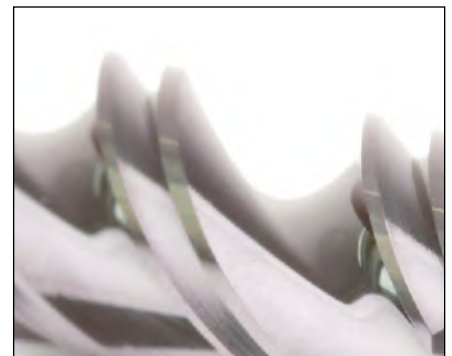

### Feinstgeschliffenes Nutprofil

- Feinstgeschliffene Spannuten mit abgestimmter Nutform für sehr gute Spanabfuhr



## Vergleich Tritan-Drill-Reamer und zweischneidige Lösung

Durchmesserabweichung vom gemessenen Werkzeugdurchmesser (42CrMoS4)

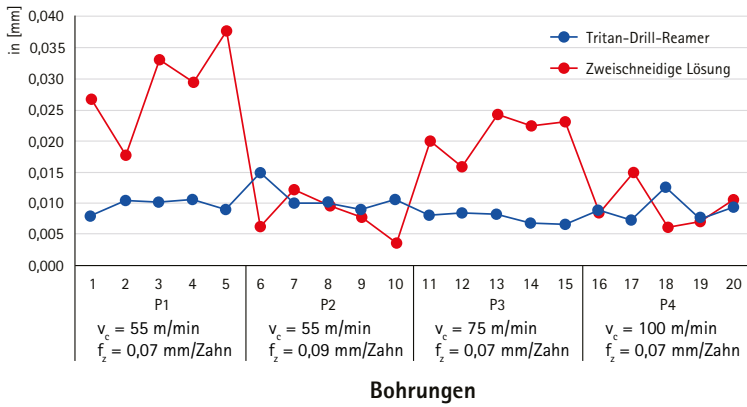

Rundheit über 600 Bohrungen

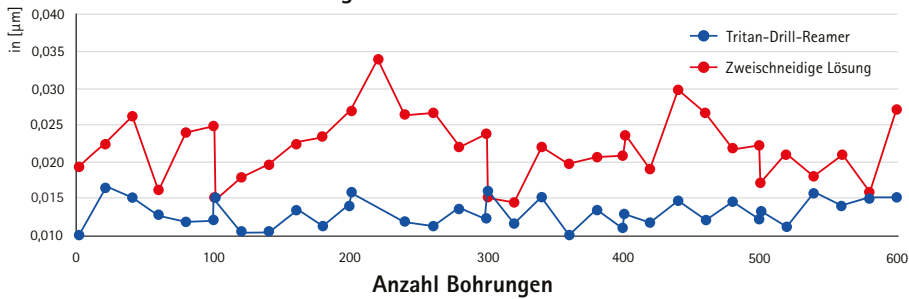

# Tritan-Drill-Reamer

Vollhartmetall-Bohrreibahle  
M9963 (3xD), innere Kühlmittelzufuhr

**Ausführung:**  
Bohrerdurchmesser: 3,80 - 20,05 mm  
Bohrungstoleranz:  $\geq$  IT 7  
Beschichtung: MxP  
Schneidenanzahl: 3  
Anzahl Führungsfasen: 6  
Spitzenwinkel:  $140^\circ$   
Spiralwinkel:  $30^\circ$

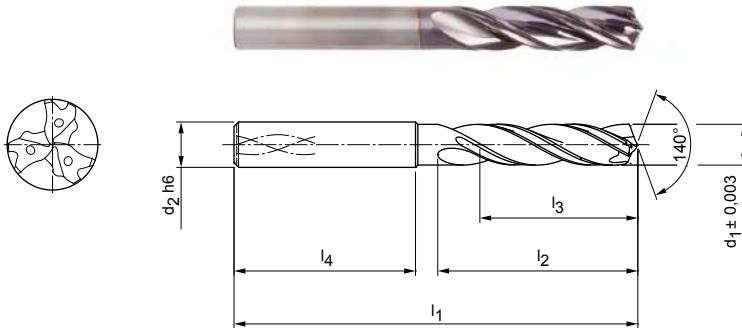

## Lagerhaltige Vorzugsbaureihe in Schaftform HA

Baumaße						Schaftform HA	
$d_1 \pm 0,003$	$d_2 h6$	$l_1$	$l_2$	$l_3$	$l_4$	Spezifikation	Bestell-Nr.
3,99	6	66	24	17	36	M9963-3.990+3-3AR	31196425
4,00	6	66	24	17	36	M9963-4.000+3-3AR	31196426
4,01	6	66	24	17	36	M9963-4.010+3-3AR	31196427
4,99	6	66	28	20	36	M9963-4.990+3-3AR	31196431
5,00	6	66	28	20	36	M9963-5.000+3-3AR	31196432
5,01	6	66	28	20	36	M9963-5.010+3-3AR	31196433
5,02	6	66	28	20	36	M9963-5.020+3-3AR	31196434
5,99	6	66	28	20	36	M9963-5.990+3-3AR	31196437
6,00	6	66	28	20	36	M9963-6.000+3-3AR	31196438
6,01	6	66	28	20	36	M9963-6.010+3-3AR	31196439
7,99	8	79	41	29	36	M9963-7.990+3-3AR	31196443
8,00	8	79	41	29	36	M9963-8.000+3-3AR	31196444
8,01	8	79	41	29	36	M9963-8.010+3-3AR	31196445
9,99	10	89	47	35	40	M9963-9.990+3-3AR	31196449
10,00	10	89	47	35	40	M9963-10.000+3-3AR	31196450
10,01	10	89	47	35	40	M9963-10.010+3-3AR	31196451
10,02	10	89	47	35	40	M9963-10.020+3-3AR	31196452
11,99	12	102	55	40	45	M9963-11.990+3-3AR	31196455
12,00	12	102	55	40	45	M9963-12.000+3-3AR	31196456
12,01	12	102	55	40	45	M9963-12.010+3-3AR	31196457
13,99	14	107	60	43	45	M9963-13.990+3-3AR	31196461
14,00	14	107	60	43	45	M9963-14.000+3-3AR	31196462
14,01	14	107	60	43	45	M9963-14.010+3-3AR	31196463
15,99	16	115	65	45	48	M9963-15.990+3-3AR	31196467
16,00	16	115	65	45	48	M9963-16.000+3-3AR	31196468
16,01	16	115	65	45	48	M9963-16.010+3-3AR	31196469

## Tritan-Drill-Reamer | Vollhartmetall-Bohrreibahle M9963 (3xD), innere Kühlmittelzufuhr

## Konfigurierbare Merkmale



**Durchmesser:**  
Durchmesser in Abstufungen  
von 0,001 mm frei wählbar

**Spezifikation:**

M9963-[Durchmesser]+3-3AR

**Beispiel:**

M9963-4.001+3-3AR

Werkzeugdurchmesser  $d_1 = 4,001$  mm

## Abmessungen konfigurierbare Baureihe

$d_1$ min.	$d_1$ max.	$d_2$ h6	$l_1$	$l_2$	$l_3$	$l_4$
3,800	4,700	6	66	24	17	36
4,701	6,050	6	66	28	20	36
6,051	8,050	8	79	41	29	36
8,051	10,050	10	89	47	35	40
10,051	12,050	12	102	55	40	45
12,970	14,050	14	107	60	43	45
14,970	16,050	16	115	65	45	48
16,800	18,050	18	123	73	51	48
18,700	20,050	20	131	79	55	50

Maßangaben in mm.

Für Passungsbohrungen der Toleranzklassen bis max. IT7, bei ausreichender Maschinenstabilität und Kühlung.

Die Hilfe zur Berechnung des optimalen Nenndurchmessers für unterschiedliche Passungsbohrungen entnehmen Sie bitte dem Informationsfeld am Kapitelende.

Schnittwertempfehlung siehe Kapitelende.

Sonderausführungen und andere Beschichtungen auf Anfrage.

# Tritan-Drill-Reamer

Vollhartmetall-Bohrreibahle  
M9963 (3xD), innere Kühlmittelzufuhr

**Ausführung:**  
Bohrerdurchmesser: 4,00 - 16,00 mm  
Bohrungstoleranz:  $\geq$  IT 7  
Beschichtung: MxP  
Schneidenanzahl: 3  
Anzahl Führungsfasen: 6  
Spitzenwinkel: 140°  
Spiralwinkel: 30°

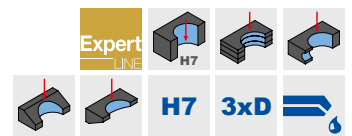
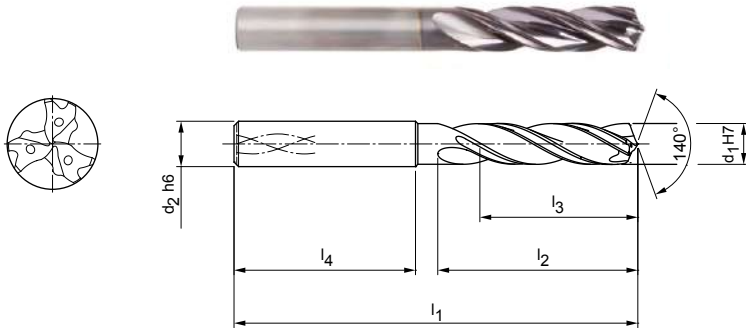

## Lagerhaltige Vorzugsbaureihe in Schaftform HA

Baumaße						Schaftform HA	
d <sub>1</sub> H7	d <sub>2</sub> h6	l <sub>1</sub>	l <sub>2</sub>	l <sub>3</sub>	l <sub>4</sub>	Spezifikation	Bestell-Nr.
4,00	6	66	24	17	36	M9963-4.000H7AR	31196298
5,00	6	66	28	20	36	M9963-5.000H7AR	31196322
6,00	6	66	28	20	36	M9963-6.000H7AR	31196323
8,00	8	79	41	29	36	M9963-8.000H7AR	31196324
10,00	10	89	47	35	40	M9963-10.000H7AR	31196325
12,00	12	102	55	40	45	M9963-12.000H7AR	31196326
14,00	14	107	60	43	45	M9963-14.000H7AR	31196327
16,00	16	115	65	45	48	M9963-16.000H7AR	31196328

Maßangaben in mm.  
Für Passungsbohrungen der Toleranzklasse H7, bei ausreichender Maschinenstabilität und Kühlung.  
Schnittwertempfehlung siehe Kapitelende.  
Sonderausführungen und andere Beschichtungen auf Anfrage.

# Tritan-Drill-Reamer

Vollhartmetall-Bohrreibahle  
M9965 (5xD), innere Kühlmittelzufuhr

**Ausführung:**  
Bohrerdurchmesser: 3,80 - 20,05 mm  
Bohrungstoleranz:  $\geq$  IT 7  
Beschichtung: MxP  
Schneidenanzahl: 3  
Anzahl Führungsfasen: 6  
Spitzenwinkel: 140°  
Spiralwinkel: 30°

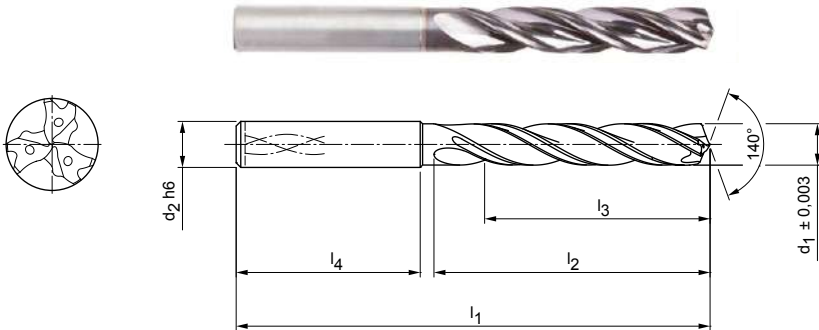

## Lagerhaltige Vorzugsbaureihe in Schaftform HA

Baumaße						Schaftform HA	
$d_1 \pm 0,003$	$d_2$ h6	$l_1$	$l_2$	$l_3$	$l_4$	Spezifikation	Bestell-Nr.
3,99	6	74	36	29	36	M9965-3.990+3-3AR	31196495
4,00	6	74	36	29	36	M9965-4.000+3-3AR	31196496
4,01	6	74	36	29	36	M9965-4.010+3-3AR	31196497
4,02	6	74	36	29	36	M9965-4.020+3-3AR	31196498
4,99	6	82	44	35	36	M9965-4.990+3-3AR	31196501
5,00	6	82	44	35	36	M9965-5.000+3-3AR	31196502
5,01	6	82	44	35	36	M9965-5.010+3-3AR	31196503
5,99	6	82	44	35	36	M9965-5.990+3-3AR	31196507
6,00	6	82	44	35	36	M9965-6.000+3-3AR	31196508
6,01	6	82	44	35	36	M9965-6.010+3-3AR	31196509
7,99	8	91	53	43	36	M9965-7.990+3-3AR	31196513
8,00	8	91	53	43	36	M9965-8.000+3-3AR	31196514
8,01	8	91	53	43	36	M9965-8.010+3-3AR	31196515
8,02	8	91	53	43	36	M9965-8.020+3-3AR	31196516
9,99	10	103	61	49	40	M9965-9.990+3-3AR	31196519
10,00	10	103	61	49	40	M9965-10.000+3-3AR	31196520
10,01	10	103	61	49	40	M9965-10.010+3-3AR	31196521
11,99	12	118	71	59	45	M9965-11.990+3-3AR	31196525
12,00	12	118	71	59	45	M9965-12.000+3-3AR	31196526
12,01	12	118	71	59	45	M9965-12.010+3-3AR	31196527
13,99	14	124	77	60	45	M9965-13.990+3-3AR	31196531
14,00	14	124	77	60	45	M9965-14.000+3-3AR	31196532
14,01	14	124	77	60	45	M9965-14.010+3-3AR	31196533
15,99	16	133	83	63	48	M9965-15.990+3-3AR	31196537
16,00	16	133	83	63	48	M9965-16.000+3-3AR	31196538
16,01	16	133	83	63	48	M9965-16.010+3-3AR	31196539

Fortsetzung auf nächster Seite.

## Tritan-Drill-Reamer | Vollhartmetall-Bohrreibahle M9965 (5xD), innere Kühlmittelzufuhr

## Konfigurierbare Merkmale



**Durchmesser:**  
Durchmesser in Abstufungen  
von 0,001 mm frei wählbar

**Spezifikation:**

M9965-[Durchmesser]+3-3AR

**Beispiel:**

M9965-4.001+3-3AR

Werkzeugdurchmesser  $d_1 = 4,001$  mm

## Abmessungen konfigurierbare Baureihe

$d_1$ min.	$d_1$ max.	$d_2$ h6	$l_1$	$l_2$	$l_3$	$l_4$
3,800	4,700	6	74	36	29	36
4,701	6,050	6	82	44	35	36
6,051	8,050	8	91	53	43	36
8,051	10,050	10	103	61	49	40
10,051	12,050	12	118	71	56	45
12,970	14,050	14	124	77	60	45
14,970	16,050	16	133	83	63	48
16,800	18,050	18	143	93	71	48
18,700	20,050	20	153	101	77	50

Maßangaben in mm.

Für Passungsbohrungen der Toleranzklassen bis max. IT7, bei ausreichender Maschinenstabilität und Kühlung.

Die Hilfe zur Berechnung des optimalen Nenndurchmessers für unterschiedliche Passungsbohrungen entnehmen Sie bitte dem Informationsfeld am Kapitelende.

Schnittwertempfehlung siehe Kapitelende.

Sonderausführungen und andere Beschichtungen auf Anfrage.



# Tritan-Drill-Reamer

Vollhartmetall-Bohrreibahle  
M9965 (5xD), innere Kühlmittelzufuhr

**Ausführung:**  
Bohrerdurchmesser: 4,00 - 20,00 mm  
Bohrungstoleranz:  $\geq$  IT 7  
Beschichtung: MxP  
Schneidenanzahl: 3  
Anzahl Führungsfasen: 6  
Spitzenwinkel: 140°  
Spiralwinkel: 30°

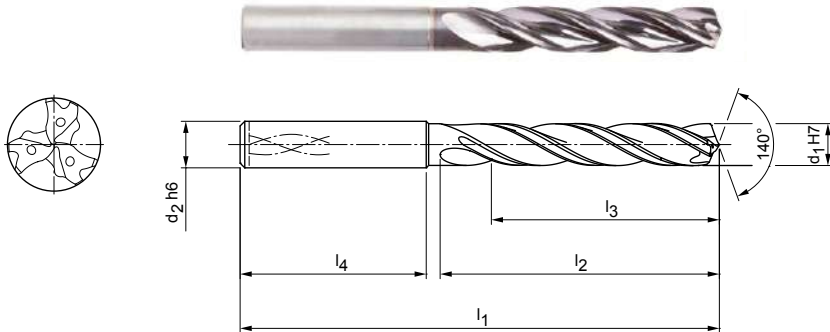

## Lagerhaltige Vorzugsbaureihe in Schaftform HA

Baumaße						Schaftform HA	
d <sub>1</sub> H7	d <sub>2</sub> h6	l <sub>1</sub>	l <sub>2</sub>	l <sub>3</sub>	l <sub>4</sub>	Spezifikation	Bestell-Nr.
4,00	6	74	36	29	36	M9965-4.000H7AR	31196483
5,00	6	82	44	35	36	M9965-5.000H7AR	31196484
6,00	6	82	44	35	36	M9965-6.000H7AR	31196485
8,00	8	91	53	43	36	M9965-8.000H7AR	31196486
10,00	10	103	61	49	40	M9965-10.000H7AR	31196487
12,00	12	118	71	56	45	M9965-12.000H7AR	31196488
14,00	14	124	77	60	45	M9965-14.000H7AR	31196489
16,00	16	133	83	63	48	M9965-16.000H7AR	31196490
18,00	18	143	93	71	48	M9965-18.000H7AR	31196491
20,00	20	153	101	77	50	M9965-20.000H7AR	31196492

Maßangaben in mm.  
Für Passungsbohrungen der Toleranzklasse H7, bei ausreichender Maschinenstabilität und Kühlung.  
Schnittwertempfehlung siehe Kapitelende.  
Sonderausführungen und andere Beschichtungen auf Anfrage.

# Schnittwertempfehlung für Bohrreibahlen

Vorschub und Schnittgeschwindigkeit

## Tritan-Drill-Reamer | M9963, M9965

MZG*	Werkstoff	Festigkeit/Härte [N/mm <sup>2</sup> ] [HRC]
P	P1.1 Bau-, Automaten-, Einsatz- und Vergütungsstähle, unlegiert	< 700
	P1.2 Bau-, Automaten-, Einsatz- und Vergütungsstähle, unlegiert	< 1.200
	P2.1 Nitrier-, Einsatz- und Vergütungsstähle, legiert	< 900
	P2.2 Nitrier-, Einsatz- und Vergütungsstähle, legiert	< 1.400
	P3.1 Werkzeug-, Wälzlager-, Feder- und Schnellarbeitsstähle**	< 800
	P3.2 Werkzeug-, Wälzlager-, Feder- und Schnellarbeitsstähle**	< 1.000
	P3.3 Werkzeug-, Wälzlager-, Feder- und Schnellarbeitsstähle**	< 1.500
	P5.1 Stahlguss	
	K	K1.1 Gusseisen mit Lamellengraphit (Grauguss), GJL
K2.1 Gusseisen mit Kugelgraphit, GJS		< 500
K2.2 Gusseisen mit Kugelgraphit, GJS		≤ 800
K2.3 Gusseisen mit Kugelgraphit, GJS		> 800
K3.1 Gusseisen mit Vermiculargraphit, GJV; Temperguss, GJM		< 500
K3.2 Gusseisen mit Vermiculargraphit, GJV; Temperguss, GJM		> 500

## BERECHNUNGSBEISPIEL

Bitte beachten Sie, dass das Ergebnis von zusätzlichen Parametern wie der Werkzeugmaschine oder der Werkzeugspannung beeinflusst werden kann.

Formel zur Berechnung des optimalen Werkzeugenndurchmessers:

$$(G_{0B} + G_{uB}) / 2$$

Beispiel:

- Passungsbohrung:  $\varnothing 10\ F7$
- Höchstmaß Bohrung  $G_{0B}$ : 10,028 mm
- Mindestmaß Bohrung  $G_{uB}$ : 10,013 mm

→  $(10,028\text{ mm} + 10,013\text{ mm}) / 2 = 10,021\text{ mm} = \text{Auswahl Werkzeugenndurchmesser } 10,021\text{ mm}$

\* MILLER Zerspanungsgruppen

\*\* Wenn die Legierungsbestandteile Cr, Mo, Ni, V, W in Summe > 8 %, dann die nächst höhere MILLER Zerspanungsgruppe wählen.

	Schnittgeschwindigkeit $v_c$ [m/min]				Vorschub $f$ [mm] bei Bohrerdurchmesser					
	Innenkühlung	Außenkühlung	MMS	Luft	4,00	5,50	7,50	10,50	14,50	20,00
	<b>70</b>	<b>65</b>	<b>65</b>		0,17	0,22	0,27	0,34	0,41	0,47
	<b>65</b>	<b>55</b>	<b>55</b>		0,22	0,27	0,34	0,42	0,51	0,59
	<b>70</b>	<b>60</b>	<b>60</b>		0,20	0,26	0,32	0,40	0,48	0,56
	<b>50</b>	<b>40</b>	<b>40</b>		0,17	0,21	0,26	0,32	0,38	0,44
	<b>55</b>	<b>45</b>	<b>45</b>		0,18	0,23	0,29	0,36	0,43	0,50
	<b>40</b>	<b>40</b>	<b>40</b>		0,15	0,19	0,24	0,30	0,36	0,41
	<b>40</b>	<b>30</b>	<b>35</b>		0,13	0,16	0,19	0,23	0,28	0,32
	<b>70</b>	<b>60</b>	<b>60</b>		0,20	0,26	0,32	0,40	0,48	0,56
	<b>100</b>	<b>70</b>	<b>70</b>	<b>70</b>	0,25	0,33	0,42	0,55	0,67	0,79
	<b>135</b>	<b>85</b>	<b>100</b>	<b>100</b>	0,24	0,32	0,40	0,51	0,62	0,72
	<b>85</b>	<b>65</b>	<b>65</b>		0,22	0,28	0,35	0,44	0,54	0,62
	<b>50</b>	<b>35</b>	<b>45</b>		0,11	0,13	0,16	0,20	0,24	0,28
	<b>75</b>	<b>70</b>	<b>70</b>		0,23	0,30	0,38	0,47	0,58	0,67
	<b>70</b>	<b>60</b>	<b>60</b>		0,20	0,25	0,31	0,38	0,46	0,53

Die angegebenen Schnittwerte sind Richtwerte.

Die für den jeweiligen Bearbeitungsfall optimalen Daten sollten im Versuch oder während der Bearbeitung ermittelt werden.

# FRÄSEN

---

Fräser für nahezu alle Anwendungen und Werkstoffe.



# PRODUKTÜBERSICHT

Das leistungsfähige Schafffräserprogramm OptiMill von MILLER sichert bei allen Bearbeitungsaufgaben hervorragende und prozesssichere Ergebnisse. Wirtschaftlichkeit und Produktqualität stehen bei der Erfüllung der Kundenanforderungen besonders im Fokus.

## Anwendungsorientiert

Das Schafffräserprogramm von MILLER umfasst Eckfräser für die universelle Anwendung, zum Schruppen, Schlichten und trochoiden Fräsen sowie Fräser zum Hochvorschubfräsen, Profilfräsen und Fasen.

## Immer die richtige Wahl

Ganz egal ob ein wirtschaftlicher Fräser für die Universalbearbeitung oder ein Experte für eine komplexe Zerspanungsaufgabe gesucht wird – MILLER bietet das passende Werkzeug.



**Basic**  
LINE

**Basic Line:**  
Universalwerkzeuge, breites Anwendungsgebiet, niedrige Anschaffungskosten

**Performance**  
LINE

**Performance Line:**  
Hochleistungswerkzeuge, breites Anwendungsgebiet, hohe Produktivität in der Serienfertigung

**Expert**  
LINE

**Expert Line:**  
Spezialistenwerkzeuge für ausgewählte Anwendungen, maximale Präzision und Produktivität

## Eckfräser



### Universelle Anwendung

Eckfräser für die universelle Anwendung. Eingriffsbreite  $a_e$  bis zu  $1 \times D$ .

- **OptiMill-Uni-HPC-Plus** für die hochwirtschaftliche Universalbearbeitung von Stahl, rostfreiem Stahl und Guss-eisen
- **OptiMill-HPC-Pocket**: Stirmgeometrie mit integrierter Bohrspitze. Ideal für schräges Eintauchen bis  $45^\circ$ , zum Helixfräsen und Stechen
- **OptiMill-SPM** für die Bearbeitung von Strukturbauteilen aus Aluminium

Ø-Bereich: 1,00 - 63,00 mm



### Schruppen

Zum Erreichen höchster Spanvolumen. Ideal zur Vorbearbeitung mit großem Aufmaß. Große Zustellung ( $a_e \sim 0,6 \times D$ ).

- **OptiMill-Uni-HPC-Rough**: Kordelprofil für eine optimierte Kraftaufteilung auf die Schneidkanten und damit bessere Spanbildung
- **OptiMill-Uni-Wave**: Ideal zum Schruppfräsen mit hohen Vorschüben. Geringe Radialkräfte durch neu entwickeltes Schruppprofil
- **OptiMill-SPM-Rough**: Hohe Zustelltiefen sowie höchste Vorschübe beim Schruppen in Aluminium
- **ECU-Mill-Rough&Finish**: Schrupp-Schlichtfräsen in einem Arbeitsgang

Ø-Bereich: 4,00 - 25,00 mm



### Schlichten

Ideal zum Erzeugen von höchsten Oberflächengüten. Fertigbearbeitung mit geringem Aufmaß. Kleine Zustellung ( $a_e \leq 0,1 \times D$ ).

- **OptiMill-Uni-HPC-Finish** mit sieben Schneiden für höchste Oberflächengüten in kürzester Zeit
- **OptiMill-Hardened-Finish** zum Schlichten von Bauteilen mit einer Härte ab 45 HRC
- **OptiMill-SPM-Finish** zum Schlichten von tiefen Taschen und filigranen Bauteilstrukturen in Aluminium auch bei großen Umschlingungen

Ø-Bereich: 4,00 - 25,00 mm

















Eckfräser	Kugel- und Eckradiusfräser	Fas-, Entgrat-, Bohrfräser
		
<p><b>Trochoides Fräsen</b></p> <p>Maximales Zeitspanvolumen bei gleichzeitig hoher Oberflächengüte. Schnitttiefen bis zu 5xD.</p> <p><b>OptiMill-Tro:</b></p> <ul style="list-style-type: none"> <li>- Vor- und Fertigbearbeitung mit einem Werkzeug</li> <li>- Extra langer Schneidteil</li> <li>- Optimierte Ungleichteilung und feingewuchteter Schneidteil für eine Schonung der Maschinenspindel und längere Standzeiten</li> <li>- Spanteiler zur optimalen Spankontrolle</li> </ul> <p>Ø-Bereich: 4,00 - 25,00 mm</p> <p><b>P M K S H</b></p>	<p><b>Hochpräzise Bearbeitung von 3D-Konturen</b></p> <p>Kontur- und Kopierfräsen mit hoher Formgenauigkeit.</p> <ul style="list-style-type: none"> <li>- <b>OptiMill-3D-BN:</b> Hochgenaue Fräser mit hoher Radiusgenauigkeit zur Hart- und Weichbearbeitung von Stahl</li> <li>- <b>OptiMill-3D-CR:</b> Mit unterschiedlicher Zähnezahl verfügbar zum schlichten von 3D-Formen</li> <li>- <b>OptiMill-Composite-Speed-Radius</b> für Reparaturarbeiten von CFK-Strukturen</li> </ul> <p>Ø-Bereich: 1,00 - 25,00 mm</p> <p><b>P M K N C H</b></p>	<p><b>Fasen, Entgraten und Bohrfräsen</b></p> <ul style="list-style-type: none"> <li>- <b>OptiMill-Chamfer:</b> Wirtschaftliches Fasen und Entgraten von vorbearbeiteten Bauteilen</li> <li>- <b>OptiMill-DrillMill:</b> Bohrfräser für eine Kombinationsbearbeitung in einem Arbeitsgang, insbesondere für Bleche und dünnwandige Bauteile</li> </ul> <p>Ø-Bereich: 3,00 - 20,00 mm</p> <p><b>P M K N</b></p>
<p>Seite 421</p>	<p>Seite 445</p>	<p>Seite 499</p>

# AUSWAHL EINES FRÄSERS

## Schritt für Schritt zum richtigen Fräser

Sie suchen zum Beispiel einen Eckfräser für die universelle Anwendung in Stahl mit dem Sie auch rampen können?  
Diese Auswahlhilfe führt Sie Schritt für Schritt zum richtigen Fräser.

1	<b>Fräsertyp</b>	Wählen Sie Ihren Fräsertyp.	➤		Eckfräser - Universelle Anwendung		Eckfräser - Schruppen	
2	<b>Design</b>	Wählen Sie Ihr bevorzugtes Design.	➤		Monolithisch			
3	<b>Produktklasse</b>	Entscheiden Sie sich für eine Produktklasse.	➤					<b>Basic Line:</b> Universalwerkzeuge, breites Anwendungs- gebiet, niedrige Anschaffungskosten
4	<b>Materialeignung</b>	Bestimmen Sie Ihren Werkstückstoff gemäß den MILLER Zerspanungsgruppen (MZG). Die MZG finden Sie auf der Klappseite am Ende des Katalogs.	➤		Stahl		Rostfreier Stahl	
5	<b>Anwendung</b>	Wählen Sie Ihre bevorzugte Anwendung.	➤		Eckfräsen		Nutfräsen	
					Helixfräsen		Trochoides Fräsen	
6	<b>Ausführung</b>	Überprüfen Sie, ob die Geometriemerkmale Ihren Anforderungen entsprechen.	➤		45° Fase		Scharf- kantig	
7	<b>Produkt</b>	Wählen Sie Ihren Fräser. Produkte der lagerhaltigen Vorzugsbaureihe sind kurzfristig lieferbar während Produkte mit konfigurierbaren Merkmalen innerhalb vorgegebener Grenzen frei konfiguriert werden können.	➤					Lagerhaltige Vorzugsbaureihe





Eckfräser - Schlichten



Eckfräser - Trochoides Fräsen



Kugel- und Eckradiusfräser



Fas-, Entgrat- und Bohrfräser



**Performance Line:**  
Hochleistungswerkzeuge, breites Anwendungsgebiet, hohe Produktivität in der Serienfertigung



**Expert Line:**  
Spezialistenwerkzeuge für ausgewählte Anwendungen, maximale Präzision und Produktivität



Gusseisen



Nichteisenmetalle und Kunststoffe

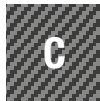

Verbundwerkstoffe



Superlegierungen und Titan



Gehärteter Stahl und Stahlguss

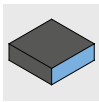

Besäumen

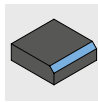

Fasen und Entgraten

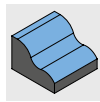

Profilfräsen

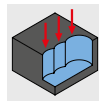

Tauchfräsen / Stechfräsen

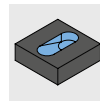

Rampen

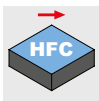

Hochvorschubfräsen

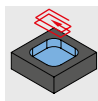

Taschenfräsen / Auskammern



Eckenradius

Durchmesserbereich

Zähnezahl

Schneidstoff

Kühlmittelezufuhr



Produkt mit konfigurierbaren Merkmalen



# Eckfräser - Universelle Anwendung

Design	Pro- dukt- klasse	Materialeignung																		Anwendung																																							
		P						M		K		N				C		S		H																																							
		1-3	4	5	6	1-3	1-3	1	2	3	4	2	4	1-5	1	2	3	1	2	3	1	2	3	4	5	6	7	8	9	10	11	12																											
Performance LINE		■	■	■	■	■	■								■												★	■	■							■	■	■		■																			
		■	■	■	■	■	■									■												■	■	■							■	■	■		■																		
		■	■	■	■	■	■									■												■	■	■								■	■	■		■																	
		■	■	■	■	■	■									■												■	■	■									■	■	■		■																
		■	■	■	■	■	■									■												■	■	■										■	■	■		■															
																	■												■	■	■											■	■	■		■													
		■	■	■	■	■	■																						■	■	■										■	■	■		■														
		■	■	■	■	■	■																					■	■	■												■	■	■		■													
																		■											■	■	■												■	■	■		■												
																													■	■	■														■	■	■		■										
																													■	■	■															■	■	■		■									
																												■	■	■																	■	■	■		■								
																													■	■	■																	■	■	■		■							
																														■	■	■																	■	■	■		■						
		Expert LINE		■	■	■	■	■																						■	■	■																		■	■	■		■					
																														■	■	■																						■	■	■		■	
																															■	■	■																						■	■	■		■
		Basic LINE		■	■	■	■	■	■																					■	■	■																						■	■	■		■	
																													■	■	■																								■	■	■		■
																													■	■	■																									■	■	■	

★ 1. Wahl

■ bestens geeignet

■ bedingt geeignet

Schritt 1:  
Fräser typ



Schritt 2:  
Design



Schritt 3:  
Produktklasse



Schritt 4:  
Materialeignung



Schritt 5:  
Anwendung

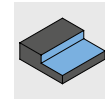

Schritt 6:  
Ausführung



Kantenausführung			Ausführung				Produkt			
45°	90°	CR	Ø [mm]	z	Mat.		Produktname	Spezifikation		Seite
✓		✓	2,5-25	4	HP		OptiMill-Uni-HPC-Plus	M3190P, M3194P, M3090P, M3094P		324
✓			1-20	2	HP		OptiMill-Uni-HPC-Plus	M3092P		331
✓	✓		1-20	3	HP		OptiMill-Uni-HPC-Slot	M3293		332
		✓	3,8-20	3	HP		OptiMill-Uni-HPC-Pocket	M3991, M3993, M3990		333
✓			6-25	5	HP		OptiMill-Uni-HPC-Silent	M3095		336
		✓	4-20	4	HP		OptiMill-Hardened	M3274, M3271		339
✓			3-20	4	HP		OptiMill-Inox-HPC	M3644		341
		✓	6-25	4	HP		OptiMill-Titan-HPC	M3614		342
✓			3-20	3	HU		OptiMill-Alu-HPC	M3493		343
		✓	5-20	3	HP		OptiMill-Alu-HPC-Pocket	M3413		344
		✓	5-20	4	HP		OptiMill-Alu-HPC-Pocket	M3414		345
✓			6-20	4	HC		OptiMill-Thermoplastic-FR	M7644		355
✓			4-20	8	HU		OptiMill-Composite-Speed-Plus	M7248P, M7258P		348
	✓		1-3	VZ	HC		OptiMill-Composite-Micro	M7901		352
✓			3-20	2	HC		OptiMill-Composite-Duo	M7222		353
	✓		4-20	2	HU		OptiMill-Composite-TwinCut	M7402		354
		✓	12-32	3	HU	✓	OptiMill-SPM	M3593, M3591		346
✓			4-20	8	HC		OptiMill-Composite-Speed-Plus	M7228P, M7238P		350
✓			3-20	4	HP		ECU-Mill-Uni-LV	M4090, M4094		337
	✓	✓	2-10	1	HU		OptiMill-Mono-Alu	MN7MA		347
	✓		2-12	1	HU		OptiMill-Mono-Plastic	MN7MP		356

## Eckfräser - Schruppen

Design	Produkt-klasse	Materialeignung												Anwendung																	
		P				M		K		N				C		S		H			Anwendung										
		1-3	4	5	6	1-3	1-3	1	2	3	4	1	2	4	1-5	1	2	3													
	Performance LINE	■	■	■	■	■	■								■	■			★	■	■				■	■	■		■		
	Expert LINE									■									★	■	■			■	■	■	■	■			
	Basic LINE	■	■	■	■	■	■	■	■										■	■	■				■	■	■		■		

## Eckfräser - Schlichten

Design	Produkt-klasse	Materialeignung												Anwendung																	
		P				M		K		N				C		S		H			Anwendung										
		1-3	4	5	6	1-3	1-3	1	2	3	4	1	2	4	1-5	1	2	3													
	Performance LINE	■	■	■	■	■	■								■	■			■		■										
	Expert LINE																				■										
	Basic LINE																		■	■											

## Eckfräser - Trochoides Fräsen

Design	Produkt-klasse	Materialeignung												Anwendung																	
		P				M		K		N				C		S		H			Anwendung										
		1-3	4	5	6	1-3	1-3	1	2	3	4	1	2	4	1-5	1	2	3													
	Expert LINE	■	■	■	■	■	■								■	■			■		■			■	■	★		■			
	Basic LINE																				■					★		■			
	Basic LINE																				■					★		■			
	Basic LINE																				■					★		■			
	Basic LINE																		■	■						★		■			

★ 1. Wahl   ■ bestens geeignet   ◻ bedingt geeignet

Schritt 1:  
Fräser typ



Schritt 2:  
Design



Schritt 3:  
Produktklasse



Schritt 4:  
Materialeignung



Schritt 5:  
Anwendung

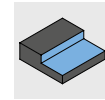

Schritt 6:  
Ausführung



Kantenausführung			Ausführung				Produkt			
45°	90°	CR	∅ [mm]	z	Mat.		Produktname	Spezifikation		Seite
✓			4-25	3-5	HP		OptiMill-Uni-HPC-Rough	M3081, M3181		382
✓			4-25	5	HP	✓	OptiMill-Uni-Wave	M3980, M3985, M3185, M3981, M3982		384
		✓	12-25	3	HU	✓	OptiMill-SPM-Rough	M3583		392
✓	✓		6-20	3-4	HP		ECU-Mill-Uni-Rough&Finish	M3060		393

Kantenausführung			Ausführung				Produkt			
45°	90°	CR	∅ [mm]	z	Mat.		Produktname	Spezifikation		Seite
✓	✓		4-25	7	HP		OptiMill-Uni-HPC-Finish	M3917		404
	✓		6-20	6	HP		OptiMill-Uni-HPC-Finish	M3096		408
	✓	✓	4-25	6	HP		OptiMill-Hardened-Finish	M3276, M3272		409
		✓	12-25	4	HU		OptiMill-SPM-Finish	M3434		414

Kantenausführung			Ausführung				Produkt			
45°	90°	CR	∅ [mm]	z	Mat.		Produktname	Spezifikation		Seite
✓			4-20	5	HP		OptiMill-Tro-Uni	M3099		422
✓			4-25	5	HP		OptiMill-Tro-PM	M3299		425
✓			4-25	7	HP		OptiMill-Tro-PM	M3299		426
		✓	6-25	5	HP		OptiMill-Tro-Titan	M3799		432
✓			4-25	6	HP		OptiMill-Tro-Inox	M3399		433
		✓	6-25	5	HP		OptiMill-Tro-S	M3699		431
		✓	6-25	5	HP		OptiMill-Tro-H	M3079		430



Schritt 1:  
Fräser typ



Schritt 2:  
Design



Schritt 3:  
Produktklasse



Schritt 4:  
Materialeignung



Schritt 5:  
Anwendung

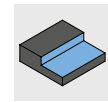

Schritt 6:  
Ausführung



Kantenausführung				Ausführung				Produkt			
45°	90°	CR	∅ [mm]	z	Mat.		Produktname	Spezifikation		Seite	
			1-12	2	HP		OptiMill-3D-BN	TBN101		446	
			3-12	4	HP		OptiMill-3D-BN	TBN104		447	
			3-12	2	HP		OptiMill-3D-BN-Hardened	TBN107		448	
			3-16	4	VHM		OptiMill-3D-BN-Hardened	TBN109		449	
			1-20	2	VHM		OptiMill-3D-BN-Alu	TBN114, 116		450	
			0,1-12	2	VHM		OptiMill-3D-CR	TCR101		454	
			3-12	4	VHM		OptiMill-3D-CR	TCR104		458	
			0,1-12	2	VHM		OptiMill-3D-CR-Hardened	TCR107		460	
			3-12	4	VHM		OptiMill-3D-CR-Hardened	TCR109		464	
			2-20	2	VHM		OptiMill-3D-CR-Alu	TCR120		466	
			4-20	8	HC		OptiMill-Composite-Speed-Radius	M7828		467	

Kantenausführung				Ausführung				Produkt			
45°	90°	CR	∅ [mm]	z	Mat.		Produktname	Spezifikation		Seite	
			4-20	4	HP		OptiMill-Chamfer	M5390		500	
			3-16	2	HU		OptiMill-DrillMill	M5490		501	

# Bezeichnungsschlüssel

## Vollhartmetall-Schaftfräser

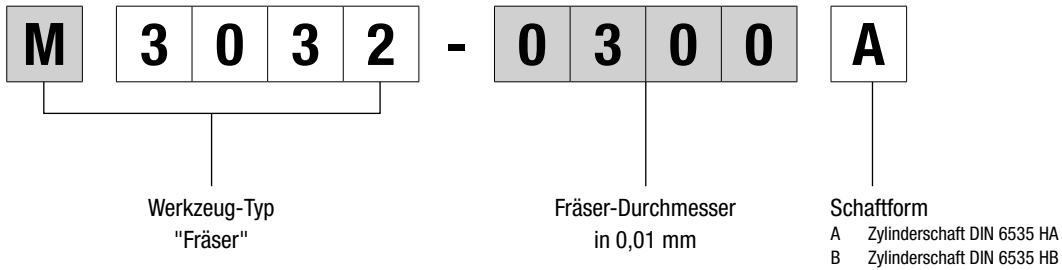

## Schaftfräser für den Werkzeug- und Formenbau

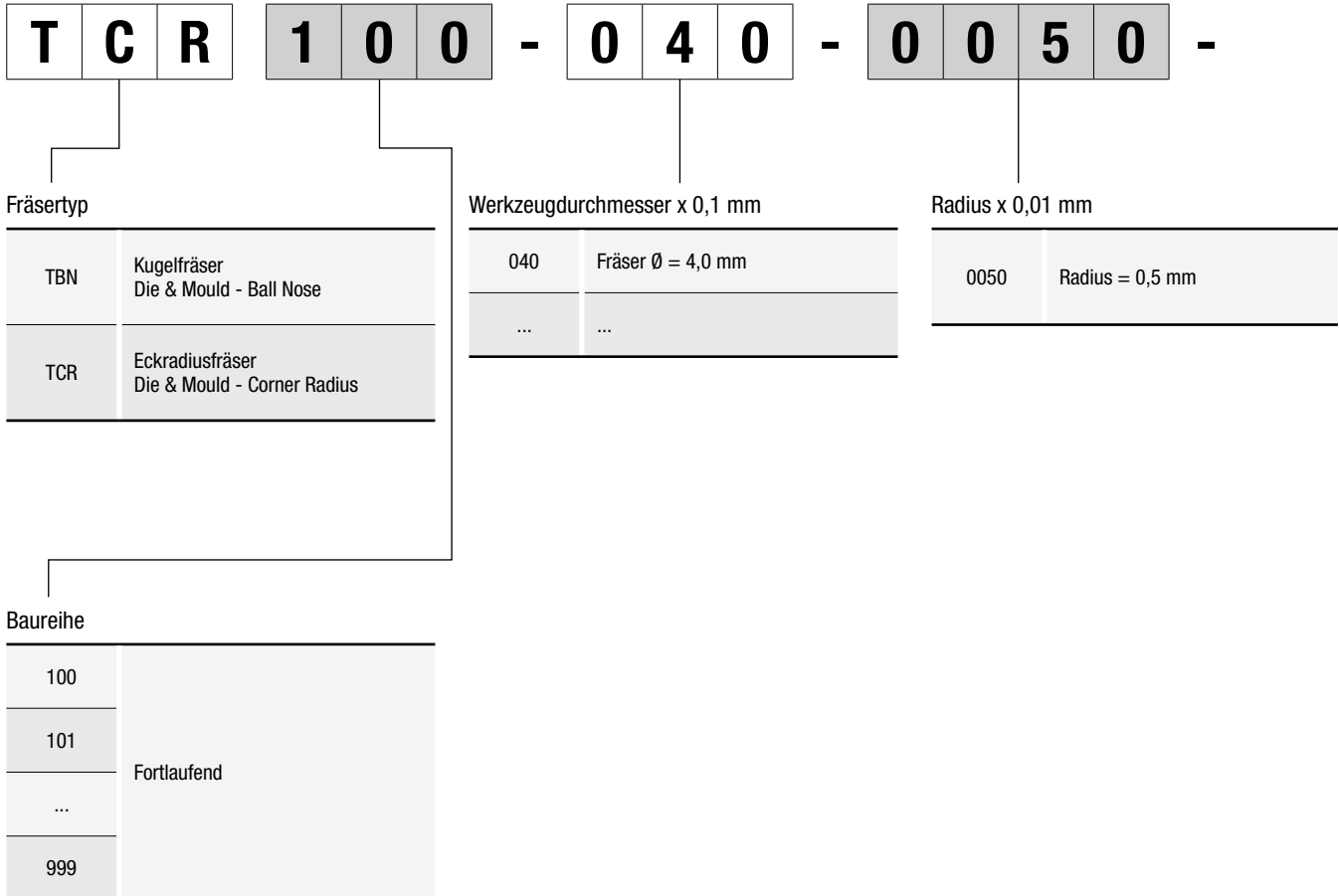



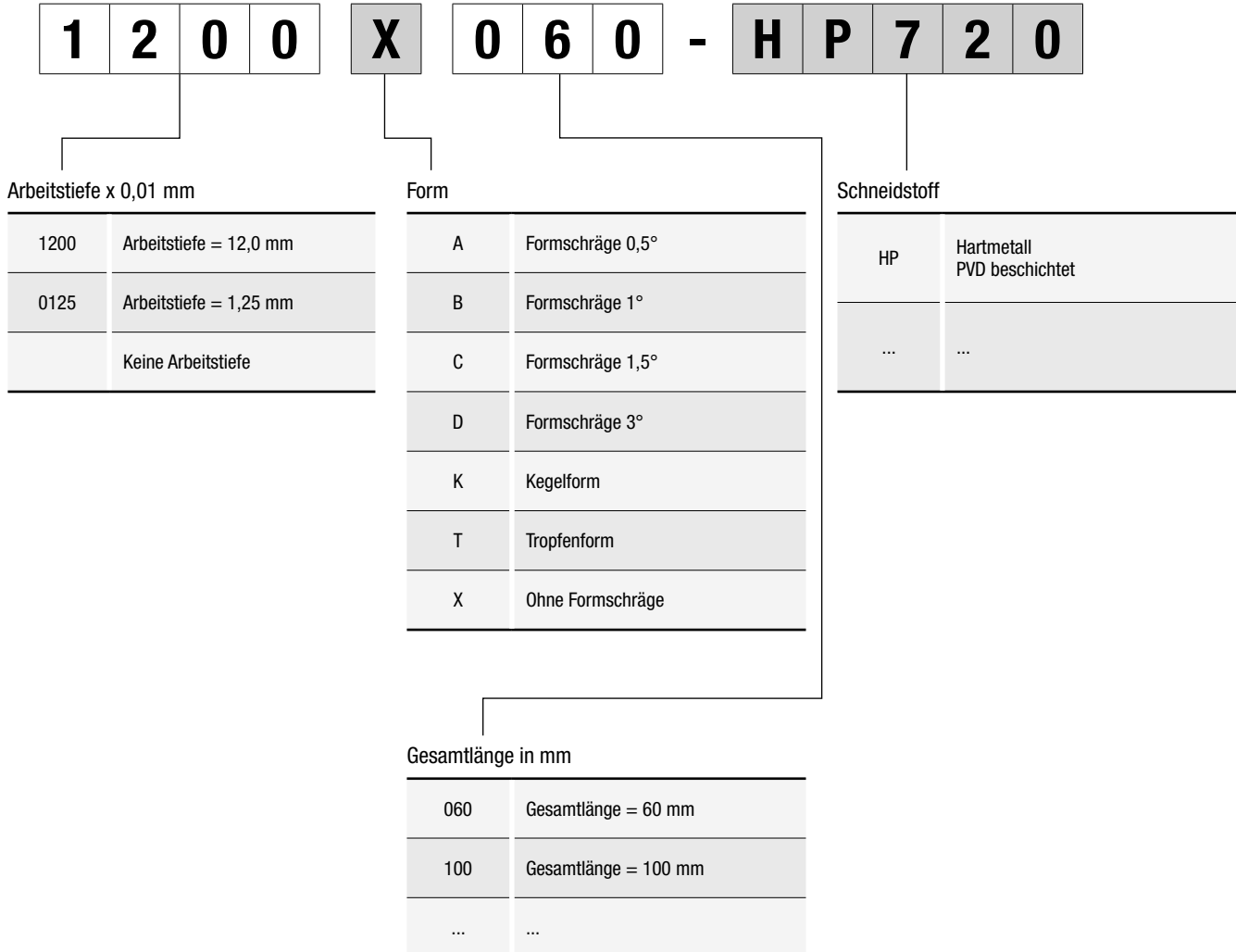
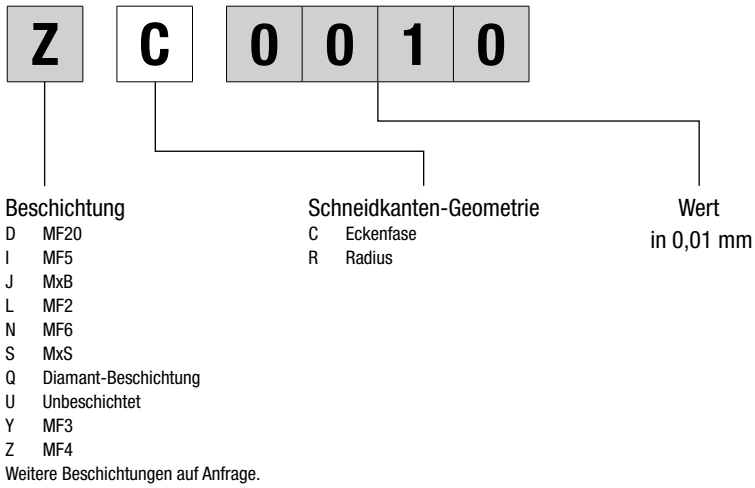



# ECKFRÄSER – UNIVERSELLE BEARBEITUNG



## Universeller Einsatz

---

OptiMill-Uni-HPC-Plus .....	324
OptiMill-Uni-HPC-Slot .....	332
OptiMill-Uni-HPC-Pocket .....	333
OptiMill-Uni-HPC-Silent .....	336
ECU-Mill-Uni-LV .....	337

## Gehärteter Stahl

---

OptiMill-Hardened .....	339
-------------------------	-----

## Inox und Titan

---

OptiMill-Inox-HPC .....	341
OptiMill-Titan-HPC .....	342

## Nichteisenmetalle

---

OptiMill-Alu-HPC .....	343
OptiMill-Alu-HPC-Pocket .....	344
OptiMill-SPM .....	346
OptiMill-Mono-Alu .....	347

## Kunststoffe und Verbundwerkstoffe

---

OptiMill-Thermoplastic-FR .....	355
OptiMill-Composite-Speed-Plus .....	348
OptiMill-Composite-Micro .....	352
OptiMill-Composite-Duo .....	353
OptiMill-Composite-TwinCut .....	354
OptiMill-Mono-Plastic .....	356

## Technischer Anhang

---

Schnittwertempfehlung .....	358
-----------------------------	-----

# OptiMill®-Uni-HPC-Plus

Eckfräser, kurze Ausführung  
M3090P

**Ausführung:**

Fräserdurchmesser: 3,00 - 20,00 mm  
 Beschichtung: MF2  
 Schneidzahl: 4  
 Spiralwinkel: 36°/38°  
 Besonderheiten: Ungleichteilung, Schneidkantenverrundung

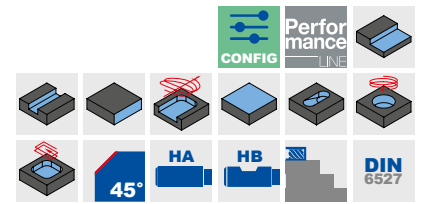
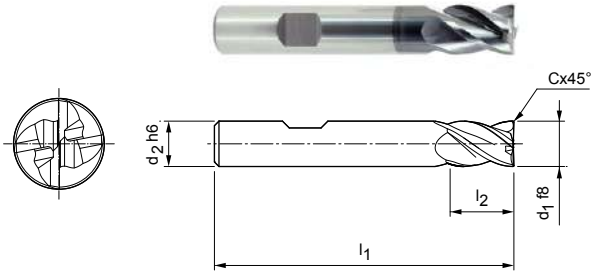

**Lagerhaltige Vorzugsbaureihe**

Baumaße					z	Spezifikation	Bestell-Nr.
d <sub>1</sub> f8	d <sub>2</sub> h6	l <sub>1</sub>	l <sub>2</sub>	Cx45°			
3,00	6	50	6	0,06	4	M3090P-0300BL	30673398
4,00	6	54	8	0,08	4	M3090P-0400BL	30673399
5,00	6	54	9	0,10	4	M3090P-0500BL	30673400
6,00	6	54	10	0,12	4	M3090P-0600BL	30673401
8,00	8	58	12	0,16	4	M3090P-0800BL	30673402
10,00	10	66	14	0,20	4	M3090P-1000BL	30673403
12,00	12	73	16	0,24	4	M3090P-1200BL	30673404
14,00	14	73	16	0,28	4	M3090P-1400BL	30673405
16,00	16	82	22	0,32	4	M3090P-1600BL	30673406
18,00	18	82	22	0,36	4	M3090P-1800BL	30673407
20,00	20	92	26	0,40	4	M3090P-2000BL	30673408

**Konfigurierbare Merkmale**



**Schaftform:**  
Schaftform: HA



**Spezifikation:**  
M3090P-1200[Schaftform]L

**Beispiel:**  
M3090P-1200AL

Schaftform HA

Maßangaben in mm.  
 Schnittwertempfehlung siehe Kapitelende.  
 Sonderausführungen und andere Beschichtungen auf Anfrage.

# OptiMill®-Uni-HPC-Plus

Eckfräser, lange Ausführung mit Hals, Ausführung mit Fase / kleiner Fase  
M3094P

**Ausführung:**

Fräserdurchmesser: 2,50 - 25,00 mm  
 Beschichtung: MF2  
 Schneidenzahl: 4  
 Spiralwinkel: 36°/38°  
 Besonderheiten: Ungleichteilung, Schneidkantenverrundung

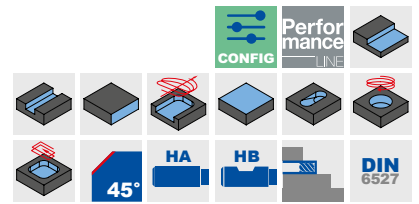
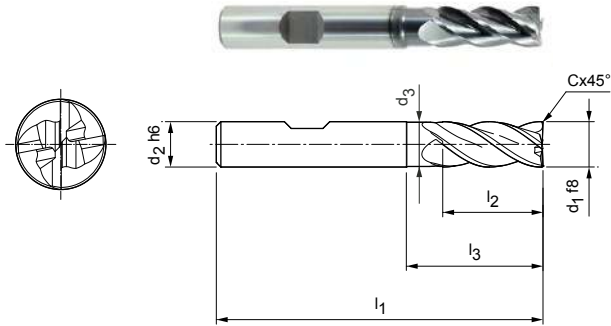

**Ausführung mit Fase | Lagerhaltige Vorzugsbaureihe**

Baumaße							z	Spezifikation	Bestell-Nr.
d1 f8	d2 h6	d3	l1	l2	l3	Cx45°			
2,50*	6	–	57	8	–	0,05	4	M3094P-0250BL	30673409
3,00*	6	–	57	8	–	0,06	4	M3094P-0300BL	30673410
4,00*	6	–	57	11	–	0,08	4	M3094P-0400BL	30673411
5,00*	6	–	57	13	–	0,10	4	M3094P-0500BL	30673412
6,00	6	5,8	57	13	20	0,12	4	M3094P-0600BL	30673413
7,00	8	6,8	63	16	25	0,14	4	M3094P-0700BL	30673414
8,00	8	7,8	63	21	25	0,16	4	M3094P-0800BL	30673415
9,00	10	8,8	72	22	30	0,18	4	M3094P-0900BL	30673416
10,00	10	9,8	72	22	30	0,20	4	M3094P-1000BL	30673417
12,00	12	11,8	83	26	36	0,24	4	M3094P-1200BL	30673418
14,00	14	13,8	83	26	36	0,28	4	M3094P-1400BL	30673419
16,00	16	15,8	92	36	42	0,32	4	M3094P-1600BL	30673420
18,00	18	17,8	92	36	47	0,36	4	M3094P-1800BL	30673421
20,00	20	19,8	104	41	55	0,40	4	M3094P-2000BL	30673422
25,00	25	24,5	136	68	80	0,50	4	M3094P-2500BL	30673423

**Ausführung mit kleiner Fase | Lagerhaltige Vorzugsbaureihe**

6,00	6	5,8	57	13	20	0,10	4	M3094P-0600BL-C0010	31179849
8,00	8	7,8	63	21	25	0,10	4	M3094P-0800BL-C0010	31179870
10,00	10	9,8	72	22	30	0,10	4	M3094P-1000BL-C0010	31179872
12,00	12	11,8	83	26	36	0,10	4	M3094P-1200BL-C0010	31179873
14,00	14	13,8	83	26	36	0,10	4	M3094P-1400BL-C0010	31179874
16,00	16	15,8	92	36	42	0,10	4	M3094P-1600BL-C0010	31179875
20,00	20	19,8	104	41	55	0,10	4	M3094P-2000BL-C0010	31179876

**Konfigurierbare Merkmale**



**Schaftform:**  
Schaftform: HA



**Spezifikation:**  
M3094P-1200[**Schaftform**]L

**Beispiel:**  
M3094P-1200AL



Maßangaben in mm.  
 \* Ausführung ohne Hals.  
 Schnittwertempfehlung siehe Kapitelende.  
 Sonderausführungen und andere Beschichtungen auf Anfrage.

# OptiMill®-Uni-HPC-Plus

Eckfräser, lange Ausführung mit Hals, Ausführung mit Eckenradius M3094P

**Ausführung:**

Fräserdurchmesser: 2,50 - 25,00 mm  
 Beschichtung: MF2  
 Schneidzahl: 4  
 Spiralwinkel: 36°/38°  
 Besonderheiten: Ungleichteilung, Schneidkantenverrundung

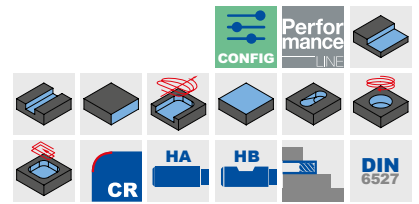
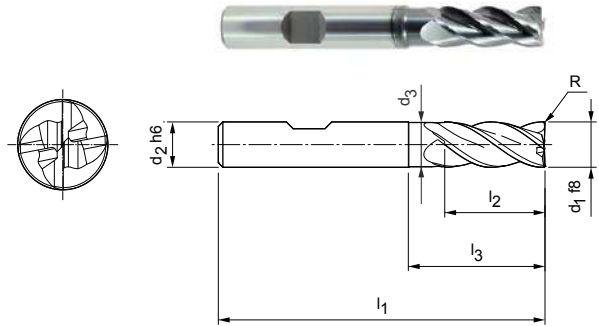

**Ausführung mit Radius | Lagerhaltige Vorzugsbaureihe**

Baumaße							z	Spezifikation	Bestell-Nr.
d1 f8	d2 h6	d3	l1	l2	l3	R			
4,00*	6	–	57	11	–	0,4	4	M3094P-0400BL-R0040	30782243
4,00*	6	–	57	11	–	0,5	4	M3094P-0400BL-R0050	30782244
4,00*	6	–	57	11	–	1	4	M3094P-0400BL-R0100	30782245
5,00*	6	–	57	13	–	0,5	4	M3094P-0500BL-R0050	30782246
5,00*	6	–	57	13	–	1	4	M3094P-0500BL-R0100	30782247
6,00	6	5,8	57	13	20	0,5	4	M3094P-0600BL-R0050	30782248
6,00	6	5,8	57	13	20	1	4	M3094P-0600BL-R0100	30782249
6,00	6	5,8	57	13	20	1,5	4	M3094P-0600BL-R0150	30782250
6,00	6	5,8	57	13	20	2	4	M3094P-0600BL-R0200	30782251
8,00	8	7,8	63	21	25	0,5	4	M3094P-0800BL-R0050	30782252
8,00	8	7,8	63	21	25	1	4	M3094P-0800BL-R0100	30782253
8,00	8	7,8	63	21	25	1,5	4	M3094P-0800BL-R0150	30782254
8,00	8	7,8	63	21	25	2	4	M3094P-0800BL-R0200	30782255
8,00	8	7,8	63	21	25	2,5	4	M3094P-0800BL-R0250	30782256
8,00	8	7,8	63	21	25	3	4	M3094P-0800BL-R0300	30782257
10,00	10	9,8	72	22	30	0,5	4	M3094P-1000BL-R0050	30782258
10,00	10	9,8	72	22	30	1	4	M3094P-1000BL-R0100	30782259
10,00	10	9,8	72	22	30	1,5	4	M3094P-1000BL-R0150	30782260
10,00	10	9,8	72	22	30	2	4	M3094P-1000BL-R0200	30782261
10,00	10	9,8	72	22	30	2,5	4	M3094P-1000BL-R0250	30782262
10,00	10	9,8	72	22	30	3	4	M3094P-1000BL-R0300	30782263
12,00	12	11,8	83	26	36	0,5	4	M3094P-1200BL-R0050	30782264
12,00	12	11,8	83	26	36	1	4	M3094P-1200BL-R0100	30782265
12,00	12	11,8	83	26	36	1,5	4	M3094P-1200BL-R0150	30782266
12,00	12	11,8	83	26	36	2	4	M3094P-1200BL-R0200	30782267
12,00	12	11,8	83	26	36	2,5	4	M3094P-1200BL-R0250	30782268
12,00	12	11,8	83	26	36	3	4	M3094P-1200BL-R0300	30782269
12,00	12	11,8	83	26	36	4	4	M3094P-1200BL-R0400	30782270
16,00	16	15,8	92	36	42	0,5	4	M3094P-1600BL-R0050	30782271
16,00	16	15,8	92	36	42	1	4	M3094P-1600BL-R0100	30782272
16,00	16	15,8	92	36	42	2	4	M3094P-1600BL-R0200	30782273
16,00	16	15,8	92	36	42	2,5	4	M3094P-1600BL-R0250	30782274
16,00	16	15,8	92	36	42	3	4	M3094P-1600BL-R0300	30782275
16,00	16	15,8	92	36	42	4	4	M3094P-1600BL-R0400	30782276
20,00	20	19,8	104	41	52	1	4	M3094P-2000BL-R0100	30782277

**Ausführung mit Radius | Lagerhaltige Vorzugsbaureihe**

Baumaße							z	Spezifikation	Bestell-Nr.
d <sub>1</sub> f8	d <sub>2</sub> h6	d <sub>3</sub>	l <sub>1</sub>	l <sub>2</sub>	l <sub>3</sub>	R			
20,00	20	19,8	104	41	52	2	4	M3094P-2000BL-R0200	30782278
20,00	20	19,8	104	41	52	3	4	M3094P-2000BL-R0300	30782279
20,00	20	19,8	104	41	52	4	4	M3094P-2000BL-R0400	30782280

**Konfigurierbare Merkmale**



**Schafform:**  
Schafform: HA



**Spezifikation:**  
M3094P-1200[Schafform]L-R0050

**Beispiel:**  
M3094P-1200AL-R0050

Schafform HA

Maßangaben in mm.

\* Ausführung ohne Hals.

Schnittwertempfehlung siehe Kapitelende.

Sonderausführungen und andere Beschichtungen auf Anfrage.

# OptiMill®-Uni-HPC-Plus

Eckfräser, überlange Ausführung mit Hals, Ausführung mit Fase  
M3190P

**Ausführung:**

Fräserdurchmesser: 5,00 - 25,00 mm  
 Beschichtung: MF2  
 Schneidzahl: 4  
 Spiralwinkel: 36°/38°  
 Besonderheiten: Ungleichteilung, Schneidkantenverrundung

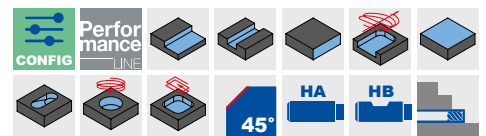
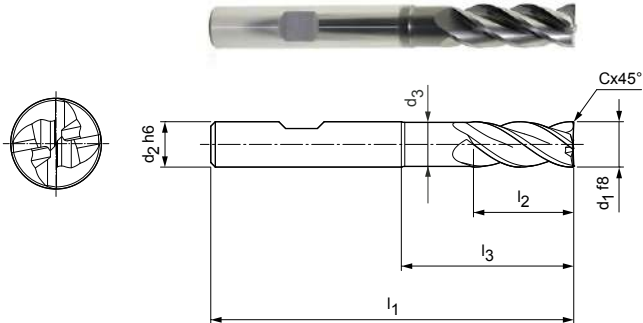

**Lagerhaltige Vorzugsbaureihe**

Baumaße							z	Spezifikation	Bestell-Nr.
d1 f8	d2 h6	d3	l1	l2	l3	Cx45°			
6,00	6	5,8	62	13	25	0,12	4	M3190P-0600BL-C0012	30636585
8,00	8	7,7	68	21	30	0,16	4	M3190P-0800BL-C0016	30636586
10,00	10	9,7	80	22	38	0,20	4	M3190P-1000BL-C0020	30636588
12,00	12	11,6	93	26	46	0,24	4	M3190P-1200BL-C0024	30636590
14,00	14	13,6	99	26	52	0,28	4	M3190P-1400BL-C0028	30636591
16,00	16	15,5	108	36	58	0,32	4	M3190P-1600BL-C0032	30636592
18,00	18	17,5	117	36	67	0,36	4	M3190P-1800BL-C0036	30651264
20,00	20	19,5	126	41	74	0,40	4	M3190P-2000BL-C0040	30636594
25,00	25	24	150	50	92	0,50	4	M3190P-2500BL-C0050	30636595

**Auf Anfrage erhältlich**

5,00	6	4,8	62	13	24	0,10	4	M3190P-0500BL-C0010	30636550
------	---	-----	----	----	----	------	---	---------------------	----------

**Konfigurierbare Merkmale**



**Schaftform:**  
Schaftform: HA



**Spezifikation:**  
M3190P-1200[**Schaftform**]L-C0024

**Beispiel:**

M3190P-1200AL-C0024

\_\_\_\_\_ Schaftform HA

Maßangaben in mm.

Schnittwertempfehlung siehe Kapitelende.

Sonderausführungen und andere Beschichtungen auf Anfrage.



# OptiMill®-Uni-HPC-Plus

Eckfräser, überlange Ausführung mit Hals, Ausführung mit Eckenradius  
M3190P

**Ausführung:**  
Fräserdurchmesser: 4,00 - 25,00 mm  
Beschichtung: MF2  
Schneidzahl: 4  
Spiralwinkel: 36°/38°  
Besonderheiten: Ungleichteilung, Schneidkantenverrundung

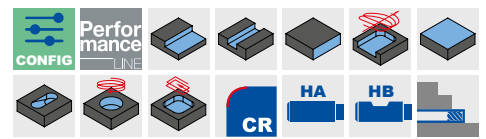
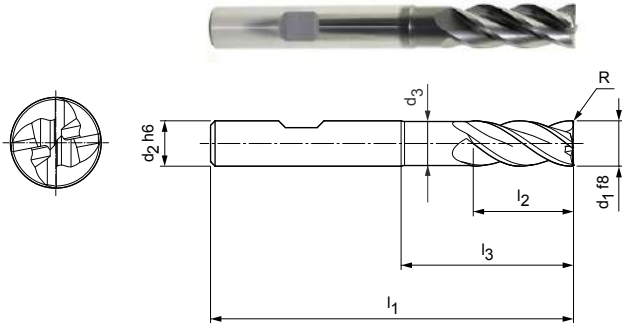

## Lagerhaltige Vorzugsbaureihe

Baumaße							z	Spezifikation	Bestell-Nr.
d1 f8	d2 h6	d3	l1	l2	l3	R			
4,00	6	3,8	62	11	22	0,5	4	M3190P-0400BL-R0050	30982886
4,00	6	3,8	62	11	22	1	4	M3190P-0400BL-R0100	30982887
5,00	6	4,8	62	13	24	0,5	4	M3190P-0500BL-R0050	30982888
5,00	6	4,8	62	13	24	1	4	M3190P-0500BL-R0100	30982889
6,00	6	5,8	62	13	25	0,5	4	M3190P-0600BL-R0050	30982890
6,00	6	5,8	62	13	25	1	4	M3190P-0600BL-R0100	30982891
6,00	6	5,8	62	13	25	2	4	M3190P-0600BL-R0200	30982892
8,00	8	7,7	68	21	30	1	4	M3190P-0800BL-R0100	30982893
8,00	8	7,7	68	21	30	2	4	M3190P-0800BL-R0200	30982894
10,00	10	9,7	80	22	38	0,5	4	M3190P-1000BL-R0050	30982895
10,00	10	9,7	80	22	38	1	4	M3190P-1000BL-R0100	30982896
10,00	10	9,7	80	22	38	1,5	4	M3190P-1000BL-R0150	30982897
10,00	10	9,7	80	22	38	2	4	M3190P-1000BL-R0200	30982898
10,00	10	9,7	80	22	38	3	4	M3190P-1000BL-R0300	30982899
12,00	12	11,6	93	26	46	0,5	4	M3190P-1200BL-R0050	30982900
12,00	12	11,6	93	26	46	1	4	M3190P-1200BL-R0100	30982901
12,00	12	11,6	93	26	46	1,5	4	M3190P-1200BL-R0150	30982902
12,00	12	11,6	93	26	46	2	4	M3190P-1200BL-R0200	30982903
12,00	12	11,6	93	26	46	3	4	M3190P-1200BL-R0300	30982904
16,00	16	15,5	108	36	58	0,5	4	M3190P-1600BL-R0050	30982905
16,00	16	15,5	108	36	58	1	4	M3190P-1600BL-R0100	30982906
16,00	16	15,5	108	36	58	2	4	M3190P-1600BL-R0200	30982907
16,00	16	15,5	108	36	58	4	4	M3190P-1600BL-R0400	30982908
20,00	20	19,5	126	41	74	1	4	M3190P-2000BL-R0100	30982909
20,00	20	19,5	126	41	74	2	4	M3190P-2000BL-R0200	30982910
20,00	20	19,5	126	41	74	4	4	M3190P-2000BL-R0400	30982911

## Konfigurierbare Merkmale

**Schaftform:**  
Schaftform: HA

**Spezifikation:**  
M3190P-1200[**Schaftform**]L-R0050

**Beispiel:**  
M3190P-1200AL-R0050

Schaftform HA

Maßangaben in mm.  
\* Ausführung ohne Hals.  
Schnittwertempfehlung siehe Kapitelende.  
Sonderausführungen und andere Beschichtungen auf Anfrage.

# OptiMill®-Uni-HPC-Plus

Eckfräser, extra lange Ausführung mit Hals  
M3194P

**Ausführung:**

Fräserdurchmesser: 5,00 - 25,00 mm  
 Beschichtung: MF2  
 Schneidenzahl: 4  
 Spiralwinkel: 36°/38°  
 Besonderheiten: Ungleichteilung, Schneidkantenverrundung

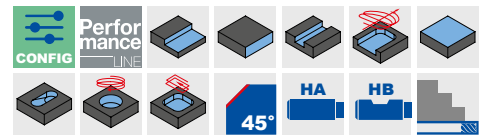
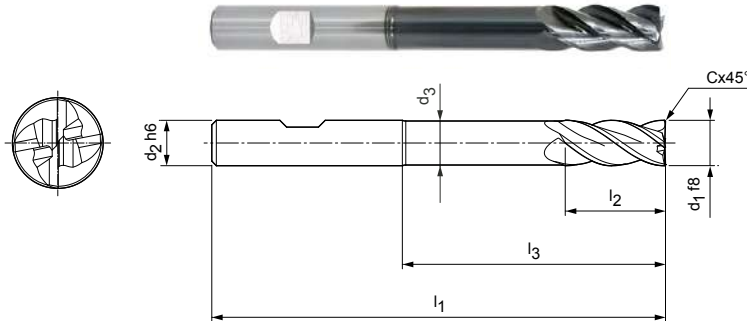

**Lagerhaltige Vorzugsbaureihe**

Baumaße							z	Spezifikation	Bestell-Nr.
d1 f8	d2 h6	d3	l1	l2	l3	Cx45°			
5,00	6	4,8	80	13	41	0,10	4	M3194P-0500BL	30652455
6,00	6	5,8	80	13	42	0,12	4	M3194P-0600BL	30652456
8,00	8	7,7	100	21	62	0,16	4	M3194P-0800BL	30652457
10,00	10	9,7	100	22	58	0,20	4	M3194P-1000BL	30652458
12,00	12	11,6	120	26	73	0,24	4	M3194P-1200BL	30652459
14,00	14	13,6	120	26	73	0,28	4	M3194P-1400BL	30652461
16,00	16	15,5	150	36	100	0,32	4	M3194P-1600BL	30652462
20,00	20	19,5	150	41	98	0,40	4	M3194P-2000BL	30652464

**Auf Anfrage erhältlich**

18,00	18	17,5	150	36	100	0,36	4	M3194P-1800BL	30652463
25,00	25	24	175	50	117	0,50	4	M3194P-2500BL	30652465

**Konfigurierbare Merkmale**



**Schaftform:**  
Schaftform: HA



**Spezifikation:**  
M3194P-1200[Schaftform]L

**Beispiel:**  
M3194P-1200AL

Schaftform HA

Maßangaben in mm.  
 Schnittwertempfehlung siehe Kapitelende.  
 Sonderausführungen und andere Beschichtungen auf Anfrage.

# OptiMill®-Uni-HPC-Plus

Eckfräser, lange Ausführung mit Hals  
M3092P

**Ausführung:**  
Fräserdurchmesser: 1,00 - 20,00 mm  
Beschichtung: MF2/MF3  
Schneidenzahl: 2  
Spiralwinkel: 36°/38°  
Besonderheiten: Ungleichteilung,  
Schneidkanten-  
verrundung

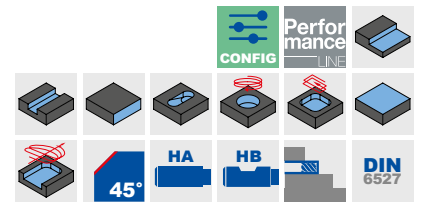
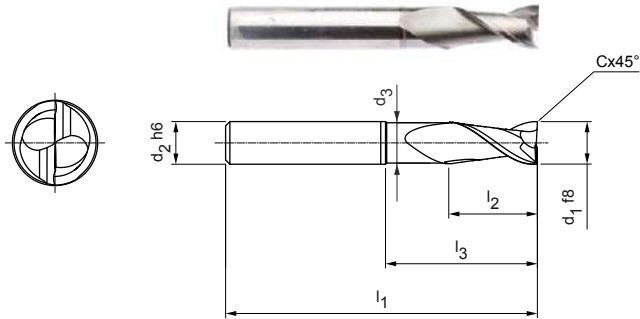

## Lagerhaltige Vorzugsbaureihe

Baumaße							z	Spezifikation	Bestell-Nr.
d1 f8	d2 h6	d3	l1	l2	l3	Cx45°			
1,00	3	0,97	38	3	5	0,025	2	M3092P-0100AY-C00025	31205153
2,00	3	1,9	38	4	8	0,05	2	M3092P-0200AY-C0005	31205154
3,00	6	2,8	57	7	13	0,10	2	M3092P-0300AL-C0010	31205155
4,00	6	3,8	57	8	14	0,10	2	M3092P-0400AL-C0010	31205156
5,00	6	4,8	57	10	15,5	0,10	2	M3092P-0500AL-C0010	31205157
6,00	6	5,8	57	10	20	0,10	2	M3092P-0600AL-C0010	31205158
8,00	8	7,8	63	16	25	0,10	2	M3092P-0800AL-C0010	31205159
10,00	10	9,8	72	19	30	0,10	2	M3092P-1000AL-C0010	31205170
12,00	12	11,8	83	22	36	0,10	2	M3092P-1200AL-C0010	31205171
16,00	16	15,8	92	26	42	0,10	2	M3092P-1600AL-C0010	31205172

## Auf Anfrage erhältlich

20,00	20	19,8	104	32	52	0,10	2	M3092P-2000AL-C0010	31205173
-------	----	------	-----	----	----	------	---	---------------------	----------

## Konfigurierbare Merkmale\*



**Schaftform:**  
Schaftform: HB



**Spezifikation:**  
M3092P-1200[**Schaftform**]L-C0010

**Beispiel:**  
M3092P-1200BL-C0010

Schaftform HB

Maßangaben in mm.

\* Konfigurierbare Merkmale gültig ab d1 = 3 mm.

Schnittwertempfehlung siehe Kapitelende.

Sonderausführungen und andere Beschichtungen auf Anfrage.

# OptiMill®-Uni-HPC-Slot

Eckfräser, lange Ausführung mit Hals  
M3293

**Ausführung:**

Fräserdurchmesser: 1,00 - 20,00 mm  
 Beschichtung: MF6/MF3  
 Schneidzahl: 3  
 Spiralwinkel: 42°-43°  
 Besonderheiten: Ungleichteilung

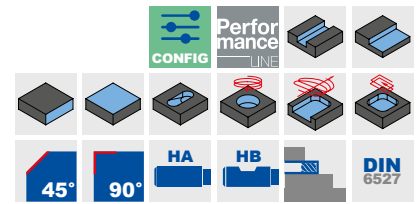
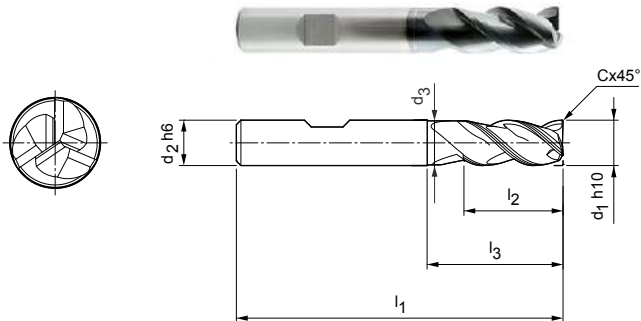

**Lagerhaltige Vorzugsbaureihe**

Baumaße							z	Spezifikation	Bestell-Nr.
d1 h10	d2 h6	d3	l1	l2	l3	Cx45°			
1,00	6	0,9	54	2,5	4	-	3	M3293-0100BN	30566813
1,50	6	1,4	54	4	6	-	3	M3293-0150BN	30486525
2,00	6	1,9	54	5	8	-	3	M3293-0200BN	30486524
2,50	6	2,4	54	6,5	10	-	3	M3293-0250BN	30566814
3,00	6	2,8	57	8	12,5	0,06	3	M3293-0300BY	30247171
4,00	6	3,8	57	11	15	0,08	3	M3293-0400BY	30247172
5,00	6	4,8	57	13	16	0,10	3	M3293-0500BY	30247173
6,00	6	5,8	57	13	20	0,12	3	M3293-0600BY	30247174
8,00	8	7,8	63	21	27	0,16	3	M3293-0800BY	30247175
10,00	10	9,8	72	22	30	0,20	3	M3293-1000BY	30247176
12,00	12	11,8	83	26	36	0,24	3	M3293-1200BY	30247177
16,00	16	15,8	92	36	44	0,32	3	M3293-1600BY	30247179
18,00	18	17,8	92	36	44	0,36	3	M3293-1800BY	30247180
20,00	20	19,8	104	41	55	0,40	3	M3293-2000BY	30247181

**Auf Anfrage erhältlich**

14,00	14	13,8	83	26	36	0,28	3	M3293-1400BY	30247178
-------	----	------	----	----	----	------	---	--------------	----------

**Konfigurierbare Merkmale**

**Schaftform:**  
Schaftform: HA

**Spezifikation:**  
M3293-1200[Schaftform]Y

Beispiel:  
M3293-1200AY

Schaftform HA

Maßangaben in mm.  
 Schnittwertempfehlung siehe Kapitelende.  
 Sonderausführungen und andere Beschichtungen auf Anfrage.

# OptiMill®-Uni-HPC-Pocket

Eckfräser, lange Ausführung mit Hals  
M3993

**Ausführung:**  
Fräserdurchmesser: 3,80 - 20,00 mm  
Beschichtung: MF2  
Schneidenzahl: 3  
Spiralwinkel: ~ 42°  
Besonderheiten: Stirngeometrie mit integrierter Bohrspitze

**Anwendung:**  
Ideal für schräges Eintauchen bis 45°, zum Helixfräsen und Stechen.

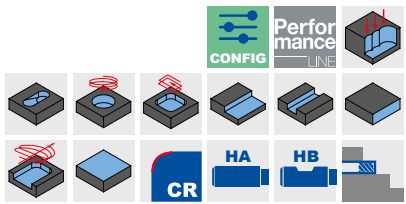
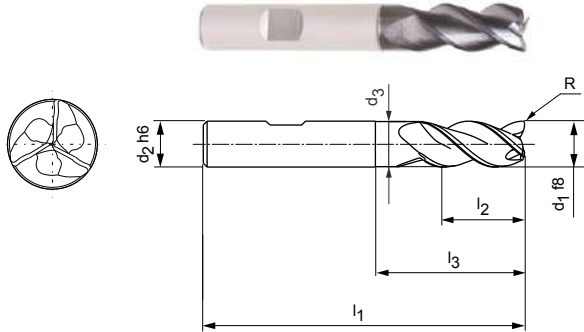

**Lagerhaltige Vorzugsbaureihe**

Baumaße							z	Spezifikation	Bestell-Nr.
d1 f8	d2 h6	d3	l1	l2	l3	R			
3,80	6	3,6	57	10	13	0,19	3	M3993-0380BL	31019870
4,00	6	3,8	57	11	13	0,2	3	M3993-0400BL	31019871
4,80	6	4,6	57	11	15,5	0,24	3	M3993-0480BL	31019872
5,00	6	4,8	57	13	15,5	0,25	3	M3993-0500BL	31019873
5,70	6	5,5	57	13	19	0,29	3	M3993-0570BL	30787991
6,00	6	5,8	57	13	19	0,3	3	M3993-0600BL	30787992
6,70	8	6,5	63	16	25	0,34	3	M3993-0670BL	30787993
7,00	8	6,8	63	16	25	0,35	3	M3993-0700BL	30787994
7,70	8	7,5	63	19	25	0,39	3	M3993-0770BL	30787995
8,00	8	7,8	63	19	25	0,4	3	M3993-0800BL	30787996
8,70	10	8,5	72	22	30	0,44	3	M3993-0870BL	30787997
9,00	10	8,8	72	22	30	0,45	3	M3993-0900BL	30787998
9,70	10	9,5	72	22	30	0,49	3	M3993-0970BL	30787999
10,00	10	9,8	72	22	30	0,5	3	M3993-1000BL	30788000
11,70	12	11,5	83	26	36	0,59	3	M3993-1170BL	30788001
12,00	12	11,8	83	26	36	0,6	3	M3993-1200BL	30788002
13,70	14	13,5	83	26	36	0,69	3	M3993-1370BL	30788003
14,00	14	13,8	83	26	36	0,7	3	M3993-1400BL	30788004
15,50	16	15,3	92	31	42	0,78	3	M3993-1550BL	30788005
16,00	16	15,8	92	31	42	0,8	3	M3993-1600BL	30788006
17,50	18	17,3	92	31	42	0,88	3	M3993-1750BL	30788007
18,00	18	17,8	92	31	42	0,9	3	M3993-1800BL	30788008
19,50	20	19,3	104	41	52	0,98	3	M3993-1950BL	30788009
20,00	20	19,8	104	41	52	1	3	M3993-2000BL	30788010

**Konfigurierbare Merkmale**

**Schaftform:**  
Schaftform: HA

**Spezifikation:**  
M3993-1200[Schaftform]L

**Beispiel:**  
M3993-1200AL

Schaftform HA

Maßangaben in mm.  
Schnittwertempfehlung siehe Kapitelende.  
Sonderausführungen und andere Beschichtungen auf Anfrage.

# OptiMill®-Uni-HPC-Pocket

Eckfräser, kurze Ausführung  
M3990

**Ausführung:**  
Fräserdurchmesser: 3,80 - 20,00 mm  
Beschichtung: MF2  
Schneidenzahl: 3  
Spiralwinkel: ~ 42°  
Besonderheiten: Stirrgeometrie mit integrierter Bohrspitze

**Anwendung:**  
Ideal für schräges Eintauchen bis 45°, zum Helixfräsen und Stechen.

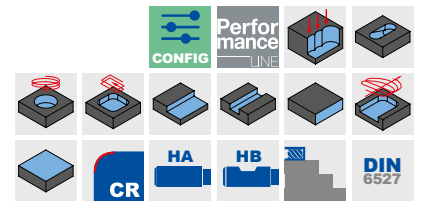
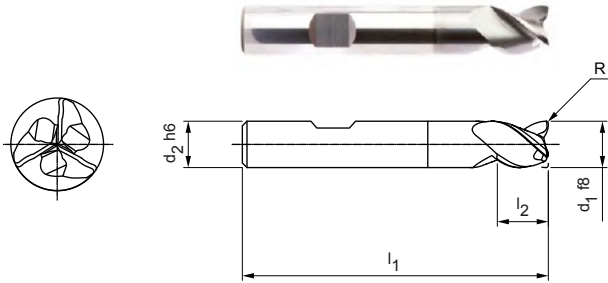

## Lagerhaltige Vorzugsbaureihe

Baumaße						z	Spezifikation	Bestell-Nr.
d1 f8	d2 h6	l1	l2	l5	R*			
3,80	6	54	5	10,5	0,12	3	M3990-0380BL	31019864
4,00	6	54	5	10,5	0,12	3	M3990-0400BL	31019865
4,80	6	54	6	12,5	0,2	3	M3990-0480BL	31019866
5,00	6	54	6	12,5	0,2	3	M3990-0500BL	31019868
5,70	6	54	7	14,5	0,2	3	M3990-0570BL	30866568
6,00	6	54	7	-	0,2	3	M3990-0600BL	30866569
6,70	8	58	8	16,5	0,2	3	M3990-0670BL	30866570
7,00	8	58	8	17	0,2	3	M3990-0700BL	30866571
7,70	8	58	9	18,5	0,2	3	M3990-0770BL	30866572
8,00	8	58	9	-	0,2	3	M3990-0800BL	30866573
8,70	10	66	10	20,5	0,32	3	M3990-0870BL	30866574
9,00	10	66	10	21	0,32	3	M3990-0900BL	30866575
9,70	10	66	11	22,5	0,32	3	M3990-0970BL	30866576
10,00	10	66	11	-	0,32	3	M3990-1000BL	30866577
11,70	12	73	12	24,5	0,32	3	M3990-1170BL	30866578
12,00	12	73	12	-	0,32	3	M3990-1200BL	30866579
13,70	14	75	14	26,5	0,32	3	M3990-1370BL	30866580
14,00	14	75	14	-	0,32	3	M3990-1400BL	30869103
15,50	16	82	16	30	0,32	3	M3990-1550BL	30866581
16,00	16	82	16	-	0,32	3	M3990-1600BL	30866582
17,50	18	84	18	32	0,32	3	M3990-1750BL	30866583
19,50	20	92	20	38	0,5	3	M3990-1950BL	30866585
20,00	20	92	20	-	0,5	3	M3990-2000BL	30866586

\* Eckenradius speziell zum Passfedernutfräsen nach DIN 6885.

## Auf Anfrage erhältlich

18,00	18	84	18	-	0,32	3	M3990-1800BL	30866584
-------	----	----	----	---	------	---	--------------	----------

## Konfigurierbare Merkmale



**Schaftform:**  
Schaftform: HA



**Spezifikation:**  
M3990-1200[Schaftform]L

**Beispiel:**  
M3990-1200AL

Schaftform HA

Maßangaben in mm.  
Schnittwertempfehlung siehe Kapitelende.  
Sonderausführungen und andere Beschichtungen auf Anfrage.

# OptiMill®-Uni-HPC-Pocket

Eckfräser, überlange Ausführung mit Hals  
M3991

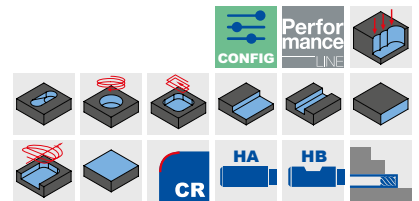
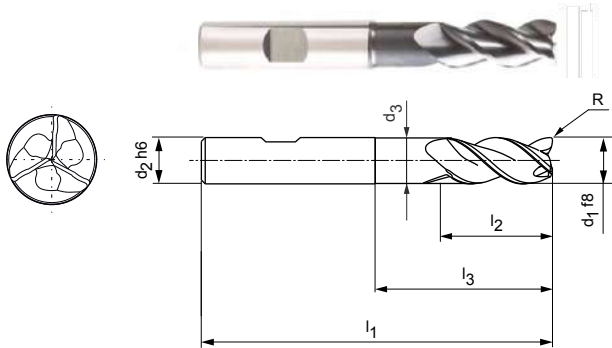

**Ausführung:**  
Fräserdurchmesser: 5,00 - 20,00 mm  
Beschichtung: MF2  
Schneidenzahl: 3  
Spiralwinkel: ~ 42°  
Besonderheiten: Stirngeometrie mit integrierter Bohrspitze

**Anwendung:**  
Ideal für schräges Eintauchen bis 45°, zum Helixfräsen und Stechen.

## Lagerhaltige Vorzugsbaureihe

Baumaße							z	Spezifikation	Bestell-Nr.
d1 f8	d2 h6	d3	l1	l2	l3	R			
5,00	6	4,8	62	13	24	0,25	3	M3991-0500BL	31019890
5,70	6	5,5	62	13	24	0,29	3	M3991-0570BL	30787924
6,00	6	5,8	62	13	24	0,3	3	M3991-0600BL	30787927
6,70	8	6,4	68	16	30	0,34	3	M3991-0670BL	30787928
7,00	8	6,7	68	16	30	0,35	3	M3991-0700BL	30787929
7,70	8	7,4	68	21	30	0,39	3	M3991-0770BL	30787930
8,00	8	7,7	68	21	30	0,4	3	M3991-0800BL	30787931
8,70	10	8,4	80	22	38	0,44	3	M3991-0870BL	30787932
9,00	10	8,7	80	22	38	0,45	3	M3991-0900BL	30787933
9,70	10	9,4	80	22	38	0,49	3	M3991-0970BL	30787934
10,00	10	9,7	80	22	38	0,5	3	M3991-1000BL	30787935
11,70	12	11,3	93	26	46	0,59	3	M3991-1170BL	30787936
12,00	12	11,6	93	26	46	0,6	3	M3991-1200BL	30787937
13,70	14	13,3	99	26	52	0,69	3	M3991-1370BL	30787938
14,00	14	13,6	99	26	52	0,7	3	M3991-1400BL	30787939
15,50	16	15	108	36	58	0,78	3	M3991-1550BL	30787940
16,00	16	15,5	108	36	58	0,8	3	M3991-1600BL	30787941
17,50	18	17	117	36	67	0,88	3	M3991-1750BL	30787942
18,00	18	17,5	117	36	67	0,9	3	M3991-1800BL	30787943
19,50	20	19	126	41	74	0,98	3	M3991-1950BL	30787944
20,00	20	19,5	126	41	74	1	3	M3991-2000BL	30787945

## Konfigurierbare Merkmale

**Schaftform:**  
Schaftform: HA

**Spezifikation:**  
M3991-1200[Schaftform]L

Beispiel:  
M3991-1200AL

Schaftform HA

Maßangaben in mm.  
Schnittwertempfehlung siehe Kapitelende.  
Sonderausführungen und andere Beschichtungen auf Anfrage.

# OptiMill®-Uni-HPC-Silent

Eckfräser, lange Ausführung mit Hals  
M3095

**Ausführung:**

Fräserdurchmesser: 6,00 - 25,00 mm  
 Beschichtung: MF2  
 Schneidenzahl: 5  
 Spiralwinkel: 41°-42°  
 Besonderheiten: Ungleichteilung

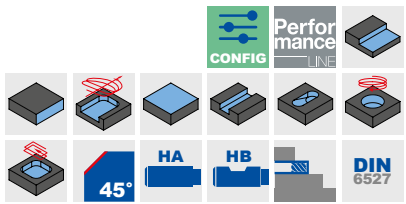
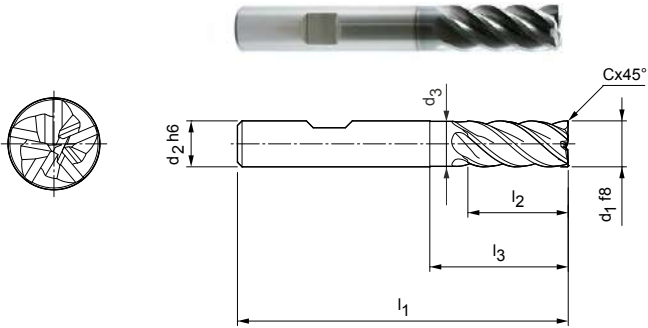

**Lagerhaltige Vorzugsbaureihe**

Baumaße							z	Spezifikation	Bestell-Nr.
d1 f8	d2 h6	d3	l1	l2	l3	Cx45°			
6,00	6	5,8	57	13	19	0,12	5	M3095-0600BL	30479500
8,00	8	7,8	63	19	25	0,16	5	M3095-0800BL	30482153
10,00	10	9,8	72	22	30	0,20	5	M3095-1000BL	30482154
12,00	12	11,8	83	26	36	0,24	5	M3095-1200BL	30482155
16,00	16	15,8	92	32	42	0,32	5	M3095-1600BL	30482156
20,00	20	19,8	104	41	52	0,40	5	M3095-2000BL	30482157
25,00	25	24,5	125	50	65	0,50	5	M3095-2500BL	30482158

**Auf Anfrage erhältlich**

14,00	14	13,8	83	26	36	0,28	5	M3095-1400BL	30491448
18,00	18	17,8	92	32	42	0,36	5	M3095-1800BL	30491450

**Konfigurierbare Merkmale**



**Schaftform:**  
Schaftform: HA



**Spezifikation:**  
M3095-1200[Schaftform]L

**Beispiel:**  
M3095-1200AL

Schaftform HA

Maßangaben in mm.  
 Schnittwertempfehlung siehe Kapitelende.  
 Sonderausführungen und andere Beschichtungen auf Anfrage.



# ECU-Mill-Uni-LV

Eckfräser, kurze Ausführung  
M4090

**Ausführung:**  
Fräserdurchmesser: 3,00 - 20,00 mm  
Beschichtung: MF20  
Schneidenzahl: 4  
Spiralwinkel: 36°/38,5°  
Besonderheiten: Ungleichteilung

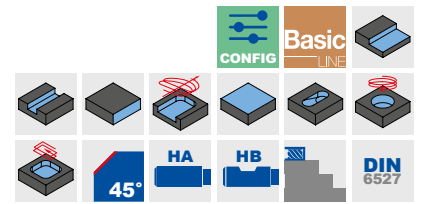
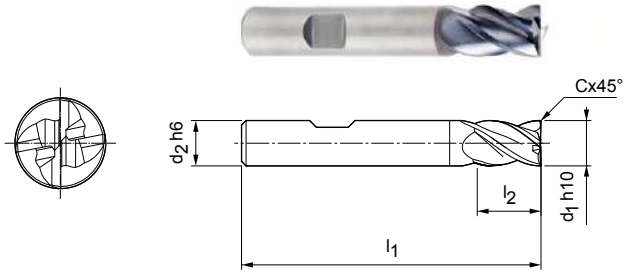

## Lagerhaltige Vorzugsbaureihe

Baumaße					z	Spezifikation	Bestell-Nr.
d <sub>1</sub> h10	d <sub>2</sub> h6	l <sub>1</sub>	l <sub>2</sub>	Cx45°			
3,00	6	50	6	0,06	4	M4090-0300BD	30656917
4,00	6	54	8	0,08	4	M4090-0400BD	30656918
5,00	6	54	9	0,10	4	M4090-0500BD	30656919
6,00	6	54	10	0,12	4	M4090-0600BD	30656920
8,00	8	58	12	0,16	4	M4090-0800BD	30656921
10,00	10	66	14	0,20	4	M4090-1000BD	30656922
12,00	12	73	16	0,24	4	M4090-1200BD	30656923
16,00	16	82	22	0,32	4	M4090-1600BD	30656925
20,00	20	92	26	0,40	4	M4090-2000BD	30656927

## Auf Anfrage erhältlich

14,00	14	73	16	0,28	4	M4090-1400BD	30656924
18,00	18	82	22	0,36	4	M4090-1800BD	30656926

## Konfigurierbare Merkmale



**Schaftform:**  
Schaftform: HA



**Spezifikation:**  
M4090-1200[Schaftform]D

Beispiel:  
M4090-1200AD

Schaftform HA

Maßangaben in mm.  
Schnittwertempfehlung siehe Kapitelende.  
Sonderausführungen und andere Beschichtungen auf Anfrage.

# ECU-Mill-Uni-LV

Eckfräser, lange Ausführung mit Hals  
M4094

**Ausführung:**

Fräserdurchmesser: 3,00 - 20,00 mm  
 Beschichtung: MF20  
 Schneidenzahl: 4  
 Spiralwinkel: 36°/38,5°  
 Besonderheiten: Ungleichteilung

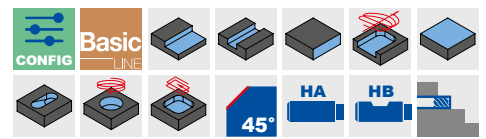
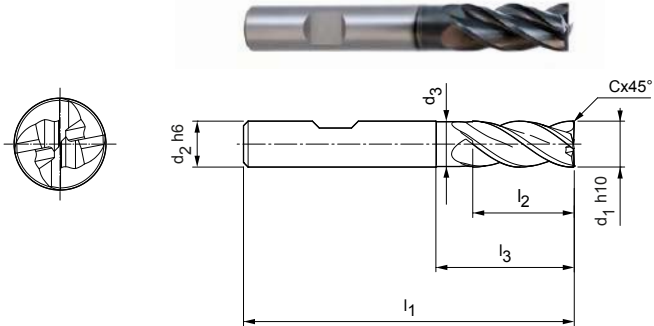

**Lagerhaltige Vorzugsbaureihe**

Baumaße							z	Spezifikation	Bestell-Nr.
d1 h10	d2 h6	d3	l1	l2	l3	Cx45°			
3,00*	6	–	57	8	–	0,06	4	M4094-0300BD	30656905
4,00*	6	–	57	11	–	0,08	4	M4094-0400BD	30656906
5,00*	6	–	57	13	–	0,10	4	M4094-0500BD	30656907
6,00	6	5,8	57	13	20	0,12	4	M4094-0600BD	30656908
8,00	8	7,8	63	21	25	0,16	4	M4094-0800BD	30656909
10,00	10	9,8	72	22	30	0,20	4	M4094-1000BD	30656910
12,00	12	11,8	83	26	36	0,24	4	M4094-1200BD	30656911
14,00	14	13,8	83	26	36	0,28	4	M4094-1400BD	30656912
16,00	16	15,8	92	36	42	0,32	4	M4094-1600BD	30656913
20,00	20	19,8	104	41	53	0,40	4	M4094-2000BD	30656915

**Auf Anfrage erhältlich**

18,00	18	17,8	92	36	42	0,36	4	M4094-1800BD	30656914
-------	----	------	----	----	----	------	---	--------------	----------

**Konfigurierbare Merkmale**



**Schaftform:**  
Schaftform: HA



**Spezifikation:**  
M4094-1200[**Schaftform**]D

Beispiel:  
M4094-1200AD

Schaftform HA

Maßangaben in mm.

\* Ausführung ohne Hals.

Schnittwertempfehlung siehe Kapitelende.

Sonderausführungen und andere Beschichtungen auf Anfrage.

# OptiMill®-Hardened

Eckfräser, lange Ausführung mit Hals  
M3274

**Ausführung:**

Fräserdurchmesser: 4,00 - 20,00 mm  
Beschichtung: MFT  
Schneidenzahl: 4  
Spiralwinkel: 42°

**Anwendung:**

Zum Schrumpfen von Bauteilen mit einer Härte ab 45 HRC.

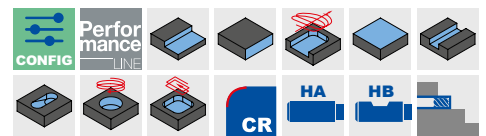
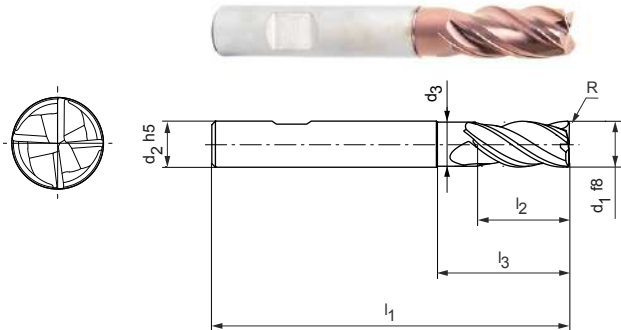

**Lagerhaltige Vorzugsbaureihe**

Baumaße							z	Spezifikation	Bestell-Nr.
d1 f8	d2 h5	d3	l1	l2	l3	R			
4,00	6	–	57	11	–	0,5	4	M3274-0400B09-R0050	31154802
4,00	6	–	57	11	–	1	4	M3274-0400B09-R0100	31154803
6,00	6	5,8	57	13	20	0,5	4	M3274-0600B09-R0050	31154806
6,00	6	5,8	57	13	20	1	4	M3274-0600B09-R0100	31154807
6,00	6	5,8	57	13	20	2	4	M3274-0600B09-R0200	31154809
8,00	8	7,8	63	21	25	0,5	4	M3274-0800B09-R0050	31154810
8,00	8	7,8	63	21	25	1	4	M3274-0800B09-R0100	31154811
8,00	8	7,8	63	21	25	2	4	M3274-0800B09-R0200	31154814
10,00	10	9,8	72	22	30	0,5	4	M3274-1000B09-R0050	31154817
10,00	10	9,8	72	22	30	1	4	M3274-1000B09-R0100	31154818
10,00	10	9,8	72	22	30	2	4	M3274-1000B09-R0200	31154820
12,00	12	11,8	83	26	36	0,5	4	M3274-1200B09-R0050	31154823
12,00	12	11,8	83	26	36	1	4	M3274-1200B09-R0100	31154824
12,00	12	11,8	83	26	36	2	4	M3274-1200B09-R0200	31154826
16,00	16	15,8	92	36	42	0,5	4	M3274-1600B09-R0050	31154830
16,00	16	15,8	92	36	42	1	4	M3274-1600B09-R0100	31154831
16,00	16	15,8	92	36	42	2	4	M3274-1600B09-R0200	31154832
20,00	20	19,8	104	41	55	1	4	M3274-2000B09-R0100	31154836
20,00	20	19,8	104	41	55	2	4	M3274-2000B09-R0200	31154837

**Konfigurierbare Merkmale**



**Schaftform:**  
Schaftform: HA



**Spezifikation:**  
M3274-1200[**Schaftform**]09-R0050

**Beispiel:**  
M3274-1200**A**09-R0050

Schaftform HA

Maßangaben in mm.  
Schnittwertempfehlung siehe Kapitelende.  
Sonderausführungen und andere Beschichtungen auf Anfrage.

# OptiMill®-Hardened

Eckfräser, überlange Ausführung mit Hals  
M3271

**Ausführung:**

Fräserdurchmesser: 4,00 - 20,00 mm  
Beschichtung: MFT  
Schneidenzahl: 4  
Spiralwinkel: 42°

**Anwendung:**

Zum Schruppen von Bauteilen mit einer Härte ab 45 HRC.

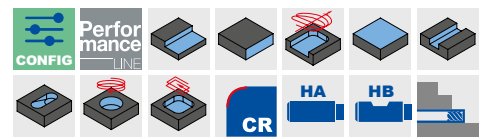
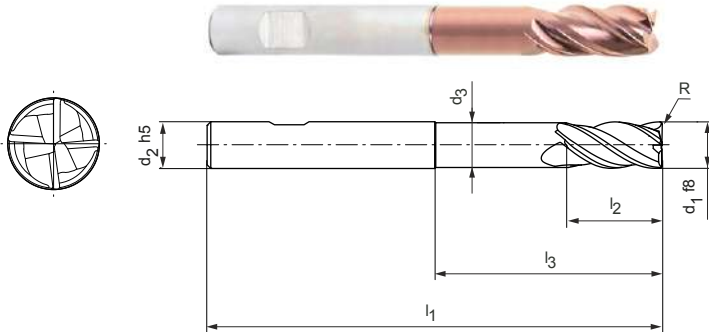

**Lagerhaltige Vorzugsbaureihe**

Baumaße							z	Spezifikation	Bestell-Nr.
d1 f8	d2 h5	d3	l1	l2	l3	R			
4,00	6	3,8	62	11	22	0,5	4	M3271-0400B09-R0050	31154840
4,00	6	3,8	62	11	22	1	4	M3271-0400B09-R0100	31154841
6,00	6	5,8	62	13	25	0,5	4	M3271-0600B09-R0050	31154844
6,00	6	5,8	62	13	25	1	4	M3271-0600B09-R0100	31154845
6,00	6	5,8	62	13	25	2	4	M3271-0600B09-R0200	31154846
8,00	8	7,7	68	21	30	1	4	M3271-0800B09-R0100	31154847
8,00	8	7,7	68	21	30	2	4	M3271-0800B09-R0200	31154848
10,00	10	9,7	80	22	38	0,5	4	M3271-1000B09-R0050	31154849
10,00	10	9,7	80	22	38	1	4	M3271-1000B09-R0100	31154850
10,00	10	9,7	80	22	38	2	4	M3271-1000B09-R0200	31154852
12,00	12	11,6	93	26	46	0,5	4	M3271-1200B09-R0050	31154854
12,00	12	11,6	93	26	46	1	4	M3271-1200B09-R0100	31154855
12,00	12	11,6	93	26	46	2	4	M3271-1200B09-R0200	31154857
16,00	16	15,5	108	36	58	0,5	4	M3271-1600B09-R0050	31154859
16,00	16	15,5	108	36	58	1	4	M3271-1600B09-R0100	31154860
16,00	16	15,5	108	36	58	2	4	M3271-1600B09-R0200	31154861
20,00	20	19,5	126	41	74	1	4	M3271-2000B09-R0100	31154863
20,00	20	19,5	126	41	74	2	4	M3271-2000B09-R0200	31154864

**Konfigurierbare Merkmale**



**Schaftform:**  
Schaftform: HA



**Spezifikation:**  
M3271-1200[Schaftform]09-R0050

**Beispiel:**  
M3271-1200A09-R0050

Schaftform HA

Maßangaben in mm.  
Schnittwertempfehlung siehe Kapitelende.  
Sonderausführungen und andere Beschichtungen auf Anfrage.

# OptiMill®-Inox-HPC

Eckfräser, lange Ausführung mit Hals  
M3644

**Ausführung:**  
Fräserdurchmesser: 3,00 - 20,00 mm  
Beschichtung: MF20  
Schneidenzahl: 4  
Spiralwinkel: 38°  
Besonderheiten: Ungleichteilung

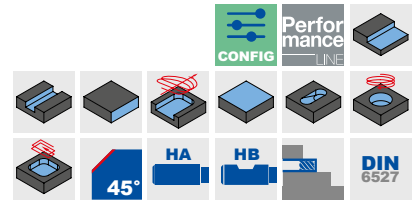
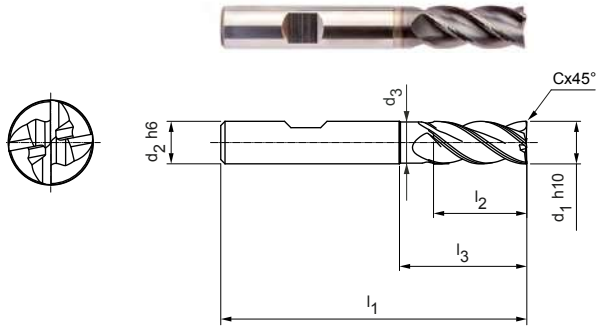

## Lagerhaltige Vorzugsbaureihe

Baumaße							z	Spezifikation	Bestell-Nr.
d <sub>1</sub> h10	d <sub>2</sub> h6	d <sub>3</sub>	l <sub>1</sub>	l <sub>2</sub>	l <sub>3</sub>	Cx45°			
3,00	6	-	57	8	-	0,06	4	M3644-0300BD-C0006	31319438
4,00	6	-	57	11	-	0,08	4	M3644-0400BD-C0008	31319439
5,00	6	-	57	13	-	0,10	4	M3644-0500BD-C0010	31319450
6,00	6	5,8	57	13	19	0,12	4	M3644-0600BD-C0012	31319452
8,00	8	7,8	63	19	25	0,16	4	M3644-0800BD-C0016	31319453
10,00	10	9,8	72	22	30	0,20	4	M3644-1000BD-C0020	31319457
12,00	12	11,8	83	26	36	0,24	4	M3644-1200BD-C0024	31319459
16,00	16	15,8	92	32	42	0,32	4	M3644-1600BD-C0032	31319461
20,00	20	19,8	104	38	52	0,40	4	M3644-2000BD-C0040	31319463

## Auf Anfrage erhältlich

14,00	14	13,8	83	26	36	0,28	4	M3644-1400BD-C0028	31319460
18,00	18	17,8	92	32	42	0,36	4	M3644-1800BD-C0036	31319462

## Konfigurierbare Merkmale



**Schaftform:**  
Schaftform: HA



**Spezifikation:**  
M3644-1200[Schaftform]D-C0024

**Beispiel:**  
M3644-1200AD-C0024

Schaftform HA

Maßangaben in mm.  
Schnittwertempfehlung siehe Kapitelende.  
Sonderausführungen und andere Beschichtungen auf Anfrage.

# OptiMill®-Titan-HPC

Eckfräser, lange Ausführung mit Hals  
M3614

**Ausführung:**

Fräserdurchmesser: 6,00 - 25,00 mm  
 Beschichtung: MF18  
 Schneidenzahl: 4  
 Spiralwinkel: 43°  
 Besonderheit: Ungleichteilung

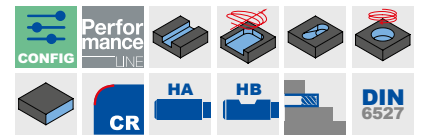
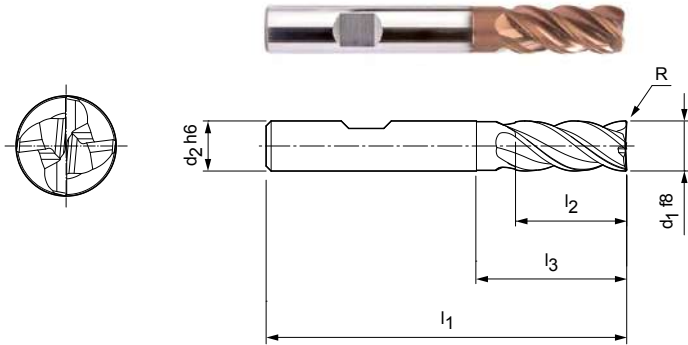

**Lagerhaltige Vorzugsbaureihe**

Baumaße							Spezifikation	Bestell-Nr.
d1 f8	d2 h6	l1	l2	d3	l3	R		
6,00	6	57	13	5,8	20	0,50	M3614-0600B13-R0050	31304508
6,00	6	57	13	5,8	20	1,00	M3614-0600B13-R0100	31304539
8,00	8	63	21	7,8	25	0,50	M3614-0800B13-R0050	31304540
8,00	8	63	21	7,8	25	1,00	M3614-0800B13-R0100	31304542
10,00	10	72	22	9,8	30	0,50	M3614-1000B13-R0050	31304548
10,00	10	72	22	9,8	30	1,00	M3614-1000B13-R0100	31304550
12,00	12	83	26	11,8	36	0,50	M3614-1200B13-R0050	31304556
12,00	12	83	26	11,8	36	1,00	M3614-1200B13-R0100	31304559
16,00	16	92	36	15,8	42	1,00	M3614-1600B13-R0100	31304577
16,00	16	92	36	15,8	42	2,00	M3614-1600B13-R0200	31304579
20,00	20	104	41	19,7	55	1,00	M3614-2000B13-R0100	31304587
20,00	20	104	41	19,7	55	2,00	M3614-2000B13-R0200	31304590
25,00	25	136	50	24,7	65	2,00	M3614-2500B13-R0200	31304593

**Auf Anfrage erhältlich**

8,00	8	63	21	7,8	25	2,00	M3614-0800B13-R0200	31304543
10,00	10	72	22	9,8	30	2,00	M3614-1000B13-R0200	31304553
12,00	12	83	26	11,8	36	2,00	M3614-1200B13-R0200	31304572
12,00	12	83	26	11,8	36	3,00	M3614-1200B13-R0300	31304574
16,00	16	92	36	15,8	42	3,00	M3614-1600B13-R0300	31304581
16,00	16	92	36	15,8	42	4,00	M3614-1600B13-R0400	31304584
20,00	20	104	41	19,7	55	3,00	M3614-2000B13-R0300	31304591
20,00	20	104	41	19,7	55	4,00	M3614-2000B13-R0400	31304592
25,00	25	136	50	24,7	65	3,00	M3614-2500B13-R0300	31304594
25,00	25	136	50	24,7	65	4,00	M3614-2500B13-R0400	31304595

**Konfigurierbare Merkmale**



**Schaftform:**  
Schaftform: HA



**Spezifikation:**  
M3614-1200[Schaftform]13-R0050

**Beispiel:**

M3614-1200A13-R0050

Schaftform HA

Maßangaben in mm.  
 Schnittwertempfehlung siehe Kapitelende.  
 Sonderausführungen und andere Beschichtungen auf Anfrage.

# OptiMill®-Alu-HPC

Eckfräser, lange Ausführung mit Hals  
M3493

**Ausführung:**

Fräserdurchmesser: 3,00 - 20,00 mm  
 Beschichtung: Unbeschichtet  
 Schneidenzahl: 3  
 Spiralwinkel: 42°-43°  
 Besonderheiten: Ungleichteilung, Nuten poliert

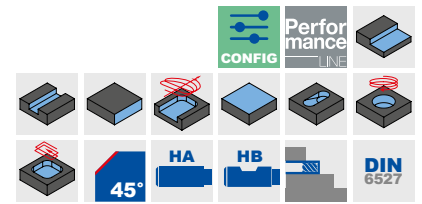
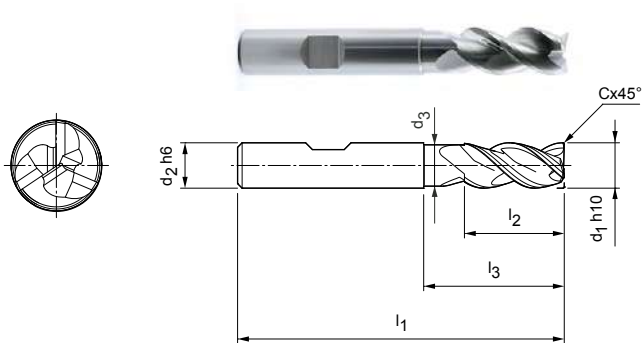

**Lagerhaltige Vorzugsbaureihe**

Baumaße							z	Spezifikation	Bestell-Nr.
d1 h10	d2 h6	d3	l1	l2	l3	Cx45°			
3,00*	6	-	57	7	-	0,06	3	M3493-0300BU	30248238
4,00*	6	-	57	8	-	0,08	3	M3493-0400BU	30248241
5,00*	6	-	57	10	-	0,10	3	M3493-0500BU	30248242
6,00	6	5,5	57	10	18	0,12	3	M3493-0600BU	30248243
8,00	8	7,5	63	16	25	0,16	3	M3493-0800BU	30248244
10,00	10	9	72	19	30	0,20	3	M3493-1000BU	30248245
12,00	12	11	83	22	36	0,24	3	M3493-1200BU	30248246
16,00	16	15	92	26	42	0,32	3	M3493-1600BU	30248247
20,00	20	19	104	32	52	0,40	3	M3493-2000BU	30248248

**Auf Anfrage erhältlich**

14,00	14	13	83	22	36	0,28	3	M3493-1400BU	30374845
-------	----	----	----	----	----	------	---	--------------	----------

**Konfigurierbare Merkmale**



**Schaftform:**  
Schaftform: HA



**Spezifikation:**  
M3493-1200[Schaftform]U

Beispiel:  
M3493-1200AU

Schaftform HA

Maßangaben in mm.  
 \* Ausführung ohne Hals.  
 Schnittwertempfehlung siehe Kapitelende.  
 Sonderausführungen und andere Beschichtungen auf Anfrage.

# OptiMill®-Alu-HPC-Pocket

Eckfräser, lange Ausführung mit Hals  
M3413

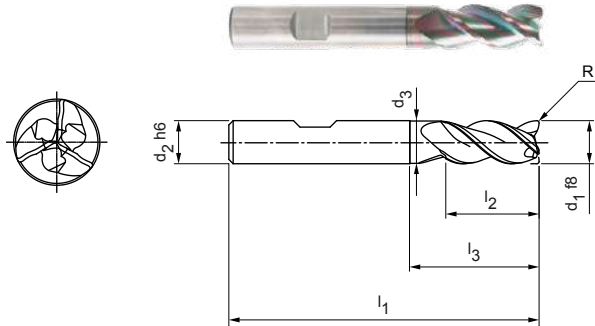

**Ausführung:**  
Fräserdurchmesser: 5,00 - 20,00 mm  
Beschichtung: MF8  
Schneidenzahl: 3  
Spiralwinkel: 42°  
Besonderheiten: Stirngeometrie mit integrierter Bohrspitze

**Anwendung:**  
Ideal für schräges Eintauchen bis 45°, zum Helixfräsen und Stechen.

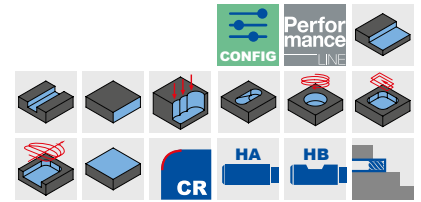

## Lagerhaltige Vorzugsbaureihe

Baumaße							z	Spezifikation	Bestell-Nr.
d1 f8	d2 h6	d3	l1	l2	l3	R			
5,00	6	4,8	57	13	–	0,2	3	M3413-0500B02	31050392
6,00	6	5,8	57	13	19	0,2	3	M3413-0600B02	31050394
8,00	8	7,8	63	19	25	0,2	3	M3413-0800B02	31050398
10,00	10	9,8	72	22	30	0,32	3	M3413-1000B02	31050402
12,00	12	11,8	83	26	36	0,32	3	M3413-1200B02	31050404
14,00	14	13,8	83	26	36	0,32	3	M3413-1400B02	31050406
16,00	16	15,8	92	31	42	0,32	3	M3413-1600B02	31050408
20,00	20	19,8	104	41	52	0,5	3	M3413-2000B02	31050412

Untermaßfräser auf Anfrage erhältlich.

## Konfigurierbare Merkmale



**Schaftform:**  
Schaftform: HA



**Spezifikation:**  
M3413-1200[Schaftform]02

Beispiel:  
M3413-1200A02

Schaftform HA

Maßangaben in mm.  
Schnittwertempfehlung siehe Kapitelende.  
Sonderausführungen und andere Beschichtungen auf Anfrage.



# OptiMill®-Alu-HPC-Pocket

Eckfräser, Ausführung 3xD mit Hals, mit Spanteiler  
M3414

**Ausführung:**  
Fräserdurchmesser: 5,00 - 20,00 mm  
Beschichtung: MF8  
Schneidenzahl: 4  
Spiralwinkel: 36°  
Besonderheiten: Stirrgeometrie mit integrierter Bohrspitze

**Anwendung:**  
Ideal für schräges Eintauchen bis 45°, zum Helixfräsen und Stechen.

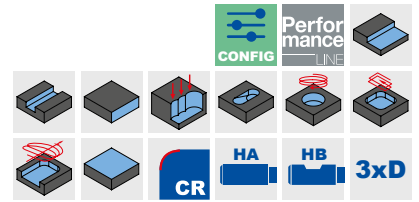
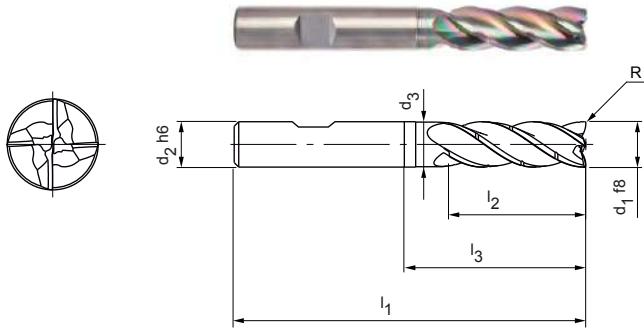

**Lagerhaltige Vorzugsbaureihe**

Baumaße							z	Spezifikation	Bestell-Nr.
d1 f8	d2 h6	d3	l1	l2	l3	R			
5,00	6	4,8	62	17	-	0,20	4	M3414-3D-0500B02-R0020	31175143
6,00	6	5,8	62	18	25	0,20	4	M3414-3D-0600B02-R0020	31175144
8,00	8	7,7	68	24	30	0,20	4	M3414-3D-0800B02-R0020	31175145
10,00	10	9,7	80	30	35	0,32	4	M3414-3D-1000B02-R0032	31175146
12,00	12	11,6	93	36	45	0,32	4	M3414-3D-1200B02-R0032	31175147
14,00	14	13,6	99	42	50	0,32	4	M3414-3D-1400B02-R0032	31175148
16,00	16	15,5	108	48	56	0,32	4	M3414-3D-1600B02-R0032	31175149
20,00	20	19,5	126	60	70	0,50	4	M3414-3D-2000B02-R0050	31175161

**Auf Anfrage erhältlich**

18,00	18	17,5	117	54	67	0,32	4	M3414-3D-1800B02-R0032	31175160
-------	----	------	-----	----	----	------	---	------------------------	----------

**Konfigurierbare Merkmale**



**Schaftform:**  
Schaftform: HA



**Spezifikation:**  
M3414-3D-1200[**Schaftform**]02-R0032

**Beispiel:**  
M3414-3D-1200A02-R0032

Schaftform HA

Maßangaben in mm.  
Schnittwertempfehlung siehe Kapitelende.  
Sonderausführungen und andere Beschichtungen auf Anfrage.

# OptiMill®-SPM

Eckfräser mit Innenkühlung  
M3593 | M3591

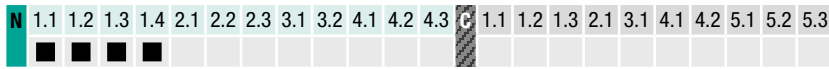
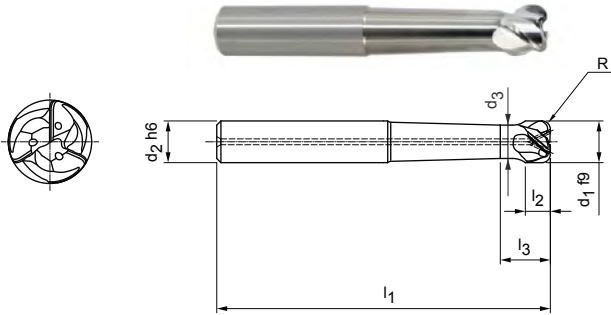

**Ausführung:**  
Fräserdurchmesser: 12,00 - 32,00 mm  
Beschichtung: Unbeschichtet  
Schneidenzahl: 3  
Spiralwinkel: 43°

**Anwendung:**  
Für die Bearbeitung von Strukturbauteilen aus Aluminium.

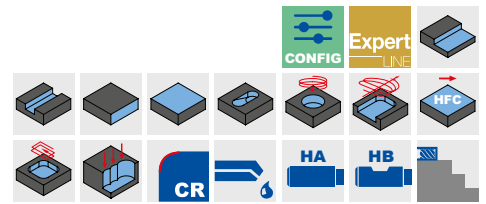

### Kurze Ausführung, M3593 | Lagerhaltige Vorzugsbaureihe

Baumaße							z	Spezifikation	Bestell-Nr.
d <sub>1</sub> f9	d <sub>2</sub> h6	d <sub>3</sub>	l <sub>1</sub>	l <sub>2</sub>	l <sub>3</sub>	R			
32,00	32	27	125	26,3	40,9	4	3	M3593-3200AU-R0400	30612316

### Kurze Ausführung, M3593 | Auf Anfrage erhältlich

16,00	16	12,8	81	12,8	28	3	3	M3593-1600AU-R0300	30612312
20,00	20	16	90	16	35	3	3	M3593-2000AU-R0300	30612314

### Lange Ausführung, M3591 | Lagerhaltige Vorzugsbaureihe

Baumaße							z	Spezifikation	Bestell-Nr.
d <sub>1</sub> f9	d <sub>2</sub> h6	d <sub>3</sub>	l <sub>1</sub>	l <sub>2</sub>	l <sub>3</sub>	R			
12,00	12	9,6	90	10,3	19,4	2	3	M3591-1200AU-R0200	30612320
16,00	16	12,8	105	13,5	23,8	3	3	M3591-1600AU-R0300	30612323
20,00	20	16	120	16,7	28,2	3	3	M3591-2000AU-R0300	30612325
25,00	25	20	145	20,7	33,7	4	3	M3591-2500AU-R0400	30612326
32,00	32	27	173	26,3	40,2	4	3	M3591-3200AU-R0400	30612327

### Lange Ausführung, M3591 | Auf Anfrage erhältlich

14,00	16	11,2	99	11,2	45,5	3	3	M3591-1400AU-R0300	30612321
-------	----	------	----	------	------	---	---	--------------------	----------

### Konfigurierbare Merkmale



**Schaftform:**  
Schaftform: HB



**Spezifikation:**  
M3591-1200[**Schaftform**]U-R0200

**Beispiel:**  
M3591-1200BU-R0200

\_\_\_\_\_ Schaftform HB

Maßangaben in mm.  
Schnittwertempfehlung siehe Kapitelende.  
Sonderausführungen und andere Beschichtungen auf Anfrage.

# OptiMill®-Mono-Alu

Eckfräser, Ausführung mit ziehender/schiebender Schneide  
MN7MA1A

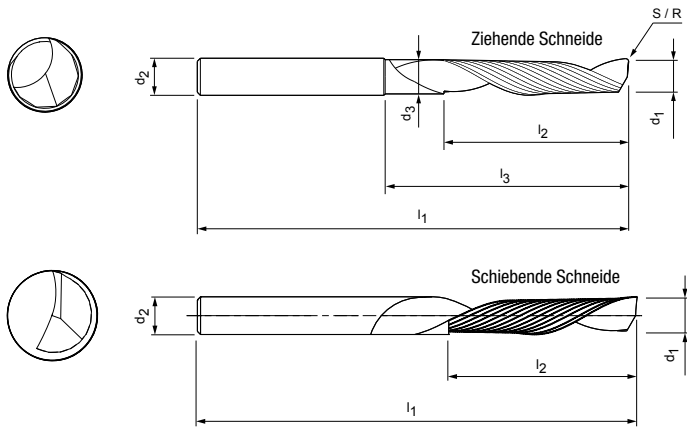

**Ausführung:**

Fräserdurchmesser:  
Beschichtung:  
Schneidenzahl:  
Spiralwinkel:  
Besonderheiten:

2,00 - 10,00 mm  
Unbeschichtet  
1  
30°  
großer Spanraum für ungehinderten Spanablauf

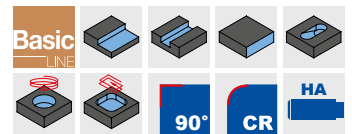
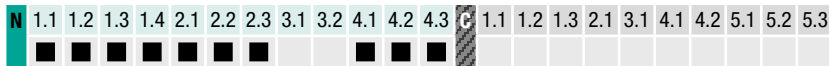

**Lagerhaltige Vorzugsbaureihe**

Baumaße							z	Spezifikation	Bestell-Nr.
d <sub>1</sub>	d <sub>2</sub>	d <sub>3</sub>	l <sub>1</sub>	l <sub>2</sub>	l <sub>3</sub>	R			
2,00	3	-	38	5	-	-	1	MN7MA1A-0200	30253284
3,00	3	-	38	8	-	-	1	MN7MA1A-0300	30218904
3,00	4	-	38	8	-	-	1	MN7MA1B-0300	30218905
4,00	4	-	40	12	-	-	1	MN7MA1A-0400	30218919
4,00	4	-	70	30	-	-	1	MN7MA1B-0400	30218920
4,00	6	-	50	10	-	-	1	MN7MA1C-0400	30218921
4,00	6	-	50	10	-	-	1	MN7MA2B-0400	30230601
5,00	5	-	60	15	-	-	1	MN7MA1A-0500	30218923
5,00	6	-	50	12	-	-	1	MN7MA1C-0500	30218925
6,00	6	-	50	12	-	-	1	MN7MA1E-0600	30218930
6,00	6	-	60	15	-	-	1	MN7MA2A-0600	30230611
6,00	6	-	60	20	-	-	1	MN7MA1A-0600	30218926
6,00	6	-	70	15	-	-	1	MN7MA1D-0600	30218929
6,00	6	-	70	30	-	-	1	MN7MA1B-0600	30218927
6,00	6	-	80	38	-	-	1	MN7MA1C-0600	30218928
6,00	8	5,6	80	20	35	1,50	1	MN7MA3A-0600	30237646
8,00	8	-	60	22	-	-	1	MN7MA1A-0800	30218932
8,00	8	-	80	38	-	-	1	MN7MA1B-0800	30218933
10,00	10	-	60	25	-	-	1	MN7MA1B-1000	30218935
10,00	10	-	75	30	-	-	1	MN7MA1A-1000	30218934

**Beispiel:**  
MN7MA[Schneide]B-1000

1 = ziehende Schneide  
2 = schiebende Schneide

Maßangaben in mm.  
Schnittwertempfehlung siehe Kapitelende.  
Sonderausführungen und andere Beschichtungen auf Anfrage.

# OptiMill®-Composite-Speed-Plus

Eckfräser, Ausführung mit ziehender Schneide  
M7248P

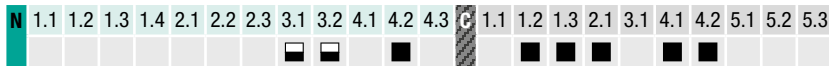
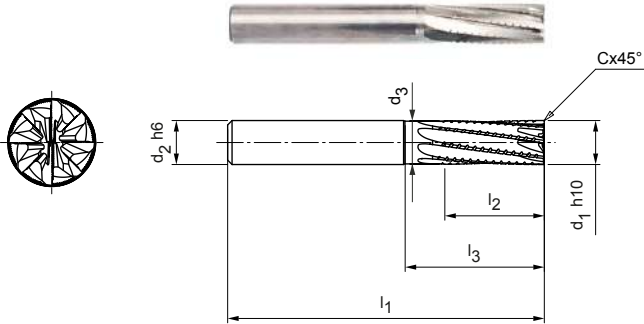

**Ausführung:**  
Fräserdurchmesser: 4,00 - 20,00 mm  
Beschichtung: Unbeschichtet  
Schneidenzahl: 8  
Spiralwinkel: 8°  
Besonderheiten: Ohne Beschichtung, extrem scharfe Schneidkanten

**Anwendung:**  
Schrupp- und Schlichtbearbeitung von CFK in einem Arbeitsgang. Ziehende Schneide für eine bessere Abfuhr der Späne/Stäube (z. B. beim Fräsen von Taschen und Nuten). Besonders geeignet für schwer zerspanbare Decklagen (z. B. UD oder Copper Mesh) zur Vermeidung von Delamination an der Bauteilunterkante.

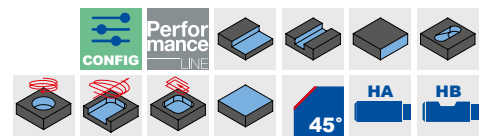

## Lagerhaltige Vorzugsbaureihe

Baumaße							z	Spezifikation	Bestell-Nr.
d1 h10	d2 h6	d3	l1	l2	l3	Cx45°			
4,00	6	3,90	57	11	–	0,08	8	M7248P-0400AU-C0008	31237383
5,00	6	4,90	57	13	–	0,10	8	M7248P-0500AU-C0010	31237384
6,00	6	5,80	57	13	19	0,12	8	M7248P-0600AU-C0012	31237385
6,00	6	5,80	65	21	27	0,12	8	M7248P-0600AU-C0012	31237386
8,00	8	7,80	63	19	25	0,16	8	M7248P-0800AU-C0016	31237387
8,00	8	7,80	70	22	32	0,16	8	M7248P-0800AU-C0016	31237388
10,00	10	9,70	72	22	30	0,20	8	M7248P-1000AU-C0020	31237389
12,00	12	11,60	83	26	36	0,24	8	M7248P-1200AU-C0024	31237390
16,00	16	15,50	92	32	42	0,32	8	M7248P-1600AU-C0032	31237391

## Auf Anfrage erhältlich

20,00	20	19,40	104	38	52	0,40	8	M7248P-2000AU-C0040	31237392
-------	----	-------	-----	----	----	------	---	---------------------	----------

## Konfigurierbare Merkmale



**Schaftform:**  
Schaftform: HB



**Spezifikation:**  
M7248P-1200[**Schaftform**]U-C0024

**Beispiel:**  
M7248P-1200BU-C0024

Schaftform HB

Maßangaben in mm.  
Schnittwertempfehlung siehe Kapitelende.  
Sonderausführungen und andere Beschichtungen auf Anfrage.

# OptiMill®-Composite-Speed-Plus

Eckfräser, Ausführung mit schiebender Schneide  
M7258P

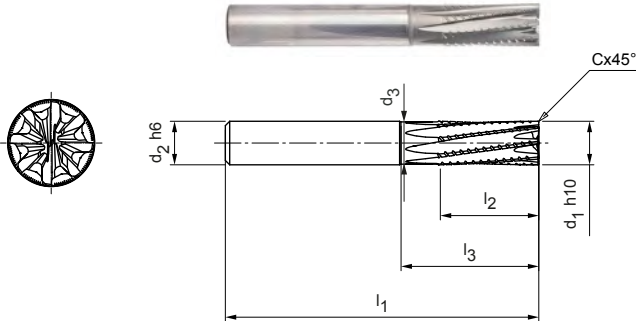

N	1.1	1.2	1.3	1.4	2.1	2.2	2.3	3.1	3.2	4.1	4.2	4.3	C	1.1	1.2	1.3	2.1	3.1	4.1	4.2	5.1	5.2	5.3	

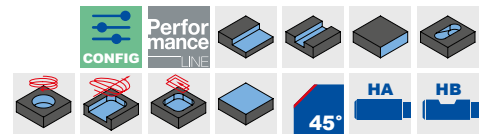

**Ausführung:**  
Fräserdurchmesser: 4,00 - 20,00 mm  
Beschichtung: Unbeschichtet  
Schneidenzahl: 8  
Spiralwinkel: -8°  
Besonderheiten: Ohne Beschichtung, extrem scharfe Schneidkanten

**Anwendung:**  
Schrupp- und Schlichtbearbeitung von CFK in einem Arbeitsgang. Schiebende Schneide, das Material wird auf die Unterlage gedrückt (z.B. bei Vakuumspannung sehr gut geeignet). Besonders geeignet für schwer zerspanbare Decklagen (z. B. UD oder Copper Mesh) zur Vermeidung von Delamination an der Bauteiloberkante.

## Lagerhaltige Vorzugsbaureihe

Baumaße							z	Spezifikation	Bestell-Nr.
d1 h10	d2 h6	d3	l1	l2	l3	Cx45°			
4,00	6	3,90	57	11	-	0,08	8	M7258P-0400AU-C0008	31242565
5,00	6	4,90	57	13	-	0,10	8	M7258P-0500AU-C0010	31242566
6,00	6	5,80	57	13	19	0,12	8	M7258P-0600AU-C0012	31242567
6,00	6	5,80	65	21	27	0,12	8	M7258P-0600AU-C0012	31242568
8,00	8	7,80	63	19	25	0,16	8	M7258P-0800AU-C0016	31242569
8,00	8	7,80	70	22	32	0,16	8	M7258P-0800AU-C0016	31242580
10,00	10	9,70	72	22	30	0,20	8	M7258P-1000AU-C0020	31242581
12,00	12	11,60	83	26	36	0,24	8	M7258P-1200AU-C0024	31242582
16,00	16	15,50	92	32	42	0,32	8	M7258P-1600AU-C0032	31242583

## Auf Anfrage erhältlich

20,00	20	19,40	104	38	52	0,40	8	M7258P-2000AU-C0040	31242584
-------	----	-------	-----	----	----	------	---	---------------------	----------

## Konfigurierbare Merkmale

**Schaftform:**  
Schaftform: HB

**Spezifikation:**  
M7258P-1200[**Schaftform**]U-C0024

**Beispiel:**  
M7258P-1200BU-C0024

Schaftform HB

Maßangaben in mm.  
Schnittwertempfehlung siehe Kapitelende.  
Sonderausführungen und andere Beschichtungen auf Anfrage.

# OptiMill®-Composite-Speed-Plus

Eckfräser, Ausführung mit ziehender Schneide  
M7228P, Nachfolgeprodukt von M7228

**Ausführung:**

Fräserdurchmesser: 4,00 - 20,00 mm  
Beschichtung: Diamant-Beschichtet  
Schneidenzahl: 8  
Spiralwinkel: 8°  
Besonderheiten: Diamantbeschichtung

**Anwendung:**

Schrupp- und Schlichtbearbeitung von CFK in einem Arbeitsgang. Ziehende Schneide für eine bessere Abfuhr der Späne/Stäube (z. B. beim Fräsen von Taschen und Nuten). Besonders geeignet für schwer zerspanbare Decklagen (z. B. UD oder Copper Mesh) zur Vermeidung von Delamination an der Bauteilunterkante.

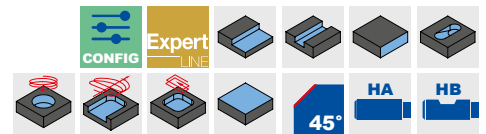
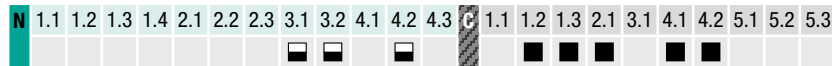
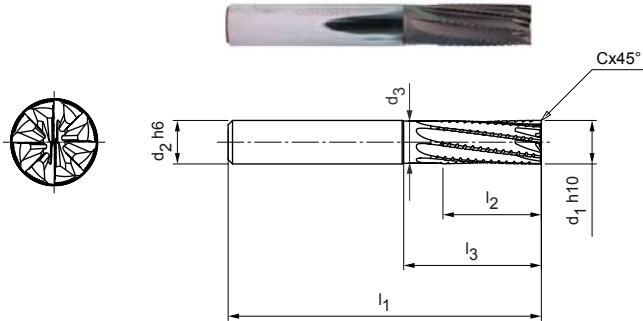

**Lagerhaltige Vorzugsbaureihe**

Baumaße							z	Spezifikation	Bestell-Nr.
d <sub>1</sub> h10	d <sub>2</sub> h6	d <sub>3</sub>	l <sub>1</sub>	l <sub>2</sub>	l <sub>3</sub>	Cx45°			
4,00	6	3,90	57	11	–	0,08	8	M7228P-0400AQ-C0008	31223317
5,00	6	4,90	57	13	–	0,10	8	M7228P-0500AQ-C0010	31223318
6,00	6	5,80	57	13	19	0,12	8	M7228P-0600AQ-C0012	31223319
6,00	6	5,80	65	21	27	0,12	8	M7228P-0600AQ-C0012	31223330
8,00	8	7,80	63	19	25	0,16	8	M7228P-0800AQ-C0016	31223331
8,00	8	7,80	70	22	32	0,16	8	M7228P-0800AQ-C0016	31223332
10,00	10	9,70	72	22	30	0,20	8	M7228P-1000AQ-C0020	31223333
12,00	12	11,60	83	26	36	0,24	8	M7228P-1200AQ-C0024	31223334
16,00	16	15,50	92	32	42	0,32	8	M7228P-1600AQ-C0032	31223335

**Auf Anfrage erhältlich**

20,00	20	19,40	104	38	52	0,40	8	M7228P-2000AQ-C0040	31223336
-------	----	-------	-----	----	----	------	---	---------------------	----------

**Konfigurierbare Merkmale**



**Schaftform:**  
Schaftform: HB



**Spezifikation:**  
M7228P-1200[**Schaftform**]Q-C0024

**Beispiel:**  
M7228P-1200**B**Q-C0024

\_\_\_\_\_ Schaftform HB

Maßangaben in mm.  
Schnittwertempfehlung siehe Kapitelende.  
Sonderausführungen und andere Beschichtungen auf Anfrage.

# OptiMill®-Composite-Speed-Plus

Eckfräser, Ausführung mit schiebender Schneide  
M7238P, Nachfolgeprodukt von M7238

**Ausführung:**

Fräserdurchmesser: 4,00 - 20,00 mm  
Beschichtung: Diamant-Beschichtet  
Schneidenzahl: 8  
Spiralwinkel: -8°  
Besonderheiten: Diamantbeschichtung

**Anwendung:**

Schrupp- und Schlichtbearbeitung von CFK in einem Arbeitsgang. Schiebende Schneide, das Material wird auf die Unterlage gedrückt (z.B bei Vakuumspannung sehr gut geeignet). Besonders geeignet für schwer zerspanbare Decklagen (z. B. UD oder Copper Mesh) zur Vermeidung von Delamination an der Bauteiloberkante.

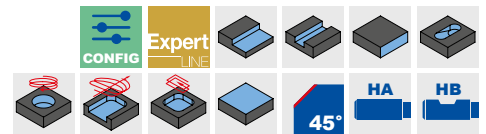
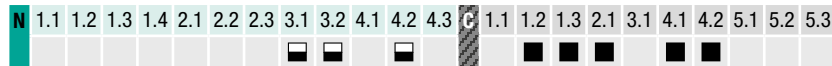
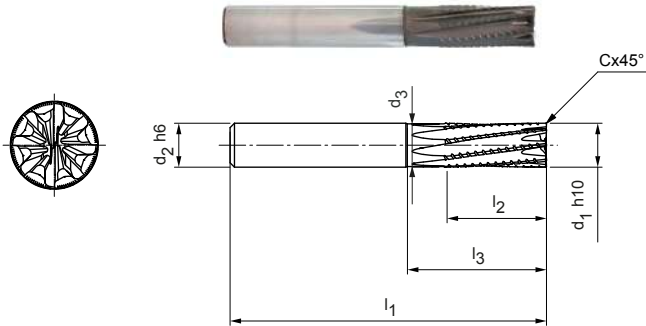

**Lagerhaltige Vorzugsbaureihe**

Baumaße							z	Spezifikation	Bestell-Nr.
d <sub>1</sub> h10	d <sub>2</sub> h6	d <sub>3</sub>	l <sub>1</sub>	l <sub>2</sub>	l <sub>3</sub>	Cx45°			
4,00	6	3,90	57	11	–	0,08	8	M7238P-0400AQ-C0008	31223337
5,00	6	4,90	57	13	–	0,10	8	M7238P-0500AQ-C0010	31223338
6,00	6	5,80	57	13	19	0,12	8	M7238P-0600AQ-C0012	31223339
6,00	6	5,80	65	21	27	0,12	8	M7238P-0600AQ-C0012	31223340
8,00	8	7,80	63	19	25	0,16	8	M7238P-0800AQ-C0016	31223341
8,00	8	7,80	70	22	32	0,16	8	M7238P-0800AQ-C0016	31223342
10,00	10	9,70	72	22	30	0,20	8	M7238P-1000AQ-C0020	31223343
12,00	12	11,60	83	26	36	0,24	8	M7238P-1200AQ-C0024	31223344
16,00	16	15,50	92	32	42	0,32	8	M7238P-1600AQ-C0032	31223345

**Auf Anfrage erhältlich**

20,00	20	19,40	104	38	52	0,40	8	M7238P-2000AQ-C0040	31223346
-------	----	-------	-----	----	----	------	---	---------------------	----------

**Konfigurierbare Merkmale**



**Schaftform:**  
Schaftform: HB



**Spezifikation:**  
M7238P-1200[**Schaftform**]Q-C0024

**Beispiel:**

M7238P-1200**BQ**-C0024

\_\_\_\_\_ Schaftform HB

Maßangaben in mm.

Schnittwertempfehlung siehe Kapitelende.

Sonderausführungen und andere Beschichtungen auf Anfrage.

# OptiMill®-Composite-Micro

Eckfräser, kurze Ausführung, ziehende Schneide  
M7901

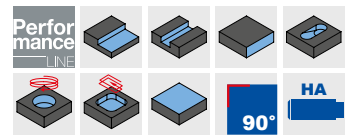
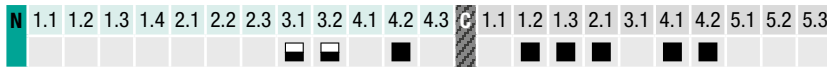
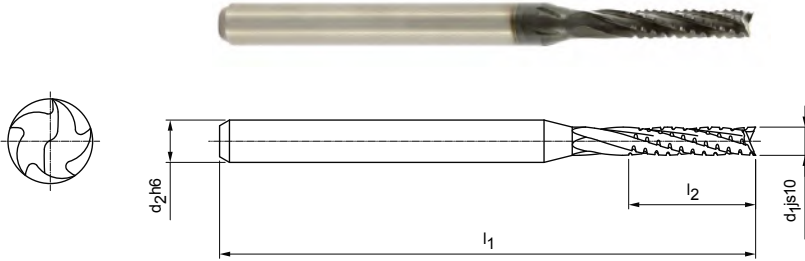

**Ausführung:**  
Fräserdurchmesser: 1,00 - 3,00 mm  
Beschichtung: Diamant-Beschichtung  
Schneidenzahl: Vielzahn  
Besonderheiten: Diamantbeschichtung

**Anwendung:**  
Ziehende Schneide für eine bessere Abfuhr der Späne/Stäube (z. B. beim Fräsen von Taschen und Nuten). Besonders geeignet für schwer zerspanbare Decklagen (z. B. UD oder Copper Mesh) zur Vermeidung von Delamination an der Bauteilunterkante.

### Lagerhaltige Vorzugsbaureihe

Baumaße				z	Spezifikation	Bestell-Nr.
d <sub>1</sub> js10	d <sub>2</sub> h6	l <sub>1</sub>	l <sub>2</sub>			
1,00	3	38	5	Vielzahn	M7901-0100AQ	30467717
2,00	3	38	9	Vielzahn	M7901-0200AQ	30467719
3,00	3	38	9	Vielzahn	M7901-0300AQ	30467721

Maßangaben in mm.  
Schnittwertempfehlung siehe Kapitelende.  
Sonderausführungen und andere Beschichtungen auf Anfrage.



# OptiMill®-Composite-Duo

Eckfräser, lange Ausführung  
M7222

## Ausführung:

Fräserdurchmesser: 3,00 - 20,00 mm  
Beschichtung: Diamant-Beschichtung  
Schneidenanzahl: 2  
Spiralwinkel: 15°  
Besonderheiten: Diamant-Beschichtung für hohe Standzeit

## Anwendung:

Zum Schlichten von Bauteilen aus CFK/GFK mit hohen Oberflächenanforderungen.

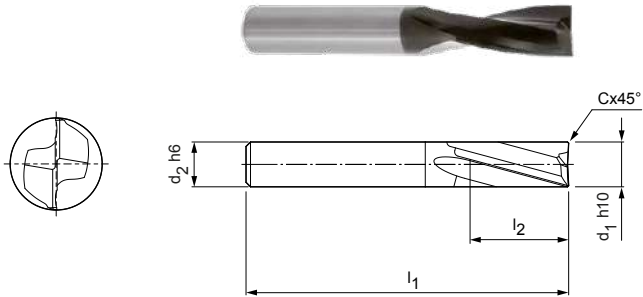

N	1.1	1.2	1.3	1.4	2.1	2.2	2.3	3.1	4.1	4.2	4.3	C	1.1	1.2	1.3	2.1	3.1	4.1	4.2	5.1	5.2	5.3	
								■				■		■									

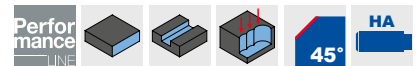

Baumaße					z	Spezifikation	Bestell-Nr.
d <sub>1</sub> h10	d <sub>2</sub> h6	l <sub>1</sub>	l <sub>2</sub>	C x 45°			
3,00	6	57	8	0,06	2	M7222-0300AQ	30355245
4,00	6	57	11	0,08	2	M7222-0400AQ	30355246
5,00	6	57	13	0,10	2	M7222-0500AQ	30355247
6,00	6	57	13	0,12	2	M7222-0600AQ	30355248
8,00	8	63	19	0,16	2	M7222-0800AQ	30355250
10,00	10	72	22	0,20	2	M7222-1000AQ	30340685
12,00	12	83	26	0,20	2	M7222-1200AQ	30355251
14,00	14	83	26	0,20	2	M7222-1400AQ	30355252
16,00	16	92	32	0,20	2	M7222-1600AQ	30355253
18,00	18	92	32	0,20	2	M7222-1800AQ	30355254
20,00	20	104	38	0,20	2	M7222-2000AQ	30355255

Maßangaben in mm.

Schnittwertempfehlung siehe Kapitelende.

Sonderausführungen und andere Beschichtungen auf Anfrage.

# OptiMill®-Composite-TwinCut

Eckfräser, extralange Ausführung  
M7402

**Ausführung:**  
Fräserdurchmesser: 4,00 - 20,00 mm  
Beschichtung: Unbeschichtet  
Schneidenzahl: 2  
Spiralwinkel: 0°  
Besonderheiten: Wechselseitige Anordnung der Schneiden

**Anwendung:**  
Zum Schrumpfen von aramidfaserverstärkten Kunststoffen. Vermeidung von Delamination bei geflochtenen Fasern und textilen Faserstrukturen.

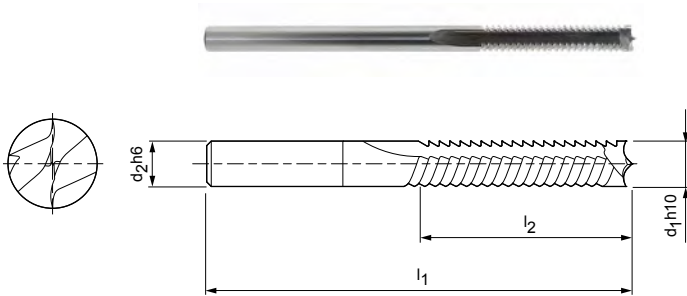

N	1.1	1.2	1.3	1.4	2.1	2.2	2.3	3.1	3.2	4.1	4.2	4.3	C	1.1	1.2	1.3	2.1	3.1	4.1	4.2	5.1	5.2	5.3
---	-----	-----	-----	-----	-----	-----	-----	-----	-----	-----	-----	-----	---	-----	-----	-----	-----	-----	-----	-----	-----	-----	-----

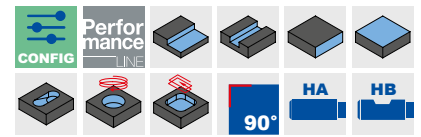

## Lagerhaltige Vorzugsbaureihe

Baumaße				z	Spezifikation	Bestell-Nr.
d <sub>1</sub> h10	d <sub>2</sub> h6	l <sub>1</sub>	l <sub>2</sub>			
4,00	4	75	20	2	M7402-0400AU GL=75	30290531
6,00	6	100	35	2	M7402-0600AU GL=100	30290533
8,00	8	100	40	2	M7402-0800AU GL=100	30290534

## Auf Anfrage erhältlich

5,00	5	75	25	2	M7402-0500AU GL=75	30290532
10,00	10	125	50	2	M7402-1000AU GL=125	30290535
12,00	12	125	60	2	M7402-1200AU GL=125	30290536
16,00	16	150	75	2	M7402-1600AU GL=150	30290537
20,00	20	104	45	2	M7402-2000AU GL=104	30290538

## Konfigurierbare Merkmale

**Schaftform:**  
Schaftform: HB

**Spezifikation:**  
M7402-1200[Schaftform]U GL=125

**Beispiel:**  
M7402-1200BU GL=125

Schaftform HB

Maßangaben in mm.  
Schnittwertempfehlung siehe Kapitelende.  
Sonderausführungen und andere Beschichtungen auf Anfrage.

# OptiMill®-Thermoplastic-FR

Eckfräser, überlange Ausführung  
M7644

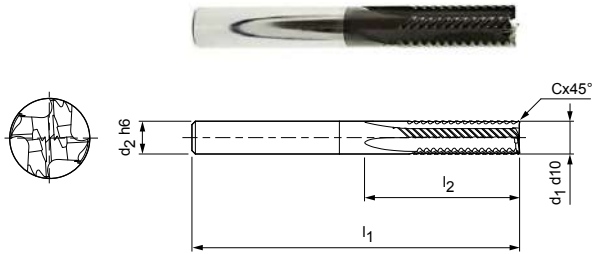

**Ausführung:**

Fräserdurchmesser: 6,00 - 20,00 mm  
 Beschichtung: Diamant-Beschichtet  
 Schneidenzahl: 4  
 Spiralwinkel: 0°  
 Besonderheiten: Diamantbeschichtung

**Anwendung:**

Für die Bearbeitung von Thermoplasten mit Faser-  
 verstärkung. Durch eine spezielle Hochleistungs-  
 verzahnung werden die Fasern ohne Gratbildung  
 sauber an der Schnittkante abgetrennt.

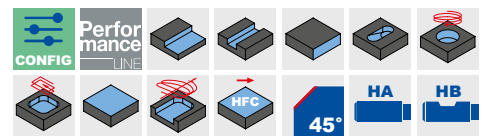

N	1.1	1.2	1.3	1.4	2.1	2.2	2.3	3.1	3.2	4.1	4.2	4.3	C	1.1	1.2	1.3	2.1	3.1	4.1	4.2	5.1	5.2	5.3
---	-----	-----	-----	-----	-----	-----	-----	-----	-----	-----	-----	-----	---	-----	-----	-----	-----	-----	-----	-----	-----	-----	-----

**Lagerhaltige Vorzugsbaureihe**

Baumaße					z	Spezifikation	Bestell-Nr.
d1 h10	d2 h6	l1	l2	Cx45°			
6,00	6	62	13	0,12	4	M7644-0600AQ-C0012	30661552
10,00	10	80	22	0,20	4	M7644-1000AQ-C0020	30661557

**Auf Anfrage erhältlich**

4,00	6	62	11	0,08	4	M7644-0400AQ-C0008	30661550
5,00	6	62	13	0,10	4	M7644-0500AQ-C0010	30661551
8,00	8	68	19	0,16	4	M7644-0800AQ-C0016	30661555
12,00	12	93	26	0,24	4	M7644-1200AQ-C0024	30661558
16,00	16	108	32	0,32	4	M7644-1600AQ-C0032	30661559
20,00	20	126	38	0,40	4	M7644-2000AQ-C0040	30661560

**Konfigurierbare Merkmale**



**Schaftform:**  
Schaftform: HB



**Spezifikation:**  
M7644-1200[Schaftform]Q-C0024

**Beispiel:**  
M7644-1200BQ-C0024

Schaftform HB

Maßangaben in mm.  
 Schnittwertempfehlung siehe Kapitelende.  
 Sonderausführungen und andere Beschichtungen auf Anfrage.

# OptiMill®-Mono-Plastic

Eckfräser, Ausführung mit ziehender/schiebender Schneide  
MN7MP1A

**Ausführung:**

Fräserdurchmesser:

2,00 - 12,00 mm

Beschichtung:

Unbeschichtet

Schneidenzahl:

1

Besonderheiten:

Großer Spanraum für ungehinderten Spanablauf

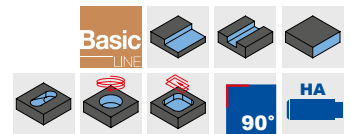
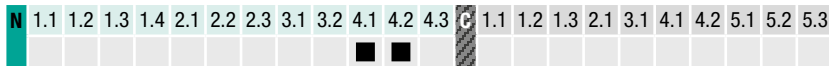
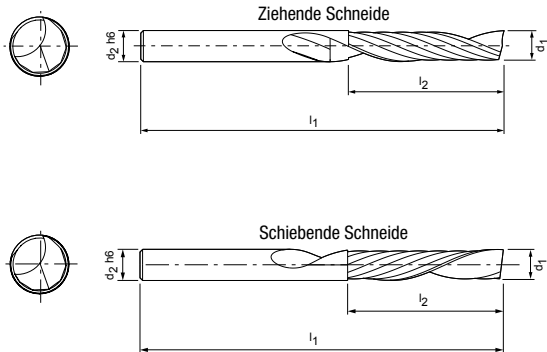

**Lagerhaltige Vorzugsbaureihe**

Baumaße				z	Spezifikation*	Bestell-Nr.	
d <sub>1</sub>	d <sub>2</sub> h6	l <sub>1</sub>	l <sub>2</sub>			ziehend	schiebend
2,00	3	38	8	1	MN7MP[Schnittverhalten]A-0200	30253277	30253278
3,00	3	38	10	1	MN7MP[Schnittverhalten]A-0300	30216602	30216634
3,00	4	38	10	1	MN7MP[Schnittverhalten]B-0300	30216609	-
3,00	4	50	15	1	MN7MP[Schnittverhalten]C-0300	30216610	30216637
3,00	6	50	10	1	MN7MP[Schnittverhalten]D-0300	30216611	30216638
4,00	4	40	12	1	MN7MP[Schnittverhalten]A-0400	30216615	30216641
4,00	4	60	20	1	MN7MP[Schnittverhalten]B-0400	30216616	-
4,00	4	70	30	1	MN7MP[Schnittverhalten]C-0400	30216617	-
4,00	6	50	15	1	MN7MP[Schnittverhalten]D-0400	30216618	30216644
5,00	5	50	16	1	MN7MP[Schnittverhalten]A-0500	30216620	30216646
5,00	5	70	30	1	MN7MP[Schnittverhalten]B-0500	30216621	-
6,00	6	60	20	1	MN7MP[Schnittverhalten]A-0600	30216622	30216647
6,00	6	70	30	1	MN7MP[Schnittverhalten]B-0600	30216623	30216648
6,00	6	80	38	1	MN7MP[Schnittverhalten]C-0600	30216624	-
8,00	8	60	25	1	MN7MP[Schnittverhalten]A-0800	30216627	30216650
8,00	8	80	38	1	MN7MP[Schnittverhalten]B-0800	30216628	30230395
10,00	10	75	30	1	MN7MP[Schnittverhalten]A-1000	30216629	-
12,00	12	75	30	1	MN7MP[Schnittverhalten]A-1200	30216630	-

Maßangaben in mm.

Schnittwertempfehlung siehe Kapitelende.

Sonderausführungen und andere Beschichtungen auf Anfrage.

\* Spezifikation zzgl. gewünschtem Schnittverhalten.

1 = ziehend | 2 = schiebend

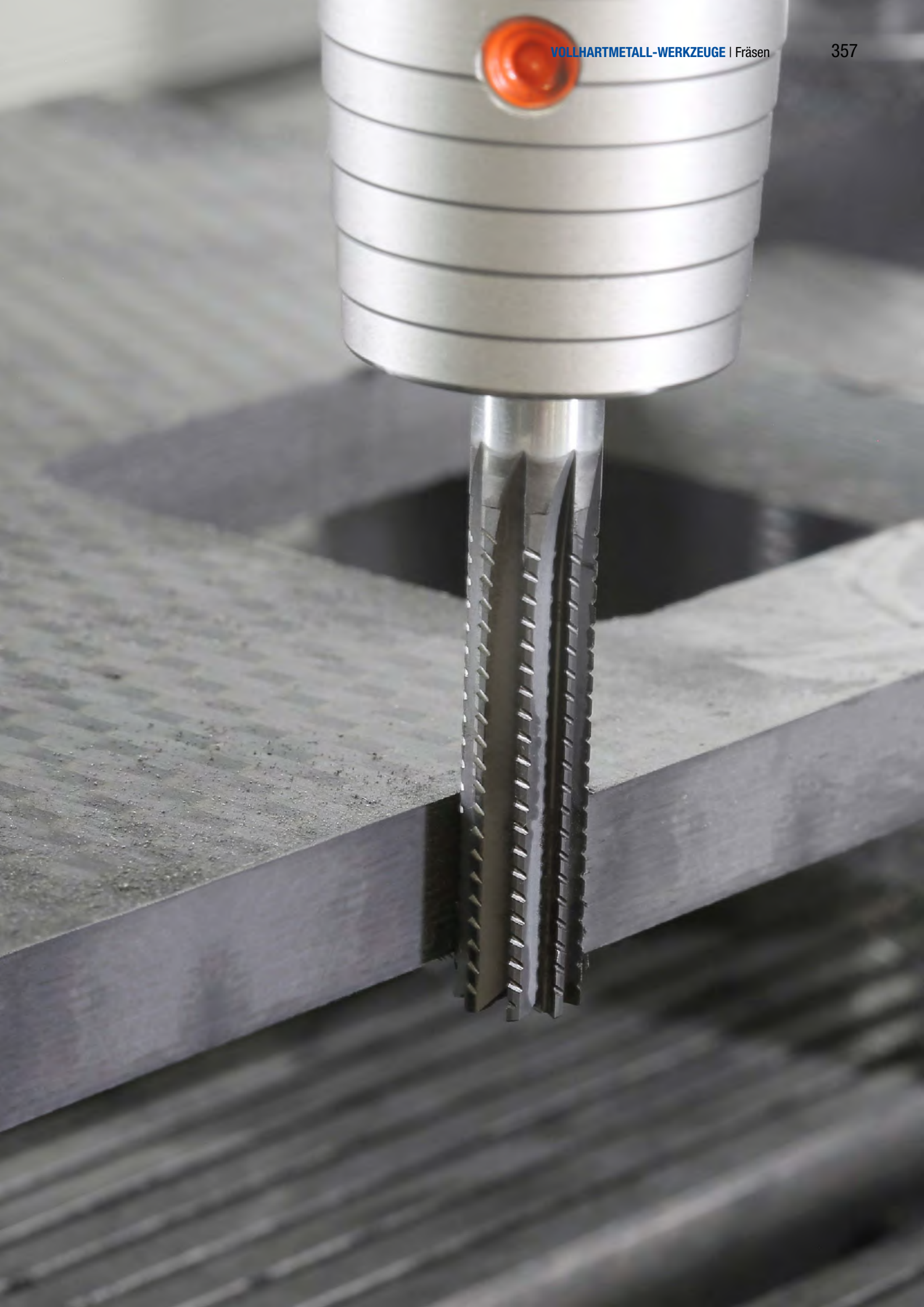

# Schnittwertempfehlung für Eckfräser

Vorschub und Schnittgeschwindigkeit

Werkzeuglänge/ Korrekturfaktor:	
Länge	$f_z$ & $v_c$
kurz	1
lang	0,9
überlang	0,8
extra lang	0,6

Nutfräsen

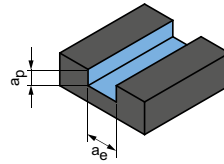

$$a_p = 1xD$$

$$a_e = 1xD$$

OptiMill-Uni-HPC-Plus | M3090P, M3094P, M3190P, M3194P

MZG*	Werkstoff		Festigkeit/ Härte [N/mm <sup>2</sup> ] [HRC]	Kühlung			$v_c$ [m/min]	$f_z$ [mm]								
				MMS/Luft	Trocken	KSS		Fräserdurchmesser [mm]								
								2,00	4,00	6,00	8,00	10,00	12,00	16,00	20,00	
P	P1	P1.1	Bau-, Automaten-, Einsatz- und Vergütungsstähle, unlegiert	< 700	✓	✓	✓	<b>175</b>	0,013	0,024	0,035	0,044	0,053	0,061	0,075	0,085
		P1.2	Bau-, Automaten-, Einsatz- und Vergütungsstähle, unlegiert	< 1.200	✓	✓	✓	<b>145</b>	0,012	0,023	0,032	0,041	0,050	0,057	0,070	0,080
	P2	P2.1	Nitrier-, Einsatz- und Vergütungsstähle, legiert	< 900	✓	✓	✓	<b>160</b>	0,013	0,024	0,035	0,044	0,053	0,061	0,075	0,085
		P2.2	Nitrier-, Einsatz- und Vergütungsstähle, legiert	< 1.400	✓	✓	✓	<b>110</b>	0,011	0,020	0,029	0,037	0,044	0,051	0,062	0,071
	P3	P3.1	Werkzeug-, Wälzlager-, Feder- und Schnellarbeitsstähle**	< 800	✓	✓	✓	<b>105</b>	0,012	0,023	0,034	0,043	0,051	0,059	0,072	0,082
		P3.2	Werkzeug-, Wälzlager-, Feder- und Schnellarbeitsstähle**	< 1.000	✓		✓	<b>95</b>	0,012	0,022	0,032	0,041	0,049	0,056	0,068	0,078
		P3.3	Werkzeug-, Wälzlager-, Feder- und Schnellarbeitsstähle**	< 1.500	✓		✓	<b>85</b>	0,011	0,021	0,030	0,038	0,046	0,053	0,065	0,074
	P4	P4.1	Rostfreie Stähle, ferritisch und martensitisch		✓		✓	<b>70</b>	0,008	0,016	0,023	0,030	0,035	0,041	0,050	0,057
P5	P5.1	Stahlguss				✓	<b>105</b>	0,012	0,023	0,034	0,043	0,051	0,059	0,072	0,082	
P6	P6.1	Rostfreier Stahlguss, ferritisch und martensitisch				✓	<b>70</b>	0,006	0,011	0,016	0,021	0,025	0,028	0,035	0,040	
M	M1	M1.1	Rostfreie Stähle, austenitisch	< 700	✓		✓	<b>50</b>	0,007	0,014	0,020	0,026	0,031	0,036	0,043	0,050
		M1.2	Rostfreie Stähle, ferritisch/austenitisch (Duplex)	< 1.000			✓	<b>45</b>	0,006	0,012	0,017	0,021	0,026	0,029	0,036	0,041
	M2	M2.1	Rostfreier Stahlguss, austenitisch	< 700	✓		✓	<b>50</b>	0,008	0,015	0,022	0,028	0,034	0,039	0,047	0,054
	M3	M3.1	Rostfreier Stahlguss, ferritisch/austenitisch (Duplex)	< 1.000			✓	<b>50</b>	0,006	0,012	0,017	0,022	0,027	0,031	0,037	0,043
K	K1	K1.1	Gusseisen mit Lamellengraphit (Grauguss), GJL	< 300	✓	✓	✓	<b>190</b>	0,021	0,040	0,058	0,074	0,088	0,102	0,124	0,142
		K2.1	Gusseisen mit Kugelgraphit, GJS	< 500	✓	✓	✓	<b>175</b>	0,018	0,034	0,049	0,063	0,075	0,086	0,106	0,121
		K2.2	Gusseisen mit Kugelgraphit, GJS	≤ 800	✓	✓	✓	<b>145</b>	0,015	0,028	0,040	0,052	0,062	0,071	0,087	0,099
	K2	K2.3	Gusseisen mit Kugelgraphit, GJS	> 800	✓	✓	✓	<b>80</b>	0,008	0,016	0,023	0,030	0,035	0,041	0,050	0,057
		K3.1	Gusseisen mit Vermiculargraphit, GJV; Temperguss, GJM	< 500	✓	✓	✓	<b>125</b>	0,015	0,028	0,040	0,052	0,062	0,071	0,087	0,099
	K3	K3.2	Gusseisen mit Vermiculargraphit, GJV; Temperguss, GJM	> 500	✓	✓	✓	<b>120</b>	0,013	0,024	0,035	0,044	0,053	0,061	0,075	0,085

OptiMill-Uni-HPC-Plus | M3092P

MZG*	Werkstoff		Festigkeit/ Härte [N/mm <sup>2</sup> ] [HRC]	Kühlung			$v_c$ [m/min]	$f_z$ [mm]								
				MMS/Luft	Trocken	KSS		Fräserdurchmesser [mm]								
								1,00	3,00	6,00	8,00	10,00	12,00	16,00	20,00	
P	P1	P1.1	Bau-, Automaten-, Einsatz- und Vergütungsstähle, unlegiert	< 700	✓	✓	✓	<b>200</b>	0,007	0,020	0,038	0,049	0,058	0,067	0,082	0,094
		P1.2	Bau-, Automaten-, Einsatz- und Vergütungsstähle, unlegiert	< 1.200	✓	✓	✓	<b>165</b>	0,007	0,019	0,036	0,046	0,054	0,063	0,077	0,087
	P2	P2.1	Nitrier-, Einsatz- und Vergütungsstähle, legiert	< 900	✓	✓	✓	<b>180</b>	0,007	0,020	0,038	0,049	0,058	0,067	0,082	0,094
		P2.2	Nitrier-, Einsatz- und Vergütungsstähle, legiert	< 1.400	✓	✓	✓	<b>125</b>	0,006	0,017	0,032	0,041	0,049	0,056	0,068	0,078
	P3	P3.1	Werkzeug-, Wälzlager-, Feder- und Schnellarbeitsstähle**	< 800	✓	✓	✓	<b>120</b>	0,007	0,020	0,037	0,047	0,056	0,065	0,079	0,091
		P3.2	Werkzeug-, Wälzlager-, Feder- und Schnellarbeitsstähle**	< 1.000	✓		✓	<b>110</b>	0,007	0,019	0,035	0,045	0,054	0,062	0,075	0,086
		P3.3	Werkzeug-, Wälzlager-, Feder- und Schnellarbeitsstähle**	< 1.500	✓		✓	<b>100</b>	0,006	0,018	0,033	0,042	0,051	0,058	0,071	0,081
	P4	P4.1	Rostfreie Stähle, ferritisch und martensitisch		✓		✓	<b>80</b>	0,005	0,014	0,025	0,033	0,039	0,045	0,055	0,062
P5	P5.1	Stahlguss				✓	<b>120</b>	0,007	0,020	0,037	0,047	0,056	0,065	0,079	0,091	
P6	P6.1	Rostfreier Stahlguss, ferritisch und martensitisch				✓	<b>80</b>	0,003	0,010	0,018	0,023	0,027	0,031	0,038	0,044	
M	M1	M1.1	Rostfreie Stähle, austenitisch	< 700	✓		✓	<b>55</b>	0,004	0,012	0,022	0,028	0,034	0,039	0,048	0,055
		M1.2	Rostfreie Stähle, ferritisch/austenitisch (Duplex)	< 1.000			✓	<b>50</b>	0,003	0,010	0,018	0,024	0,028	0,032	0,040	0,045
	M2	M2.1	Rostfreier Stahlguss, austenitisch	< 700	✓		✓	<b>60</b>	0,005	0,013	0,024	0,031	0,037	0,042	0,052	0,059
	M3	M3.1	Rostfreier Stahlguss, ferritisch/austenitisch (Duplex)	< 1.000			✓	<b>55</b>	0,004	0,010	0,019	0,024	0,029	0,034	0,041	0,047
K	K1	K1.1	Gusseisen mit Lamellengraphit (Grauguss), GJL	< 300	✓	✓	✓	<b>215</b>	0,012	0,034	0,064	0,081	0,097	0,112	0,137	0,156
		K2.1	Gusseisen mit Kugelgraphit, GJS	< 500	✓	✓	✓	<b>200</b>	0,010	0,029	0,054	0,069	0,083	0,095	0,116	0,133
		K2.2	Gusseisen mit Kugelgraphit, GJS	≤ 800	✓	✓	✓	<b>160</b>	0,008	0,024	0,045	0,057	0,068	0,078	0,096	0,109
	K2	K2.3	Gusseisen mit Kugelgraphit, GJS	> 800	✓	✓	✓	<b>90</b>	0,005	0,014	0,025	0,033	0,039	0,045	0,055	0,062
		K3.1	Gusseisen mit Vermiculargraphit, GJV; Temperguss, GJM	< 500	✓	✓	✓	<b>145</b>	0,008	0,024	0,045	0,057	0,068	0,078	0,096	0,109
	K3	K3.2	Gusseisen mit Vermiculargraphit, GJV; Temperguss, GJM	> 500	✓	✓	✓	<b>135</b>	0,007	0,020	0,038	0,049	0,058	0,067	0,082	0,094

\* MILLER Zerspanungsgruppen

\*\* Wenn die Legierungsbestandteile Cr, Mo, Ni, V, W in Summe > 8 %, dann die nächst höhere MILLER Zerspanungsgruppe wählen.

**Schruppen**

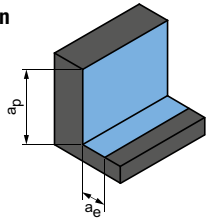

$a_p = 1,5xD$   
 $a_e = 0,25xD$

**Schichten**

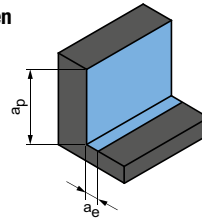

$a_p = 1,5xD$   
 $a_e = 0,1xD$

	$v_c$ [m/min]	$f_z$ [mm]								$v_c$ [m/min]	$f_z$ [mm]							
		Fräserdurchmesser [mm]									Fräserdurchmesser [mm]							
		2,00	4,00	6,00	8,00	10,00	12,00	16,00	20,00		2,00	4,00	6,00	8,00	10,00	12,00	16,00	20,00
355	0,021	0,041	0,059	0,075	0,090	0,103	0,126	0,145	525	0,034	0,065	0,093	0,119	0,142	0,164	0,200	0,228	
290	0,020	0,038	0,055	0,070	0,084	0,097	0,118	0,135	430	0,032	0,060	0,087	0,111	0,133	0,153	0,187	0,213	
325	0,021	0,041	0,059	0,075	0,090	0,103	0,126	0,145	475	0,034	0,065	0,093	0,119	0,142	0,164	0,200	0,228	
225	0,018	0,034	0,049	0,063	0,075	0,086	0,105	0,120	335	0,028	0,054	0,078	0,099	0,119	0,136	0,167	0,190	
210	0,021	0,040	0,057	0,073	0,087	0,100	0,122	0,140	310	0,033	0,063	0,090	0,115	0,138	0,158	0,193	0,221	
195	0,020	0,038	0,054	0,069	0,083	0,095	0,116	0,132	285	0,031	0,059	0,085	0,109	0,130	0,150	0,183	0,209	
180	0,019	0,035	0,051	0,065	0,078	0,090	0,110	0,125	260	0,029	0,056	0,081	0,103	0,123	0,142	0,173	0,198	
145	0,014	0,027	0,039	0,050	0,060	0,069	0,084	0,096	215	0,023	0,043	0,062	0,079	0,095	0,109	0,133	0,152	
215	0,021	0,040	0,057	0,073	0,087	0,100	0,122	0,140	320	0,033	0,063	0,090	0,115	0,138	0,158	0,193	0,221	
145	0,010	0,019	0,027	0,035	0,042	0,048	0,059	0,067	215	0,016	0,030	0,043	0,055	0,066	0,076	0,093	0,107	
95	0,012	0,024	0,034	0,044	0,053	0,060	0,074	0,084	145	0,020	0,038	0,054	0,069	0,083	0,095	0,117	0,133	
90	0,010	0,020	0,028	0,036	0,044	0,050	0,061	0,070	135	0,016	0,031	0,045	0,057	0,069	0,079	0,097	0,110	
105	0,014	0,026	0,037	0,048	0,057	0,066	0,080	0,092	155	0,021	0,041	0,059	0,075	0,090	0,104	0,127	0,145	
95	0,011	0,020	0,029	0,038	0,045	0,052	0,063	0,072	145	0,017	0,032	0,047	0,059	0,071	0,082	0,100	0,114	
390	0,036	0,068	0,098	0,125	0,150	0,172	0,211	0,241	570	0,056	0,108	0,155	0,198	0,237	0,273	0,333	0,381	
355	0,030	0,058	0,083	0,106	0,128	0,147	0,179	0,205	525	0,048	0,092	0,132	0,168	0,202	0,232	0,283	0,324	
290	0,025	0,048	0,069	0,088	0,105	0,121	0,147	0,169	430	0,040	0,076	0,109	0,139	0,166	0,191	0,233	0,267	
160	0,014	0,027	0,039	0,050	0,060	0,069	0,084	0,096	240	0,023	0,043	0,062	0,079	0,095	0,109	0,133	0,152	
260	0,025	0,048	0,069	0,088	0,105	0,121	0,147	0,169	380	0,040	0,076	0,109	0,139	0,166	0,191	0,233	0,267	
245	0,021	0,041	0,059	0,075	0,090	0,103	0,126	0,145	355	0,034	0,065	0,093	0,119	0,142	0,164	0,200	0,228	

	$v_c$ [m/min]	$f_z$ [mm]								$v_c$ [m/min]	$f_z$ [mm]							
		Fräserdurchmesser [mm]									Fräserdurchmesser [mm]							
		1,00	3,00	6,00	8,00	10,00	12,00	16,00	20,00		1,00	3,00	6,00	8,00	10,00	12,00	16,00	20,00
355	0,012	0,035	0,065	0,083	0,099	0,114	0,139	0,159	480	0,019	0,055	0,102	0,131	0,157	0,180	0,220	0,251	
290	0,011	0,032	0,060	0,077	0,092	0,106	0,130	0,148	395	0,018	0,051	0,096	0,122	0,146	0,168	0,205	0,235	
325	0,012	0,035	0,065	0,083	0,099	0,114	0,139	0,159	435	0,019	0,055	0,102	0,131	0,157	0,180	0,220	0,251	
225	0,010	0,029	0,054	0,069	0,083	0,095	0,116	0,132	305	0,016	0,045	0,085	0,109	0,130	0,150	0,183	0,209	
210	0,012	0,033	0,063	0,080	0,096	0,110	0,134	0,154	285	0,019	0,053	0,099	0,126	0,151	0,174	0,213	0,243	
195	0,011	0,032	0,059	0,076	0,091	0,104	0,127	0,146	260	0,018	0,050	0,094	0,120	0,144	0,165	0,202	0,230	
180	0,011	0,030	0,056	0,072	0,086	0,099	0,120	0,138	240	0,017	0,047	0,089	0,113	0,136	0,156	0,191	0,218	
145	0,008	0,023	0,043	0,055	0,066	0,076	0,093	0,106	195	0,013	0,036	0,068	0,087	0,104	0,120	0,147	0,168	
215	0,012	0,033	0,063	0,080	0,096	0,110	0,134	0,154	295	0,019	0,053	0,099	0,126	0,151	0,174	0,213	0,243	
145	0,006	0,016	0,030	0,039	0,046	0,053	0,065	0,074	195	0,009	0,025	0,048	0,061	0,073	0,084	0,103	0,117	
110	0,007	0,020	0,038	0,048	0,058	0,066	0,081	0,093	160	0,011	0,032	0,060	0,076	0,091	0,105	0,128	0,147	
105	0,006	0,017	0,031	0,040	0,048	0,055	0,067	0,077	150	0,009	0,026	0,049	0,063	0,076	0,087	0,106	0,121	
120	0,008	0,022	0,041	0,052	0,063	0,072	0,088	0,101	180	0,012	0,035	0,065	0,083	0,099	0,114	0,139	0,159	
110	0,006	0,017	0,032	0,041	0,050	0,057	0,070	0,079	160	0,010	0,027	0,051	0,065	0,078	0,090	0,110	0,126	
440	0,020	0,058	0,108	0,138	0,165	0,190	0,232	0,265	650	0,032	0,091	0,171	0,218	0,261	0,300	0,366	0,419	
405	0,017	0,049	0,092	0,117	0,140	0,161	0,197	0,225	595	0,027	0,077	0,145	0,185	0,222	0,255	0,311	0,356	
330	0,014	0,040	0,076	0,096	0,116	0,133	0,162	0,185	485	0,022	0,064	0,119	0,153	0,183	0,210	0,256	0,293	
185	0,008	0,023	0,043	0,055	0,066	0,076	0,093	0,106	270	0,013	0,036	0,068	0,087	0,104	0,120	0,147	0,168	
295	0,014	0,040	0,076	0,096	0,116	0,133	0,162	0,185	430	0,022	0,064	0,119	0,153	0,183	0,210	0,256	0,293	
275	0,012	0,035	0,065	0,083	0,099	0,114	0,139	0,159	405	0,019	0,055	0,102	0,131	0,157	0,180	0,220	0,251	

Die angegebenen Arbeitswerte sind Richtwerte.  
Die für den jeweiligen Bearbeitungsfall optimalen Daten sollten im Versuch oder während der Bearbeitung ermittelt werden.

# Schnittwertempfehlung für Eckfräser

Vorschub und Schnittgeschwindigkeit

Werkzeuglänge/ Korrekturfaktor:	
Länge	$f_z$ & $v_c$
kurz	1
lang	0,9
überlang	0,8
extra lang	0,6

Nutfräsen

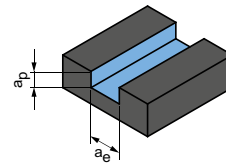

$$a_p = 1 \times D$$

$$a_e = 1 \times D$$

## OptiMill-Uni-HPC-Slot | M3293

MZG*	Werkstoff	Festigkeit/ Härte [N/mm <sup>2</sup> ] [HRC]	Kühlung			$v_c$ [m/min]	$f_z$ [mm]								
			MMS/Luft	Trocken	KSS		Fräserdurchmesser [mm]								
							2,00	4,00	6,00	8,00	10,00	12,00	16,00	20,00	
P	P1.1	Bau-, Automaten-, Einsatz- und Vergütungsstähle, unlegiert	< 700	✓	✓	✓	200	0,013	0,024	0,035	0,044	0,053	0,061	0,075	0,085
	P1.2	Bau-, Automaten-, Einsatz- und Vergütungsstähle, unlegiert	< 1.200	✓	✓	✓	165	0,012	0,023	0,032	0,041	0,050	0,057	0,070	0,080
	P2.1	Nitrier-, Einsatz- und Vergütungsstähle, legiert	< 900	✓	✓	✓	180	0,013	0,024	0,035	0,044	0,053	0,061	0,075	0,085
	P2.2	Nitrier-, Einsatz- und Vergütungsstähle, legiert	< 1.400	✓	✓	✓	125	0,011	0,020	0,029	0,037	0,044	0,051	0,062	0,071
	P3.1	Werkzeug-, Wälzlager-, Feder- und Schnellarbeitsstähle**	< 800	✓	✓	✓	120	0,012	0,023	0,034	0,043	0,051	0,059	0,072	0,082
	P3.2	Werkzeug-, Wälzlager-, Feder- und Schnellarbeitsstähle**	< 1.000	✓	✓	✓	110	0,012	0,022	0,032	0,041	0,049	0,056	0,068	0,078
	P3.3	Werkzeug-, Wälzlager-, Feder- und Schnellarbeitsstähle**	< 1.500	✓	✓	✓	100	0,011	0,021	0,030	0,038	0,046	0,053	0,065	0,074
	P4.1	Rostfreie Stähle, ferritisch und martensitisch		✓	✓	✓	80	0,008	0,016	0,023	0,030	0,035	0,041	0,050	0,057
	P5.1	Stahlguss				✓	120	0,012	0,023	0,034	0,043	0,051	0,059	0,072	0,082
	P6.1	Rostfreier Stahlguss, ferritisch und martensitisch				✓	80	0,006	0,011	0,016	0,021	0,025	0,028	0,035	0,040
M	M1.1	Rostfreie Stähle, austenitisch	< 700	✓		✓	55	0,007	0,014	0,020	0,026	0,031	0,036	0,043	0,050
	M1.2	Rostfreie Stähle, ferritisch/austenitisch (Duplex)	< 1.000			✓	50	0,006	0,012	0,017	0,021	0,026	0,029	0,036	0,041
	M2.1	Rostfreier Stahlguss, austenitisch	< 700	✓		✓	60	0,008	0,015	0,022	0,028	0,034	0,039	0,047	0,054
	M3.1	Rostfreier Stahlguss, ferritisch/austenitisch (Duplex)	< 1.000			✓	55	0,006	0,012	0,017	0,022	0,027	0,031	0,037	0,043
K	K1.1	Gusseisen mit Lamellengraphit (Grauguss), GJL	< 300	✓	✓	✓	215	0,021	0,040	0,058	0,074	0,088	0,102	0,124	0,142
	K2.1	Gusseisen mit Kugelgraphit, GJS	< 500	✓	✓	✓	200	0,018	0,034	0,049	0,063	0,075	0,086	0,106	0,121
	K2.2	Gusseisen mit Kugelgraphit, GJS	≤ 800	✓	✓	✓	160	0,015	0,028	0,040	0,052	0,062	0,071	0,087	0,099
	K2.3	Gusseisen mit Kugelgraphit, GJS	> 800	✓	✓	✓	90	0,008	0,016	0,023	0,030	0,035	0,041	0,050	0,057
	K3.1	Gusseisen mit Vermiculargraphit, GJV; Temperguss, GJM	< 500	✓	✓	✓	145	0,015	0,028	0,040	0,052	0,062	0,071	0,087	0,099
	K3.2	Gusseisen mit Vermiculargraphit, GJV; Temperguss, GJM	> 500	✓	✓	✓	135	0,013	0,024	0,035	0,044	0,053	0,061	0,075	0,085

\* MILLER Zerspanungsgruppen

\*\* Wenn die Legierungsbestandteile Cr, Mo, Ni, V, W in Summe > 8 %, dann die nächst höhere MILLER Zerspanungsgruppe wählen.



**Schruppen**

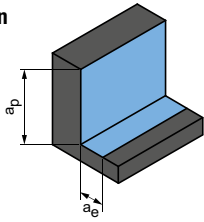

$a_p = 1,5xD$   
 $a_e = 0,25xD$

**Schlichten**

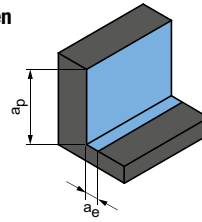

$a_p = 1,5xD$   
 $a_e = 0,1xD$

	$v_c$ [m/min]	$f_z$ [mm]								$v_c$ [m/min]	$f_z$ [mm]							
		Fräserdurchmesser [mm]									Fräserdurchmesser [mm]							
		2,00	4,00	6,00	8,00	10,00	12,00	16,00	20,00		2,00	4,00	6,00	8,00	10,00	12,00	16,00	20,00
	<b>355</b>	0,021	0,041	0,059	0,075	0,090	0,103	0,126	0,145	<b>480</b>	0,034	0,065	0,093	0,119	0,142	0,164	0,200	0,228
	<b>290</b>	0,020	0,038	0,055	0,070	0,084	0,097	0,118	0,135	<b>395</b>	0,032	0,060	0,087	0,111	0,133	0,153	0,187	0,213
	<b>325</b>	0,021	0,041	0,059	0,075	0,090	0,103	0,126	0,145	<b>435</b>	0,034	0,065	0,093	0,119	0,142	0,164	0,200	0,228
	<b>225</b>	0,018	0,034	0,049	0,063	0,075	0,086	0,105	0,120	<b>305</b>	0,028	0,054	0,078	0,099	0,119	0,136	0,167	0,190
	<b>210</b>	0,021	0,040	0,057	0,073	0,087	0,100	0,122	0,140	<b>285</b>	0,033	0,063	0,090	0,115	0,138	0,158	0,193	0,221
	<b>195</b>	0,020	0,038	0,054	0,069	0,083	0,095	0,116	0,132	<b>260</b>	0,031	0,059	0,085	0,109	0,130	0,150	0,183	0,209
	<b>180</b>	0,019	0,035	0,051	0,065	0,078	0,090	0,110	0,125	<b>240</b>	0,029	0,056	0,081	0,103	0,123	0,142	0,173	0,198
	<b>145</b>	0,014	0,027	0,039	0,050	0,060	0,069	0,084	0,096	<b>195</b>	0,023	0,043	0,062	0,079	0,095	0,109	0,133	0,152
	<b>215</b>	0,021	0,040	0,057	0,073	0,087	0,100	0,122	0,140	<b>295</b>	0,033	0,063	0,090	0,115	0,138	0,158	0,193	0,221
	<b>145</b>	0,010	0,019	0,027	0,035	0,042	0,048	0,059	0,067	<b>195</b>	0,016	0,030	0,043	0,055	0,066	0,076	0,093	0,107
	<b>110</b>	0,012	0,024	0,034	0,044	0,053	0,060	0,074	0,084	<b>160</b>	0,020	0,038	0,054	0,069	0,083	0,095	0,117	0,133
	<b>105</b>	0,010	0,020	0,028	0,036	0,044	0,050	0,061	0,070	<b>150</b>	0,016	0,031	0,045	0,057	0,069	0,079	0,097	0,110
	<b>120</b>	0,014	0,026	0,037	0,048	0,057	0,066	0,080	0,092	<b>180</b>	0,021	0,041	0,059	0,075	0,090	0,104	0,127	0,145
	<b>110</b>	0,011	0,020	0,029	0,038	0,045	0,052	0,063	0,072	<b>160</b>	0,017	0,032	0,047	0,059	0,071	0,082	0,100	0,114
	<b>440</b>	0,036	0,068	0,098	0,125	0,150	0,172	0,211	0,241	<b>650</b>	0,056	0,108	0,155	0,198	0,237	0,273	0,333	0,381
	<b>405</b>	0,030	0,058	0,083	0,106	0,128	0,147	0,179	0,205	<b>595</b>	0,048	0,092	0,132	0,168	0,202	0,232	0,283	0,324
	<b>330</b>	0,025	0,048	0,069	0,088	0,105	0,121	0,147	0,169	<b>485</b>	0,040	0,076	0,109	0,139	0,166	0,191	0,233	0,267
	<b>185</b>	0,014	0,027	0,039	0,050	0,060	0,069	0,084	0,096	<b>270</b>	0,023	0,043	0,062	0,079	0,095	0,109	0,133	0,152
	<b>295</b>	0,025	0,048	0,069	0,088	0,105	0,121	0,147	0,169	<b>430</b>	0,040	0,076	0,109	0,139	0,166	0,191	0,233	0,267
	<b>275</b>	0,021	0,041	0,059	0,075	0,090	0,103	0,126	0,145	<b>405</b>	0,034	0,065	0,093	0,119	0,142	0,164	0,200	0,228

Die angegebenen Arbeitswerte sind Richtwerte.

Die für den jeweiligen Bearbeitungsfall optimalen Daten sollten im Versuch oder während der Bearbeitung ermittelt werden.

# Schnittwertempfehlung für Eckfräser

Vorschub und Schnittgeschwindigkeit

Werkzeuflänge/ Korrekturfaktor:	
Länge	$f_z$ & $v_c$
kurz	1
lang	1
überlang	0,8
extra lang	-

Schruppen

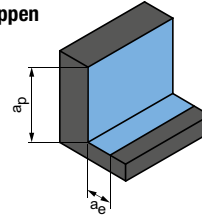

$$a_p = 1,5xD$$

$$a_e = 0,25xD$$

**OptiMill-Uni-HPC-Pocket I M3993, M3990, M3991**

MZG*	Werkstoff	Festigkeit/ Härte [N/mm²] [HRC]	Kühlung			$v_c$ [m/min]	$f_z$ [mm]							
			MMS/Luft	Trocken	KSS		Fräserdurchmesser [mm]							
							3,80	6,00	8,00	10,00	12,00	16,00	20,00	
P	P1.1	Bau-, Automaten-, Einsatz- und Vergütungsstähle, unlegiert	< 700	✓	✓	✓	465	0,053	0,079	0,101	0,122	0,140	0,171	0,195
	P1.2	Bau-, Automaten-, Einsatz- und Vergütungsstähle, unlegiert	< 1.200	✓	✓	✓	380	0,049	0,074	0,095	0,113	0,130	0,159	0,182
	P2.1	Nitrier-, Einsatz- und Vergütungsstähle, legiert	< 900	✓	✓	✓	425	0,053	0,079	0,101	0,122	0,140	0,171	0,195
	P2.2	Nitrier-, Einsatz- und Vergütungsstähle, legiert	< 1.400	✓	✓	✓	295	0,044	0,066	0,085	0,101	0,116	0,142	0,163
	P3.1	Werkzeug-, Wälzlager-, Feder- und Schnellarbeitsstähle**	< 800	✓	✓	✓	275	0,051	0,077	0,098	0,117	0,135	0,165	0,189
	P3.2	Werkzeug-, Wälzlager-, Feder- und Schnellarbeitsstähle**	< 1.000	✓		✓	255	0,048	0,073	0,093	0,111	0,128	0,156	0,179
	P3.3	Werkzeug-, Wälzlager-, Feder- und Schnellarbeitsstähle**	< 1.500	✓		✓	235	0,046	0,069	0,088	0,105	0,121	0,148	0,169
	P4.1	Rostfreie Stähle, ferritisch und martensitisch		✓		✓	190	0,035	0,053	0,068	0,081	0,093	0,114	0,130
	P5.1	Stahlguss				✓	285	0,051	0,077	0,098	0,117	0,135	0,165	0,189
P6.1	Rostfreier Stahlguss, ferritisch und martensitisch				✓	190	0,025	0,037	0,047	0,057	0,065	0,080	0,091	
M	M1.1	Rostfreie Stähle, austenitisch	< 700	✓		✓	125	0,031	0,046	0,059	0,071	0,081	0,100	0,114
	M1.2	Rostfreie Stähle, ferritisch/austenitisch (Duplex)	< 1.000			✓	120	0,025	0,038	0,049	0,059	0,068	0,082	0,094
	M2.1	Rostfreier Stahlguss, austenitisch	< 700	✓		✓	140	0,033	0,050	0,064	0,077	0,088	0,108	0,124
	M3.1	Rostfreier Stahlguss, ferritisch/austenitisch (Duplex)	< 1.000			✓	125	0,026	0,040	0,051	0,061	0,070	0,085	0,098
K	K1.1	Gusseisen mit Lamellengraphit (Grauguss), GJL	< 300	✓	✓	✓	510	0,088	0,132	0,169	0,203	0,233	0,284	0,325
	K2.1	Gusseisen mit Kugelgraphit, GJS	< 500	✓	✓	✓	465	0,075	0,113	0,144	0,172	0,198	0,242	0,276
	K2.2	Gusseisen mit Kugelgraphit, GJS	≤ 800	✓	✓	✓	380	0,062	0,093	0,118	0,142	0,163	0,199	0,228
	K2.3	Gusseisen mit Kugelgraphit, GJS	> 800	✓	✓	✓	210	0,035	0,053	0,068	0,081	0,093	0,114	0,130
	K3.1	Gusseisen mit Vermiculargraphit, GJV; Temperguss, GJM	< 500	✓	✓	✓	340	0,062	0,093	0,118	0,142	0,163	0,199	0,228
	K3.2	Gusseisen mit Vermiculargraphit, GJV; Temperguss, GJM	> 500	✓	✓	✓	315	0,053	0,079	0,101	0,122	0,140	0,171	0,195

\* MILLER Zerspanungsgruppen

\*\* Wenn die Legierungsbestandteile Cr, Mo, Ni, V, W in Summe > 8 %, dann die nächst höhere MILLER Zerspanungsgruppe wählen.

**Nutfräsen**

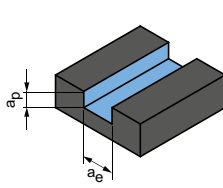

$a_p = 1xD$   
 $a_e = 1xD$

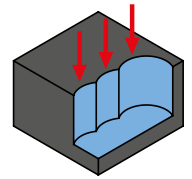
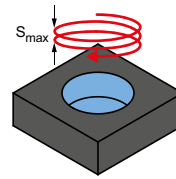
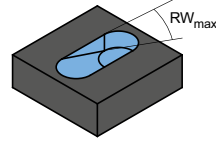

$v_c$ [m/min]	$f_z$ [mm]								Rampen	Helixfräsen		Bohren	
	Fräserdurchmesser [mm]								$RW_{max}$	$S_{max}$	$EW_{max}$		$f_z$ Faktor
	3,80	6,00	8,00	10,00	12,00	16,00	20,00			G = 1,5	G = 1,8		
<b>230</b>	0,031	0,047	0,060	0,072	0,082	0,101	0,115	45°	0,75xD	25°	16°	0,9	
<b>185</b>	0,029	0,044	0,056	0,067	0,077	0,094	0,107	45°	0,75xD	25°	16°	0,8	
<b>205</b>	0,031	0,047	0,060	0,072	0,082	0,101	0,115	45°	0,75xD	25°	16°	0,8	
<b>145</b>	0,026	0,039	0,050	0,060	0,069	0,084	0,096	45°	0,75xD	25°	16°	0,7	
<b>135</b>	0,030	0,045	0,058	0,069	0,080	0,097	0,111	30°	0,5xD	18°	11°	0,8	
<b>125</b>	0,029	0,043	0,055	0,066	0,075	0,092	0,105	30°	0,5xD	18°	11°	0,7	
<b>115</b>	0,027	0,041	0,052	0,062	0,071	0,087	0,100	30°	0,5xD	18°	11°	0,7	
<b>95</b>	0,021	0,031	0,040	0,048	0,055	0,067	0,077	15°	0,5xD	18°	11°		
<b>140</b>	0,030	0,045	0,058	0,069	0,080	0,097	0,111	30°	0,5xD	18°	11°		
<b>95</b>	0,015	0,022	0,028	0,033	0,038	0,047	0,054	15°	0,5xD	18°	11°		
<b>60</b>	0,018	0,027	0,035	0,042	0,048	0,059	0,067	15°	0,5xD	18°	11°		
<b>60</b>	0,015	0,023	0,029	0,035	0,040	0,049	0,056	15°	0,5xD	18°	11°		
<b>70</b>	0,020	0,030	0,038	0,045	0,052	0,064	0,073	15°	0,5xD	18°	11°		
<b>60</b>	0,016	0,023	0,030	0,036	0,041	0,050	0,058	15°	0,5xD	18°	11°		
<b>250</b>	0,052	0,078	0,100	0,119	0,137	0,168	0,192	45°	0,75xD	25°	16°	0,8	
<b>230</b>	0,044	0,066	0,085	0,102	0,117	0,143	0,163	45°	0,75xD	25°	16°	0,8	
<b>185</b>	0,036	0,055	0,070	0,084	0,096	0,117	0,134	45°	0,75xD	25°	16°	0,8	
<b>105</b>	0,021	0,031	0,040	0,048	0,055	0,067	0,077	45°	0,75xD	25°	16°	0,8	
<b>165</b>	0,036	0,055	0,070	0,084	0,096	0,117	0,134	45°	0,75xD	25°	16°	0,8	
<b>155</b>	0,031	0,047	0,060	0,072	0,082	0,101	0,115	45°	0,75xD	25°	16°	0,8	

Die angegebenen Arbeitswerte sind Richtwerte.

Die für den jeweiligen Bearbeitungsfall optimalen Daten sollten im Versuch oder während der Bearbeitung ermittelt werden.

# Schnittwertempfehlung für Eckfräser

Vorschub und Schnittgeschwindigkeit

Werkzeuglänge/ Korrekturfaktor:	
Länge	f <sub>z</sub> & v <sub>c</sub>
kurz	1
lang	0,9
überlang	0,8
extra lang	0,6

Nutfräsen - Teilnut

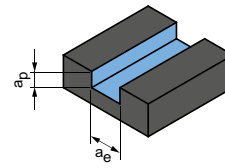

$$a_p = 1xD$$

$$a_e = 0,6xD$$

## OptiMill-Uni-HPC-Silent I M3095

MZG*	Werkstoff	Festigkeit/ Härte [N/mm <sup>2</sup> ] [HRC]	Kühlung			v <sub>c</sub> [m/min]	f <sub>z</sub> [mm]								
			MMS/Luft	Trocken	KSS		Fräserdurchmesser [mm]								
							6,00	8,00	10,00	12,00	16,00	20,00	25,00		
<b>P</b>	P1.1	Bau-, Automaten-, Einsatz- und Vergütungsstähle, unlegiert	< 700	✓	✓	✓	<b>235</b>	0,045	0,057	0,069	0,079	0,096	0,110	0,123	
		Bau-, Automaten-, Einsatz- und Vergütungsstähle, unlegiert	< 1.200	✓	✓	✓	<b>190</b>	0,042	0,053	0,064	0,074	0,090	0,103	0,115	
	P2	P2.1	Nitrier-, Einsatz- und Vergütungsstähle, legiert	< 900	✓	✓	✓	<b>210</b>	0,045	0,057	0,069	0,079	0,096	0,110	0,123
		P2.2	Nitrier-, Einsatz- und Vergütungsstähle, legiert	< 1.400	✓	✓	✓	<b>150</b>	0,037	0,048	0,057	0,066	0,080	0,092	0,102
	P3	P3.1	Werkzeug-, Wälzlager-, Feder- und Schnellarbeitsstähle**	< 800	✓	✓	✓	<b>135</b>	0,043	0,055	0,066	0,076	0,093	0,106	0,119
		P3.2	Werkzeug-, Wälzlager-, Feder- und Schnellarbeitsstähle**	< 1.000	✓	✓	✓	<b>125</b>	0,041	0,052	0,063	0,072	0,088	0,101	0,113
		P3.3	Werkzeug-, Wälzlager-, Feder- und Schnellarbeitsstähle**	< 1.500	✓	✓	✓	<b>115</b>	0,039	0,050	0,059	0,068	0,083	0,095	0,106
	P4	P4.1	Rostfreie Stähle, ferritisch und martensitisch		✓	✓	✓	<b>95</b>	0,030	0,038	0,046	0,053	0,064	0,073	0,082
	P5	P5.1	Stahlguss			✓	✓	<b>140</b>	0,043	0,055	0,066	0,076	0,093	0,106	0,119
P6	P6.1	Rostfreier Stahlguss, ferritisch und martensitisch			✓	✓	<b>95</b>	0,021	0,027	0,032	0,037	0,045	0,051	0,057	
<b>M</b>	M1	M1.1	Rostfreie Stähle, austenitisch	< 700	✓	✓	✓	<b>65</b>	0,026	0,033	0,040	0,046	0,056	0,064	0,072
		M1.2	Rostfreie Stähle, ferritisch/austenitisch (Duplex)	< 1.000			✓	<b>60</b>	0,022	0,028	0,033	0,038	0,046	0,053	0,059
	M2	M2.1	Rostfreier Stahlguss, austenitisch	< 700	✓	✓	✓	<b>70</b>	0,028	0,036	0,043	0,050	0,061	0,070	0,078
	M3	M3.1	Rostfreier Stahlguss, ferritisch/austenitisch (Duplex)	< 1.000			✓	<b>65</b>	0,022	0,029	0,034	0,039	0,048	0,055	0,061
<b>K</b>	K1	K1.1	Gusseisen mit Lamellengraphit (Grauguss), GJL	< 300	✓	✓	✓	<b>250</b>	0,075	0,095	0,114	0,131	0,160	0,183	0,205
		K2.1	Gusseisen mit Kugelgraphit, GJS	< 500	✓	✓	✓	<b>230</b>	0,063	0,081	0,097	0,112	0,136	0,156	0,174
		K2.2	Gusseisen mit Kugelgraphit, GJS	≤ 800	✓	✓	✓	<b>190</b>	0,052	0,067	0,080	0,092	0,112	0,128	0,143
	K2	K2.3	Gusseisen mit Kugelgraphit, GJS	> 800	✓	✓	✓	<b>105</b>	0,030	0,038	0,046	0,053	0,064	0,073	0,082
		K3	K3.1	Gusseisen mit Vermiculargraphit, GJV; Temperguss, GJM	< 500	✓	✓	✓	<b>170</b>	0,052	0,067	0,080	0,092	0,112	0,128
	K3.2		Gusseisen mit Vermiculargraphit, GJV; Temperguss, GJM	> 500	✓	✓	✓	<b>160</b>	0,045	0,057	0,069	0,079	0,096	0,110	0,123

## ECU-Mill-Uni-LV I M4090, M4094

MZG*	Werkstoff	Festigkeit/ Härte [N/mm <sup>2</sup> ] [HRC]	Kühlung			v <sub>c</sub> [m/min]	f <sub>z</sub> [mm]								
			MMS/Luft	Trocken	KSS		Fräserdurchmesser [mm]								
							6,00	8,00	10,00	12,00	16,00	20,00	25,00		
<b>P</b>	P1	P1.1	Bau-, Automaten-, Einsatz- und Vergütungsstähle, unlegiert	< 700	✓	✓	✓	<b>170</b>	0,022	0,031	0,040	0,048	0,055	0,067	0,077
		P1.2	Bau-, Automaten-, Einsatz- und Vergütungsstähle, unlegiert	< 1.200	✓	✓	✓	<b>140</b>	0,020	0,029	0,037	0,045	0,051	0,063	0,072
	P2	P2.1	Nitrier-, Einsatz- und Vergütungsstähle, legiert	< 900	✓	✓	✓	<b>155</b>	0,022	0,031	0,040	0,048	0,055	0,067	0,077
		P2.2	Nitrier-, Einsatz- und Vergütungsstähle, legiert	< 1.400	✓	✓	✓	<b>110</b>	0,018	0,026	0,033	0,040	0,046	0,056	0,064
	P3	P3.1	Werkzeug-, Wälzlager-, Feder- und Schnellarbeitsstähle**	< 800	✓	✓	✓	<b>100</b>	0,021	0,030	0,039	0,046	0,053	0,065	0,074
		P3.2	Werkzeug-, Wälzlager-, Feder- und Schnellarbeitsstähle**	< 1.000	✓	✓	✓	<b>95</b>	0,020	0,029	0,037	0,044	0,050	0,061	0,070
		P3.3	Werkzeug-, Wälzlager-, Feder- und Schnellarbeitsstähle**	< 1.500	✓	✓	✓	<b>85</b>	0,019	0,027	0,035	0,041	0,048	0,058	0,066
P5	P5.1	Stahlguss			✓	✓	<b>105</b>	0,021	0,030	0,039	0,046	0,053	0,065	0,074	
<b>K</b>	K1	K1.1	Gusseisen mit Lamellengraphit (Grauguss), GJL	< 300	✓	✓	✓	<b>185</b>	0,036	0,052	0,066	0,080	0,092	0,112	0,128
		K2.1	Gusseisen mit Kugelgraphit, GJS	< 500	✓	✓	✓	<b>170</b>	0,031	0,044	0,057	0,068	0,078	0,095	0,109
		K2.2	Gusseisen mit Kugelgraphit, GJS	≤ 800	✓	✓	✓	<b>140</b>	0,025	0,036	0,047	0,056	0,064	0,078	0,089
	K2	K2.3	Gusseisen mit Kugelgraphit, GJS	> 800	✓	✓	✓	<b>75</b>	0,014	0,021	0,027	0,032	0,037	0,045	0,051
		K3	K3.1	Gusseisen mit Vermiculargraphit, GJV; Temperguss, GJM	< 500	✓	✓	✓	<b>120</b>	0,025	0,036	0,047	0,056	0,064	0,078
	K3.2		Gusseisen mit Vermiculargraphit, GJV; Temperguss, GJM	> 500	✓	✓	✓	<b>115</b>	0,022	0,031	0,040	0,048	0,055	0,067	0,077

\* MILLER Zerspanungsgruppen

\*\* Wenn die Legierungsbestandteile Cr, Mo, Ni, V, W in Summe > 8 %, dann die nächst höhere MILLER Zerspanungsgruppe wählen.

**Schruppen**

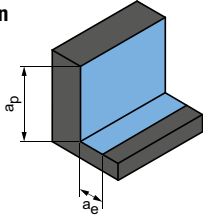

$$a_p = 1,5xD$$

$$a_e = 0,25xD$$

**Schlichten**

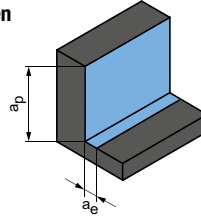

$$a_p = 1,5xD$$

$$a_e = 0,1xD$$

$v_c$ [m/min]	$f_z$ [mm]							$v_c$ [m/min]	$f_z$ [mm]						
	Fräserdurchmesser [mm]								Fräserdurchmesser [mm]						
	6,00	8,00	10,00	12,00	16,00	20,00	25,00		6,00	8,00	10,00	12,00	16,00	20,00	25,00
<b>355</b>	0,059	0,075	0,090	0,103	0,126	0,145	0,161	<b>480</b>	0,093	0,119	0,142	0,164	0,200	0,228	0,255
<b>290</b>	0,055	0,070	0,084	0,097	0,118	0,135	0,151	<b>395</b>	0,087	0,111	0,133	0,153	0,187	0,213	0,238
<b>325</b>	0,059	0,075	0,090	0,103	0,126	0,145	0,161	<b>435</b>	0,093	0,119	0,142	0,164	0,200	0,228	0,255
<b>225</b>	0,049	0,063	0,075	0,086	0,105	0,120	0,134	<b>305</b>	0,078	0,099	0,119	0,136	0,167	0,190	0,212
<b>210</b>	0,057	0,073	0,087	0,100	0,122	0,140	0,156	<b>285</b>	0,090	0,115	0,138	0,158	0,193	0,221	0,246
<b>195</b>	0,054	0,069	0,083	0,095	0,116	0,132	0,148	<b>260</b>	0,085	0,109	0,130	0,150	0,183	0,209	0,234
<b>180</b>	0,051	0,065	0,078	0,090	0,110	0,125	0,140	<b>240</b>	0,081	0,103	0,123	0,142	0,173	0,198	0,221
<b>145</b>	0,039	0,050	0,060	0,069	0,084	0,096	0,108	<b>195</b>	0,062	0,079	0,095	0,109	0,133	0,152	0,170
<b>215</b>	0,057	0,073	0,087	0,100	0,122	0,140	0,156	<b>295</b>	0,090	0,115	0,138	0,158	0,193	0,221	0,246
<b>145</b>	0,027	0,035	0,042	0,048	0,059	0,067	0,075	<b>195</b>	0,043	0,055	0,066	0,076	0,093	0,107	0,119
<b>110</b>	0,034	0,044	0,053	0,060	0,074	0,084	0,094	<b>160</b>	0,054	0,069	0,083	0,095	0,117	0,133	0,149
<b>105</b>	0,028	0,036	0,044	0,050	0,061	0,070	0,078	<b>150</b>	0,045	0,057	0,069	0,079	0,097	0,110	0,123
<b>120</b>	0,037	0,048	0,057	0,066	0,080	0,092	0,102	<b>180</b>	0,059	0,075	0,090	0,104	0,127	0,145	0,161
<b>110</b>	0,029	0,038	0,045	0,052	0,063	0,072	0,081	<b>160</b>	0,047	0,059	0,071	0,082	0,100	0,114	0,127
<b>440</b>	0,098	0,125	0,150	0,172	0,211	0,241	0,269	<b>650</b>	0,155	0,198	0,237	0,273	0,333	0,381	0,425
<b>405</b>	0,083	0,106	0,128	0,147	0,179	0,205	0,228	<b>595</b>	0,132	0,168	0,202	0,232	0,283	0,324	0,361
<b>330</b>	0,069	0,088	0,105	0,121	0,147	0,169	0,188	<b>485</b>	0,109	0,139	0,166	0,191	0,233	0,267	0,297
<b>185</b>	0,039	0,050	0,060	0,069	0,084	0,096	0,108	<b>270</b>	0,062	0,079	0,095	0,109	0,133	0,152	0,170
<b>295</b>	0,069	0,088	0,105	0,121	0,147	0,169	0,188	<b>430</b>	0,109	0,139	0,166	0,191	0,233	0,267	0,297
<b>275</b>	0,059	0,075	0,090	0,103	0,126	0,145	0,161	<b>405</b>	0,093	0,119	0,142	0,164	0,200	0,228	0,255

$v_c$ [m/min]	$f_z$ [mm]							$v_c$ [m/min]	$f_z$ [mm]						
	Fräserdurchmesser [mm]								Fräserdurchmesser [mm]						
	6,00	8,00	10,00	12,00	16,00	20,00	25,00		6,00	8,00	10,00	12,00	16,00	20,00	25,00
<b>305</b>	0,043	0,062	0,080	0,096	0,110	0,134	0,153	<b>410</b>	0,069	0,099	0,126	0,151	0,174	0,212	0,242
<b>250</b>	0,041	0,058	0,074	0,089	0,102	0,125	0,143	<b>335</b>	0,064	0,092	0,118	0,141	0,162	0,198	0,226
<b>275</b>	0,043	0,062	0,080	0,096	0,110	0,134	0,153	<b>370</b>	0,069	0,099	0,126	0,151	0,174	0,212	0,242
<b>195</b>	0,036	0,052	0,066	0,080	0,092	0,112	0,128	<b>260</b>	0,057	0,082	0,105	0,126	0,145	0,177	0,202
<b>180</b>	0,042	0,060	0,077	0,092	0,106	0,130	0,148	<b>240</b>	0,066	0,095	0,122	0,146	0,168	0,205	0,234
<b>165</b>	0,040	0,057	0,073	0,088	0,101	0,123	0,141	<b>225</b>	0,063	0,090	0,116	0,138	0,159	0,194	0,222
<b>150</b>	0,038	0,054	0,069	0,083	0,095	0,116	0,133	<b>205</b>	0,060	0,086	0,109	0,131	0,150	0,184	0,210
<b>185</b>	0,042	0,060	0,077	0,092	0,106	0,130	0,148	<b>250</b>	0,066	0,095	0,122	0,146	0,168	0,205	0,234
<b>375</b>	0,072	0,104	0,133	0,159	0,183	0,224	0,256	<b>550</b>	0,114	0,165	0,210	0,252	0,289	0,353	0,404
<b>345</b>	0,062	0,088	0,113	0,135	0,156	0,190	0,217	<b>505</b>	0,097	0,140	0,179	0,214	0,246	0,300	0,344
<b>280</b>	0,051	0,073	0,093	0,111	0,128	0,156	0,179	<b>415</b>	0,080	0,115	0,147	0,176	0,203	0,247	0,283
<b>155</b>	0,029	0,042	0,053	0,064	0,073	0,089	0,102	<b>230</b>	0,046	0,066	0,084	0,101	0,116	0,141	0,162
<b>250</b>	0,051	0,073	0,093	0,111	0,128	0,156	0,179	<b>365</b>	0,080	0,115	0,147	0,176	0,203	0,247	0,283
<b>235</b>	0,043	0,062	0,080	0,096	0,110	0,134	0,153	<b>345</b>	0,069	0,099	0,126	0,151	0,174	0,212	0,242

Die angegebenen Arbeitswerte sind Richtwerte.  
Die für den jeweiligen Bearbeitungsfall optimalen Daten sollten im Versuch oder während der Bearbeitung ermittelt werden.

# Schnittwertempfehlung für Eckfräser

Vorschub und Schnittgeschwindigkeit

## OptiMill-Hardened | M3274, M3271

MZG*	Werkstoff	Festigkeit/Härte [N/mm²] [HRC]	Kühlung			
			MMS/Luft	Trocken	KSS	
P	P1.1	Bau-, Automaten-, Einsatz- und Vergütungsstähle, unlegiert	< 700	✓	✓	✓
	P1.2	Bau-, Automaten-, Einsatz- und Vergütungsstähle, unlegiert	< 1.200	✓	✓	✓
	P2.1	Nitrier-, Einsatz- und Vergütungsstähle, legiert	< 900	✓	✓	✓
	P2.2	Nitrier-, Einsatz- und Vergütungsstähle, legiert	< 1.400	✓	✓	✓
	P3.1	Werkzeug-, Wälzlager-, Feder- und Schnellarbeitsstähle**	< 800	✓	✓	✓
	P3.2	Werkzeug-, Wälzlager-, Feder- und Schnellarbeitsstähle**	< 1.000	✓	✓	✓
	P3.3	Werkzeug-, Wälzlager-, Feder- und Schnellarbeitsstähle**	< 1.500	✓	✓	✓
	P4	P4.1	Rostfreie Stähle, ferritisch und martensitisch		✓	✓
	P5	P5.1	Stahlguss		✓	✓
	P6	P6.1	Rostfreier Stahlguss, ferritisch und martensitisch		✓	✓
H	H1.1	Gehärteter Stahl/Stahlguss	< 44	✓	✓	
	H1.2	Gehärteter Stahl/Stahlguss	< 55	✓	✓	
	H2	H2.1	Gehärteter Stahl/Stahlguss	< 60	✓	

### Nutfräsen

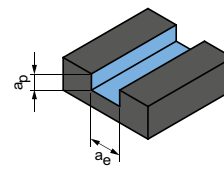

$$a_p = 1xD$$

$$a_e = 1xD$$

## OptiMill-Inox-HPC | M3644

MZG*	Werkstoff	Festigkeit/Härte [N/mm²] [HRC]	Kühlung			vc [m/min]	fz [mm]							
			MMS/Luft	Trocken	KSS		Fräserdurchmesser [mm]							
							3,00	4,00	6,00	8,00	10,00	12,00	16,00	20,00
M	M1.1	Rostfreie Stähle, austenitisch	< 700	✓	✓	70	0,011	0,013	0,019	0,025	0,030	0,035	0,044	0,051
	M1.2	Rostfreie Stähle, ferritisch/austenitisch (Duplex)	< 1.000		✓	65	0,009	0,011	0,016	0,020	0,025	0,029	0,036	0,042
	M2.1	Rostfreier Stahlguss, austenitisch	< 700	✓	✓	75	0,011	0,015	0,021	0,027	0,032	0,038	0,047	0,055
	M3.1	Rostfreier Stahlguss, ferritisch/austenitisch (Duplex)	< 1.000		✓	70	0,009	0,012	0,016	0,021	0,026	0,030	0,037	0,043

### Nutfräsen

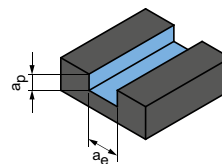

$$a_p = 1xD$$

$$a_e = 1xD$$

## OptiMill-Titan-HPC | M3614

MZG*	Werkstoff	Festigkeit/Härte [N/mm²] [HRC]	Kühlung			vc [m/min]	fz [mm/Zahn]						
			MMS/Luft	Trocken	KSS		Fräserdurchmesser [mm]						
							6,00	8,00	10,00	12,00	16,00	20,00	25,00
S	S1.1	Titan, Titanlegierungen	< 400		✓	85	0,035	0,045	0,054	0,062	0,075	0,086	0,096
	S2.1	Titan, Titanlegierungen	< 1.200		✓	80	0,029	0,037	0,044	0,050	0,061	0,070	0,078
	S2.2	Titan, Titanlegierungen	> 1.200		✓	50	0,025	0,033	0,039	0,045	0,055	0,062	0,070

\* MILLER Zerspanungsgruppen

\*\* Wenn die Legierungsbestandteile Cr, Mo, Ni, V, W in Summe > 8 %, dann die nächst höhere MILLER Zerspanungsgruppe wählen.

Schruppen

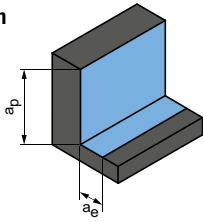

$a_p$ [mm] in % vom D	$a_e$ [mm] in % vom D	$v_c$ [m/min]	$f_z$ [mm]								
			Fräserdurchmesser [mm]								
			4,00	5,00	6,00	8,00	10,00	12,00	16,00	20,00	
50	8	180 - 200	0,032	0,040	0,048	0,055	0,075	0,095	0,110	0,140	
50	8	160 - 180	0,030	0,038	0,046	0,052	0,071	0,090	0,105	0,133	
50	8	170 - 190	0,032	0,040	0,048	0,055	0,075	0,095	0,110	0,140	
50	8	150 - 170	0,030	0,038	0,046	0,052	0,071	0,090	0,105	0,133	
50	8	170 - 190	0,032	0,040	0,048	0,055	0,075	0,095	0,110	0,140	
50	7	150 - 170	0,030	0,038	0,046	0,052	0,071	0,090	0,105	0,133	
50	7	130 - 150	0,027	0,034	0,041	0,047	0,064	0,081	0,094	0,119	
50	7	130 - 150	0,027	0,034	0,041	0,047	0,064	0,081	0,094	0,119	
50	7	130 - 150	0,027	0,034	0,041	0,047	0,064	0,081	0,094	0,119	
50	8	140 - 160	0,029	0,036	0,043	0,050	0,068	0,086	0,099	0,126	
50	2	100 - 125	0,027	0,034	0,041	0,047	0,064	0,081	0,094	0,119	
50	1,5	80 - 100	0,022	0,028	0,034	0,039	0,053	0,067	0,077	0,098	
50	1,2	60 - 80	0,019	0,024	0,029	0,033	0,045	0,057	0,066	0,084	

Schruppen

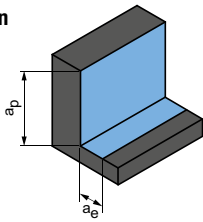

$a_p = 1,5xD$   
 $a_e = 0,25xD$

Schlichten

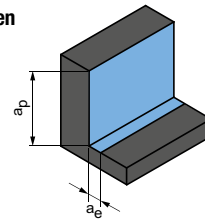

$a_p = 1,5xD$   
 $a_e = 0,1xD$

$v_c$ [m/min]	$f_z$ [mm]								$v_c$ [m/min]	$f_z$ [mm]							
	Fräserdurchmesser [mm]									Fräserdurchmesser [mm]							
	3,00	4,00	6,00	8,00	10,00	12,00	16,00	20,00		3,00	4,00	6,00	8,00	10,00	12,00	16,00	20,00
110	0,018	0,023	0,033	0,042	0,051	0,059	0,074	0,086	160	0,028	0,036	0,051	0,066	0,080	0,093	0,117	0,135
105	0,015	0,019	0,027	0,035	0,042	0,049	0,061	0,071	150	0,023	0,030	0,043	0,055	0,066	0,077	0,097	0,112
120	0,019	0,025	0,035	0,045	0,055	0,064	0,080	0,093	180	0,031	0,039	0,056	0,072	0,087	0,101	0,127	0,147
110	0,015	0,020	0,028	0,036	0,043	0,051	0,063	0,073	160	0,024	0,031	0,044	0,057	0,069	0,080	0,100	0,116

Schruppen

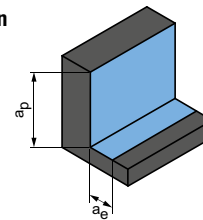

$a_p = 1,5xD$   
 $a_e = 0,25xD$

Schlichten

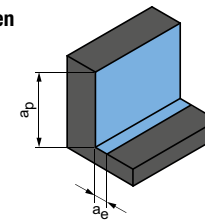

$a_p = 1,5xD$   
 $a_e = 0,1xD$

$v_c$ [m/min]	$f_z$ [mm/Zahn]							$v_c$ [m/min]	$f_z$ [mm/Zahn]						
	Fräserdurchmesser [mm]								Fräserdurchmesser [mm]						
	6,00	8,00	10,00	12,00	16,00	20,00	25,00		6,00	8,00	10,00	12,00	16,00	20,00	25,00
135	0,059	0,076	0,091	0,104	0,127	0,146	0,163	160	0,094	0,120	0,144	0,165	0,202	0,230	0,257
120	0,049	0,062	0,074	0,085	0,104	0,119	0,133	145	0,077	0,098	0,117	0,135	0,165	0,189	0,210
80	0,043	0,055	0,066	0,076	0,093	0,106	0,118	95	0,068	0,087	0,104	0,120	0,147	0,168	0,187

Die angegebenen Arbeitswerte sind Richtwerte.  
Die für den jeweiligen Bearbeitungsfall optimalen Daten sollten im Versuch oder während der Bearbeitung ermittelt werden.

# Schnittwertempfehlung für Eckfräser

Vorschub und Schnittgeschwindigkeit

Werkzeuflänge/ Korrekturfaktor:	
Länge	$f_z$ & $v_c$
kurz	1
lang	0,9
überlang	0,8
extra lang	0,6

Nutfräsen

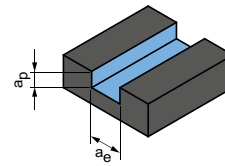

$$a_p = 1xD$$

$$a_e = 1xD$$

## OptiMill-Alu-HPC I M3493

MZG*	Werkstoff	Festigkeit/ Härte [N/mm <sup>2</sup> ] [HRC]	Kühlung			$v_c$ [m/min]	$f_z$ [mm]							
			MMS/Luft	Trocken	KSS		Fräserdurchmesser [mm]							
							2,00	4,00	6,00	8,00	10,00	12,00	16,00	20,00
N1	N1.1 Aluminium, unlegiert und legiert <3 % Si		✓	✓	✓	<b>765</b>	0,021	0,041	0,059	0,075	0,090	0,104	0,127	0,145
	N1.2 Aluminium, legiert ≤ 7 % Si		✓	✓	✓	<b>510</b>	0,023	0,043	0,062	0,079	0,095	0,109	0,133	0,152
	N1.3 Aluminium, legiert > 7-12 % Si		✓	✓	✓	<b>405</b>	0,024	0,045	0,065	0,083	0,099	0,114	0,139	0,159
	N1.4 Aluminium, legiert > 12 % Si		✓	✓	✓	<b>295</b>	0,026	0,049	0,071	0,090	0,108	0,124	0,152	0,174
N2	N2.1 Kupfer, unlegiert und niedriglegiert	< 300	✓	✓	✓	<b>295</b>	0,017	0,033	0,047	0,060	0,072	0,083	0,101	0,116
	N2.2 Kupfer, legiert	> 300	✓	✓	✓	<b>220</b>	0,017	0,033	0,047	0,060	0,072	0,083	0,101	0,116
	N2.3 Messing, Bronze, Rotguss	< 1.200	✓	✓	✓	<b>365</b>	0,011	0,020	0,029	0,038	0,045	0,052	0,063	0,072
N4	N4.1 Kunststoff, Thermoplaste		✓	✓	✓	<b>100</b>	0,011	0,020	0,029	0,038	0,045	0,052	0,063	0,072
	N4.2 Kunststoff, Duroplaste		✓	✓	✓	<b>150</b>	0,011	0,020	0,029	0,038	0,045	0,052	0,063	0,072
	N4.3 Kunststoff, Schaumstoffe		✓	✓		<b>265</b>	0,006	0,012	0,018	0,023	0,027	0,031	0,038	0,043

Teilschnitt

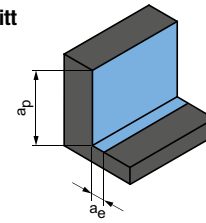

$$a_p = 1,5xD$$

$$a_e = 0,25xD$$

## OptiMill-Alu-HPC-Pocket I M3413

MZG*	Werkstoff	Festigkeit/Härte [N/mm <sup>2</sup> ] [HRC]	Kühlung			$v_c$ [m/min]	$f_z$ [mm]					
			MMS/Luft	Trocken	KSS		Fräserdurchmesser [mm]					
							5,00	8,00	10,00	12,00	16,00	20,00
N1	N1.1 Aluminium, unlegiert und legiert <3 % Si		✓	✓	✓	<b>945</b>	0,080	0,120	0,145	0,169	0,210	0,243
	N1.2 Aluminium, legiert ≤ 7 % Si		✓	✓	✓	<b>625</b>	0,084	0,126	0,152	0,177	0,221	0,256
	N1.3 Aluminium, legiert > 7-12 % Si		✓	✓	✓	<b>500</b>	0,088	0,132	0,160	0,186	0,231	0,268
	N1.4 Aluminium, legiert > 12 % Si		✓	✓	✓	<b>360</b>	0,096	0,144	0,174	0,202	0,252	0,292
N2	N2.1 Kupfer, unlegiert und niedriglegiert	< 300	✓	✓	✓	<b>360</b>	0,064	0,096	0,116	0,135	0,168	0,195
	N2.2 Kupfer, legiert	> 300	✓	✓	✓	<b>270</b>	0,064	0,096	0,116	0,135	0,168	0,195
	N2.3 Messing, Bronze, Rotguss	< 1.200	✓	✓	✓	<b>450</b>	0,040	0,060	0,073	0,084	0,105	0,122
N4	N4.1 Kunststoff, Thermoplaste		✓	✓	✓	<b>125</b>	0,040	0,060	0,073	0,084	0,105	0,122
	N4.2 Kunststoff, Duroplaste		✓	✓	✓	<b>185</b>	0,040	0,060	0,073	0,084	0,105	0,122
	N4.3 Kunststoff, Schaumstoffe		✓	✓		<b>565</b>	0,024	0,036	0,044	0,051	0,063	0,073

\* MILLER Zerspanungsgruppen



**Schruppen**

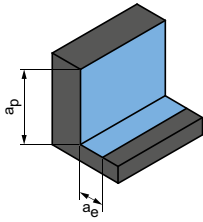

$a_p = 1,5xD$   
 $a_e = 0,25xD$

**Schlichten**

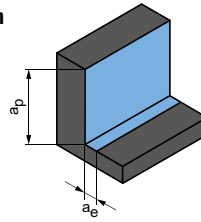

$a_p = 1,5xD$   
 $a_e = 0,1xD$

$v_c$ [m/min]	$f_z$ [mm]								$v_c$ [m/min]	$f_z$ [mm]							
	Fräserdurchmesser [mm]									Fräserdurchmesser [mm]							
	2,00	4,00	6,00	8,00	10,00	12,00	16,00	20,00		2,00	4,00	6,00	8,00	10,00	12,00	16,00	20,00
<b>1.180</b>	0,030	0,057	0,082	0,105	0,126	0,145	0,177	0,202	<b>1.410</b>	0,042	0,080	0,115	0,147	0,176	0,202	0,246	0,282
<b>785</b>	0,032	0,060	0,087	0,111	0,132	0,152	0,186	0,213	<b>940</b>	0,044	0,084	0,120	0,154	0,184	0,212	0,259	0,296
<b>625</b>	0,033	0,063	0,091	0,116	0,139	0,159	0,195	0,223	<b>750</b>	0,046	0,088	0,126	0,161	0,193	0,222	0,271	0,310
<b>450</b>	0,036	0,069	0,099	0,126	0,151	0,174	0,212	0,243	<b>540</b>	0,050	0,096	0,138	0,176	0,211	0,242	0,296	0,338
<b>450</b>	0,024	0,046	0,066	0,084	0,101	0,116	0,142	0,162	<b>540</b>	0,033	0,064	0,092	0,117	0,140	0,161	0,197	0,225
<b>340</b>	0,024	0,046	0,066	0,084	0,101	0,116	0,142	0,162	<b>405</b>	0,033	0,064	0,092	0,117	0,140	0,161	0,197	0,225
<b>565</b>	0,015	0,029	0,041	0,053	0,063	0,072	0,089	0,101	<b>675</b>	0,021	0,040	0,057	0,073	0,088	0,101	0,123	0,141
<b>155</b>	0,015	0,029	0,041	0,053	0,063	0,072	0,089	0,101	<b>185</b>	0,021	0,040	0,057	0,073	0,088	0,101	0,123	0,141
<b>230</b>	0,015	0,029	0,041	0,053	0,063	0,072	0,089	0,101	<b>275</b>	0,021	0,040	0,057	0,073	0,088	0,101	0,123	0,141
<b>405</b>	0,009	0,017	0,025	0,032	0,038	0,043	0,053	0,061	<b>485</b>	0,013	0,024	0,034	0,044	0,053	0,061	0,074	0,085

**Vollschnitt**

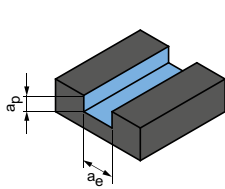

$a_p = 1xD$   
 $a_e = 1xD$

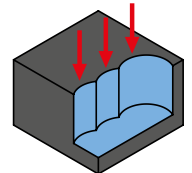
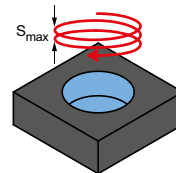
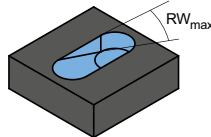

$v_c$ [m/min]	$f_z$ [mm]						Rampen	$S_{max}$	Helixfräsen		Bohren	
	Fräserdurchmesser [mm]								$RW_{max}$	$EW_{max}$		$f_z$ Faktor
	5,00	8,00	10,00	12,00	16,00	20,00						
<b>610</b>	0,047	0,071	0,086	0,099	0,124	0,144	45°	0,75xD	25°	16°	0,8	
<b>405</b>	0,049	0,074	0,090	0,104	0,130	0,151	45°	0,75xD	25°	16°	0,8	
<b>325</b>	0,052	0,078	0,094	0,109	0,136	0,158	45°	0,75xD	25°	16°	0,8	
<b>235</b>	0,057	0,085	0,103	0,119	0,149	0,172	45°	0,75xD	25°	16°	0,8	
<b>235</b>	0,038	0,057	0,068	0,080	0,099	0,115	45°	0,75xD	25°	16°	0,8	
<b>175</b>	0,038	0,057	0,068	0,080	0,099	0,115	45°	0,75xD	25°	16°	0,8	
<b>295</b>	0,024	0,035	0,043	0,050	0,062	0,072	45°	0,75xD	25°	16°	0,8	
<b>80</b>	0,024	0,035	0,043	0,050	0,062	0,072	45°	0,75xD	25°	16°	0,8	
<b>120</b>	0,024	0,035	0,043	0,050	0,062	0,072	45°	0,75xD	25°	16°	0,8	
<b>365</b>	0,014	0,021	0,026	0,030	0,037	0,043	45°	0,75xD	25°	16°	0,8	

**Begriffserklärung:**

- $RW_{max}$  = maximaler Winkel der Rampe
- $S_{max}$  = maximale Steigung der Helix
- G = Verhältnis Kreistaschen-Ø beim Eintauchen zum Werkzeug-Ø  
Bsp: Werkzeug-Ø 12 mm bei G=1,5 ergibt Taschen-Ø von 18 mm
- $EW_{max}$  = Steigungswinkel der Helix (ergibt sich aus G und  $S_{max}$ )

Die angegebenen Arbeitswerte sind Richtwerte.  
Die für den jeweiligen Bearbeitungsfall optimalen Daten sollten im Versuch oder während der Bearbeitung ermittelt werden.

# Schnittwertempfehlung für Eckfräser

Vorschub und Schnittgeschwindigkeit

Teilschnitt

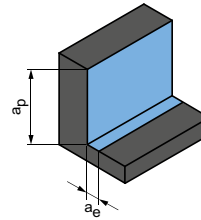

$$a_p = 3xD$$

$$a_e = 0,1xD$$

## OptiMill-Alu-HPC-Pocket I M3414

MZG*	Werkstoff	Festigkeit/ Härte [N/mm <sup>2</sup> ] [HRC]	Kühlung			V <sub>c</sub> [m/min]	f <sub>z</sub> [mm]								
			MMS/Luft	Trocken	KSS		Fräserdurchmesser [mm]								
							5,00	8,00	10,00	12,00	14,00	16,00	18,00	20,00	
N1	N1.1	Aluminium, unlegiert und legiert <3 % Si	✓	✓	✓	915	0,061	0,091	0,110	0,126	0,141	0,154	0,166	0,176	
	N1.2	Aluminium, legiert ≤ 7 % Si	✓	✓	✓	610	0,064	0,096	0,115	0,132	0,148	0,162	0,174	0,185	
	N1.3	Aluminium, legiert > 7-12 % Si	✓	✓	✓	485	0,067	0,101	0,121	0,139	0,155	0,169	0,182	0,193	
	N1.4	Aluminium, legiert > 12 % Si	✓	✓	✓	350	0,073	0,110	0,131	0,151	0,169	0,185	0,199	0,211	
N2	N2.1	Kupfer, unlegiert und niedriglegiert	< 300	✓	✓	✓	350	0,049	0,073	0,088	0,101	0,113	0,123	0,132	0,141
	N2.2	Kupfer, legiert	> 300	✓	✓	✓	265	0,049	0,073	0,088	0,101	0,113	0,123	0,132	0,141
	N2.3	Messing, Bronze, Rotguss	< 1.200	✓	✓	✓	440	0,030	0,046	0,055	0,063	0,070	0,077	0,083	0,088
N4	N4.1	Kunststoff, Thermoplaste	✓	✓	✓	120	0,030	0,046	0,055	0,063	0,070	0,077	0,083	0,088	
	N4.2	Kunststoff, Duroplaste	✓	✓	✓	180	0,030	0,046	0,055	0,063	0,070	0,077	0,083	0,088	
	N4.3	Kunststoff, Schaumstoffe	✓	✓	✓	315	0,018	0,027	0,033	0,038	0,042	0,046	0,050	0,053	

## OptiMill-Alu-HPC-Pocket I M3414

MZG*	Werkstoff	Festigkeit/ Härte [N/mm <sup>2</sup> ] [HRC]	Kühlung		
			MMS/Luft	Trocken	KSS
N1	N1.1	Aluminium, unlegiert und legiert <3 % Si	✓	✓	✓
	N1.2	Aluminium, legiert ≤ 7 % Si	✓	✓	✓
	N1.3	Aluminium, legiert > 7-12 % Si	✓	✓	✓
	N1.4	Aluminium, legiert > 12 % Si	✓	✓	✓
N2	N2.1	Kupfer, unlegiert und niedriglegiert	< 300	✓	✓
	N2.2	Kupfer, legiert	> 300	✓	✓
	N2.3	Messing, Bronze, Rotguss	< 1.200	✓	✓
N4	N4.1	Kunststoff, Thermoplaste	✓	✓	✓
	N4.2	Kunststoff, Duroplaste	✓	✓	✓
	N4.3	Kunststoff, Schaumstoffe	✓	✓	✓

### Berechnungsbeispiel für 42CrMo4 ø 12 mm:

$$f_z \mid a_e \mid h_m \text{ max.} = \frac{D}{100} \cdot \text{Wert siehe Tabelle}$$

N1.1	Aluminium, unlegiert und legiert <3 % Si	✓	✓	✓	915	0,061	0,091	0,110	0,126	0,141	0,154	0,166	0,176
------	--	---	---	---	-----	-------	-------	-------	-------	-------	-------	-------	-------

1  $f_z = \frac{12 \text{ mm}}{100} \cdot 1,2 = 0,144 \text{ mm}$

2  $h_m \text{ max.} = \frac{12 \text{ mm}}{100} \cdot 0,84 = 0,101 \text{ mm}$

\* MILLER Zerspanungsgruppen

**Vollschnitt**

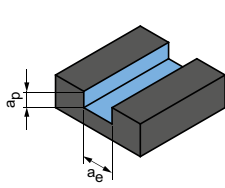

$a_p = 1xD$   
 $a_e = 1xD$

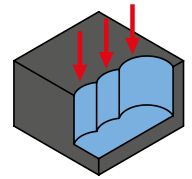
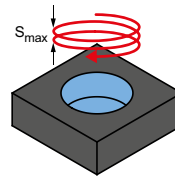
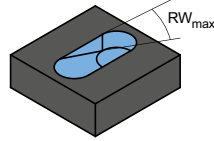

$v_c$ [m/min]	$f_z$ [mm]								Rampen	Helixfräsen		Stechen	
	Fräserdurchmesser [mm]								$RW_{max}$	$S_{max}$	$EW_{max}$		$f_z$ Faktor
	5,00	8,00	10,00	12,00	14,00	16,00	18,00	20,00		$G = 1,5$	$G = 1,8$		
<b>495</b>	0,045	0,068	0,081	0,093	0,104	0,114	0,123	0,130	45°	0,75xD	25°	16°	0,8
<b>330</b>	0,047	0,071	0,085	0,098	0,109	0,120	0,129	0,137	45°	0,75xD	25°	16°	0,8
<b>265</b>	0,050	0,075	0,089	0,103	0,115	0,125	0,135	0,143	45°	0,75xD	25°	16°	0,8
<b>190</b>	0,054	0,081	0,097	0,112	0,125	0,137	0,147	0,156	45°	0,75xD	25°	16°	0,8
<b>190</b>	0,036	0,054	0,065	0,075	0,083	0,091	0,098	0,104	45°	0,75xD	25°	16°	0,8
<b>145</b>	0,036	0,054	0,065	0,075	0,083	0,091	0,098	0,104	45°	0,75xD	25°	16°	0,8
<b>240</b>	0,023	0,034	0,041	0,047	0,052	0,057	0,061	0,065	45°	0,75xD	25°	16°	0,8
<b>65</b>	0,023	0,034	0,041	0,047	0,052	0,057	0,061	0,065	45°	0,75xD	25°	16°	0,8
<b>100</b>	0,023	0,034	0,041	0,047	0,052	0,057	0,061	0,065	45°	0,75xD	25°	16°	0,8
<b>170</b>	0,014	0,020	0,024	0,028	0,031	0,034	0,037	0,039	45°	0,75xD	25°	16°	0,8

**Trochoides Fräsen**

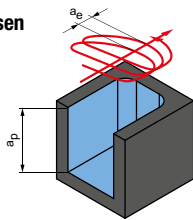

$a_p = 3xD$   
 $a_e = 0,1xD$

**Trochoides Fräsen**

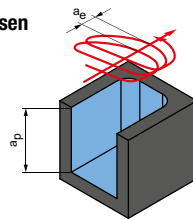

$a_p = 3xD$   
 $a_e = 0,2xD$

$v_c$ [m/min]	$f_z$ [mm] in % vom D	$h_{max}$ [mm] in % vom D	$v_c$ [m/min]	$f_z$ [mm] in % vom D	$h_{max}$ [mm] in % vom D
<b>915</b>	0,1 - 1,4	0,84	<b>810</b>	0,7 - 0,9	1,12
<b>610</b>	0,1 - 1,5	0,90	<b>540</b>	0,7 - 1,0	1,20
<b>485</b>	1,0 - 1,3	0,78	<b>430</b>	0,8 - 1,0	1,04
<b>350</b>	1,1 - 1,5	0,90	<b>310</b>	0,8 - 1,1	1,20
<b>350</b>	0,7 - 1,0	0,60	<b>310</b>	0,5 - 0,8	0,80
<b>265</b>	0,7 - 1,0	0,60	<b>235</b>	0,5 - 0,8	0,80
<b>440</b>	0,4 - 0,6	0,36	<b>390</b>	0,3 - 0,5	0,48
<b>120</b>	0,4 - 0,6	0,36	<b>105</b>	0,3 - 0,5	0,48
<b>180</b>	0,4 - 0,6	0,36	<b>160</b>	0,3 - 0,5	0,48
<b>315</b>	0,3 - 0,4	0,24	<b>280</b>	0,2 - 0,3	0,32

**Begriffserklärung:**

$RW_{max}$  = maximaler Winkel der Rampe

$S_{max}$  = maximale Steigung der Helix

$G$  = Verhältnis Kreistaschen-Ø beim Eintauchen zum Werkzeug-Ø

Bsp: Werkzeug-Ø 12 mm bei  $G=1,5$  ergibt Taschen-Ø von 18 mm

$EW_{max}$  = Steigungswinkel der Helix (ergibt sich aus  $G$  und  $S_{max}$ )

# Schnittwertempfehlung für Eckfräser

Vorschub und Schnittgeschwindigkeit

Werkzeuglänge/ Korrekturfaktor:	
Länge	$f_z$ & $v_c$
kurz	1
lang	0,9

## OptiMill-SPM | M3593, M3591

MZG*	Werkstoff	Festigkeit/Härte [N/mm <sup>2</sup> ] [HRC]	Kühlung		
			MMS/Luft	Trocken	KSS
N N1	N1.1 Aluminium, unlegiert und legiert <3 % Si		✓	✓	✓
	N1.2 Aluminium, legiert ≤ 7 % Si		✓	✓	✓
	N1.3 Aluminium, legiert > 7-12 % Si		✓	✓	✓
	N1.4 Aluminium, legiert > 12 % Si		✓	✓	✓

## OptiMill-Mono-Alu | MN7MA1A

MZG*	Werkstoff	Festigkeit/ Härte [N/mm <sup>2</sup> ] [HRC]	Kühlung			$v_c$ [m/min]	$f_z$ [mm]						
			MMS/Luft	Trocken	KSS		Fräserdurchmesser [mm]						
							2,00	3,00	4,00	5,00	6,00	8,00	12,00
N N1 N2 N4	N1.1 Aluminium, unlegiert und legiert <3 % Si		✓	✓	✓	<b>765</b>	0,043	0,063	0,082	0,100	0,118	0,151	0,207
	N1.2 Aluminium, legiert ≤ 7 % Si		✓	✓	✓	<b>510</b>	0,045	0,066	0,086	0,105	0,124	0,158	0,218
	N1.3 Aluminium, legiert > 7-12 % Si		✓	✓	✓	<b>405</b>	0,047	0,069	0,090	0,110	0,130	0,166	0,228
	N1.4 Aluminium, legiert > 12 % Si		✓	✓	✓	<b>295</b>	0,051	0,075	0,098	0,120	0,141	0,181	0,249
	N2.1 Kupfer, unlegiert und niedriglegiert	< 300	✓	✓	✓	<b>295</b>	0,034	0,050	0,066	0,080	0,094	0,120	0,166
	N2.2 Kupfer, legiert	> 300	✓	✓	✓	<b>220</b>	0,034	0,050	0,066	0,080	0,094	0,120	0,166
	N2.3 Messing, Bronze, Rotguss	< 1.200	✓	✓	✓	<b>365</b>	0,021	0,031	0,041	0,050	0,059	0,075	0,104
	N4.1 Kunststoff, Thermoplaste		✓	✓	✓	<b>100</b>	0,021	0,031	0,041	0,050	0,059	0,075	0,104
	N4.2 Kunststoff, Duroplaste		✓	✓	✓	<b>150</b>	0,021	0,031	0,041	0,050	0,059	0,075	0,104
	N4.3 Kunststoff, Schaumstoffe		✓	✓		<b>265</b>	0,013	0,019	0,025	0,030	0,035	0,045	0,062

**Nutfräsen**

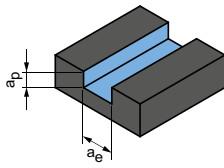

$a_p = 0,5xD$   
 $a_e = 1xD$

**Nutfräsen**

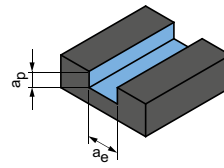

$a_p = 0,3xD$   
 $a_e = 1xD$

$v_c$ [m/min]	$f_z$ [mm]								$v_c$ [m/min]	$f_z$ [mm]							
	Fräserdurchmesser [mm]									Fräserdurchmesser [mm]							
	6,00	8,00	10,00	12,00	16,00	20,00	25,00	32,00		6,00	8,00	10,00	12,00	16,00	20,00	25,00	32,00
<b>1.990</b>	0,111	0,142	0,170	0,196	0,239	0,273	0,305	0,332	<b>1.990</b>	0,128	0,164	0,196	0,225	0,275	0,315	0,351	0,383
<b>1.320</b>	0,117	0,149	0,179	0,206	0,251	0,287	0,320	0,349	<b>1.320</b>	0,135	0,172	0,206	0,237	0,289	0,331	0,369	0,402
<b>1.055</b>	0,122	0,156	0,187	0,215	0,263	0,301	0,336	0,366	<b>1.055</b>	0,141	0,180	0,216	0,248	0,303	0,346	0,387	0,421
<b>760</b>	0,134	0,171	0,204	0,235	0,287	0,328	0,366	0,399	<b>760</b>	0,154	0,197	0,235	0,271	0,331	0,378	0,422	0,459

$v_c$ [m/min]	$f_z$ [mm]								$v_c$ [m/min]	$f_z$ [mm]							
	Fräserdurchmesser [mm]									Fräserdurchmesser [mm]							
	2,00	3,00	4,00	5,00	6,00	8,00	12,00	2,00		3,00	4,00	5,00	6,00	8,00	12,00		
<b>1.180</b>	0,060	0,088	0,115	0,140	0,165	0,211	0,290	<b>1.410</b>	0,084	0,122	0,160	0,195	0,229	0,293	0,403		
<b>785</b>	0,063	0,092	0,120	0,147	0,173	0,221	0,304	<b>940</b>	0,088	0,129	0,168	0,205	0,241	0,308	0,424		
<b>625</b>	0,066	0,097	0,126	0,154	0,181	0,232	0,319	<b>750</b>	0,092	0,135	0,176	0,215	0,252	0,322	0,444		
<b>450</b>	0,072	0,106	0,138	0,168	0,198	0,253	0,348	<b>540</b>	0,100	0,147	0,192	0,234	0,275	0,352	0,484		
<b>450</b>	0,048	0,070	0,092	0,112	0,132	0,168	0,232	<b>540</b>	0,067	0,098	0,128	0,156	0,184	0,234	0,323		
<b>340</b>	0,048	0,070	0,092	0,112	0,132	0,168	0,232	<b>405</b>	0,067	0,098	0,128	0,156	0,184	0,234	0,323		
<b>565</b>	0,030	0,044	0,057	0,070	0,082	0,105	0,145	<b>675</b>	0,042	0,061	0,080	0,098	0,115	0,147	0,202		
<b>155</b>	0,030	0,044	0,057	0,070	0,082	0,105	0,145	<b>185</b>	0,042	0,061	0,080	0,098	0,115	0,147	0,202		
<b>230</b>	0,030	0,044	0,057	0,070	0,082	0,105	0,145	<b>275</b>	0,042	0,061	0,080	0,098	0,115	0,147	0,202		
<b>405</b>	0,018	0,026	0,034	0,042	0,049	0,063	0,087	<b>485</b>	0,025	0,037	0,048	0,059	0,069	0,088	0,121		

Die angegebenen Arbeitswerte sind Richtwerte.  
Die für den jeweiligen Bearbeitungsfall optimalen Daten sollten im Versuch oder während der Bearbeitung ermittelt werden.

# Schnittwertempfehlung für Eckfräser

Vorschub und Schnittgeschwindigkeit

Nutfräsen

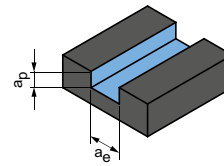

$$a_p = 1 \times D$$

$$a_e = 1 \times D$$

## OptiMill-Composite-Speed-Plus, unbeschichtet | M7248P, M7258P

MZG*	Werkstoff	Festigkeit/ Härte [N/mm <sup>2</sup> ] [HRC]	Kühlung			v <sub>c</sub> [m/min]	f <sub>z</sub> [mm]							
			MMS/Luft	Trocken	KSS		Fräserdurchmesser [mm]							
							4,00	6,00	8,00	10,00	12,00	16,00	20,00	
N N4	N4.1	Kunststoff, Thermoplaste	✓	✓	✓	125								
	N4.2	Kunststoff, Duroplaste	✓	✓	✓		0,020	0,029	0,038	0,045	0,052	0,063	0,072	
	N4.3	Kunststoff, Schaumstoffe	✓	✓										
C C1 C2 C4	C1.1	Kunststoffmatrix, Aramidfaserverstärkt (AFK)	✓	✓	✓	120								
	C1.2	Kunststoffmatrix (duroplastisch), CFK/GFK	✓	✓	✓		0,021	0,026	0,031	0,035	0,038	0,042	0,043	
	C1.3	Kunststoffmatrix (thermoplastisch), CFK/GFK	✓	✓	✓		80	0,021	0,026	0,031	0,035	0,038	0,042	0,043
	C2.1	Kohlenstoffmatrix, Kohlenstofffaserverstärkt (CFC)	✓	✓	✓	120	0,018	0,023	0,027	0,031	0,033	0,037	0,038	
	C4.1	Sandwichkonstruktion, Wabenkern (Honeycomb)	✓	✓		165	0,012	0,015	0,017	0,019	0,021	0,023	0,024	
	C4.2	Sandwichkonstruktion, Schaumkern	✓	✓		125	0,019	0,024	0,028	0,032	0,035	0,039	0,041	

## OptiMill-Composite-Speed-Plus, beschichtet | M7228P, M7238P

MZG*	Werkstoff	Festigkeit/ Härte [N/mm <sup>2</sup> ] [HRC]	Kühlung			v <sub>c</sub> [m/min]	f <sub>z</sub> [mm]							
			MMS/Luft	Trocken	KSS		Fräserdurchmesser [mm]							
							4,00	6,00	8,00	10,00	12,00	16,00	20,00	
C C1 C2 C4	C1.1	Kunststoffmatrix, Aramidfaserverstärkt (AFK)	✓	✓	✓	145								
	C1.2	Kunststoffmatrix (duroplastisch), CFK/GFK	✓	✓	✓		0,021	0,026	0,031	0,035	0,038	0,042	0,043	
	C1.3	Kunststoffmatrix (thermoplastisch), CFK/GFK	✓	✓	✓		100	0,021	0,026	0,031	0,035	0,038	0,042	0,043
	C2.1	Kohlenstoffmatrix, Kohlenstofffaserverstärkt (CFC)	✓	✓	✓	145	0,018	0,023	0,027	0,031	0,033	0,037	0,038	
	C4.1	Sandwichkonstruktion, Wabenkern (Honeycomb)	✓	✓		195	0,012	0,015	0,017	0,019	0,021	0,023	0,024	
	C4.2	Sandwichkonstruktion, Schaumkern	✓	✓		150	0,019	0,024	0,028	0,032	0,035	0,039	0,041	

**Schruppen**

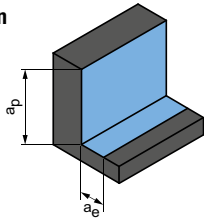

$a_p = 1,5xD$   
 $a_e = 0,25xD$

**Schlichten**

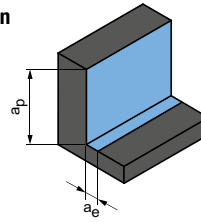

$a_p = 1,5xD$   
 $a_e = 0,1xD$

	$v_c$ [m/min]	$f_z$ [mm]							$v_c$ [m/min]	$f_z$ [mm]						
		Fräserdurchmesser [mm]								Fräserdurchmesser [mm]						
		4,00	6,00	8,00	10,00	12,00	16,00	20,00		4,00	6,00	8,00	10,00	12,00	16,00	20,00
	<b>190</b>	0,029	0,041	0,053	0,063	0,072	0,089	0,101	<b>230</b>	0,040	0,057	0,073	0,088	0,101	0,123	0,141
	<b>200</b>	0,021	0,026	0,031	0,035	0,038	0,042	0,043	<b>295</b>	0,021	0,026	0,031	0,035	0,038	0,042	0,043
	<b>135</b>	0,021	0,026	0,031	0,035	0,038	0,042	0,043	<b>195</b>	0,021	0,026	0,031	0,035	0,038	0,042	0,043
	<b>200</b>	0,018	0,023	0,027	0,031	0,033	0,037	0,038	<b>295</b>	0,018	0,023	0,027	0,031	0,033	0,037	0,038
	<b>270</b>	0,012	0,015	0,017	0,019	0,021	0,023	0,024	<b>395</b>	0,012	0,015	0,017	0,019	0,021	0,023	0,024
	<b>200</b>	0,019	0,024	0,028	0,032	0,035	0,039	0,041	<b>300</b>	0,019	0,024	0,028	0,032	0,035	0,039	0,041

	$v_c$ [m/min]	$f_z$ [mm]							$v_c$ [m/min]	$f_z$ [mm]						
		Fräserdurchmesser [mm]								Fräserdurchmesser [mm]						
		4,00	6,00	8,00	10,00	12,00	16,00	20,00		4,00	6,00	8,00	10,00	12,00	16,00	20,00
	<b>240</b>	0,021	0,026	0,031	0,035	0,038	0,042	0,043	<b>355</b>	0,021	0,026	0,031	0,035	0,038	0,042	0,043
	<b>160</b>	0,021	0,026	0,031	0,035	0,038	0,042	0,043	<b>235</b>	0,021	0,026	0,031	0,035	0,038	0,042	0,043
	<b>240</b>	0,018	0,023	0,027	0,031	0,033	0,037	0,038	<b>355</b>	0,018	0,023	0,027	0,031	0,033	0,037	0,038
	<b>325</b>	0,012	0,015	0,017	0,019	0,021	0,023	0,024	<b>480</b>	0,012	0,015	0,017	0,019	0,021	0,023	0,024
	<b>245</b>	0,019	0,024	0,028	0,032	0,035	0,039	0,041	<b>360</b>	0,019	0,024	0,028	0,032	0,035	0,039	0,041

Die angegebenen Arbeitswerte sind Richtwerte.  
Die für den jeweiligen Bearbeitungsfall optimalen Daten sollten im Versuch oder während der Bearbeitung ermittelt werden.

# Schnittwertempfehlung für Eckfräser

Vorschub und Schnittgeschwindigkeit

## Nutfräsen

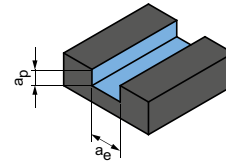

$$a_p = 1 \times D$$

$$a_e = 1 \times D$$

### OptiMill-Composite-Micro | M7901

MZG*	Werkstoff	Festigkeit/ Härte [N/mm <sup>2</sup> ] [HRC]	v <sub>c</sub> [m/min]	f <sub>z</sub> [mm]											
				Fräserdurchmesser [mm]											
				2,00	4,00	6,00	8,00	10,00	12,00	16,00	20,00				
<b>N</b> N4	N4.1	Kunststoff, Thermoplaste													
	N4.2	Kunststoff, Duroplaste	<b>105</b>	0,005	0,008	0,011									
	N4.3	Kunststoff, Schaumstoffe													
<b>C</b>	C1	C1.1	Kunststoffmatrix, Aramidfaserverstärkt (AFK)												
		C1.2	Kunststoffmatrix (duroplastisch), CFK/GFK	<b>105</b>	0,005	0,008	0,011								
		C1.3	Kunststoffmatrix (thermoplastisch), CFK/GFK	<b>70</b>	0,005	0,008	0,011								
	C2	C2.1	Kohlenstoffmatrix, Kohlenstofffaserverstärkt (CFC)	<b>145</b>	0,012	0,018	0,023								
		C4.1	C4.1	Sandwichkonstruktion, Wabenkern (Honeycomb)	<b>195</b>	0,008	0,012	0,015							
			C4.2	Sandwichkonstruktion, Schaumkern	<b>150</b>	0,010	0,019	0,024							

### OptiMill-Composite-Duo | M7222

MZG*	Werkstoff	Festigkeit/ Härte [N/mm <sup>2</sup> ] [HRC]	Kühlung			v <sub>c</sub> [m/min]	f <sub>z</sub> [mm]							
			MMS/Luft	Trocken	Nass		Fräserdurchmesser [mm]							
							2,00	4,00	6,00	8,00	10,00	12,00	16,00	20,00
<b>N</b> N3	N3.1	Graphit				<b>340</b>	0,012	0,022	0,031	0,039	0,048	0,056	0,07	0,081
<b>C</b> C1	C1.2	Kunststoffmatrix (duroplastisch), CFK/GFK	✓	✓	✓	<b>105</b>	0,008	0,013	0,019	0,025	0,03	0,035	0,044	0,051

\* MILLER Zerspanungsgruppen



**Schruppen**

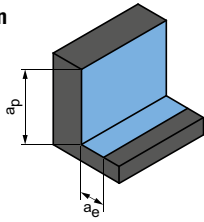

$a_p = 1,5xD$   
 $a_e = 0,25xD$

**Schlichten**

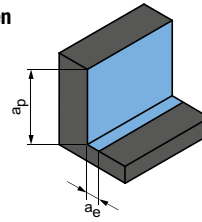

$a_p = 1,5xD$   
 $a_e = 0,1xD$

	$v_c$ [m/min]	$f_z$ [mm]								$v_c$ [m/min]	$f_z$ [mm]							
		Fräserdurchmesser [mm]									Fräserdurchmesser [mm]							
		2,00	4,00	6,00	8,00	10,00	12,00	16,00	20,00		2,00	4,00	6,00	8,00	10,00	12,00	16,00	20,00
	<b>210</b>	0,008	0,013	0,018						<b>310</b>	0,012	0,02	0,028					
	<b>210</b>	0,008	0,013	0,018						<b>310</b>	0,012	0,02	0,028					
	<b>140</b>	0,008	0,013	0,018						<b>210</b>	0,012	0,02	0,028					
	<b>240</b>	0,012	0,018	0,023						<b>355</b>	0,012	0,018	0,023					
	<b>325</b>	0,008	0,012	0,015						<b>480</b>	0,008	0,012	0,015					
	<b>245</b>	0,010	0,019	0,024						<b>360</b>	0,010	0,019	0,024					

	$v_c$ [m/min]	$f_z$ [mm]								$v_c$ [m/min]	$f_z$ [mm]							
		Fräserdurchmesser [mm]									Fräserdurchmesser [mm]							
		2,00	4,00	6,00	8,00	10,00	12,00	16,00	20,00		2,00	4,00	6,00	8,00	10,00	12,00	16,00	20,00
	<b>510</b>	0,021	0,037	0,052	0,067	0,081	0,095	0,118	0,137	<b>680</b>	0,033	0,058	0,082	0,106	0,128	0,149	0,187	0,217
	<b>210</b>	0,013	0,023	0,033	0,042	0,051	0,059	0,074	0,086	<b>310</b>	0,02	0,036	0,051	0,066	0,08	0,093	0,117	0,135

Die angegebenen Arbeitswerte sind Richtwerte.  
 Die für den jeweiligen Bearbeitungsfall optimalen Daten sollten im Versuch oder während der Bearbeitung ermittelt werden.

# Schnittwertempfehlung für Eckfräser

Vorschub und Schnittgeschwindigkeit

## Nutfräsen

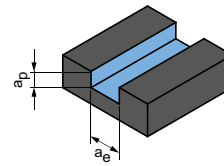

$$a_p = 1xD$$

$$a_e = 1xD$$

### OptiMill-Composite-TwinCut I M7402

MZG*	Werkstoff	Festigkeit/ Härte [N/mm <sup>2</sup> ] [HRC]	v <sub>c</sub> [m/ min]	f <sub>z</sub> [mm]							
				Fräserdurchmesser [mm]							
				2,00	4,00	6,00	8,00	10,00	12,00	16,00	20,00
C	C1.1	Kunststoffmatrix, Aramidfaserverstärkt (AFK)	110	0,015	0,027	0,038	0,049	0,06	0,07	0,087	0,101
	C1.2	Kunststoffmatrix (duroplastisch), CFK/GFK									
	C1.3	Kunststoffmatrix (thermoplastisch), CFK/GFK									

### OptiMill-Thermoplastic-FR I M7644

MZG*	Werkstoff	Festigkeit/ Härte [N/mm <sup>2</sup> ] [HRC]	v <sub>c</sub> [m/ min]	f <sub>z</sub> [mm]							
				Fräserdurchmesser [mm]							
				2,00	4,00	6,00	8,00	10,00	12,00	16,00	20,00
N	N4.1	Kunststoff, Thermoplaste	100	0,011	0,019	0,027	0,035	0,043	0,05	0,062	0,072
	N4.2	Kunststoff, Duroplaste									
	N4.3	Kunststoff, Schaumstoffe									
C	C1.1	Kunststoffmatrix, Aramidfaserverstärkt (AFK)	100	0,011	0,019	0,027	0,035	0,043	0,05	0,062	0,072
	C1.2	Kunststoffmatrix (duroplastisch), CFK/GFK									
	C1.3	Kunststoffmatrix (thermoplastisch), CFK/GFK									

### OptiMill-Mono-Plastic I MN7MP

MZG*	Werkstoff	Festigkeit/ Härte [N/mm <sup>2</sup> ] [HRC]	v <sub>c</sub> [m/ min]	f <sub>z</sub> [mm]							
				Fräserdurchmesser [mm]							
				2,00	4,00	6,00	8,00	10,00	12,00	16,00	20,00
N	N4.1	Kunststoff, Thermoplaste	100	0,022	0,03	0,028	0,047	0,055	0,07	0,085	0,1
	N4.2	Kunststoff, Duroplaste	150	0,022	0,03	0,028	0,047	0,055	0,07	0,085	0,1
	N4.3	Kunststoff, Schaumstoffe									

\* MILLER Zerspanungsgruppen

**Schruppen**

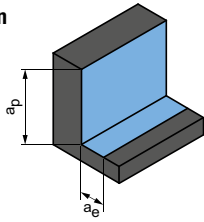

$a_p = 1,5xD$   
 $a_e = 0,25xD$

**Schlichten**

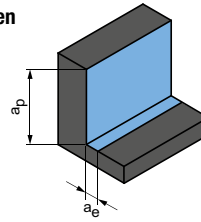

$a_p = 1,5xD$   
 $a_e = 0,1xD$

$v_c$ [m/min]	$f_z$ [mm]								$v_c$ [m/min]	$f_z$ [mm]							
	Fräserdurchmesser [mm]									Fräserdurchmesser [mm]							
	2,00	4,00	6,00	8,00	10,00	12,00	16,00	20,00		2,00	4,00	6,00	8,00	10,00	12,00	16,00	20,00
<b>220</b>	0,026	0,046	0,065	0,084	0,101	0,118	0,148	0,171	<b>325</b>	0,041	0,072	0,103	0,132	0,16	0,187	0,234	0,271

$v_c$ [m/min]	$f_z$ [mm]								$v_c$ [m/min]	$f_z$ [mm]							
	Fräserdurchmesser [mm]									Fräserdurchmesser [mm]							
	2,00	4,00	6,00	8,00	10,00	12,00	16,00	20,00		2,00	4,00	6,00	8,00	10,00	12,00	16,00	20,00
<b>200</b>	0,018	0,033	0,046	0,06	0,072	0,084	0,106	0,122	<b>295</b>	0,029	0,052	0,073	0,094	0,115	0,133	0,167	0,194

$v_c$ [m/min]	$f_z$ [mm]								$v_c$ [m/min]	$f_z$ [mm]							
	Fräserdurchmesser [mm]									Fräserdurchmesser [mm]							
	2,00	4,00	6,00	8,00	10,00	12,00	16,00	20,00		2,00	4,00	6,00	8,00	10,00	12,00	16,00	20,00
<b>200</b>	0,037	0,051	0,065	0,079	0,093	0,119	0,145	0,169	<b>295</b>	0,058	0,081	0,103	0,125	0,147	0,189	0,229	0,267
<b>300</b>	0,037	0,051	0,065	0,079	0,093	0,119	0,145	0,169	<b>445</b>	0,058	0,081	0,103	0,125	0,147	0,189	0,229	0,267

Die angegebenen Arbeitswerte sind Richtwerte.  
 Die für den jeweiligen Bearbeitungsfall optimalen Daten sollten im Versuch oder während der Bearbeitung ermittelt werden.





# ECKFRÄSER – SCHRUPPEN

## Universeller Einsatz

---

OptiMill-Uni-HPC-Rough .....	382
OptiMill-Uni-Wave .....	384
ECU-Mill-Uni-Rough&Finish .....	393

## Nichteisenmetalle

---

OptiMill-SPM-Rough .....	392
--------------------------	-----

## Technischer Anhang

---

Schnittwertempfehlung .....	394
-----------------------------	-----

# OptiMill®-Uni-HPC-Rough

Eckfräser, kurze Ausführung mit Hals  
M3081

**Ausführung:**

Fräserdurchmesser: 5,00 - 20,00 mm

Beschichtung: MF3

Schneidenzahl: 3 bis ø 8 mm

4 ab ø 9 mm

Spiralwinkel: 30°

Besonderheiten: Ungleichteilung,  
Profilhinterschliffene  
HPC-Schrappver-  
zahnung

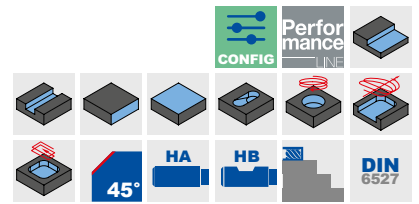
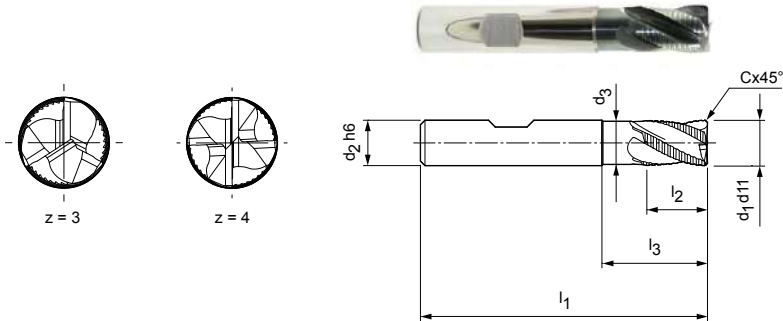

**Lagerhaltige Vorzugsbaureihe**

Baumaße							z	Spezifikation	Bestell-Nr.
d1 d11	d2 h6	d3	l1	l2	l3	Cx45°			
*5,00	6	–	54	8	–	0,30	3	M3081-0500BY	30427454
6,00	6	5,5	54	8	18	0,30	3	M3081-0600BY	30427457
*7,00	8	–	58	11	–	0,30	3	M3081-0700BY	30427458
8,00	8	7,5	58	11	22	0,30	3	M3081-0800BY	30427460
*9,00	10	–	66	13	–	0,50	4	M3081-0900BY	30427461
10,00	10	9,5	66	13	26	0,50	4	M3081-1000BY	30427462
12,00	12	11	73	16	28	0,50	4	M3081-1200BY	30427464
14,00	14	13	76	16	31	0,50	4	M3081-1400BY	30427465
16,00	16	15	82	19	34	0,50	4	M3081-1600BY	30427466
18,00	18	17	84	19	36	0,50	4	M3081-1800BY	30427467
20,00	20	19	92	20	42	0,50	4	M3081-2000BY	30427468

**Konfigurierbare Merkmale**



**Schaftform:**  
Schaftform: HA



**Spezifikation:**  
M3081-1200[Schaftform]Y

Beispiel:  
M3081-1200AY

Schaftform HA

Maßangaben in mm.

\* Ausführung ohne Hals.

Schnittwertempfehlung siehe Kapitelende.

Sonderausführungen und andere Beschichtungen auf Anfrage.

# OptiMill®-Uni-HPC-Rough

Eckfräser, lange Ausführung mit Hals  
M3181

**Ausführung:**  
Fräserdurchmesser: 4,00 - 25,00 mm  
Beschichtung: MF3  
Schneidenzahl: 3 bis ø 8 mm  
4 ab ø 9 mm  
5 ab ø 25 mm  
Spiralwinkel: 30°  
Besonderheiten: Ungleichteilung, Profilhinterschliffene HPC-Schruppverzahnung

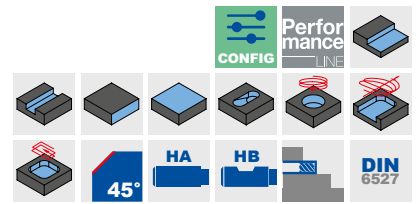
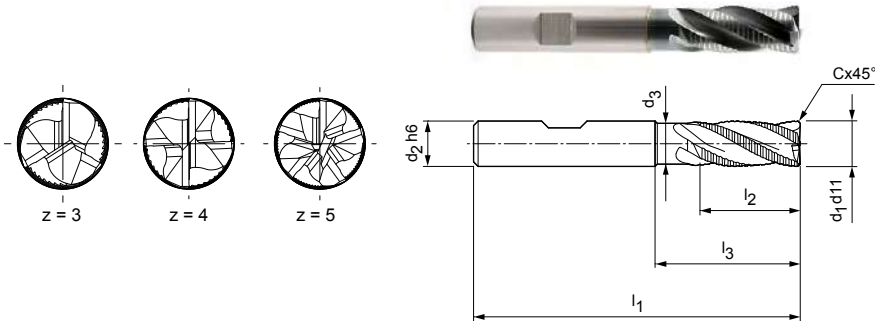

## Lagerhaltige Vorzugsbaureihe

Baumaße							z	Spezifikation	Bestell-Nr.
d <sub>1</sub> d <sub>11</sub>	d <sub>2</sub> h <sub>6</sub>	d <sub>3</sub> h <sub>9</sub>	l <sub>1</sub>	l <sub>2</sub>	l <sub>3</sub>	Cx45°			
*4,00	6	–	57	8	–	0,30	3	M3181-0400BY	30427427
*5,00	6	–	57	13	–	0,30	3	M3181-0500BY	30427428
6,00	6	5,5	57	13	21	0,30	3	M3181-0600BY	30427430
*7,00	8	–	63	16	–	0,30	3	M3181-0700BY	30427432
8,00	8	7,5	63	16	26	0,30	3	M3181-0800BY	30427433
*9,00	10	–	72	19	–	0,50	4	M3181-0900BY	30427434
10,00	10	9,5	72	22	32	0,50	4	M3181-1000BY	30427437
*11,00	12	–	83	26	–	0,50	4	M3181-1100BY	30427438
12,00	12	11	83	26	38	0,50	4	M3181-1200BY	30427439
*13,00	14	–	83	26	–	0,50	4	M3181-1300BY	30427440
14,00	14	13	83	26	42	0,50	4	M3181-1400BY	30427441
16,00	16	15	92	32	44	0,50	4	M3181-1600BY	30427443
18,00	18	17	92	32	48	0,50	4	M3181-1800BY	30427444
20,00	20	19	104	38	54	0,50	4	M3181-2000BY	30427447
25,00	25	24	121	45	65	0,50	5	M3181-2500BY	30427448

## Konfigurierbare Merkmale



**Schaftform:**  
Schaftform: HA



**Spezifikation:**  
M3181-1200[Schaftform]Y

Beispiel:  
M3181-1200AY

Schaftform HA

Maßangaben in mm.

\* Ausführung ohne Hals.

Schnittwertempfehlung siehe Kapitelende.

Sonderausführungen und andere Beschichtungen auf Anfrage.

# OptiMill®-Uni-Wave

Eckfräser, kurze Ausführung  
M3980

**Ausführung:**

Fräserdurchmesser: 4,00 - 25,00 mm  
 Beschichtung: MF2  
 Schneidenzahl: 5  
 Spiralwinkel: ~ 41,5°  
 Besonderheiten: Ungleichteilung, neu entwickeltes Schrupp-profil

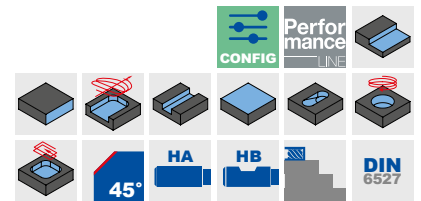
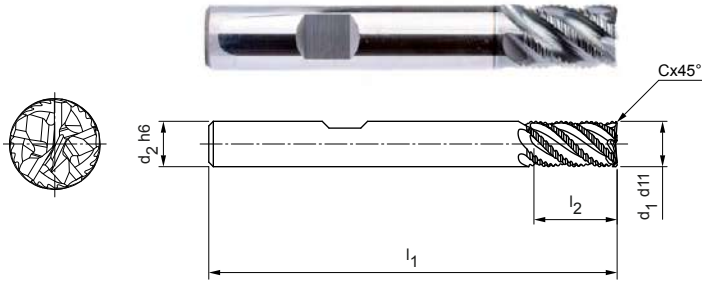

**Lagerhaltige Vorzugsbaureihe**

Baumaße					z	Spezifikation	Bestell-Nr.
d1 d11	d2 h6	l1	l2	Cx45°			
4,00	6	54	8	0,20	5	M3980-0400BL	30866544
5,00	6	54	9	0,25	5	M3980-0500BL	30866545
6,00	6	54	10	0,30	5	M3980-0600BL	30866546
7,00	8	58	11	0,35	5	M3980-0700BL	30866547
8,00	8	58	12	0,40	5	M3980-0800BL	30866548
9,00	10	66	13	0,45	5	M3980-0900BL	30866549
10,00	10	66	14	0,50	5	M3980-1000BL	30866550
12,00	12	73	16	0,60	5	M3980-1200BL	30866551
14,00	14	75	18	0,70	5	M3980-1400BL	30866552
16,00	16	82	22	0,80	5	M3980-1600BL	30866553
20,00	20	92	26	1,00	5	M3980-2000BL	30866555
25,00	25	105	32	1,25	5	M3980-2500BL	30882076

**Auf Anfrage erhältlich**

18,00	18	84	24	0,9	5	M3980-1800BL	30866554
-------	----	----	----	-----	---	--------------	----------

**Konfigurierbare Merkmale**



**Schaftform:**  
Schaftform: HA



**Spezifikation:**  
M3980-1200[Schaftform]L

Beispiel:  
M3980-1200AL

Schaftform HA

Maßangaben in mm.  
 Schnittwertempfehlung siehe Kapitelende.  
 Sonderausführungen und andere Beschichtungen auf Anfrage.



# OptiMill®-Uni-Wave

Eckfräser, lange Ausführung mit Hals  
M3985

**Ausführung:**  
Fräserdurchmesser: 4,00 - 25,00 mm  
Beschichtung: MF2  
Schneidenzahl: 5  
Spiralwinkel: ~ 41,5°  
Besonderheiten: Ungleichteilung, neu entwickeltes Schruppprofil

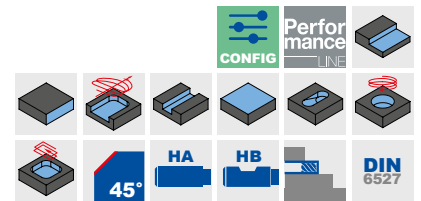
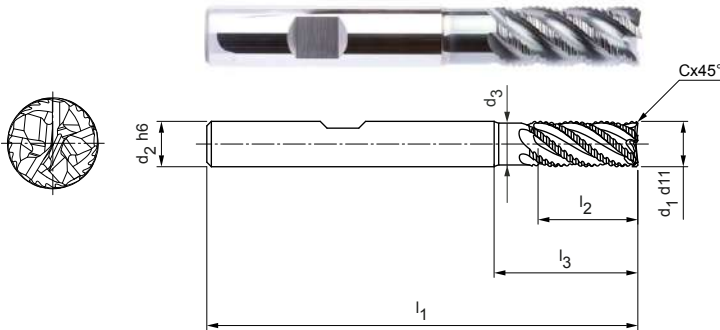

## Lagerhaltige Vorzugsbaureihe

Baumaße							z	Spezifikation	Bestell-Nr.
d1 d11	d2 h6	d3	l1	l2	l3	Cx45°			
4,00	6	3,7	57	11	19	0,20	5	M3985-0400BL	30837662
5,00	6	4,6	57	13	19	0,25	5	M3985-0500BL	30837663
6,00	6	5,6	57	13	19	0,30	5	M3985-0600BL	30837664
7,00	8	6,5	63	16	25	0,35	5	M3985-0700BL	30837665
8,00	8	7,4	63	19	25	0,40	5	M3985-0800BL	30837666
9,00	10	8,3	72	19	30	0,45	5	M3985-0900BL	30837667
10,00	10	9,3	72	22	30	0,50	5	M3985-1000BL	30837668
12,00	12	11,1	83	26	36	0,60	5	M3985-1200BL	30837669
14,00	14	13	83	26	36	0,70	5	M3985-1400BL	30837670
16,00	16	14,8	92	32	42	0,80	5	M3985-1600BL	30837671
20,00	20	18,5	104	38	52	1,00	5	M3985-2000BL	30837673
25,00	25	23,1	125	50	65	1,25	5	M3985-2500BL	30882074

## Auf Anfrage erhältlich

18,00	18	16,7	92	32	42	0,9	5	M3985-1800BL	30837672
-------	----	------	----	----	----	-----	---	--------------	----------

## Konfigurierbare Merkmale



**Schaftform:**  
Schaftform: HA



**Spezifikation:**  
M3985-1200[Schaftform]L

Beispiel:  
M3985-1200AL

Schaftform HA

Maßangaben in mm.  
Schnittwertempfehlung siehe Kapitelende.  
Sonderausführungen und andere Beschichtungen auf Anfrage.

# OptiMill®-Uni-Wave

Eckfräser, lange Ausführung mit Hals, mit innerer Kühlmittelzufuhr  
M3185

**Ausführung:**

Fräserdurchmesser: 4,00 - 20,00 mm  
 Beschichtung: MF2  
 Schneidenzahl: 5  
 Spiralwinkel: ~ 41°  
 Besonderheiten: Ungleichteilung, neu entwickeltes Schrupp-profil

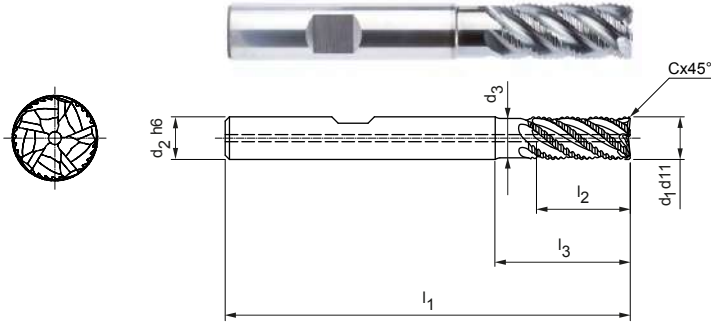

CONFIG Performance LINE

P 1 2 3 4 5 6 M 1 2 3 K 1 2 3 N 1 2 3 4 S 1 2 3 4 5 H 1 2 3

**Lagerhaltige Vorzugsbaureihe**

Baumaße							z	Spezifikation	Bestell-Nr.
d1 d11	d2 h6	d3	l1	l2	l3	Cx45°			
4,00	6	3,7	57	11	19	0,20	5	M3185-0400BL	31102715
5,00	6	4,6	57	13	19	0,25	5	M3185-0500BL	31102716
6,00	6	5,6	57	13	19	0,30	5	M3185-0600BL	31102717
8,00	8	7,4	63	19	25	0,40	5	M3185-0800BL	31102719
10,00	10	9,3	72	22	30	0,50	5	M3185-1000BL	31102731
12,00	12	11,1	83	26	36	0,60	5	M3185-1200BL	31102732
16,00	16	14,8	92	32	42	0,80	5	M3185-1600BL	31102734
20,00	20	18,5	104	38	52	1,00	5	M3185-2000BL	31102735

**Auf Anfrage erhältlich**

14,00	14	13	83	26	36	0,70	5	M3185-1400BL	31102733
-------	----	----	----	----	----	------	---	--------------	----------

**Konfigurierbare Merkmale**

**Schaftform:**  
Schaftform: HA

**Spezifikation:**  
M3185-1200[**Schaftform**]L

Beispiel:  
M3185-1200AL



Maßangaben in mm.  
 Schnittwertempfehlung siehe Kapitelende.  
 Sonderausführungen und andere Beschichtungen auf Anfrage.

# OptiMill®-Uni-Wave

Eckfräser, Ausführung 3xD mit Hals  
M3985-3D

**Ausführung:**  
Fräserdurchmesser: 5,00 - 25,00 mm  
Beschichtung: MF2  
Schneidenzahl: 5  
Spiralwinkel: ~ 42°  
Besonderheiten: Ungleichteilung, neu entwickeltes Schruppprofil

**Anwendung:**  
Zum Eckfräsen bis zu einer maximalen Eingriffsbreite von 0,25xD geeignet. Auch zum trochoiden Fräsen geeignet.

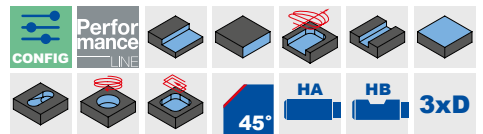
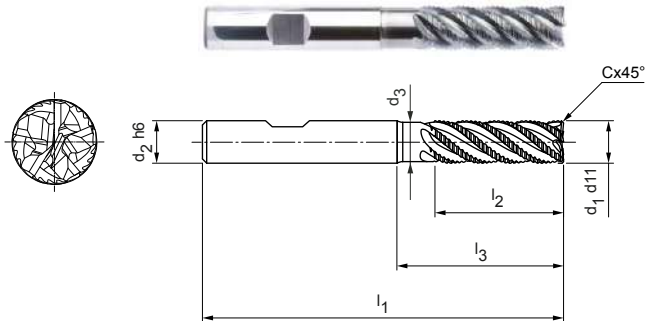

## Lagerhaltige Vorzugsbaureihe

Baumaße							z	Spezifikation	Bestell-Nr.
d <sub>1</sub> d <sub>11</sub>	d <sub>2</sub> h <sub>6</sub>	d <sub>3</sub>	l <sub>1</sub>	l <sub>2</sub>	l <sub>3</sub>	Cx45°			
5,00	6	4,6	62	17	24	0,25	5	M3985-3D-0500BL	30989828
6,00	6	5,6	62	18	25	0,30	5	M3985-3D-0600BL	30989829
8,00	8	7,7	68	24	30	0,40	5	M3985-3D-0800BL	30989840
10,00	10	9,3	80	30	35	0,50	5	M3985-3D-1000BL	30989841
12,00	12	11,1	93	36	45	0,60	5	M3985-3D-1200BL	30989842
14,00	14	13	99	42	50	0,70	5	M3985-3D-1400BL	30989843
16,00	16	14,8	108	48	55	0,80	5	M3985-3D-1600BL	30989844
20,00	20	18,5	126	60	70	1,00	5	M3985-3D-2000BL	30989846

## Auf Anfrage erhältlich

18,00	18	16,7	117	54	67	0,90	5	M3985-3D-1800BL	30989845
25,00	25	21,1	150	75	92	1,25	5	M3985-3D-2500BL	30989848

## Konfigurierbare Merkmale



**Schaftform:**  
Schaftform: HA



**Spezifikation:**  
M3985-3D-1200[**Schaftform**]L

**Beispiel:**  
M3985-3D-1200AL

Schaftform HA

Maßangaben in mm.  
Schnittwertempfehlung siehe Kapitelende.  
Sonderausführungen und andere Beschichtungen auf Anfrage.

# OptiMill®-Uni-Wave

Eckfräser, Ausführung 4xD  
M3985-4D

**Ausführung:**

Fräserdurchmesser:  
Beschichtung:  
Schneidenzahl:  
Spiralwinkel:  
Besonderheiten:

6,00 - 20,00 mm  
MF2  
5  
38°  
Ungleichteilung, neu entwickeltes Schrupp-profil

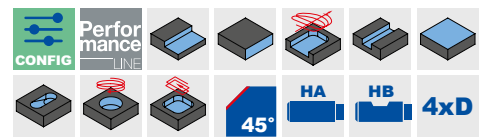
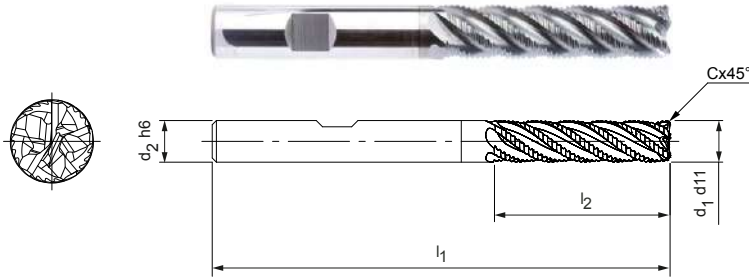

**Lagerhaltige Vorzugsbaureihe**

Baumaße					z	Spezifikation	Bestell-Nr.
d1 d11	d2 h6	l1	l2	Cx45°			
6,00	6	66	24	0,30	5	M3985-4D-0600BL-C0030	31200114
8,00	8	74	32	0,40	5	M3985-4D-0800BL-C0040	31200115
10,00	10	89	40	0,50	5	M3985-4D-1000BL-C0050	31200116
12,00	12	100	48	0,60	5	M3985-4D-1200BL-C0060	31200117
16,00	16	123	64	0,80	5	M3985-4D-1600BL-C0080	31200118
20,00	20	140	80	1,00	5	M3985-4D-2000BL-C0100	31200119

**Konfigurierbare Merkmale**



**Schaftform:**  
Schaftform: HA



**Spezifikation:**  
M3985-4D-1200[**Schaftform**]L-C0060

**Beispiel:**  
M3985-4D-1200AL-C0060

\_\_\_\_\_ Schaftform HA

Maßangaben in mm.  
Schnittwertempfehlung siehe Kapitelende.  
Sonderausführungen und andere Beschichtungen auf Anfrage.

# OptiMill®-Uni-Wave

Eckfräser, Ausführung 5xD  
M3985-5D

**Ausführung:**

Fräserdurchmesser: 6,00 - 20,00 mm  
 Beschichtung: MF2  
 Schneidenzahl: 5  
 Spiralwinkel: 35°  
 Besonderheiten: Ungleichteilung, neu entwickeltes Schrupp-profil

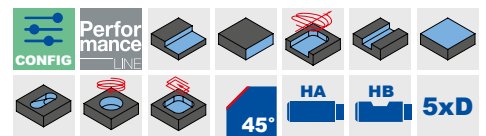
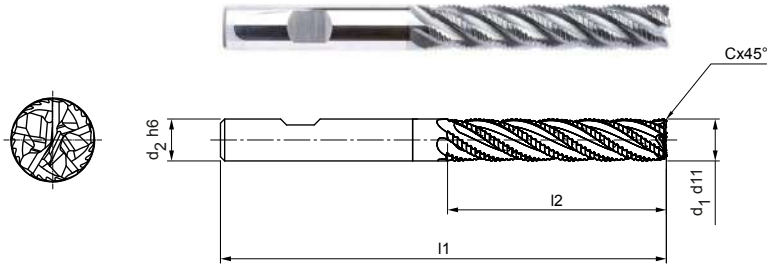

**Lagerhaltige Vorzugsbaureihe**

Baumaße					z	Spezifikation	Bestell-Nr.
d1 d11	d2 h6	l1	l2	Cx45°			
6,00	6	69	30	0,30	5	M3985-5D-0600BL-C0030	31240628
8,00	8	81	40	0,40	5	M3985-5D-0800BL-C0040	31240640
10,00	10	96	50	0,50	5	M3985-5D-1000BL-C0050	31240641
12,00	12	112	60	0,60	5	M3985-5D-1200BL-C0060	31240645
16,00	16	136	80	0,80	5	M3985-5D-1600BL-C0080	31240646
20,00	20	160	100	1,00	5	M3985-5D-2000BL-C0100	31240647

**Konfigurierbare Merkmale**



**Schaftform:**  
Schaftform: HA



**Spezifikation:**  
M3985-5D-1200[**Schaftform**]-L-C0060

**Beispiel:**

M3985-5D-1200AL-C0060

\_\_\_\_\_ Schaftform HA

Maßangaben in mm.  
 Schnittwertempfehlung siehe Kapitelende.  
 Sonderausführungen und andere Beschichtungen auf Anfrage.

# OptiMill®-Uni-Wave

Eckfräser, überlange Ausführung mit Hals  
M3981

**Ausführung:**

Fräserdurchmesser: 5,00 - 25,00 mm  
 Beschichtung: MF2  
 Schneidenzahl: 5  
 Spiralwinkel: ~ 41,5°  
 Besonderheiten: Ungleichteilung, neu entwickeltes Schrupp-profil

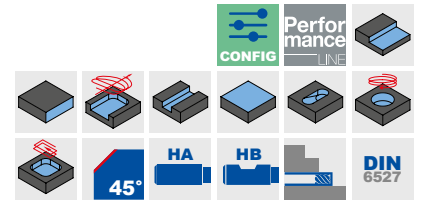
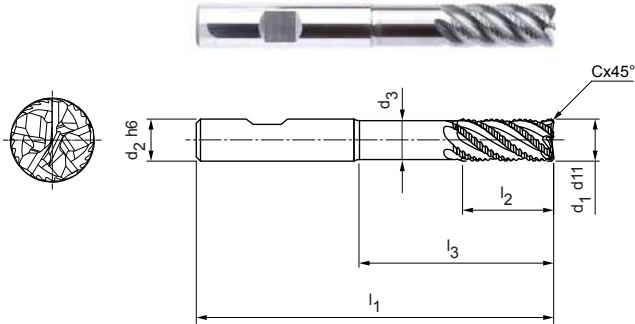

**Lagerhaltige Vorzugsbaureihe**

Baumaße							z	Spezifikation	Bestell-Nr.
d1 d11	d2 h6	d3	l1	l2	l3	Cx45°			
5,00	6	4,6	62	13	24	0,25	5	M3981-0500BL	30990089
6,00	6	5,6	62	13	25	0,30	5	M3981-0600BL	30990120
8,00	8	7,4	68	21	30	0,40	5	M3981-0800BL	30990121
10,00	10	9,3	80	22	38	0,50	5	M3981-1000BL	30990122
12,00	12	11,1	93	26	46	0,60	5	M3981-1200BL	30990123
14,00	14	13	99	26	52	0,70	5	M3981-1400BL	30990124
16,00	16	14,8	108	36	58	0,80	5	M3981-1600BL	30990125
20,00	20	18,5	126	41	74	1,00	5	M3981-2000BL	30990127

**Auf Anfrage erhältlich**

18,00	18	16,7	117	36	67	0,90	5	M3981-1800BL	30990126
25,00	25	23,1	150	50	92	1,25	5	M3981-2500BL	30990128

**Konfigurierbare Merkmale**



**Schaftform:**  
Schaftform: HA



**Spezifikation:**  
M3981-1200[Schaftform]L

Beispiel:  
M3981-1200AL

Schaftform HA

Maßangaben in mm.  
 Schnittwertempfehlung siehe Kapitelende.  
 Sonderausführungen und andere Beschichtungen auf Anfrage.

# OptiMill®-Uni-Wave

Eckfräser, extra lange Ausführung mit Hals  
M3982

**Ausführung:**

Fräserdurchmesser: 6,00 - 20,00 mm  
 Beschichtung: MF2  
 Schneidenzahl: 5  
 Spiralwinkel: ~ 42°  
 Besonderheiten: Ungleichteilung, neu entwickeltes Schruppprofil

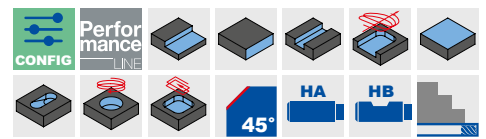
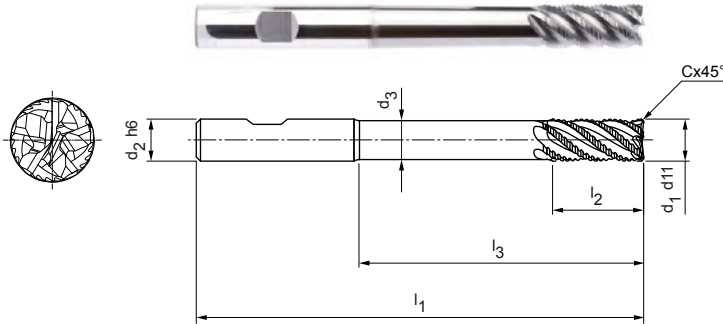

**Lagerhaltige Vorzugsbaureihe**

Baumaße							z	Spezifikation	Bestell-Nr.
d1 d11	d2 h6	d3	l1	l2	l3	Cx45°			
6,00	6	5,4	80	13	42	0,30	5	M3982-0600BL	31096331
8,00	8	7,2	100	21	62	0,40	5	M3982-0800BL	31096333
10,00	10	9	100	22	58	0,50	5	M3982-1000BL	31096335
12,00	12	10,8	120	26	73	0,60	5	M3982-1200BL	31096336
16,00	16	14,4	150	36	100	0,80	5	M3982-1600BL	31096337
20,00	20	18	150	41	98	1,00	5	M3982-2000BL	31096338

**Konfigurierbare Merkmale**



**Schaftform:**  
Schaftform: HA



**Spezifikation:**  
M3982-1200[Schaftform]L

Beispiel:  
M3982-1200AL

Schaftform HA

Maßangaben in mm.  
 Schnittwertempfehlung siehe Kapitelende.  
 Sonderausführungen und andere Beschichtungen auf Anfrage.

# OptiMill®-SPM-Rough

Eckfräser, Ausführung mit innerer Kühlmittelzufuhr  
M3583 | M3581

**Ausführung:**

Fräserdurchmesser: 12,00 - 25,00 mm  
Beschichtung: Unbeschichtet  
Schneidenzahl: 3  
Spiralwinkel: 43°

**Anwendung:**

Hochvolumenzerspanung von Strukturbauteilen aus Aluminium. Für die volle Leistungsfähigkeit des OptiMill-SPM-Rough wird der Einsatz auf Hochleistungsmaschinen ab 50 kW empfohlen.

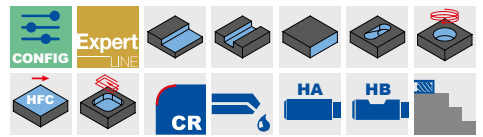
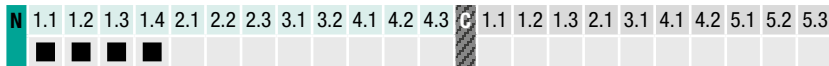
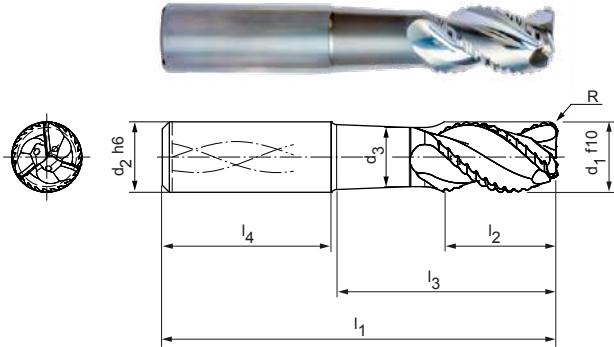

**Metrische Abmessungen | Lagerhaltige Vorzugsbaureihe**

Baumaße								z	Spezifikation	Bestell-Nr.
d <sub>1</sub> f10	d <sub>2</sub> h6	d <sub>3</sub>	l <sub>1</sub>	l <sub>2</sub>	l <sub>3</sub>	l <sub>4</sub>	R			
12,00	12	10	83	18	38	45	2,00	3	M3583-1200AU-R0200	31080108
16,00	16	13,40	92	24	47	45	2,00	3	M3583-1600AU-R0200	31080120
16,00	16	13,40	92	24	47	45	3,00	3	M3583-1600AU-R0300	31080121
20,00	20	16,80	104	35	56	48	2,00	3	M3583-2000AU-R0200	31080123
20,00	20	16,80	104	35	56	48	3,00	3	M3583-2000AU-R0300	31080124
20,00	20	16,80	104	35	56	48	4,00	3	M3583-2000AU-R0400	31080125
25,00	25	21	108	35	52	56	3,00	3	M3583-2500AU-R0300	31080126
25,00	25	21	108	35	52	56	4,00	3	M3583-2500AU-R0400	31080127
25,00	25	21	136	38	80	56	3,00	3	M3581-2500AU-R0300	31080128
25,00	25	21	136	38	80	56	4,00	3	M3581-2500AU-R0400	31080129

**Inch Abmessungen | Auf Anfrage erhältlich**

1/2"	1/2"	0,417"	3 1/2"	3/4"	1 5/8"	1,772"	0,09"	3	M3583-1270AU-R0228	31080109
3/4"	3/4"	0,63"	4 1/8"	1 1/4"	2 1/8"	1,89"	0,12"	3	M3583-1905AU-R0305	31080122
1"	1"	0,839"	5"	1 1/2"	2,783"	2,205"	0,12"	3	M3583-2540AU-R0305	31080130

**Konfigurierbare Merkmale**



**Schaftform:**  
Schaftform: HB



**Spezifikation:**  
M3583-1200[Schaftform]U-R0200

**Beispiel:**  
M3583-1200BU-R0200

Schaftform HB

Maßangaben in mm.  
Schnittwertempfehlung siehe Kapitelende.  
Sonderausführungen und andere Beschichtungen auf Anfrage.



# ECU-Mill-Uni-Rough&Finish

Eckfräser, lange Ausführung  
M3060

**Ausführung:**

Fräserdurchmesser: 6,00 – 20,00 mm  
 Beschichtung: MF3  
 Schneidenzahl: 3 bis ø 8 mm  
 4 ab ø 10 mm  
 Spiralwinkel: 30°

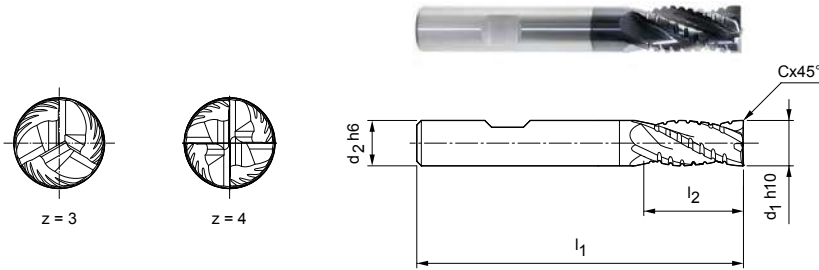

CONFIG Basic LINE

45° 90° HA HB DIN 6527

P 1 2 3 4 5 6 M 1 2 3 K 1 2 3 N 1 2 3 4 S 1 2 3 4 5 H 1 2 3

**Lagerhaltige Vorzugsbaureihe**

Baumaße					z	Spezifikation	Bestell-Nr.
d <sub>1</sub> h10	d <sub>2</sub> h6	l <sub>1</sub>	l <sub>2</sub>	Cx45°			
6,00	6	57	13	–	3	M3060-0600BY	31335646
8,00	8	63	19	0,08	3	M3060-0800BY	31335648
10,00	10	72	22	0,10	4	M3060-1000BY	31335663
12,00	12	83	26	0,12	4	M3060-1200BY	31335665
16,00	16	92	32	0,16	4	M3060-1600BY	31335685
20,00	20	104	38	0,20	4	M3060-2000BY	31335688

**Auf Anfrage erhältlich**

14,00	14	83	26	0,14	4	M3060-1400BY	31335668
18,00	18	92	32	0,18	4	M3060-1800BY	31335687

**Konfigurierbare Merkmale**

**Schaftform:**  
Schaftform: HA

**Spezifikation:**  
M3060-1200[Schaftform]Y

Beispiel:  
M3060-1200AY

Schaftform HA

Maßangaben in mm.  
 Schnittwertempfehlung siehe Kapitelende.  
 Sonderausführungen und andere Beschichtungen auf Anfrage.

# Schnittwertempfehlung für Eckfräser

Vorschub und Schnittgeschwindigkeit

Werkzeuflänge/ Korrekturfaktor:	
Länge	$f_z$ & $v_c$
kurz	1
lang	0,9

## OptiMill-Uni-HPC-Rough | M3081, M3181

MZG*	Werkstoff	Festigkeit/Härte [N/mm <sup>2</sup> ] [HRC]	Kühlung			
			MMS/Luft	Trocken	KSS	
P	P1.1	Bau-, Automaten-, Einsatz- und Vergütungsstähle, unlegiert	< 700	✓	✓	✓
	P1.2	Bau-, Automaten-, Einsatz- und Vergütungsstähle, unlegiert	< 1.200	✓	✓	✓
	P2.1	Nitrier-, Einsatz- und Vergütungsstähle, legiert	< 900	✓	✓	✓
	P2.2	Nitrier-, Einsatz- und Vergütungsstähle, legiert	< 1.400	✓		✓
	P3.1	Werkzeug-, Wälzlager-, Feder- und Schnellarbeitsstähle**	< 800	✓	✓	✓
	P3.2	Werkzeug-, Wälzlager-, Feder- und Schnellarbeitsstähle**	< 1.000	✓		✓
	P3.3	Werkzeug-, Wälzlager-, Feder- und Schnellarbeitsstähle**	< 1.500	✓		✓
	P4.1	Rostfreie Stähle, ferritisch und martensitisch		✓		✓
	P5.1	Stahlguss				✓
	P6.1	Rostfreier Stahlguss, ferritisch und martensitisch				✓
M	M1.1	Rostfreie Stähle, austenitisch	< 700	✓		✓
	M1.2	Rostfreie Stähle, ferritisch/austenitisch (Duplex)	< 1.000			✓
	M2.1	Rostfreier Stahlguss, austenitisch	< 700	✓		✓
	M3.1	Rostfreier Stahlguss, ferritisch/austenitisch (Duplex)	< 1.000			✓
K	K1.1	Gusseisen mit Lamellengraphit (Grauguss), GJL	< 300	✓	✓	✓
	K2.1	Gusseisen mit Kugelgraphit, GJS	< 500	✓	✓	✓
	K2.2	Gusseisen mit Kugelgraphit, GJS	≤ 800	✓	✓	✓
	K2.3	Gusseisen mit Kugelgraphit, GJS	> 800	✓	✓	✓
	K3.1	Gusseisen mit Vermiculargraphit, GJV; Temperguss, GJM	< 500	✓	✓	✓
	K3.2	Gusseisen mit Vermiculargraphit, GJV; Temperguss, GJM	> 500	✓	✓	✓

\* MILLER Zerspanungsgruppen

\*\* Wenn die Legierungsbestandteile Cr, Mo, Ni, V, W in Summe > 8 %, dann die nächst höhere MILLER Zerspanungsgruppe wählen.

**Nutfräsen**

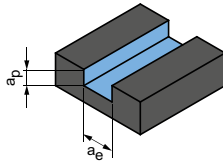

$a_p = 1xD$   
 $a_e = 1xD$

**Schruppen**

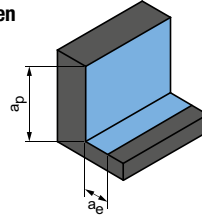

$a_p = 1,5xD$   
 $a_e = 0,25xD$

	$v_c$ [m/min]	$f_z$ [mm]							$v_c$ [m/min]	$f_z$ [mm]						
		Fräserdurchmesser [mm]								Fräserdurchmesser [mm]						
		6,00	8,00	10,00	12,00	16,00	20,00	25,00		6,00	8,00	10,00	12,00	16,00	20,00	25,00
	<b>200</b>	0,035	0,044	0,053	0,061	0,075	0,085	0,095	<b>355</b>	0,059	0,075	0,090	0,103	0,126	0,145	0,161
	<b>165</b>	0,032	0,041	0,050	0,057	0,070	0,080	0,089	<b>290</b>	0,055	0,070	0,084	0,097	0,118	0,135	0,151
	<b>180</b>	0,035	0,044	0,053	0,061	0,075	0,085	0,095	<b>325</b>	0,059	0,075	0,090	0,103	0,126	0,145	0,161
	<b>125</b>	0,029	0,037	0,044	0,051	0,062	0,071	0,079	<b>225</b>	0,049	0,063	0,075	0,086	0,105	0,120	0,134
	<b>120</b>	0,034	0,043	0,051	0,059	0,072	0,082	0,092	<b>210</b>	0,057	0,073	0,087	0,100	0,122	0,140	0,156
	<b>110</b>	0,032	0,041	0,049	0,056	0,068	0,078	0,087	<b>195</b>	0,054	0,069	0,083	0,095	0,116	0,132	0,148
	<b>100</b>	0,030	0,038	0,046	0,053	0,065	0,074	0,082	<b>180</b>	0,051	0,065	0,078	0,090	0,110	0,125	0,140
	<b>80</b>	0,023	0,030	0,035	0,041	0,050	0,057	0,063	<b>145</b>	0,039	0,050	0,060	0,069	0,084	0,096	0,108
	<b>120</b>	0,034	0,043	0,051	0,059	0,072	0,082	0,092	<b>215</b>	0,057	0,073	0,087	0,100	0,122	0,140	0,156
	<b>80</b>	0,016	0,021	0,025	0,028	0,035	0,040	0,044	<b>145</b>	0,027	0,035	0,042	0,048	0,059	0,067	0,075
	<b>55</b>	0,020	0,026	0,031	0,036	0,043	0,050	0,055	<b>110</b>	0,034	0,044	0,053	0,060	0,074	0,084	0,094
	<b>50</b>	0,017	0,021	0,026	0,029	0,036	0,041	0,046	<b>105</b>	0,028	0,036	0,044	0,050	0,061	0,070	0,078
	<b>60</b>	0,022	0,028	0,034	0,039	0,047	0,054	0,060	<b>120</b>	0,037	0,048	0,057	0,066	0,080	0,092	0,102
	<b>55</b>	0,017	0,022	0,027	0,031	0,037	0,043	0,048	<b>110</b>	0,029	0,038	0,045	0,052	0,063	0,072	0,081
	<b>215</b>	0,058	0,074	0,088	0,102	0,124	0,142	0,158	<b>440</b>	0,098	0,125	0,150	0,172	0,211	0,241	0,269
	<b>200</b>	0,049	0,063	0,075	0,086	0,106	0,121	0,135	<b>405</b>	0,083	0,106	0,128	0,147	0,179	0,205	0,228
	<b>160</b>	0,040	0,052	0,062	0,071	0,087	0,099	0,111	<b>330</b>	0,069	0,088	0,105	0,121	0,147	0,169	0,188
	<b>90</b>	0,023	0,030	0,035	0,041	0,050	0,057	0,063	<b>185</b>	0,039	0,050	0,060	0,069	0,084	0,096	0,108
	<b>145</b>	0,040	0,052	0,062	0,071	0,087	0,099	0,111	<b>295</b>	0,069	0,088	0,105	0,121	0,147	0,169	0,188
	<b>135</b>	0,035	0,044	0,053	0,061	0,075	0,085	0,095	<b>275</b>	0,059	0,075	0,090	0,103	0,126	0,145	0,161

Die angegebenen Arbeitswerte sind Richtwerte.

Die für den jeweiligen Bearbeitungsfall optimalen Daten sollten im Versuch oder während der Bearbeitung ermittelt werden.

# Schnittwertempfehlung für Eckfräser

Vorschub und Schnittgeschwindigkeit

## Nutfräsen

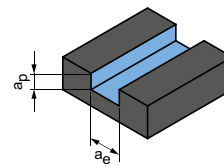

$$a_p = 1xD$$

$$a_e = 1xD$$

OptiMill-Uni-Wave | M3980, M3985, M3185, M3985-3D, M3985-4D, M3985-5D, M3981, M3982

MZG*	Werkstoff	Festigkeit/ Härte [N/mm <sup>2</sup> ] [HRC]	Kühlung			v <sub>c</sub> [m/min]	f <sub>z</sub> [mm]								
			MMS/Luft	Trocken	KSS		Fräserdurchmesser [mm]								
							4,00	6,00	8,00	10,00	12,00	16,00	20,00	25,00	
P	P1.1	Bau-, Automaten-, Einsatz- und Vergütungsstähle, unlegiert	< 700	✓	✓	✓	200	0,027	0,038	0,049	0,058	0,067	0,082	0,094	0,105
	P1.2	Bau-, Automaten-, Einsatz- und Vergütungsstähle, unlegiert	< 1.200	✓	✓	✓	160	0,025	0,036	0,046	0,054	0,063	0,077	0,087	0,098
	P2.1	Nitrier-, Einsatz- und Vergütungsstähle, legiert	< 900	✓	✓	✓	180	0,027	0,038	0,049	0,058	0,067	0,082	0,094	0,105
	P2.2	Nitrier-, Einsatz- und Vergütungsstähle, legiert	< 1.400	✓	✓	✓	125	0,022	0,032	0,041	0,049	0,056	0,068	0,078	0,087
	P3.1	Werkzeug-, Wälzlager-, Feder- und Schnellarbeitsstähle**	< 800	✓	✓	✓	115	0,026	0,037	0,047	0,056	0,065	0,079	0,091	0,101
	P3.2	Werkzeug-, Wälzlager-, Feder- und Schnellarbeitsstähle**	< 1.000	✓	✓	✓	110	0,024	0,035	0,045	0,054	0,062	0,075	0,086	0,096
	P3.3	Werkzeug-, Wälzlager-, Feder- und Schnellarbeitsstähle**	< 1.500	✓	✓	✓	100	0,023	0,033	0,042	0,051	0,058	0,071	0,081	0,091
	P4	P4.1	Rostfreie Stähle, ferritisch und martensitisch		✓	✓	80	0,018	0,025	0,033	0,039	0,045	0,055	0,062	0,07
	P5	P5.1	Stahlguss			✓	120	0,026	0,037	0,047	0,056	0,065	0,079	0,091	0,101
	P6	P6.1	Rostfreier Stahlguss, ferritisch und martensitisch			✓	80	0,012	0,018	0,023	0,027	0,031	0,038	0,044	0,049
M	M1.1	Rostfreie Stähle, austenitisch	< 700	✓	✓	55	0,015	0,022	0,028	0,034	0,039	0,048	0,055	0,061	
	M1.2	Rostfreie Stähle, ferritisch/austenitisch (Duplex)	< 1.000		✓	50	0,013	0,018	0,024	0,028	0,032	0,04	0,045	0,051	
	M2	M2.1	Rostfreier Stahlguss, austenitisch	< 700	✓	✓	60	0,017	0,024	0,031	0,037	0,042	0,052	0,059	0,066
	M3	M3.1	Rostfreier Stahlguss, ferritisch/austenitisch (Duplex)	< 1.000		✓	55	0,013	0,019	0,024	0,029	0,034	0,041	0,047	0,052
K	K1.1	Gusseisen mit Lamellengraphit (Grauguss), GJL	< 300	✓	✓	✓	215	0,044	0,064	0,081	0,097	0,112	0,137	0,156	0,174
	K2.1	Gusseisen mit Kugelgraphit, GJS	< 500	✓	✓	✓	200	0,038	0,054	0,069	0,083	0,095	0,116	0,133	0,148
	K2.2	Gusseisen mit Kugelgraphit, GJS	≤ 800	✓	✓	✓	160	0,031	0,045	0,057	0,068	0,078	0,096	0,109	0,122
	K2.3	Gusseisen mit Kugelgraphit, GJS	> 800	✓	✓	✓	90	0,018	0,025	0,033	0,039	0,045	0,055	0,062	0,07
	K3.1	Gusseisen mit Vermiculargraphit, GJV; Temperguss, GJM	< 500	✓	✓	✓	145	0,031	0,045	0,057	0,068	0,078	0,096	0,109	0,122
	K3.2	Gusseisen mit Vermiculargraphit, GJV; Temperguss, GJM	> 500	✓	✓	✓	135	0,027	0,038	0,049	0,058	0,067	0,082	0,094	0,105

## Korrekturfaktor Werkzeuglänge - k<sub>WL</sub>

Länge	Korrekturfaktoren	
	f <sub>z</sub>	v <sub>c</sub>
kurz / lang / 3xD	1	1
überlang / 4xD	0,9	0,8
extra lang / 5xD	0,7	0,6

### Hinweis:

Für die Ermittlung der Schnittwerte bitte die Hinweise auf den Seiten 520-523 beachten.

### Bitte beachten:

Der Einsatz des M3981 in der Ausführung 3xD wird nur bis zu einer maximalen Eingriffsbreite von 0,25xD empfohlen.

\* MILLER Zerspanungsgruppen

\*\* Wenn die Legierungsbestandteile Cr, Mo, Ni, V, W in Summe > 8 %, dann die nächst höhere MILLER Zerspanungsgruppe wählen.

**Schruppen**

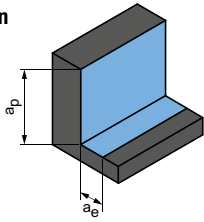

$a_p = 1,5xD$   
 $a_e = 0,25xD$

**Schruppen \*\*\***

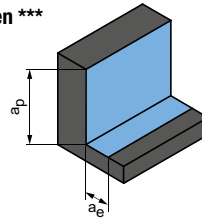

$a_p = 3xD$   
 $a_e = 0,2xD$

\*\*\* Gültig für M3981 - Ausführung 3xD

	$v_c$ [m/min]	$f_z$ [mm]								$v_c$ [m/min]	$f_z$ [mm]							
		Fräserdurchmesser [mm]									Fräserdurchmesser [mm]							
		4,00	6,00	8,00	10,00	12,00	16,00	20,00	25,00		5,00	6,00	8,00	10,00	12,00	16,00	20,00	25,00
	<b>405</b>	0,045	0,065	0,083	0,099	0,114	0,139	0,159	0,177	<b>355</b>	0,054	0,064	0,082	0,098	0,112	0,137	0,157	0,175
	<b>330</b>	0,042	0,06	0,077	0,092	0,106	0,13	0,148	0,166	<b>290</b>	0,051	0,060	0,076	0,091	0,105	0,128	0,146	0,163
	<b>370</b>	0,045	0,065	0,083	0,099	0,114	0,139	0,159	0,177	<b>320</b>	0,054	0,064	0,082	0,098	0,112	0,137	0,157	0,175
	<b>260</b>	0,038	0,054	0,069	0,083	0,095	0,116	0,132	0,148	<b>225</b>	0,045	0,053	0,068	0,081	0,094	0,114	0,131	0,146
	<b>240</b>	0,044	0,063	0,08	0,096	0,11	0,134	0,154	0,171	<b>210</b>	0,053	0,062	0,079	0,094	0,109	0,133	0,152	0,169
	<b>220</b>	0,041	0,059	0,076	0,091	0,104	0,127	0,146	0,163	<b>190</b>	0,050	0,059	0,075	0,090	0,103	0,126	0,144	0,161
	<b>200</b>	0,039	0,056	0,072	0,086	0,099	0,12	0,138	0,154	<b>175</b>	0,047	0,055	0,071	0,085	0,097	0,119	0,136	0,152
	<b>165</b>	0,03	0,043	0,055	0,066	0,076	0,093	0,106	0,118	<b>145</b>	0,036	0,043	0,054	0,065	0,075	0,091	0,105	0,117
	<b>245</b>	0,044	0,063	0,08	0,096	0,11	0,134	0,154	0,171	<b>215</b>	0,053	0,062	0,079	0,094	0,109	0,133	0,152	0,169
	<b>165</b>	0,021	0,03	0,039	0,046	0,053	0,065	0,074	0,083	<b>145</b>	0,025	0,030	0,038	0,046	0,052	0,064	0,073	0,082
	<b>110</b>	0,026	0,038	0,048	0,058	0,066	0,081	0,093	0,103	<b>110</b>	0,032	0,037	0,048	0,057	0,066	0,080	0,092	0,102
	<b>105</b>	0,022	0,031	0,04	0,048	0,055	0,067	0,077	0,086	<b>105</b>	0,026	0,031	0,039	0,047	0,054	0,066	0,076	0,085
	<b>120</b>	0,029	0,041	0,052	0,063	0,072	0,088	0,101	0,112	<b>125</b>	0,034	0,040	0,052	0,062	0,071	0,087	0,099	0,111
	<b>110</b>	0,023	0,032	0,041	0,05	0,057	0,07	0,079	0,089	<b>110</b>	0,027	0,032	0,041	0,049	0,056	0,069	0,078	0,088
	<b>440</b>	0,075	0,108	0,138	0,165	0,19	0,232	0,265	0,296	<b>450</b>	0,091	0,106	0,136	0,163	0,187	0,229	0,262	0,292
	<b>405</b>	0,064	0,092	0,117	0,14	0,161	0,197	0,225	0,251	<b>410</b>	0,077	0,090	0,116	0,138	0,159	0,194	0,222	0,248
	<b>330</b>	0,053	0,076	0,096	0,116	0,133	0,162	0,185	0,207	<b>335</b>	0,063	0,075	0,095	0,114	0,131	0,160	0,183	0,204
	<b>185</b>	0,03	0,043	0,055	0,066	0,076	0,093	0,106	0,118	<b>185</b>	0,036	0,043	0,054	0,065	0,075	0,091	0,105	0,117
	<b>295</b>	0,053	0,076	0,096	0,116	0,133	0,162	0,185	0,207	<b>300</b>	0,063	0,075	0,095	0,114	0,131	0,160	0,183	0,204
	<b>275</b>	0,045	0,065	0,083	0,099	0,114	0,139	0,159	0,177	<b>280</b>	0,054	0,064	0,082	0,098	0,112	0,137	0,157	0,175

Die angegebenen Arbeitswerte sind Richtwerte.

Die für den jeweiligen Bearbeitungsfall optimalen Daten sollten im Versuch oder während der Bearbeitung ermittelt werden.

# Schnittwertempfehlung für Eckfräser

Vorschub und Schnittgeschwindigkeit

## Nutfräsen

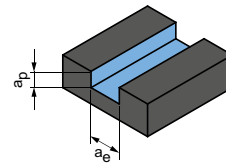

$$a_p = 0,3xD$$

$$a_e = 1xD$$

### OptiMill-SPM-Rough | M3583, M3581

MZG*	Werkstoff	Festigkeit/ Härte [N/mm <sup>2</sup> ] [HRC]	Kühlung			v <sub>c</sub> [m/min]	f <sub>z</sub> [mm]			
			MMS/Luft	Trocken	KSS		Fräserdurchmesser [mm]			
							12,00	16,00	20,00	25,00
<b>N</b> N1	N1.1	Aluminium, unlegiert und legiert <3 % Si	✓	✓	✓	<b>1.530</b>	0,271	0,331	0,378	0,422
	N1.2	Aluminium, legiert ≤ 7 % Si	✓	✓	✓	<b>1.015</b>	0,284	0,347	0,397	0,443
	N1.3	Aluminium, legiert > 7-12 % Si	✓	✓	✓	<b>810</b>	0,298	0,364	0,416	0,464
	N1.4	Aluminium, legiert > 12 % Si	✓	✓	✓	<b>585</b>	0,325	0,397	0,454	0,506

**Nutfräsen**

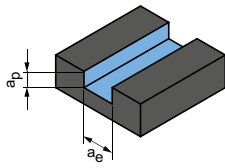

$a_p = 0,5xD$   
 $a_e = 1xD$

**Nutfräsen**

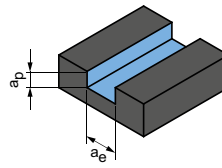

$a_p = 1xD$   
 $a_e = 1xD$

	$V_c$ [m/min]	$f_z$ [mm]				$V_c$ [m/min]	$f_z$ [mm]			
		Fräserdurchmesser [mm]					Fräserdurchmesser [mm]			
		12,00	16,00	20,00	25,00		12,00	16,00	20,00	25,00
	<b>1.530</b>	0,235	0,287	0,328	0,366	<b>1.530</b>	0,186	0,228	0,260	0,291
	<b>1.015</b>	0,247	0,301	0,345	0,384	<b>1.015</b>	0,196	0,239	0,273	0,305
	<b>810</b>	0,258	0,316	0,361	0,403	<b>810</b>	0,205	0,251	0,286	0,320
	<b>585</b>	0,282	0,344	0,394	0,439	<b>585</b>	0,224	0,273	0,313	0,349

Die angegebenen Arbeitswerte sind Richtwerte.

Die für den jeweiligen Bearbeitungsfall optimalen Daten sollten im Versuch oder während der Bearbeitung ermittelt werden.

# Schnittwertempfehlung für Eckfräser

Vorschub und Schnittgeschwindigkeit

Werkzeuglänge/ Korrekturfaktor:	
Länge	$f_z$ & $v_c$
kurz	1
lang	0,9
überlang	0,8
extra lang	0,6

Nutfräsen

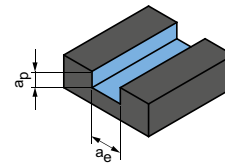

$$a_p = 1 \times D$$

$$a_e = 1 \times D$$

ECU-Mill-Uni-Rough&Finish | M3060

MZG*	Werkstoff	Festigkeit/ Härte [N/mm <sup>2</sup> ] [HRC]	Kühlung			$v_c$ [m/min]	$f_z$ [mm]								
			MMS/Luft	Trocken	KSS		Fräserdurchmesser [mm]								
							6,00	8,00	10,00	12,00	16,00	20,00	25,00		
P	P1.1	Bau-, Automaten-, Einsatz- und Vergütungsstähle, unlegiert	< 700	✓	✓	✓	140	0,028	0,035	0,042	0,049	0,060	0,068	0,076	
	P1.2	Bau-, Automaten-, Einsatz- und Vergütungsstähle, unlegiert	< 1.200	✓	✓	✓	115	0,026	0,033	0,040	0,046	0,056	0,064	0,071	
	P2.1	Nitrier-, Einsatz- und Vergütungsstähle, legiert	< 900	✓	✓	✓	125	0,028	0,035	0,042	0,049	0,060	0,068	0,076	
	P2.2	Nitrier-, Einsatz- und Vergütungsstähle, legiert	< 1.400	✓	✓	✓	90	0,023	0,030	0,035	0,041	0,050	0,057	0,063	
	P3.1	Werkzeug-, Wälzlager-, Feder- und Schnellarbeitsstähle**	< 800	✓	✓	✓	85	0,027	0,034	0,041	0,047	0,058	0,066	0,074	
	P3.2	Werkzeug-, Wälzlager-, Feder- und Schnellarbeitsstähle**	< 1.000	✓	✓	✓	75	0,025	0,033	0,039	0,045	0,055	0,062	0,070	
	P3.3	Werkzeug-, Wälzlager-, Feder- und Schnellarbeitsstähle**	< 1.500	✓	✓	✓	70	0,024	0,031	0,037	0,042	0,052	0,059	0,066	
	P4	P4.1	Rostfreie Stähle, ferritisch und martensitisch		✓	✓	55	0,018	0,024	0,028	0,033	0,040	0,045	0,051	
	P5	P5.1	Stahlguss			✓	85	0,027	0,034	0,041	0,047	0,058	0,066	0,074	
P6	P6.1	Rostfreier Stahlguss, ferritisch und martensitisch			✓	55	0,013	0,017	0,020	0,023	0,028	0,032	0,035		
M	M1.1	Rostfreie Stähle, austenitisch	< 700	✓		✓	40	0,016	0,021	0,025	0,028	0,035	0,040	0,044	
	M1.2	Rostfreie Stähle, ferritisch/austenitisch (Duplex)	< 1.000			✓	35	0,013	0,017	0,021	0,024	0,029	0,033	0,037	
	M2	M2.1	Rostfreier Stahlguss, austenitisch	< 700	✓		✓	40	0,018	0,022	0,027	0,031	0,038	0,043	0,048
	M3	M3.1	Rostfreier Stahlguss, ferritisch/austenitisch (Duplex)	< 1.000			✓	40	0,014	0,018	0,021	0,024	0,030	0,034	0,038
K	K1.1	Gusseisen mit Lamellengraphit (Grauguss), GJL	< 300	✓	✓	✓	150	0,046	0,059	0,071	0,081	0,099	0,114	0,127	
	K2.1	Gusseisen mit Kugelgraphit, GJS	< 500	✓	✓	✓	140	0,039	0,050	0,060	0,069	0,084	0,097	0,108	
	K2.2	Gusseisen mit Kugelgraphit, GJS	500-800	✓	✓	✓	115	0,032	0,041	0,050	0,057	0,070	0,080	0,089	
	K2.3	Gusseisen mit Kugelgraphit, GJS	> 800	✓	✓	✓	65	0,018	0,024	0,028	0,033	0,040	0,045	0,051	
	K3.1	Gusseisen mit Vermiculargraphit, GJV; Temperguss, GJM	< 500	✓	✓	✓	100	0,032	0,041	0,050	0,057	0,070	0,080	0,089	
	K3.2	Gusseisen mit Vermiculargraphit, GJV; Temperguss, GJM	> 500	✓	✓	✓	95	0,028	0,035	0,042	0,049	0,060	0,068	0,076	
N	N1.1	Aluminium, unlegiert und legiert <3 % Si		✓	✓	✓	535	0,047	0,060	0,072	0,083	0,101	0,116	0,129	
	N1.2	Aluminium, legiert <= 7 % Si		✓	✓	✓	355	0,049	0,063	0,076	0,087	0,106	0,122	0,136	
	N1.3	Aluminium, legiert > 7-12 % Si		✓	✓	✓	285	0,052	0,066	0,079	0,091	0,111	0,127	0,142	
	N1.4	Aluminium, legiert > 12 % Si		✓	✓	✓	205	0,057	0,072	0,087	0,099	0,121	0,139	0,155	
	N2.1	Kupfer, unlegiert und niedriglegiert	< 300	✓	✓	✓	205	0,038	0,048	0,058	0,066	0,081	0,093	0,103	
	N2.2	Kupfer, legiert	> 300	✓	✓	✓	155	0,038	0,048	0,058	0,066	0,081	0,093	0,103	
	N2.3	Messing, Bronze, Rotguss	< 1.200	✓	✓	✓	255	0,024	0,030	0,036	0,041	0,051	0,058	0,065	

\* MILLER Zerspanungsgruppen

\*\* Wenn die Legierungsbestandteile Cr, Mo, Ni, V, W in Summe > 8 %, dann die nächst höhere MILLER Zerspanungsgruppe wählen.



**Schruppen**

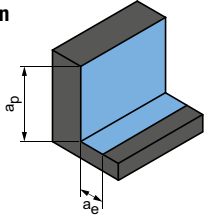

$$a_p = 1,5xD$$

$$a_e = 0,25xD$$

**Schlichten**

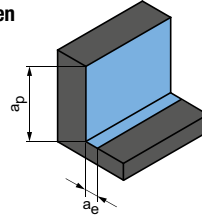

$$a_p = 1,5xD$$

$$a_e = 0,1xD$$

$v_c$ [m/min]	$f_z$ [mm]							$v_c$ [m/min]	$f_z$ [mm]						
	Fräserdurchmesser [mm]								Fräserdurchmesser [mm]						
	6,00	8,00	10,00	12,00	16,00	20,00	25,00		6,00	8,00	10,00	12,00	16,00	20,00	25,00
<b>250</b>	0,047	0,060	0,072	0,083	0,101	0,116	0,129	<b>335</b>	0,074	0,095	0,114	0,131	0,160	0,183	0,204
<b>205</b>	0,044	0,056	0,067	0,077	0,094	0,108	0,120	<b>275</b>	0,069	0,089	0,106	0,122	0,149	0,171	0,190
<b>225</b>	0,047	0,060	0,072	0,083	0,101	0,116	0,129	<b>305</b>	0,074	0,095	0,114	0,131	0,160	0,183	0,204
<b>160</b>	0,039	0,050	0,060	0,069	0,084	0,096	0,108	<b>215</b>	0,062	0,079	0,095	0,109	0,133	0,152	0,170
<b>145</b>	0,045	0,058	0,070	0,080	0,098	0,112	0,125	<b>200</b>	0,072	0,092	0,110	0,127	0,155	0,177	0,197
<b>135</b>	0,043	0,055	0,066	0,076	0,093	0,106	0,118	<b>185</b>	0,068	0,087	0,104	0,120	0,147	0,168	0,187
<b>125</b>	0,041	0,052	0,062	0,072	0,088	0,100	0,112	<b>170</b>	0,064	0,082	0,099	0,113	0,139	0,158	0,177
<b>100</b>	0,031	0,040	0,048	0,055	0,067	0,077	0,086	<b>140</b>	0,050	0,063	0,076	0,087	0,107	0,122	0,136
<b>150</b>	0,045	0,058	0,070	0,080	0,098	0,112	0,125	<b>205</b>	0,072	0,092	0,110	0,127	0,155	0,177	0,197
<b>100</b>	0,022	0,028	0,034	0,039	0,047	0,054	0,060	<b>140</b>	0,035	0,044	0,053	0,061	0,075	0,085	0,095
<b>75</b>	0,027	0,035	0,042	0,048	0,059	0,067	0,075	<b>115</b>	0,043	0,055	0,066	0,076	0,093	0,107	0,119
<b>70</b>	0,023	0,029	0,035	0,040	0,049	0,056	0,062	<b>105</b>	0,036	0,046	0,055	0,063	0,077	0,088	0,099
<b>85</b>	0,030	0,038	0,046	0,052	0,064	0,073	0,082	<b>125</b>	0,047	0,060	0,072	0,083	0,101	0,116	0,129
<b>75</b>	0,024	0,030	0,036	0,041	0,051	0,058	0,065	<b>115</b>	0,037	0,048	0,057	0,065	0,080	0,091	0,102
<b>310</b>	0,078	0,100	0,120	0,138	0,169	0,193	0,215	<b>455</b>	0,124	0,158	0,190	0,218	0,266	0,305	0,340
<b>285</b>	0,067	0,085	0,102	0,117	0,143	0,164	0,183	<b>415</b>	0,105	0,135	0,161	0,185	0,226	0,259	0,289
<b>230</b>	0,055	0,070	0,084	0,097	0,118	0,135	0,151	<b>340</b>	0,087	0,111	0,133	0,153	0,187	0,213	0,238
<b>130</b>	0,031	0,040	0,048	0,055	0,067	0,077	0,086	<b>190</b>	0,050	0,063	0,076	0,087	0,107	0,122	0,136
<b>205</b>	0,055	0,070	0,084	0,097	0,118	0,135	0,151	<b>300</b>	0,087	0,111	0,133	0,153	0,187	0,213	0,238
<b>195</b>	0,047	0,060	0,072	0,083	0,101	0,116	0,129	<b>285</b>	0,074	0,095	0,114	0,131	0,160	0,183	0,204
<b>825</b>	0,066	0,084	0,101	0,116	0,142	0,162	0,181	<b>985</b>	0,092	0,117	0,140	0,161	0,197	0,225	0,252
<b>550</b>	0,069	0,088	0,106	0,122	0,149	0,170	0,190	<b>655</b>	0,096	0,123	0,147	0,169	0,207	0,237	0,264
<b>440</b>	0,073	0,093	0,111	0,128	0,156	0,178	0,199	<b>525</b>	0,101	0,129	0,154	0,178	0,217	0,248	0,277
<b>315</b>	0,079	0,101	0,121	0,139	0,170	0,194	0,217	<b>380</b>	0,110	0,141	0,168	0,194	0,237	0,270	0,302
<b>315</b>	0,053	0,067	0,081	0,093	0,113	0,130	0,145	<b>380</b>	0,073	0,094	0,112	0,129	0,158	0,180	0,201
<b>235</b>	0,053	0,067	0,081	0,093	0,113	0,130	0,145	<b>285</b>	0,073	0,094	0,112	0,129	0,158	0,180	0,201
<b>395</b>	0,033	0,042	0,050	0,058	0,071	0,081	0,090	<b>470</b>	0,046	0,059	0,070	0,081	0,099	0,113	0,126

Die angegebenen Arbeitswerte sind Richtwerte.  
Die für den jeweiligen Bearbeitungsfall optimalen Daten sollten im Versuch oder während der Bearbeitung ermittelt werden.





# ECKFRÄSER – SCHLICHTEN

## Universeller Einsatz

---

OptiMill-Uni-HPC-Finish ..... 404

## Gehärteter Stahl

---

OptiMill-Hardened-Finish ..... 409

## Nichteisenmetalle

---

OptiMill-SPM-Finish ..... 414

## Technischer Anhang

---

Schnittwertempfehlung ..... 416

# OptiMill®-Uni-HPC-Finish

Eckfräser, Ausführung 2xD  
M3917-2D

## Ausführung:

Fräserdurchmesser: 4,00 - 20,00 mm  
Beschichtung: MF3  
Schneidenzahl: 7  
Spiralwinkel: 45°  
Besonderheiten: Ungleichteilung

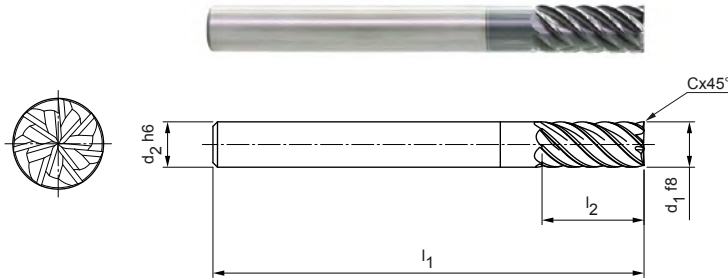

## Lagerhaltige Vorzugsbaureihe

Baumaße					z	Spezifikation	Bestell-Nr.
d <sub>1</sub> f8	d <sub>2</sub> h6	l <sub>1</sub>	l <sub>2</sub>	Cx45°			
4,00	6	57	11	0,04	7	M3917-2D-0400AY-C0004	30887629
5,00	6	57	13	0,05	7	M3917-2D-0500AY-C0005	30887631
6,00	6	57	13	0,06	7	M3917-2D-0600AY-C0006	30887632
8,00	8	63	19	0,08	7	M3917-2D-0800AY-C0008	30887633
10,00	10	72	22	0,10	7	M3917-2D-1000AY-C0010	30887634
12,00	12	83	26	0,12	7	M3917-2D-1200AY-C0012	30887635
14,00	14	83	26	0,14	7	M3917-2D-1400AY-C0014	30887636
16,00	16	92	32	0,16	7	M3917-2D-1600AY-C0016	30887637
20,00	20	104	41	0,20	7	M3917-2D-2000AY-C0020	30887639

## Auf Anfrage erhältlich

18,00	18	92	32	0,18	7	M3917-2D-1800AY-C0018	30887638
-------	----	----	----	------	---	-----------------------	----------

## Konfigurierbare Merkmale



**Schaftform:**  
Schaftform: HB



**Spezifikation:**  
M3917-2D-1200[**Schaftform**]-C0012

## Beispiel:

M3917-2D-1200**BY**-C0012

Schaftform **HB**

Maßangaben in mm.

Schnittwertempfehlung siehe Kapitelende.

Sonderausführungen und andere Beschichtungen auf Anfrage.

# OptiMill®-Uni-HPC-Finish

Eckfräser, Ausführung 3xD  
M3917-3D

**Ausführung:**  
Fräserdurchmesser: 4,00 - 20,00 mm  
Beschichtung: MF3  
Schneidenzahl: 7  
Spiralwinkel: ~ 45°  
Besonderheiten: Ungleichteilung

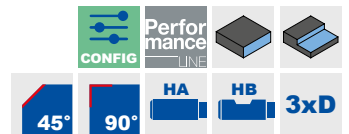
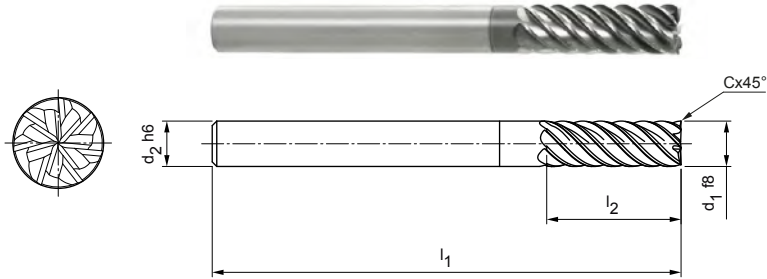

## Ausführung mit Fase | Lagerhaltige Vorzugsbaureihe

Baumaße					z	Spezifikation	Bestell-Nr.
d <sub>1</sub> f8	d <sub>2</sub> h6	l <sub>1</sub>	l <sub>2</sub>	Cx45°			
4,00	6	62	16	0,04	7	M3917-3D-0400AY-C0004	30887641
5,00	6	62	17	0,05	7	M3917-3D-0500AY-C0005	30887642
6,00	6	62	18	0,06	7	M3917-3D-0600AY-C0006	30887643
8,00	8	68	24	0,08	7	M3917-3D-0800AY-C0008	30887644
10,00	10	80	30	0,10	7	M3917-3D-1000AY-C0010	30887645
12,00	12	93	36	0,12	7	M3917-3D-1200AY-C0012	30887646
14,00	14	99	42	0,14	7	M3917-3D-1400AY-C0014	30887647
16,00	16	108	48	0,16	7	M3917-3D-1600AY-C0016	30887648
20,00	20	126	60	0,20	7	M3917-3D-2000AY-C0020	30887650

## Ausführung mit Fase | Auf Anfrage erhältlich

18,00	18	117	54	0,18	7	M3917-3D-1800AY-C0018	30887649
-------	----	-----	----	------	---	-----------------------	----------

## Ausführung mit scharfer Kante | Lagerhaltige Vorzugsbaureihe

4,00	6	62	16	–	7	M3917-3D-0400AY	30982857
5,00	6	62	17	–	7	M3917-3D-0500AY	30982858
6,00	6	62	18	–	7	M3917-3D-0600AY	30982859
8,00	8	68	24	–	7	M3917-3D-0800AY	30982870
10,00	10	80	30	–	7	M3917-3D-1000AY	30982871
12,00	12	93	36	–	7	M3917-3D-1200AY	30982872
14,00	14	99	42	–	7	M3917-3D-1400AY	30982873
16,00	16	108	48	–	7	M3917-3D-1600AY	30982874
20,00	20	126	60	–	7	M3917-3D-2000AY	30982876

## Ausführung mit scharfer Kante | Auf Anfrage erhältlich

18,00	18	117	54	–	7	M3917-3D-1800AY	30982875
-------	----	-----	----	---	---	-----------------	----------

## Konfigurierbare Merkmale

**Schaftform:**  
Schaftform: HB

**Spezifikation:**  
M3917-3D-1200[Schaftform]Y-C0012

**Beispiel:**  
M3917-3D-1200BY-C0012

Schaftform HB

Maßangaben in mm.  
Schnittwertempfehlung siehe Kapitelende.  
Sonderausführungen und andere Beschichtungen auf Anfrage.

# OptiMill®-Uni-HPC-Finish

Eckfräser, Ausführung 4xD  
M3917-4D

## Ausführung:

Fräserdurchmesser: 6,00 - 25,00 mm  
Beschichtung: MF3  
Schneidenzahl: 7  
Spiralwinkel: 45°  
Besonderheiten: Ungleichteilung

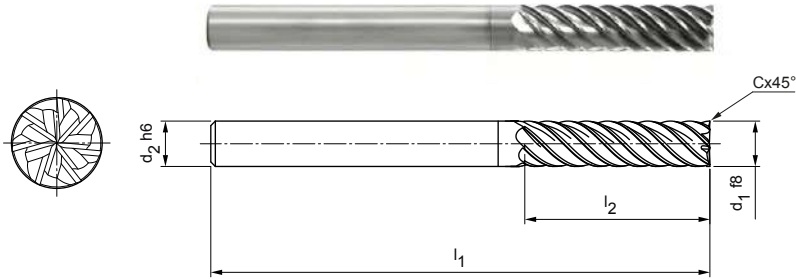

## Lagerhaltige Vorzugsbaureihe

Baumaße					z	Spezifikation	Bestell-Nr.
d <sub>1</sub> f8	d <sub>2</sub> h6	l <sub>1</sub>	l <sub>2</sub>	Cx45°			
6,00	6	66	24	0,06	7	M3917-4D-0600AY-C0006	30887652
8,00	8	74	32	0,08	7	M3917-4D-0800AY-C0008	30887653
10,00	10	89	40	0,10	7	M3917-4D-1000AY-C0010	30887654
12,00	12	100	48	0,12	7	M3917-4D-1200AY-C0012	30887655
14,00	14	108	56	0,14	7	M3917-4D-1400AY-C0014	30887656
16,00	16	123	64	0,16	7	M3917-4D-1600AY-C0016	30887657
20,00	20	140	80	0,20	7	M3917-4D-2000AY-C0020	30887659

## Auf Anfrage erhältlich

18,00	18	130	72	0,18	7	M3917-4D-1800AY-C0018	30887658
25,00	25	170	100	0,25	7	M3917-4D-2500AY-C0025	30887660

## Konfigurierbare Merkmale



**Schaftform:**  
Schaftform: HB



**Spezifikation:**  
M3917-4D-1200[**Schaftform**]-C0012

### Beispiel:

M3917-4D-1200**BY**-C0012

Schaftform HB

Maßangaben in mm.

Schnittwertempfehlung siehe Kapitelende.

Sonderausführungen und andere Beschichtungen auf Anfrage.

# OptiMill®-Uni-HPC-Finish

Eckfräser, Ausführung 5xD  
M3917-5D

## Ausführung:

Fräserdurchmesser: 8,00 - 25,00 mm  
Beschichtung: MF3  
Schneidenzahl: 7  
Spiralwinkel: ~ 45°  
Besonderheiten: Ungleichteilung

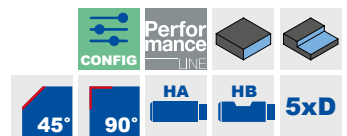
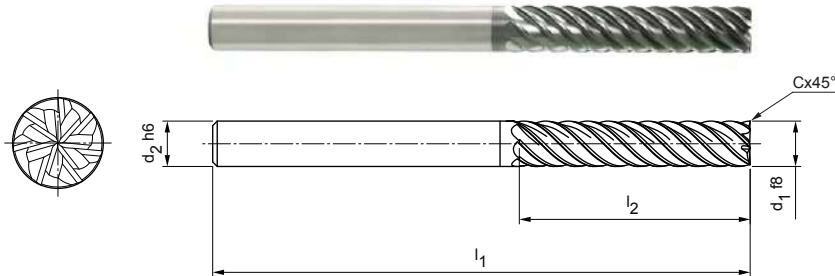

### Ausführung mit Fase | Lagerhaltige Vorzugsbaureihe

Baumaße					z	Spezifikation	Bestell-Nr.
d <sub>1</sub> f8	d <sub>2</sub> h6	l <sub>1</sub>	l <sub>2</sub>	Cx45°			
8,00	8	81	40	0,08	7	M3917-5D-0800AY-C0008	30887661
10,00	10	96	50	0,10	7	M3917-5D-1000AY-C0010	30887662
12,00	12	112	60	0,12	7	M3917-5D-1200AY-C0012	30887663
14,00	14	122	70	0,14	7	M3917-5D-1400AY-C0014	30887664
16,00	16	136	80	0,16	7	M3917-5D-1600AY-C0016	30887665
20,00	20	160	100	0,20	7	M3917-5D-2000AY-C0020	30887667

### Ausführung mit Fase | Auf Anfrage erhältlich

18,00	18	147	90	0,18	7	M3917-5D-1800AY-C0018	30887666
25,00	25	195	125	0,25	7	M3917-5D-2500AY-C0025	30887668

### Kantenausführung mit scharfer Kante | Lagerhaltige Vorzugsbaureihe

8,00	8	81	40	–	7	M3917-5D-0800AY	30982878
10,00	10	96	50	–	7	M3917-5D-1000AY	30982879
12,00	12	112	60	–	7	M3917-5D-1200AY	30982880
14,00	14	122	70	–	7	M3917-5D-1400AY	30982881
16,00	16	136	80	–	7	M3917-5D-1600AY	30982882
20,00	20	160	100	–	7	M3917-5D-2000AY	30982884

### Ausführung mit scharfer Kante | Auf Anfrage erhältlich

18,00	18	147	90	–	7	M3917-5D-1800AY	30982883
25,00	25	195	125	–	7	M3917-5D-2500AY	30982885

### Konfigurierbare Merkmale



**Schafform:**  
Schafform: HB



#### Spezifikation:

M3917-5D-1200[Schafform]Y-C0012

#### Beispiel:

M3917-5D-1200BY-C0012

Schafform HB

Maßangaben in mm.  
Schnittwertempfehlung siehe Kapitelende.  
Sonderausführungen und andere Beschichtungen auf Anfrage.

# OptiMill®-Uni-HPC-Finish

Eckfräser, lange Ausführung mit Hals  
M3096

**Ausführung:**

Fräserdurchmesser: 6,00 - 20,00 mm  
 Beschichtung: MF3  
 Schneidenzahl: 6  
 Spiralwinkel: 39°/41°  
 Besonderheiten: Ungleichteilung

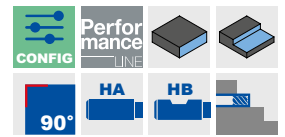
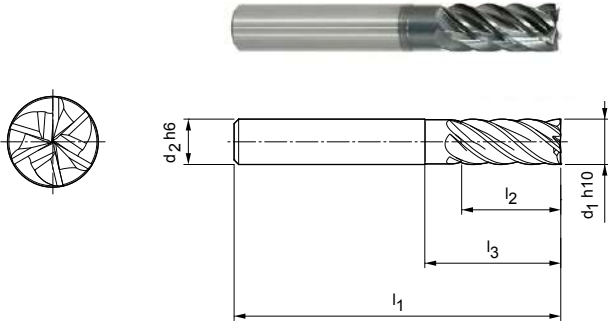

**Lagerhaltige Vorzugsbaureihe**

Baumaße					z	Spezifikation	Bestell-Nr.
d <sub>1</sub> h10	d <sub>2</sub> h6	l <sub>1</sub>	l <sub>2</sub>	l <sub>3</sub>			
6,00	6	57	15	20	6	M3096-0600AY	30270000
8,00	8	63	21	25	6	M3096-0800AY	30270002
10,00	10	72	22	30	6	M3096-1000AY	30270003
12,00	12	83	26	36	6	M3096-1200AY	30270004
16,00	16	92	36	42	6	M3096-1600AY	30270005
20,00	20	104	41	55	6	M3096-2000AY	30270006

**Konfigurierbare Merkmale**



**Schaftform:**  
Schaftform: HB



**Spezifikation:**  
M3096-1200[Schaftform]Y

Beispiel:  
M3096-1200BY

Schaftform HB

Maßangaben in mm.  
 Schnittwertempfehlung siehe Kapitelende.  
 Sonderausführungen und andere Beschichtungen auf Anfrage.



# OptiMill®-Hardened-Finish

Eckfräser, Ausführung 2xD  
M3276-2D

**Ausführung:**  
Fräserdurchmesser: 4,00 - 25,00 mm  
Beschichtung: MFS  
Schneidenzahl: 6  
Spiralwinkel: 55°

**Anwendung:**  
Zum Schlichten von Bauteilen mit einer Härte ab 45 HRC.

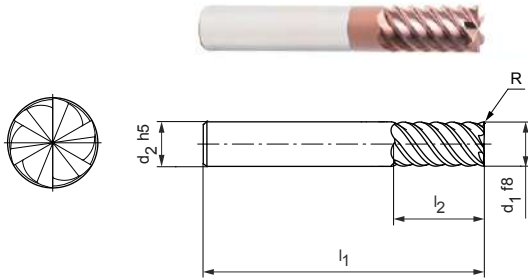

P
1
2
3
4
5
6
M
1
2
3
K
1
2
3
N
1
2
3
4
S
1
2
3
4
5
H
1
2
3

CR

90°

HA

HB

2xD

**Ausführung mit scharfer Kante | Lagerhaltige Vorzugsbaureihe**

Baumaße					z	Spezifikation	Bestell-Nr.
d1 f8	d2 h5	l1	l2	R			
4,00	6	57	11	–	6	M3276-2D-0400A08	31154866
5,00	6	57	13	–	6	M3276-2D-0500A08	31154867
6,00	6	57	13	–	6	M3276-2D-0600A08	31154868
8,00	8	63	19	–	6	M3276-2D-0800A08	31154869
10,00	10	72	22	–	6	M3276-2D-1000A08	31154870
12,00	12	83	26	–	6	M3276-2D-1200A08	31154871
16,00	16	92	32	–	6	M3276-2D-1600A08	31154873

**Ausführung mit scharfer Kante | Auf Anfrage erhältlich**

20,00	20	104	41	–	6	M3276-2D-2000A08	31154875
25,00	25	125	50	–	6	M3276-2D-2500A08	31154876

**Ausführung mit Eckenradius | Lagerhaltige Vorzugsbaureihe**

4,00	6	57	11	0,5	6	M3276-2D-0400A08-R0050	31199152
5,00	6	57	13	0,5	6	M3276-2D-0500A08-R0050	31199153
5,00	6	57	13	1	6	M3276-2D-0500A08-R0100	31199154
6,00	6	57	13	0,5	6	M3276-2D-0600A08-R0050	31199155
6,00	6	57	13	1	6	M3276-2D-0600A08-R0100	31199156
8,00	8	63	19	0,5	6	M3276-2D-0800A08-R0050	31199157
8,00	8	63	19	1	6	M3276-2D-0800A08-R0100	31199158
10,00	10	72	22	0,5	6	M3276-2D-1000A08-R0050	31199159
10,00	10	72	22	1	6	M3276-2D-1000A08-R0100	31199160
12,00	12	83	26	0,5	6	M3276-2D-1200A08-R0050	31199161
12,00	12	83	26	1	6	M3276-2D-1200A08-R0100	31199162
16,00	16	92	32	0,5	6	M3276-2D-1600A08-R0050	31199163
16,00	16	92	32	1	6	M3276-2D-1600A08-R0100	31199164
16,00	16	92	32	2	6	M3276-2D-1600A08-R0200	31199165

**Ausführung mit Eckenradius | Auf Anfrage erhältlich**

20,00	20	104	41	1	6	M3276-2D-2000A08-R0100	31199166
25,00	20	104	41	2	6	M3276-2D-2000A08-R0200	31199167

**Konfigurierbare Merkmale**

**Schaftform:**  
Schaftform: HB

**Spezifikation:**

M3276-2D-1200[Schaftform]08

**Beispiel:**

M3276-2D-1200**B**08

Schaftform HB

# OptiMill®-Hardened-Finish

Eckfräser, Ausführung 3xD  
M3276-3D

**Ausführung:**  
Fräserdurchmesser: 4,00 - 25,00 mm  
Beschichtung: MFS  
Schneidenzahl: 6  
Spiralwinkel: 55°

**Anwendung:**  
Zum Schlichten von Bauteilen mit einer Härte ab 45 HRC.

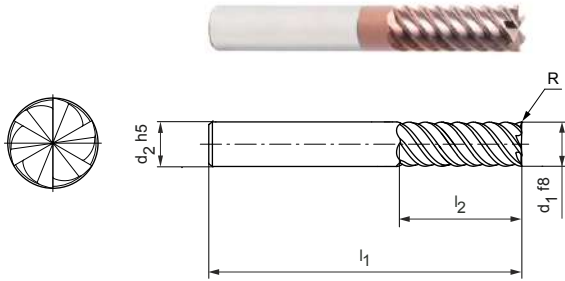

P
1
2
3
4
5
6
M
1
2
3
K
1
2
3
N
1
2
3
4
S
1
2
3
4
5
H
1
2
3

CR

90°

HA

HB

3xD

**Ausführung mit scharfer Kante | Lagerhaltige Vorzugsbaureihe**

Baumaße					z	Spezifikation	Bestell-Nr.
d1 f8	d2 h5	l1	l2	R			
4,00	6	62	16	–	6	M3276-3D-0400A08	31154877
5,00	6	62	17	–	6	M3276-3D-0500A08	31154878
6,00	6	62	18	–	6	M3276-3D-0600A08	31154879
8,00	8	68	24	–	6	M3276-3D-0800A08	31154880
10,00	10	80	30	–	6	M3276-3D-1000A08	31154881
12,00	12	93	36	–	6	M3276-3D-1200A08	31154882
16,00	16	108	48	–	6	M3276-3D-1600A08	31154884

**Ausführung mit scharfer Kante | Auf Anfrage erhältlich**

20,00	20	126	60	–	6	M3276-3D-2000A08	31154886
25,00	25	150	75	–	6	M3276-3D-2500A08	31154887

**Ausführung mit Eckenradius | Lagerhaltige Vorzugsbaureihe**

4,00	6	62	16	0,5	6	M3276-3D-0400A08-R0050	31199168
5,00	6	62	17	0,5	6	M3276-3D-0500A08-R0050	31199169
5,00	6	62	17	1	6	M3276-3D-0500A08-R0100	31199170
6,00	6	62	18	0,5	6	M3276-3D-0600A08-R0050	31199171
6,00	6	62	18	1	6	M3276-3D-0600A08-R0100	31199172
8,00	8	68	24	0,5	6	M3276-3D-0800A08-R0050	31199173
8,00	8	68	24	1	6	M3276-3D-0800A08-R0100	31199174
10,00	10	80	30	0,5	6	M3276-3D-1000A08-R0050	31199175
10,00	10	80	30	1	6	M3276-3D-1000A08-R0100	31199176
12,00	12	93	36	0,5	6	M3276-3D-1200A08-R0050	31199177
12,00	12	93	36	1	6	M3276-3D-1200A08-R0100	31199178
16,00	16	108	48	0,5	6	M3276-3D-1600A08-R0050	31199179
16,00	16	108	48	1	6	M3276-3D-1600A08-R0100	31199180
16,00	16	108	48	2	6	M3276-3D-1600A08-R0200	31199181

**Ausführung mit Eckenradius | Auf Anfrage erhältlich**

20,00	20	126	60	1	6	M3276-3D-2000A08-R0100	31199182
20,00	20	126	60	2	6	M3276-3D-2000A08-R0200	31199183

**Konfigurierbare Merkmale**

**Schaftform:**  
Schaftform: HB

**Spezifikation:**

M3276-3D-1200[**Schaftform**]08-R0050

**Beispiel:**  
M3276-3D-1200**B**08-R0050

Schaftform HB

# OptiMill®-Hardened-Finish

Eckfräser, extra lange Ausführung mit Hals  
M3272

**Ausführung:**  
Fräserdurchmesser: 6,00 - 20,00 mm  
Beschichtung: MFS  
Schneidenzahl: 6  
Spiralwinkel: 55°

**Anwendung:**  
Zum Schlichten von Bauteilen mit einer Härte ab 45 HRC.

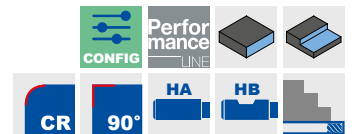
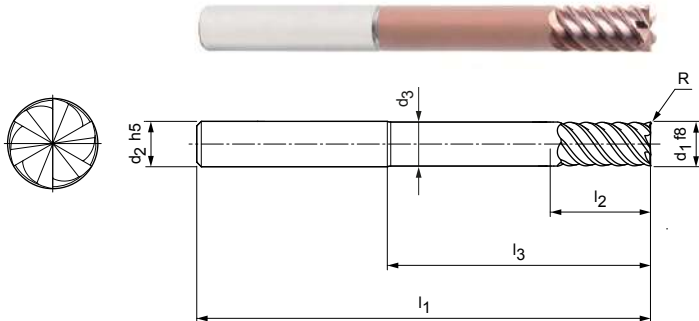

### Ausführung mit scharfer Kante | Lagerhaltige Vorzugsbaureihe

Baumaße							z	Spezifikation	Bestell-Nr.
d1 f8	d2 h5	d3	l1	l2	l3	R			
6,00	6	5,8	80	13	42	–	6	M3272-0600A08	31199086
8,00	8	7,8	100	21	62	–	6	M3272-0800A08	31199087
10,00	10	9,7	100	22	58	–	6	M3272-1000A08	31199088
12,00	12	11,7	120	26	73	–	6	M3272-1200A08	31199089
16,00	16	15,6	150	36	100	–	6	M3272-1600A08	31199150

### Ausführung mit scharfer Kante | Auf Anfrage erhältlich

20,00	20	19,5	150	41	98	–	6	M3272-2000A08	31199151
-------	----	------	-----	----	----	---	---	---------------	----------

### Ausführung mit Eckenradius | Lagerhaltige Vorzugsbaureihe

6,00	6	5,8	80	13	42	0,5	6	M3272-0600A08-R0050	31199184
6,00	6	5,8	80	13	42	1	6	M3272-0600A08-R0100	31199186
8,00	8	7,8	100	21	62	0,5	6	M3272-0800A08-R0050	31199187
8,00	8	7,8	100	21	62	1	6	M3272-0800A08-R0100	31199188
10,00	10	9,7	100	22	58	0,5	6	M3272-1000A08-R0050	31199189
10,00	10	9,7	100	22	58	1	6	M3272-1000A08-R0100	31199190
12,00	12	11,7	120	26	73	0,5	6	M3272-1200A08-R0050	31199191
12,00	12	11,7	120	26	73	1	6	M3272-1200A08-R0100	31199192
16,00	16	15,6	150	36	100	0,5	6	M3272-1600A08-R0050	31199193
16,00	16	15,6	150	36	100	1	6	M3272-1600A08-R0100	31199194
16,00	16	15,6	150	36	100	2	6	M3272-1600A08-R0200	31199195

### Ausführung mit Eckenradius | Auf Anfrage erhältlich

20,00	20	19,5	150	41	98	1	6	M3272-2000A08-R0100	31199196
20,00	20	19,5	150	41	98	2	6	M3272-2000A08-R0200	31199197

### Konfigurierbare Merkmale



**Schaftform:**  
Schaftform: HB



**Spezifikation:**  
M3272-1200[Schaftform]08-R0050

**Beispiel:**  
M3272-1200**B**08-R0050

Schaftform HB

Maßangaben in mm.  
Schnittwertempfehlung siehe Kapitelende.  
Sonderausführungen und andere Beschichtungen auf Anfrage.

# OptiMill®-SPM-Finish

Eckfräser, Ausführung 4xD  
M3434

## Ausführung:

Fräserdurchmesser: 12,00 - 25,00 mm  
Beschichtung: Unbeschichtet  
Schneidenzahl: 4  
Spiralwinkel: 31°

## Anwendung:

Schlichtbearbeitung von Strukturbauteilen aus Aluminium. Bearbeitung von tiefen Taschen und filigranen Bauteilstrukturen auch bei großen Umschlingungen ohne "Pull-Effekt" (beispielsweise an den Taschenecken).

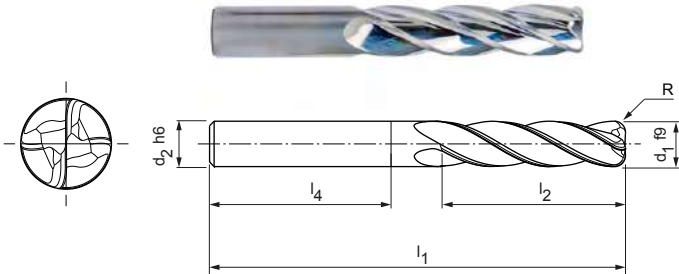

N	1.1	1.2	1.3	1.4	2.1	2.2	2.3	3.1	3.2	4.1	4.2	4.3	C	1.1	1.2	1.3	2.1	3.1	4.1	4.2	5.1	5.2	5.3
---	-----	-----	-----	-----	-----	-----	-----	-----	-----	-----	-----	-----	---	-----	-----	-----	-----	-----	-----	-----	-----	-----	-----



## Metrische Abmessungen | Lagerhaltige Vorzugsbaureihe

Baumaße						z	Spezifikation	Bestell-Nr.
d <sub>1</sub> f9	d <sub>2</sub> h6	l <sub>1</sub>	l <sub>2</sub>	l <sub>4</sub>	R			
12,00	12	100	48	45	2	4	M3434-1200AU-R0200	31111740
12,00	12	100	48	45	3	4	M3434-1200AU-R0300	31082270
16,00	16	123	64	48	3	4	M3434-1600AU-R0300	31082272
16,00	16	123	64	48	4	4	M3434-1600AU-R0400	31082273
20,00	20	140	80	50	3	4	M3434-2000AU-R0300	31082275
20,00	20	140	80	50	4	4	M3434-2000AU-R0400	31082276

## Metrische Abmessungen | Auf Anfrage erhältlich

25,00	25	170	100	56	3	4	M3434-2500AU-R0300	31082277
25,00	25	170	100	56	3	4	M3434-2500BU-R0300	31190643

## Inch-Abmessungen | Auf Anfrage erhältlich

1/2"	1/2"	4"	2"	1,771"	0,12"	4	M3434-1270AU-R0305	31082271
3/4"	3/4"	5 1/2"	3"	1,968"	0,12"	4	M3434-1905AU-R0305	31082274

## Konfigurierbare Merkmale



**Schafform:**  
Schafform: HB



### Spezifikation:

M3434-1200[Schafform]U-R0200

### Beispiel:

M3434-1200BU-R0200

Schafform HB

Maßangaben in mm.

Schnittwertempfehlung siehe Kapitelende.

Sonderausführungen und andere Beschichtungen auf Anfrage.



# Schnittwertempfehlung für Eckfräser

Vorschub und Schnittgeschwindigkeit

## OptiMill-Uni-HPC-Finish | M3096, M3917

MZG*	Werkstoff	Festigkeit/Härte [N/mm <sup>2</sup> ] [HRC]	Kühlung			
			Trocken	Luft/MMS	KSS	
P	P1.1	Bau-, Automaten-, Einsatz- und Vergütungsstähle, unlegiert	< 700	✓	✓	✓
	P1.2	Bau-, Automaten-, Einsatz- und Vergütungsstähle, unlegiert	< 1.200	✓	✓	✓
	P2.1	Nitrier-, Einsatz- und Vergütungsstähle, legiert	< 900	✓	✓	✓
	P2.2	Nitrier-, Einsatz- und Vergütungsstähle, legiert	< 1.400		✓	✓
	P3.1	Werkzeug-, Wälzlager-, Feder- und Schnellarbeitsstähle**	< 800	✓	✓	✓
	P3.2	Werkzeug-, Wälzlager-, Feder- und Schnellarbeitsstähle**	< 1.000		✓	✓
	P3.3	Werkzeug-, Wälzlager-, Feder- und Schnellarbeitsstähle**	< 1.500		✓	✓
	P4.1	Rostfreie Stähle, ferritisch und martensitisch			✓	✓
	P5.1	Stahlguss				✓
	P6.1	Rostfreier Stahlguss, ferritisch und martensitisch				✓
M	M1.1	Rostfreie Stähle, austenitisch	< 700		✓	✓
	M1.2	Rostfreie Stähle, ferritisch/austenitisch (Duplex)	< 1.000			✓
	M2.1	Rostfreier Stahlguss, austenitisch	< 700		✓	✓
	M3.1	Rostfreier Stahlguss, ferritisch/austenitisch (Duplex)	< 1.000			✓
K	K1.1	Gusseisen mit Lamellengraphit (Grauguss), GJL	< 300	✓	✓	✓
	K2.1	Gusseisen mit Kugelgraphit, GJS	< 500	✓	✓	✓
	K2.2	Gusseisen mit Kugelgraphit, GJS	≤ 800	✓	✓	✓
	K2.3	Gusseisen mit Kugelgraphit, GJS	> 800	✓	✓	✓
	K3.1	Gusseisen mit Vermiculargraphit, GJV; Temperguss, GJM	< 500	✓	✓	✓
	K3.2	Gusseisen mit Vermiculargraphit, GJV; Temperguss, GJM	> 500	✓	✓	✓
S	S1.1	Titan, Titanlegierungen	< 400			✓
	S2.1	Titan, Titanlegierungen	< 1.200			✓
	S2.2	Titan, Titanlegierungen	> 1.200			✓

## Korrekturfaktor Werkzeuglänge - $k_{WL}$ 3xD/4xD/5xD \*\*\*

Max. Bearbeitungstiefe $a_p$	$a_e$ max.	Korrekturfaktoren	
		$v_c$	$f_z$
3xD	0,05xD	0,9	0,9
4xD	0,03xD	0,9	0,7
5xD	0,03xD	0,8	0,6

### Hinweis:

Für die Ermittlung der Schnittwerte bitte die Hinweise auf den Seiten 520-523 beachten.

\* MILLER Zerspanungsgruppen

\*\* Wenn die Legierungsbestandteile Cr, Mo, Ni, V, W in Summe > 8 %, dann die nächst höhere MILLER Zerspanungsgruppe wählen.

\*\*\* Für sehr gute Oberflächenergebnisse muss der Vorschub weiter reduziert werden.



Schichten

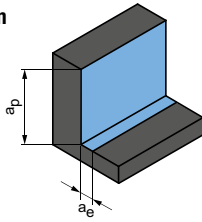

$a_p = 1,5xD$   
 $a_e = 0,1xD$

	$v_c$ [m/min]	$f_z$ [mm]							
		Fräserdurchmesser [mm]							
		4,00	6,00	8,00	10,00	12,00	16,00	20,00	25,00
	<b>385</b>	0,042	0,06	0,077	0,093	0,106	0,13	0,149	0,166
	<b>315</b>	0,039	0,056	0,072	0,086	0,099	0,121	0,139	0,155
	<b>350</b>	0,042	0,06	0,077	0,093	0,106	0,13	0,149	0,166
	<b>245</b>	0,035	0,05	0,064	0,077	0,089	0,108	0,124	0,138
	<b>225</b>	0,041	0,058	0,075	0,089	0,103	0,126	0,144	0,16
	<b>210</b>	0,039	0,055	0,071	0,085	0,097	0,119	0,136	0,152
	<b>190</b>	0,036	0,052	0,067	0,08	0,092	0,113	0,129	0,144
	<b>155</b>	0,028	0,04	0,052	0,062	0,071	0,087	0,099	0,11
	<b>235</b>	0,041	0,058	0,075	0,089	0,103	0,126	0,144	0,16
	<b>155</b>	0,02	0,028	0,036	0,043	0,05	0,061	0,069	0,077
	<b>130</b>	0,025	0,035	0,045	0,054	0,062	0,076	0,087	0,097
	<b>120</b>	0,02	0,029	0,037	0,045	0,051	0,063	0,072	0,08
	<b>145</b>	0,027	0,038	0,049	0,059	0,067	0,082	0,094	0,105
	<b>130</b>	0,021	0,03	0,039	0,046	0,053	0,065	0,074	0,083
	<b>520</b>	0,07	0,101	0,129	0,154	0,177	0,216	0,248	0,276
	<b>475</b>	0,06	0,086	0,109	0,131	0,151	0,184	0,21	0,235
	<b>390</b>	0,049	0,071	0,09	0,108	0,124	0,152	0,173	0,193
	<b>215</b>	0,028	0,04	0,052	0,062	0,071	0,087	0,099	0,11
	<b>345</b>	0,049	0,071	0,09	0,108	0,124	0,152	0,173	0,193
	<b>325</b>	0,042	0,06	0,077	0,093	0,106	0,13	0,149	0,166
	<b>135</b>	0,021	0,030	0,038	0,046	0,052	0,064	0,073	0,082
	<b>120</b>	0,017	0,024	0,031	0,037	0,043	0,052	0,060	0,067
	<b>80</b>	0,015	0,022	0,028	0,033	0,038	0,047	0,053	0,059

Die angegebenen Arbeitswerte sind Richtwerte.  
 Die für den jeweiligen Bearbeitungsfall optimalen Daten sollten im Versuch oder während der Bearbeitung ermittelt werden.

# Schnittwertempfehlung für Eckfräser

Vorschub und Schnittgeschwindigkeit

## OptiMill-Hardened-Finish | M3276

MZG*	Werkstoff	Festigkeit/Härte [N/mm <sup>2</sup> ] [HRC]	Kühlung			
			Trocken	Luft/MMS	KSS	
P	P1.1	Bau-, Automaten-, Einsatz- und Vergütungsstähle, unlegiert	< 700	✓	✓	✓
	P1.2	Bau-, Automaten-, Einsatz- und Vergütungsstähle, unlegiert	< 1.200	✓	✓	✓
	P2.1	Nitrier-, Einsatz- und Vergütungsstähle, legiert	< 900	✓	✓	✓
	P2.2	Nitrier-, Einsatz- und Vergütungsstähle, legiert	< 1.400	✓	✓	✓
	P3.1	Werkzeug-, Wälzlager-, Feder- und Schnellarbeitsstähle**	< 800	✓	✓	✓
	P3.2	Werkzeug-, Wälzlager-, Feder- und Schnellarbeitsstähle**	< 1.000	✓	✓	✓
	P3.3	Werkzeug-, Wälzlager-, Feder- und Schnellarbeitsstähle**	< 1.500	✓	✓	✓
	P4.1	Rostfreie Stähle, ferritisch und martensitisch			✓	✓
	P5.1	Stahlguss			✓	✓
	P6.1	Rostfreier Stahlguss, ferritisch und martensitisch			✓	✓
M	M1.1	Rostfreie Stähle, austenitisch	< 700			✓
	M1.2	Rostfreie Stähle, ferritisch/austenitisch (Duplex)	< 1.000			✓
	M2.1	Rostfreier Stahlguss, austenitisch	< 700			✓
	M3.1	Rostfreier Stahlguss, ferritisch/austenitisch (Duplex)	< 1.000			✓
K	K1.1	Gusseisen mit Lamellengraphit (Grauguss), GJL	< 300	✓	✓	✓
	K2.1	Gusseisen mit Kugelgraphit, GJS	< 500	✓	✓	✓
	K2.2	Gusseisen mit Kugelgraphit, GJS	≤ 800	✓	✓	✓
	K2.3	Gusseisen mit Kugelgraphit, GJS	> 800	✓	✓	✓
	K3.1	Gusseisen mit Vermiculargraphit, GJV; Temperguss, GJM	< 500	✓	✓	✓
	K3.2	Gusseisen mit Vermiculargraphit, GJV; Temperguss, GJM	> 500	✓	✓	✓
H	H1.1	Gehärteter Stahl/Stahlguss	< 44	✓	✓	
	H1.2	Gehärteter Stahl/Stahlguss	< 55	✓	✓	
	H2.1	Gehärteter Stahl/Stahlguss	< 60		✓	
	H2.2	Gehärteter Stahl/Stahlguss	< 65		✓	
	H2.3	Gehärteter Stahl/Stahlguss	< 68		✓	
	H3.1	Verschleißbeständiger Guss/Hartguss, GJN		✓	✓	

## OptiMill-SPM-Finish | M3434

MZG*	Werkstoff	Festigkeit/Härte [N/mm <sup>2</sup> ] [HRC]	Kühlung			
			Trocken	Luft/MMS	KSS	
N	N1.1	Aluminium, unlegiert und legiert <3 % Si		✓	✓	✓
	N1.2	Aluminium, legiert ≤ 7 % Si		✓	✓	✓
	N1.3	Aluminium, legiert > 7-12 % Si		✓	✓	✓
	N1.4	Aluminium, legiert > 12 % Si		✓	✓	✓

\* MILLER Zerspanungsgruppen

\*\* Wenn die Legierungsbestandteile Cr, Mo, Ni, V, W in Summe > 8 %, dann die nächst höhere MILLER Zerspanungsgruppe wählen.

Schichten

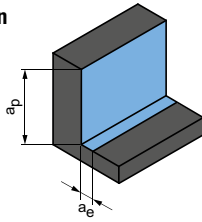

	ap [mm] in % vom D	ae [mm] in % vom D	vc [m/min]	fz [mm]									
				Fräserdurchmesser [mm]									
				4,00	5,00	6,00	8,00	10,00	12,00	14,00	16,00	18,00	20,00
	100	2	200 - 220	0,025	0,030	0,040	0,050	0,065	0,075	0,090	0,105	0,118	0,131
	100	2	180 - 200	0,024	0,029	0,038	0,048	0,062	0,071	0,086	0,100	0,112	0,124
	100	2	180 - 200	0,025	0,030	0,040	0,050	0,065	0,075	0,090	0,105	0,118	0,131
	100	2	160 - 180	0,024	0,029	0,038	0,048	0,062	0,071	0,086	0,100	0,112	0,124
	100	2	180 - 200	0,025	0,030	0,040	0,050	0,065	0,075	0,090	0,105	0,118	0,131
	100	2	160 - 180	0,024	0,029	0,038	0,048	0,062	0,071	0,086	0,100	0,112	0,124
	100	2	140 - 160	0,021	0,026	0,034	0,043	0,055	0,064	0,077	0,089	0,100	0,111
	100	2	140 - 160	0,021	0,026	0,034	0,043	0,055	0,064	0,077	0,089	0,100	0,111
	100	2	140 - 160	0,021	0,026	0,034	0,043	0,055	0,064	0,077	0,089	0,100	0,111
	100	2	150 - 170	0,023	0,027	0,036	0,045	0,059	0,068	0,081	0,095	0,106	0,118
	100	1,8	110 - 130	0,023	0,027	0,036	0,045	0,059	0,068	0,081	0,095	0,106	0,118
	100	1,5	90 - 110	0,021	0,026	0,034	0,043	0,055	0,064	0,077	0,089	0,100	0,111
	100	1,8	110 - 130	0,023	0,027	0,036	0,045	0,059	0,068	0,081	0,095	0,106	0,118
	100	1,5	90 - 130	0,021	0,026	0,034	0,043	0,055	0,064	0,077	0,089	0,100	0,111
	100	2	200 - 220	0,025	0,030	0,040	0,050	0,065	0,075	0,090	0,105	0,118	0,131
	100	2	180 - 200	0,024	0,029	0,038	0,048	0,062	0,071	0,086	0,100	0,112	0,124
	100	2	180 - 200	0,024	0,029	0,038	0,048	0,062	0,071	0,086	0,100	0,112	0,124
	100	2	170 - 190	0,023	0,027	0,036	0,045	0,059	0,068	0,081	0,095	0,106	0,118
	100	2	200 - 220	0,025	0,030	0,040	0,050	0,065	0,075	0,090	0,105	0,118	0,131
	100	2	180 - 200	0,024	0,029	0,038	0,048	0,062	0,071	0,086	0,100	0,112	0,124
	100	1,5	110 - 130	0,021	0,026	0,034	0,043	0,055	0,064	0,077	0,089	0,100	0,111
	100	1,2	90 - 115	0,018	0,021	0,028	0,035	0,046	0,053	0,063	0,074	0,082	0,092
	100	0,8	80 - 100	0,015	0,018	0,024	0,030	0,039	0,045	0,054	0,063	0,071	0,079
	100	0,6	70 - 90	0,013	0,015	0,020	0,025	0,033	0,038	0,045	0,053	0,059	0,066
	100	0,4	60 - 85	0,010	0,012	0,016	0,020	0,026	0,030	0,036	0,042	0,047	0,052
	100	0,8	80 - 100	0,015	0,018	0,024	0,030	0,039	0,045	0,054	0,063	0,071	0,079

Schichten

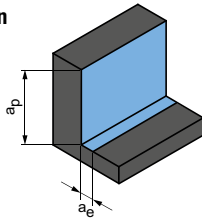

ap = 1xD  
ae = 0,1xD

	vc [m/min]	fz [mm]			
		Fräserdurchmesser [mm]			
		12,00	16,00	20,00	25,00
	985	0,107	0,131	0,150	0,167
	655	0,112	0,137	0,157	0,175
	525	0,118	0,144	0,164	0,184
	380	0,128	0,157	0,179	0,200

Die angegebenen Arbeitswerte sind Richtwerte.  
Die für den jeweiligen Bearbeitungsfall optimalen Daten sollten im Versuch oder während der Bearbeitung ermittelt werden.



# ECKFRÄSER - TROCHOIDES FRÄSEN

## Universeller Einsatz

---

OptiMill-Tro-Uni ..... 422

## Stahl und rostfreier Stahl

---

OptiMill-Tro-PM ..... 425

## Gehärteter Stahl

---

OptiMill-Tro-H ..... 430

## Titan, Inox und Nickelbasislegierungen

---

OptiMill-Tro-Titan ..... 432

OptiMill-Tro-Inox ..... 433

OptiMill-Tro-S ..... 431

## Technischer Anhang

---

Schnittwertempfehlung ..... 438

Anwendungshinweis Trochoides Fräsen ..... 526



# OptiMill®-Tro-Uni

Eckfräser, Ausführung 3xD mit Hals, mit Spanteiler  
M3099-1CD

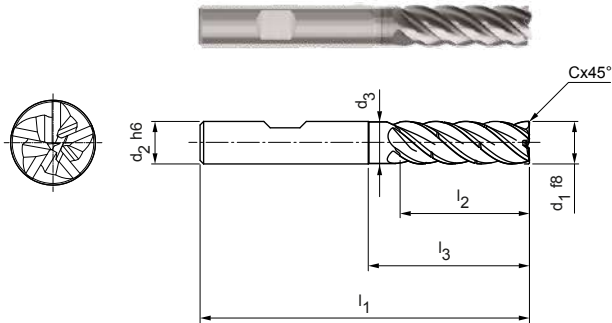

## Ausführung:

Fräserdurchmesser: 4,00 - 20,00 mm  
Beschichtung: MF3  
Schneidenzahl: 5  
Spiralwinkel: ~ 41°  
Wuchtgüte: Schneidenanteil gewuchtet auf G2.5 nach DIN ISO1940-G2.5  
Besonderheiten: Ungleichteilung, Spanteiler

## Anwendung:

Ausführung mit Spanteiler zur optimalen Spankontrolle. Sorgt für verkürzte Späne.

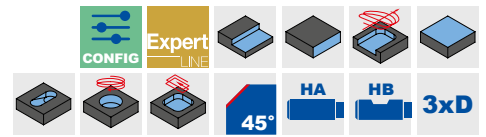

## Lagerhaltige Vorzugsbaureihe

Baumaße							z	Span-teiler	Spezifikation	Bestell-Nr.
d <sub>1</sub> f8	d <sub>2</sub> h6	d <sub>3</sub>	l <sub>1</sub>	l <sub>2</sub>	l <sub>3</sub>	Cx45°				
4,00	6	3,9	62	16	23	0,08	5	1	M3099-0400BY-C0008-1CD	30547814
5,00	6	4,8	62	17	24	0,10	5	1	M3099-0500BY-C0010-1CD	30547815
6,00	6	5,8	62	18	25	0,12	5	1	M3099-0600BY-C0012-1CD	30547816
8,00	8	7,8	68	24	30	0,16	5	1	M3099-0800BY-C0016-1CD	30547818
10,00	10	9,8	80	30	35	0,20	5	1	M3099-1000BY-C0020-1CD	30547819
12,00	12	11,8	93	36	45	0,24	5	2	M3099-1200BY-C0024-2CD	30983095
14,00	14	13,8	99	42	50	0,28	5	2	M3099-1400BY-C0028-2CD	30983096
16,00	16	15,8	108	48	55	0,32	5	2	M3099-1600BY-C0032-2CD	30983097
20,00	20	19,8	126	60	70	0,40	5	2	M3099-2000BY-C0040-2CD	30983098

## Konfigurierbare Merkmale



**Schafform:**  
Schafform: HA



### Spezifikation:

M3099-1200[Schafform]Y-C0024-2CD

### Beispiel:

M3099-1200AY-C0024-2CD

Schafform HA

Maßangaben in mm.

Schnittwertempfehlung siehe Kapitelende.

Sonderausführungen und andere Beschichtungen auf Anfrage.

# OptiMill®-Tro-Uni

Eckfräser, Ausführung 4xD, mit Spanteiler  
M3099-2CD

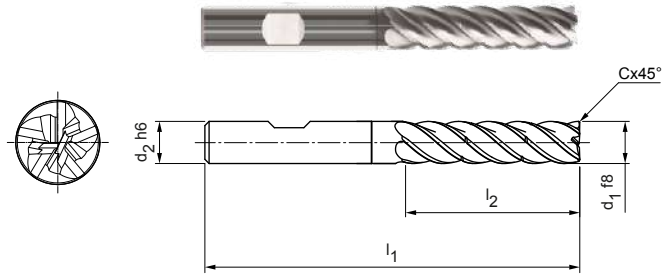

**Ausführung:**  
Fräserdurchmesser: 5,00 - 20,00 mm  
Beschichtung: MF3  
Schneidenzahl: 5  
Spiralwinkel: ~ 41°  
Wuchtgüte: Schneidenanteil gewuchtet auf G2.5 nach DIN ISO1940-G2.5

**Besonderheiten:**  
Ungleichteilung, Spanteiler

**Anwendung:**  
Ausführung mit Spanteiler zur optimalen Spankontrolle. Sorgt für verkürzte Späne.

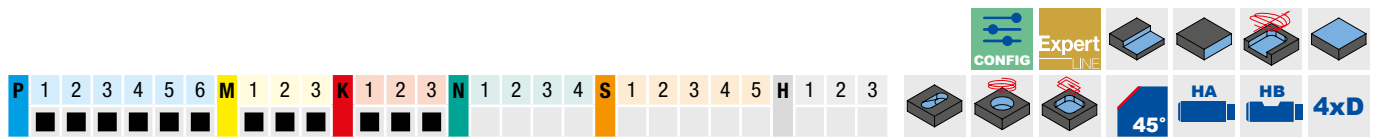

## Lagerhaltige Vorzugsbaureihe

Baumaße					z	Spanteiler	Spezifikation	Bestell-Nr.
d <sub>1</sub> f8	d <sub>2</sub> h6	l <sub>1</sub>	l <sub>2</sub>	Cx45°				
5,00	6	66	20	0,10	5	2	M3099-4D-0500BY-C0010-2CD	30983059
6,00	6	66	24	0,12	5	2	M3099-4D-0600BY-C0012-2CD	30983070
8,00	8	74	32	0,16	5	2	M3099-4D-0800BY-C0016-2CD	30983071
10,00	10	89	40	0,20	5	2	M3099-4D-1000BY-C0020-2CD	30983072
12,00	12	100	48	0,24	5	2	M3099-4D-1200BY-C0024-2CD	30983073
16,00	16	123	64	0,32	5	2	M3099-4D-1600BY-C0032-2CD	30983075
20,00	20	140	80	0,40	5	2	M3099-4D-2000BY-C0040-2CD	30983076

## Auf Anfrage erhältlich

14,00	14	108	56	0,28	5	2	M3099-4D-1400BY-C0028-2CD	30983074
-------	----	-----	----	------	---	---	---------------------------	----------

## Konfigurierbare Merkmale



**Schaftform:**  
Schaftform: HA



**Spezifikation:**  
M3099-4D-1200[**Schaftform**]-C0024-2CD

**Beispiel:**  
M3099-4D-1200**AY**-C0024-2CD

Schaftform HA

Maßangaben in mm.  
Schnittwertempfehlung siehe Kapitelende.  
Sonderausführungen und andere Beschichtungen auf Anfrage.

# OptiMill®-Tro-Uni

Eckfräser, Ausführung 5xD, mit Spanteiler  
M3099-3CD

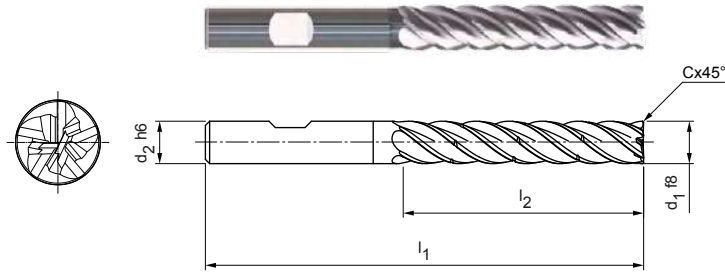

**Ausführung:**

Fräserdurchmesser: 8,00 - 20,00 mm  
 Beschichtung: MF3  
 Schneidenzahl: 5  
 Spiralwinkel: ~ 41°  
 Wuchtgüte: Schneidenanteil gewuchtet auf G2.5 nach DIN ISO1940-G2.5  
 Besonderheiten: Ungleichteilung, Spanteiler

**Anwendung:**

Ausführung mit Spanteiler zur optimalen Spankontrolle. Sorgt für verkürzte Späne.

P
1
2
3
4
5
6
M
1
2
3
K
1
2
3
N
1
2
3
4
S
1
2
3
4
5
H
1
2
3

**Lagerhaltige Vorzugsbaureihe**

Baumaße					z	Spanteiler	Spezifikation	Bestell-Nr.
d1 f8	d2 h6	l1	l2	Cx45°				
8,00	8	81	40	0,16	5	3	M3099-5D-0800BY-C0016-3CD	30983099
10,00	10	96	50	0,20	5	3	M3099-5D-1000BY-C0020-3CD	30983100
12,00	12	112	60	0,24	5	3	M3099-5D-1200BY-C0024-3CD	30983101
16,00	16	136	80	0,32	5	3	M3099-5D-1600BY-C0032-3CD	30983103
20,00	20	160	100	0,40	5	3	M3099-5D-2000BY-C0040-3CD	30983104

**Auf Anfrage erhältlich**

14,00	14	122	70	0,28	5	3	M3099-5D-1400BY-C0028-3CD	30983102
-------	----	-----	----	------	---	---	---------------------------	----------

**Konfigurierbare Merkmale**

**Schaftform:**  
Schaftform: HA

**Spezifikation:**  
M3099-5D-1200[**Schaftform**]-C0024-3CD

**Beispiel:**

M3099-5D-1200**AY**-C0024-3CD

Schaftform HA

Maßangaben in mm.

Schnittwertempfehlung siehe Kapitelende.

Sonderausführungen und andere Beschichtungen auf Anfrage.



# OptiMill®-Tro-PM

Eckfräser, Ausführung 3xD mit Hals, mit Spanteiler  
M3299

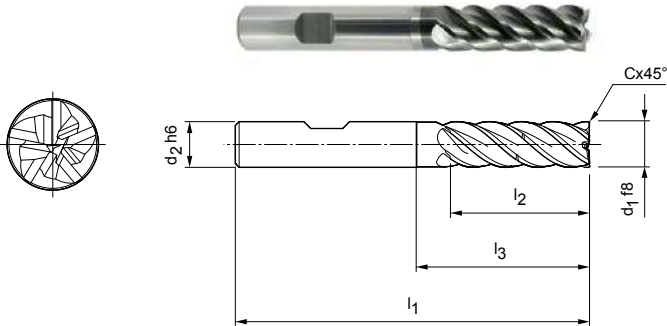

**Ausführung:**  
Fräserdurchmesser: 4,00 - 25,00 mm  
Beschichtung: MF2  
Schneidenzahl: 5  
Spiralwinkel: 41°-42°  
Wuchtgüte: Schneidenanteil gewuchtet auf G2.5 nach DIN ISO1940-G2.5  
  
**Besonderheiten:** Ungleichteilung, Spanteiler

**Anwendung:**  
Ausführung mit Spanteiler zur optimalen Spankontrolle. Sorgt für verkürzte Späne.

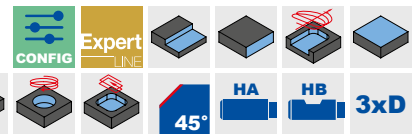

## Lagerhaltige Vorzugsbaureihe

Baumaße						z	Spanteiler	Spezifikation	Bestell-Nr.
d1 f8	d2 h6	l1	l2	l3	Cx45°				
4,00	6	62	16	23	0,08	5	1	M3299-0400BL-C0008	30543767
5,00	6	62	17	24	0,10	5	1	M3299-0500BL-C0010	30543765
6,00	6	62	18	25	0,12	5	1	M3299-0600BL-C0012	30524804
8,00	8	68	24	30	0,16	5	1	M3299-0800BL-C0016	30524805
10,00	10	80	30	35	0,20	5	1	M3299-1000BL-C0020	30524806
12,00	12	93	36	45	0,24	5	1	M3299-1200BL-C0024	30524807
14,00	14	99	42	50	0,28	5	1	M3299-1400BL-C0028	30524808
16,00	16	108	48	55	0,32	5	1	M3299-1600BL-C0032	30524809
18,00	18	117	54	67	0,36	5	1	M3299-1800BL-C0036	30566345
20,00	20	126	60	70	0,40	5	1	M3299-2000BL-C0040	30524810
25,00	25	150	75	92	0,50	5	1	M3299-2500BL-C0050	30566346

## Konfigurierbare Merkmale



**Schaftform:**  
Schaftform: HA



**Spezifikation:**  
M3299-1200[Schaftform]L-C0024

**Beispiel:**  
M3299-1200AL-C0024

Schaftform HA

Maßangaben in mm.  
Schnittwertempfehlung siehe Kapitelende.  
Sonderausführungen und andere Beschichtungen auf Anfrage.

# OptiMill®-Tro-PM

Eckfräser, Ausführung 2xD mit Hals  
M3299-2D

**Ausführung:**  
Fräserdurchmesser: 4,00 - 25,00 mm  
Beschichtung: MF2  
Schneidenzahl: 7  
Spiralwinkel: ~ 40°  
Wuchtgüte: Schneidenanteil gewuchtet auf G2.5 nach DIN ISO1940-G2.5  
  
**Besonderheiten:**  
Ungleichteilung

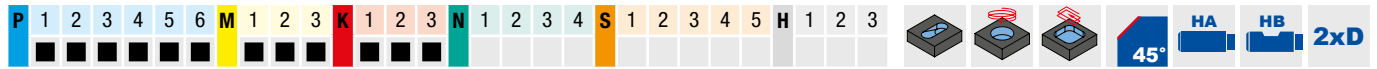
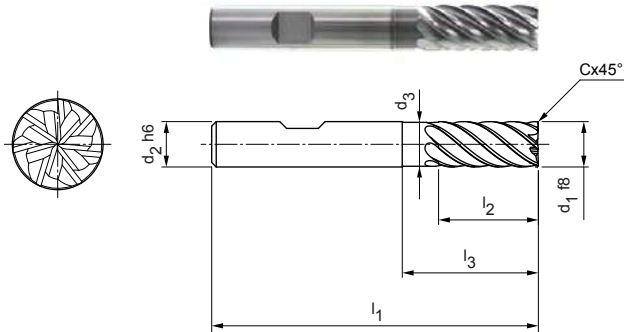

## Lagerhaltige Vorzugsbaureihe

Baumaße							z	Spezifikation	Bestell-Nr.
d1 f8	d2 h6	d3	l1	l2	l3	Cx45°			
4,00	6	-	57	11	-	0,08	7	M3299-2D-0400BL-C0008	30837528
5,00	6	-	57	13	-	0,10	7	M3299-2D-0500BL-C0010	30837529
6,00	6	5,8	57	13	19	0,12	7	M3299-2D-0600BL-C0012	30837530
8,00	8	7,8	63	19	25	0,16	7	M3299-2D-0800BL-C0016	30837531
10,00	10	9,8	72	22	30	0,20	7	M3299-2D-1000BL-C0020	30837532
12,00	12	11,8	83	26	36	0,24	7	M3299-2D-1200BL-C0024	30837533
16,00	16	15,8	92	32	42	0,32	7	M3299-2D-1600BL-C0032	30837536
20,00	20	19,8	104	41	52	0,40	7	M3299-2D-2000BL-C0040	30837538

## Auf Anfrage erhältlich

14,00	14	13,8	83	26	36	0,28	7	M3299-2D-1400BL-C0028	30837534
18,00	18	17,8	92	32	42	0,36	7	M3299-2D-1800BL-C0036	30837537
25,00	25	24,5	125	50	65	0,50	7	M3299-2D-2500BL-C0050	30837539

## Konfigurierbare Merkmale



**Schaftform:**  
Schaftform: HA



**Spezifikation:**  
M3299-2D-1200[**Schaftform**]-C0024

**Beispiel:**  
M3299-2D-1200AL-C0024

Schaftform HA

Maßangaben in mm.  
Schnittwertempfehlung siehe Kapitelende.  
Sonderausführungen und andere Beschichtungen auf Anfrage.

# OptiMill®-Tro-PM

Eckfräser, Ausführung 3xD mit Hals, mit Spanteiler  
M3299-3D

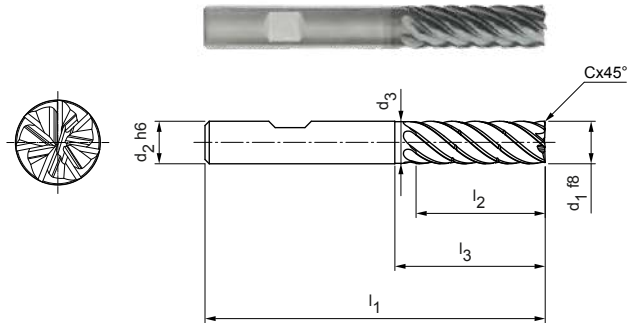

**Ausführung:**  
Fräserdurchmesser: 4,00 - 20,00 mm  
Beschichtung: MF2  
Schneidenzahl: 7  
Spiralwinkel: ~ 40°  
Wuchtgüte: Schneidenanteil gewuchtet auf G2.5 nach DIN ISO1940-G2.5  
Besonderheiten: Ungleichteilung, Spanteiler

**Anwendung:**  
Ausführung mit Spanteiler zur optimalen Spankontrolle. Sorgt für verkürzte Späne.

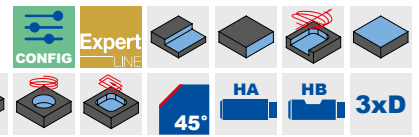

### Lagerhaltige Vorzugsbaureihe

Baumaße							z	Spanteiler	Spezifikation	Bestell-Nr.
d1 f8	d2 h6	d3	l1	l2	l3	Cx45°				
4,00	6	3,9	62	16	23	0,08	7	1	M3299-3D-0400BL-C0008-1CD z=7	30838298
5,00	6	4,8	62	17	24	0,10	7	1	M3299-3D-0500BL-C0010-1CD z=7	30838299
6,00	6	5,8	62	18	25	0,12	7	1	M3299-3D-0600BL-C0012-1CD z=7	30838301
8,00	8	7,8	68	24	30	0,16	7	1	M3299-3D-0800BL-C0016-1CD z=7	30838302
10,00	10	9,8	80	30	35	0,20	7	1	M3299-3D-1000BL-C0020-1CD z=7	30838304
12,00	12	11,8	93	36	45	0,24	7	2	M3299-3D-1200BL-C0024-2CD z=7	30983077
16,00	16	15,8	108	48	55	0,32	7	2	M3299-3D-1600BL-C0032-2CD z=7	30983079
20,00	20	19,8	126	60	70	0,40	7	2	M3299-3D-2000BL-C0040-2CD z=7	30983080

### Auf Anfrage erhältlich

14,00	14	13,8	99	42	50	0,28	7	2	M3299-3D-1400BL-C0028-2CD z=7	30983078
-------	----	------	----	----	----	------	---	---	-------------------------------	----------

### Konfigurierbare Merkmale



**Schaftform:**  
Schaftform: HA



**Spezifikation:**  
M3299-3D-12000[**Schaftform**]L-C0024-2CD z=7

**Beispiel:**  
M3299-3D-1200AL-C0024-2CD z=7

Schaftform HA

Maßangaben in mm.  
Schnittwertempfehlung siehe Kapitelende.  
Sonderausführungen und andere Beschichtungen auf Anfrage.

# OptiMill®-Tro-PM

Eckfräser, Ausführung 4xD, mit Spanteiler  
M3299-4D

**Ausführung:**

Fräserdurchmesser: 6,00 - 20,00 mm  
 Beschichtung: MF2  
 Schneidzahl: 7  
 Spiralwinkel: ~ 38°  
 Besonderheiten: Ungleichteilung, Spanteiler

**Anwendung:**

Ausführung mit Spanteiler zur optimalen Spankontrolle. Sorgt für verkürzte Späne.

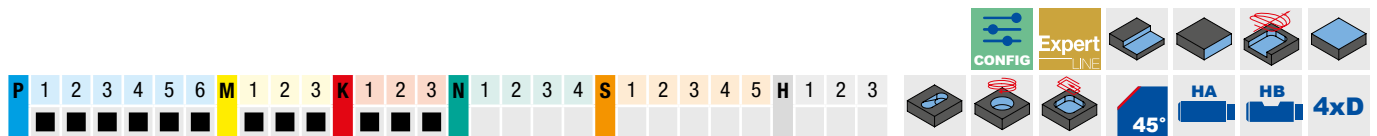
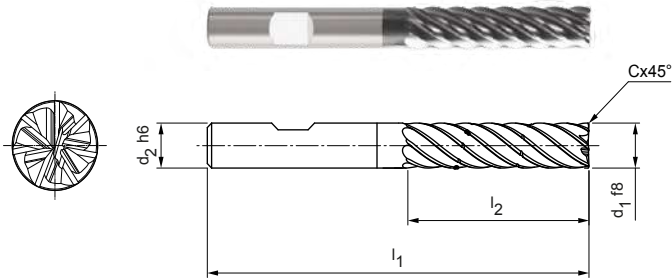

**Lagerhaltige Vorzugsbaureihe**

Baumaße					z	Spanteiler	Spezifikation	Bestell-Nr.
d1 f8	d2 h6	l1	l2	Cx45°				
6,00	6	66	24	0,12	7	2	M3299-4D-0600BL-C0012-2CD	30983082
8,00	8	74	32	0,16	7	2	M3299-4D-0800BL-C0016-2CD	30983083
10,00	10	89	40	0,20	7	2	M3299-4D-1000BL-C0020-2CD	30983084
12,00	12	100	48	0,24	7	2	M3299-4D-1200BL-C0024-2CD	30983085
16,00	16	123	64	0,32	7	2	M3299-4D-1600BL-C0032-2CD	30983087
20,00	20	140	80	0,40	7	2	M3299-4D-2000BL-C0040-2CD	30983088

**Auf Anfrage erhältlich**

14,00	14	108	56	0,28	7	2	M3299-4D-1400BL-C0028-2CD	30983086
-------	----	-----	----	------	---	---	---------------------------	----------

**Konfigurierbare Merkmale**



**Schaftform:**  
Schaftform: HA



**Spezifikation:**  
M3299-4D-1200[**Schaftform**]-C0024-2CD

**Beispiel:**

M3299-4D-1200AL-C0024-2CD

Schaftform HA

Maßangaben in mm.

Schnittwertempfehlung siehe Kapitelende.

Sonderausführungen und andere Beschichtungen auf Anfrage.

# OptiMill®-Tro-PM

Eckfräser, Ausführung 5xD, mit Spanteiler  
M3299-5D

**Ausführung:**

Fräserdurchmesser: 8,00 - 20,00 mm  
 Beschichtung: MF2  
 Schneidenzahl: 7  
 Spiralwinkel: ~ 36°  
 Besonderheiten: Ungleichteilung, Spanteiler

**Anwendung:**

Ausführung mit Spanteiler zur optimalen Spankontrolle. Sorgt für verkürzte Späne.

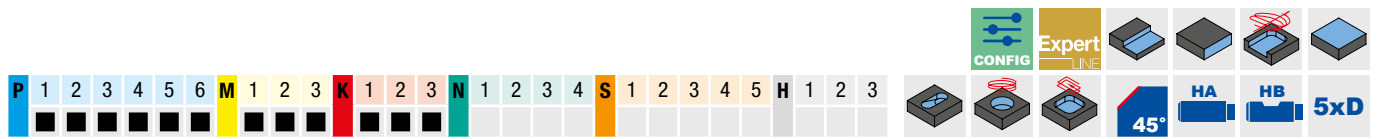
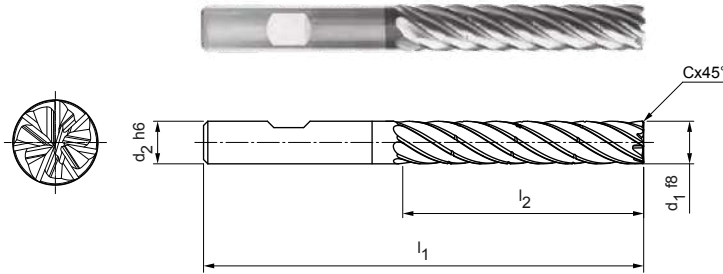

**Lagerhaltige Vorzugsbaureihe**

Baumaße					z	Spanteiler	Spezifikation	Bestell-Nr.
d1 f8	d2 h6	l1	l2	Cx45°				
8,00	8	81	40	0,16	7	3	M3299-5D-0800BL-C0016-3CD	30983089
10,00	10	96	50	0,20	7	3	M3299-5D-1000BL-C0020-3CD	30983090
12,00	12	112	60	0,24	7	3	M3299-5D-1200BL-C0024-3CD	30983091
16,00	16	136	80	0,32	7	3	M3299-5D-1600BL-C0032-3CD	30983093
20,00	20	160	100	0,40	7	3	M3299-5D-2000BL-C0040-3CD	30983094

**Auf Anfrage erhältlich**

14,00	14	122	70	0,28	7	3	M3299-5D-1400BL-C0028-3CD	30983092
-------	----	-----	----	------	---	---	---------------------------	----------

**Konfigurierbare Merkmale**



**Schaftform:**  
Schaftform: HA



**Spezifikation:**  
M3299-5D-1200[**Schaftform**]-C0024-3CD

**Beispiel:**

M3299-5D-1200**AL**-C0024-3CD

Schaftform HA

Maßangaben in mm.

Schnittwertempfehlung siehe Kapitelende.

Sonderausführungen und andere Beschichtungen auf Anfrage.

# OptiMill®-Tro-H

Eckfräser, Ausführung 3xD mit Hals, mit Spanteiler  
M3079

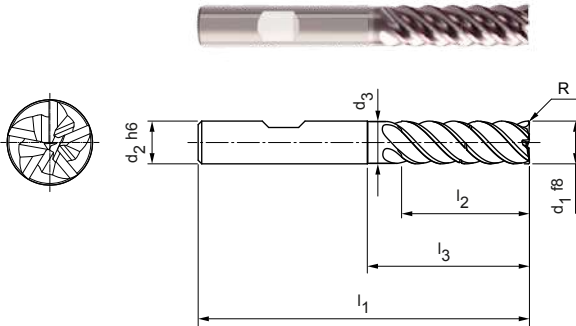

**Ausführung:**  
Fräserdurchmesser: 6,00 - 25,00 mm  
Beschichtung: MxS  
Schneidenzahl: 5  
Spiralwinkel: 41°-42°  
Wuchtgüte: Schneidenanteil gewuchtet auf G2.5 nach DIN ISO1940-G2.5

**Besonderheiten:**  
Ungleichteilung, Spanteiler

**Anwendung:**  
Ausführung mit Spanteiler zur optimalen Spankontrolle. Sorgt für verkürzte Späne.



## Lagerhaltige Vorzugsbaureihe

Baumaße							z	Spanteiler	Spezifikation	Bestell-Nr.
d <sub>1</sub> f8	d <sub>2</sub> h6	d <sub>3</sub>	l <sub>1</sub>	l <sub>2</sub>	l <sub>3</sub>	R				
6,00	6	5,8	62	18	25	0,1	5	1	M3079-0600BS-R0010-1CD	30983050
8,00	8	7,8	68	24	30	0,2	5	1	M3079-0800BS-R0020-1CD	30983051
10,00	10	9,8	80	30	35	0,2	5	1	M3079-1000BS-R0020-1CD	30983052
12,00	12	11,8	93	36	45	0,3	5	1	M3079-1200BS-R0030-1CD	30983053
14,00	14	13,8	99	42	50	0,3	5	1	M3079-1400BS-R0030-1CD	30983054
16,00	16	15,8	108	48	55	0,3	5	1	M3079-1600BS-R0030-1CD	30983055
20,00	20	19,8	126	60	70	0,3	5	1	M3079-2000BS-R0030-1CD	30983057

## Auf Anfrage erhältlich

18,00	18	17,8	117	54	67	0,3	5	1	M3079-1800BS-R0030-1CD	30983056
25,00	25	24,5	150	75	92	0,4	5	1	M3079-2500BS-R0040-1CD	30983058

## Konfigurierbare Merkmale



**Schaftform:**  
Schaftform: HA



**Spezifikation:**  
M3079-1200[**Schaftform**]S-R0030-1CD

**Beispiel:**  
M3079-1200AS-R0030-1CD

Schaftform HA

Maßangaben in mm.  
Schnittwertempfehlung siehe Kapitelende.  
Sonderausführungen und andere Beschichtungen auf Anfrage.

# OptiMill®-Tro-S

Eckfräser, Ausführung 3xD mit Hals  
M3699

**Ausführung:**  
Fräserdurchmesser: 6,00 - 25,00 mm  
Beschichtung: MF18  
Schneidenzahl: 5  
Spiralwinkel: 41°-42°  
Wuchtgüte: Schneidenanteil gewuchtet auf G2.5 nach DIN ISO1940-G2.5  
  
**Besonderheiten:**  
Ungleichteilung

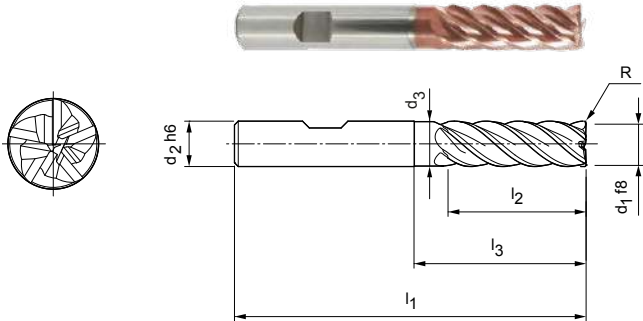

Product configuration bar with icons for various features:

- CONFIG (blue)
- Expert (yellow)
- CR (blue)
- HA (blue)
- HB (blue)
- 3xD (blue)

## Lagerhaltige Vorzugsbaureihe

Baumaße							z	Spezifikation	Bestell-Nr.
d1 f8	d2 h6	d3	l1	l2	l3	R			
6,00	6	5,8	62	18	25	0,1	5	M3699-0600B13-R0010	31335625
8,00	8	7,8	68	24	30	0,2	5	M3699-0800B13-R0020	31335626
10,00	10	9,8	80	30	35	0,2	5	M3699-1000B13-R0020	31335627
12,00	12	11,8	93	36	45	0,3	5	M3699-1200B13-R0030	31335628
16,00	16	15,8	108	48	55	0,3	5	M3699-1600B13-R0030	31335640
20,00	20	19,8	126	60	70	0,3	5	M3699-2000B13-R0030	31335643

## Auf Anfrage erhältlich

14,00	14	13,8	99	42	50	0,3	5	M3699-1400B13-R0030	31335629
18,00	18	17,8	117	54	67	0,3	5	M3699-1800B13-R0030	31335641
25,00	25	24,5	150	75	92	0,4	5	M3699-2500B13-R0040	31335644

## Konfigurierbare Merkmale

**Schaftform:**  
Schaftform: HA

**Spezifikation:**  
M3699-1200[Schaftform]13-R0030

**Beispiel:**  
M3699-1200A13-R0030

Schaftform HA

Maßangaben in mm.  
Schnittwertempfehlung siehe Kapitelende.  
Sonderausführungen und andere Beschichtungen auf Anfrage.

# OptiMill®-Tro-Titan

Eckfräser, Ausführung 3xD mit Hals  
M3799

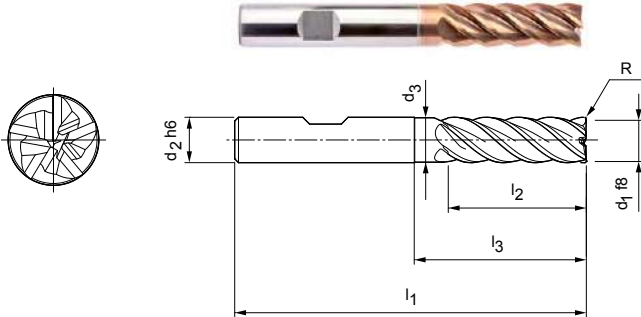

## Ausführung:

Fräserdurchmesser: 6,00 - 25,00 mm  
 Beschichtung: MF18  
 Schneidenzahl: 5  
 Spiralwinkel: 41°-42°  
 Wuchtgüte: Schneidenanteil gewuchtet auf G2.5 nach DIN ISO1940-G2.5  
 Besonderheiten: Ungleichteilung

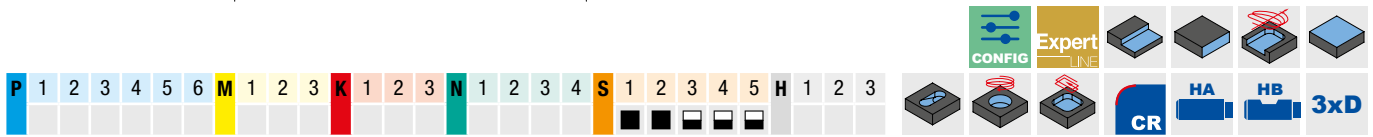

## Lagerhaltige Vorzugsbaureihe

Baumaße							z	Spezifikation	Bestell-Nr.
d1 f8	d2 h6	d3	l1	l2	l3	R			
6,00	6	5,8	62	18	25	0,1	5	M3799-0600B13-R0010	30651019
8,00	8	7,8	68	24	30	0,2	5	M3799-0800B13-R0020	30651020
10,00	10	9,8	80	30	35	0,2	5	M3799-1000B13-R0020	30651021
12,00	12	11,8	93	36	45	0,3	5	M3799-1200B13-R0030	30651022
16,00	16	15,8	108	48	55	0,3	5	M3799-1600B13-R0030	30651024
20,00	20	19,8	126	60	70	0,3	5	M3799-2000B13-R0030	30651026

## Auf Anfrage erhältlich

14,00	14	–	99	42	50	0,3	5	M3799-1400B13-R0030	30651023
18,00	18	–	117	54	67	0,3	5	M3799-1800B13-R0030	30651025
25,00	25	–	150	75	92	0,4	5	M3799-2500B13-R0040	30651027

## Konfigurierbare Merkmale



**Schaftform:**  
Schaftform: HA



**Spezifikation:**  
M3799-1200[Schaftform]13-R0030

Beispiel:  
M3799-1200A13-R0030

Schaftform HA

Maßangaben in mm.

Schnittwertempfehlung siehe Kapitelende.

Sonderausführungen und andere Beschichtungen auf Anfrage.



# OptiMill®-Tro-Inox

Eckfräser, Ausführung 2xD mit Hals, mit Spanteiler  
M3399-2D

**Ausführung:**

Fräserdurchmesser: 4,00 - 25,00 mm  
 Beschichtung: MF18  
 Schneidanzahl: 6  
 Spiralwinkel: 36°  
 Besonderheit: Schneidenteil gewuchtet auf G2.5 nach DIN ISO1940-G2.5

**Anwendung:**

Ausführung mit Spanteiler zur optimalen Spankontrolle. Sorgt für verkürzte Späne.

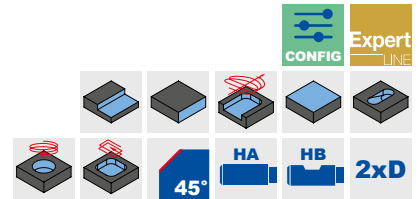
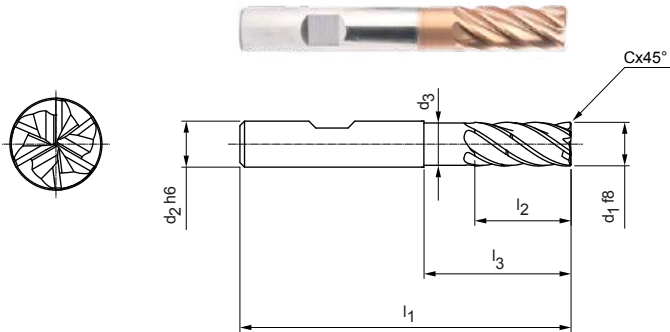

**Lagerhaltige Vorzugsbaureihe**

Baumaße							z	Span-teiler	Schaffform HB	
d1 f8	d2 h6	d3	l1	l2	l3	C x 45°			Spezifikation	Bestell-Nr.
4,00	6	3,9	57	11	13	0,08	6	-	M3399-2D-0400B13-C0008	31348703
5,00	6	4,8	57	13	15,5	0,1	6	-	M3399-2D-0500B13-C0010	31348704
6,00	6	5,8	57	13	19	0,12	6	-	M3399-2D-0600B13-C0012	31348705
8,00	8	7,8	63	19	25	0,16	6	-	M3399-2D-0800B13-C0016	31348706
10,00	10	9,8	72	22	30	0,2	6	-	M3399-2D-1000B13-C0020	31348707
12,00	12	11,8	83	26	36	0,24	6	1	M3399-2D-1200B13-C0024-1CD	31348708
16,00	16	15,8	92	32	42	0,32	6	1	M3399-2D-1600B13-C0032-1CD	31348740
20,00	20	19,8	104	41	52	0,4	6	1	M3399-2D-2000B13-C0040-1CD	31348742

**Auf Anfrage erhältlich**

14,00	14	13,8	83	26	36	0,28	6	1	M3399-2D-1400B13-C0028-1CD	31348709
18,00	18	17,8	92	32	42	0,36	6	1	M3399-2D-1800B13-C0036-1CD	31348741
25,00	25	24,5	125	50	65	0,5	6	1	M3399-2D-2500B13-C0050-1CD	31348743

**Konfigurierbare Merkmale**



**Schaffform:**  
Schaffform: HA



**Spezifikation:**  
M3399-2D-1200[Schaffform]13-C0024-1CD

**Beispiel:**

M3399-2D-1200A13-C0024-1CD

Schaffform HA

Maßangaben in mm.

Schnittwertempfehlung am Ende des Dokuments.

Sonderausführungen und andere Beschichtungen auf Anfrage.

# OptiMill®-Tro-Inox

Eckfräser, Ausführung 3xD mit Hals, mit Spanteiler  
M3399-3D

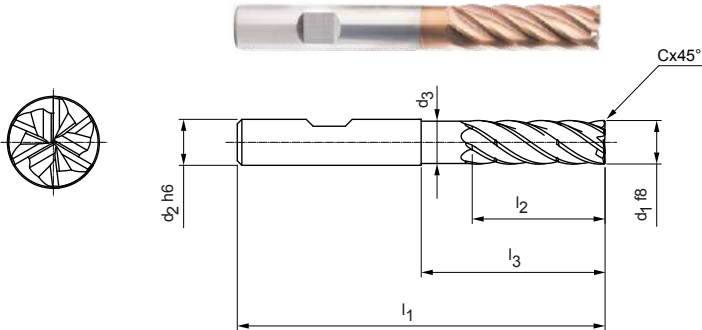

**Ausführung:**

Fräserdurchmesser: 4,00 - 25,00 mm  
 Beschichtung: MF18  
 Schneidanzahl: 6  
 Spiralwinkel: 36°  
 Besonderheit: Schneidenteil gewuchtet auf G2.5 nach DIN ISO1940-G2.5

**Anwendung:**

Ausführung mit Spanteiler zur optimalen Spankontrolle. Sorgt für verkürzte Späne.

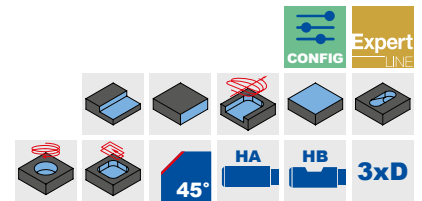

**Lagerhaltige Vorzugsbaureihe**

Baumaße							z	Span-teiler	Schaffform HB	
d <sub>1</sub> f8	d <sub>2</sub> h6	d <sub>3</sub>	l <sub>1</sub>	l <sub>2</sub>	l <sub>3</sub>	C x 45°			Spezifikation	Bestell-Nr.
4,00	6	3,9	62	16	23	0,08	6	1	M3399-3D-0400B13-C0008-1CD	31348744
5,00	6	4,8	62	17	24	0,1	6	1	M3399-3D-0500B13-C0010-1CD	31348745
6,00	6	5,8	62	18	25	0,12	6	1	M3399-3D-0600B13-C0012-1CD	31348746
8,00	8	7,8	68	24	30	0,16	6	1	M3399-3D-0800B13-C0016-1CD	31348747
10,00	10	9,8	80	30	35	0,2	6	1	M3399-3D-1000B13-C0020-1CD	31348748
12,00	12	11,8	93	36	45	0,24	6	2	M3399-3D-1200B13-C0024-2CD	31348749
14,00	14	13,8	99	42	50	0,28	6	2	M3399-3D-1400B13-C0028-2CD	31348750
16,00	16	15,8	108	48	55	0,32	6	2	M3399-3D-1600B13-C0032-2CD	31348751
20,00	20	19,8	126	60	70	0,4	6	2	M3399-3D-2000B13-C0040-2CD	31348753

**Auf Anfrage erhältlich**

18,00	18	17,8	117	54	67	0,36	6	2	M3399-3D-1800B13-C0036-2CD	31348752
25,00	25	24,5	150	75	92	0,5	6	2	M3399-3D-2500B13-C0050-2CD	31348754

**Konfigurierbare Merkmale**

**Schaffform:**  
Schaffform: HA

**Spezifikation:**  
M3399-3D-1200[Schaffform]13-C0024-2CD

**Beispiel:**

M3399-3D-1200A13-C0024-2CD

Schaffform HA

Maßangaben in mm.

Schnittwertempfehlung am Ende des Dokuments.

Sonderausführungen und andere Beschichtungen auf Anfrage.

# OptiMill®-Tro-Inox

Eckfräser, Ausführung 4xD, mit Spanteiler  
M3399-4D

**Ausführung:**

Fräserdurchmesser: 5,00 - 25,00 mm  
 Beschichtung: MF18  
 Schneidanzahl: 6  
 Spiralwinkel: 36°  
 Besonderheit: Schneidenteil gewuchtet auf G2.5 nach DIN ISO1940-G2.5

**Anwendung:**

Ausführung mit Spanteiler zur optimalen Spankontrolle. Sorgt für verkürzte Späne.

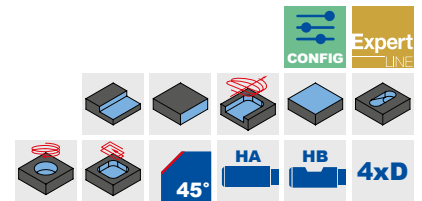
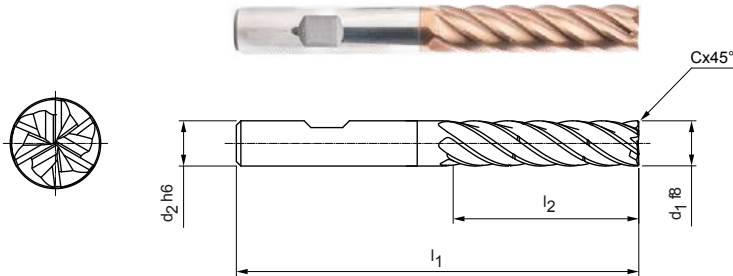

**Lagerhaltige Vorzugsbaureihe**

Baumaße					z	Span-teiler	Schaffform HB	
d <sub>1</sub> f8	d <sub>2</sub> h6	l <sub>1</sub>	l <sub>2</sub>	C x 45°			Spezifikation	Bestell-Nr.
5,00	6	66	20	0,10	6	2	M3399-4D-0500B13-C0010-2CD	31348755
6,00	6	66	24	0,12	6	2	M3399-4D-0600B13-C0012-2CD	31348756
8,00	8	74	32	0,16	6	2	M3399-4D-0800B13-C0016-2CD	31348757
10,00	10	89	40	0,20	6	2	M3399-4D-1000B13-C0020-2CD	31348758
12,00	12	100	48	0,24	6	2	M3399-4D-1200B13-C0024-2CD	31348759
16,00	16	123	64	0,32	6	2	M3399-4D-1600B13-C0032-2CD	31348761
20,00	20	140	80	0,40	6	2	M3399-4D-2000B13-C0040-2CD	31348763

**Auf Anfrage erhältlich**

14,00	14	108	56	0,28	6	2	M3399-4D-1400B13-C0028-2CD	31348760
18,00	18	130	72	0,36	6	2	M3399-4D-1800B13-C0036-2CD	31348762
25,00	25	170	100	0,5	6	2	M3399-4D-2500B13-C0050-2CD	31348764

**Konfigurierbare Merkmale**



**Schaffform:**  
Schaffform: HA



**Spezifikation:**  
M3399-4D-1200[Schaffform]13-C0024-2CD

**Beispiel:**

M3399-4D-1200A13-C0024-2CD

Schaffform HA

Maßangaben in mm.

Schnittwertempfehlung am Ende des Dokuments.

Sonderausführungen und andere Beschichtungen auf Anfrage.

# OptiMill®-Tro-Inox

Eckfräser, Ausführung 5xD, mit Spanteiler  
M3399-5D

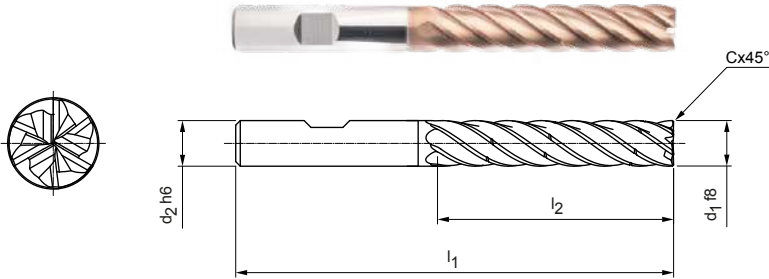

**Ausführung:**

Fräserdurchmesser: 8,00 - 25,00 mm  
 Beschichtung: MF18  
 Schneidanzahl: 6  
 Spiralwinkel: 36°  
 Besonderheit: Schneidenteil gewuchtet auf G2.5 nach DIN ISO1940-G2.5

**Anwendung:**

Ausführung mit Spanteiler zur optimalen Spankontrolle. Sorgt für verkürzte Späne.

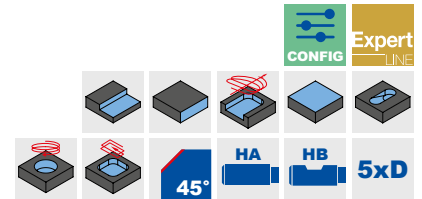

**Lagerhaltige Vorzugsbaureihe**

Baumaße					z	Span-teiler	Schaffform HB	
d <sub>1</sub> f8	d <sub>2</sub> h6	l <sub>1</sub>	l <sub>2</sub>	C x 45°			Spezifikation	Bestell-Nr.
8,00	8	81	40	0,16	6	3	M3399-5D-0800B13-C0016-3CD	31348765
10,00	10	96	50	0,20	6	3	M3399-5D-1000B13-C0020-3CD	31348766
12,00	12	112	60	0,24	6	3	M3399-5D-1200B13-C0024-3CD	31348767
16,00	16	136	80	0,32	6	3	M3399-5D-1600B13-C0032-3CD	31348769
20,00	20	160	100	0,40	6	3	M3399-5D-2000B13-C0040-3CD	31348771

**Auf Anfrage erhältlich**

14	14	122	70	0,28	6	3	M3399-5D-1400B13-C0028-3CD	31348768
18	18	147	90	0,36	6	3	M3399-5D-1800B13-C0036-3CD	31348770
25	25	195	125	0,5	6	3	M3399-5D-2500B13-C0050-3CD	31348772

**Konfigurierbare Merkmale**



**Schaffform:**  
Schaffform: HA



**Spezifikation:**  
M3399-5D-1200[Schaffform]13-C0024-3CD

**Beispiel:**

M3399-5D-1200A13-C0024-3CD

Schaffform HA

Maßangaben in mm.

Schnittwertempfehlung am Ende des Dokuments.

Sonderausführungen und andere Beschichtungen auf Anfrage.

**Kombination Hydrodehn-Spanntechnik**

Neu entwickelte Hydrodehn-Spannsysteme ermöglichen hohe Bearbeitungsparameter durch hervorragende Stabilität und Genauigkeit. Die Systeme minimieren selbsterregte Schwingungen wodurch eingespannte Werkzeuge keinen Mikroschwingungen ausgesetzt werden.

# Schnittwertempfehlung für Trochoidfräser

Vorschub und Schnittgeschwindigkeit

### Korrekturfaktoren

Faktor	v <sub>c</sub>			a <sub>e</sub>	h <sub>m</sub> max.
	P	K	M		
2xD	1,10		1,05	1,05	1,05
3xD	1,00		1,00	1,00	1,00
4xD	0,85		0,92	0,90	0,94
5xD	0,60		0,80	0,80	0,87

OptiMill-Tro-Uni | M3099

OptiMill-Tro-PM | M3299

MZG*	Werkstoff	Festigkeit/Härte [N/mm <sup>2</sup> ] [HRC]	Kühlung				
			MMS/Luft	Trocken	KSS		
P	P1.1	Bau-, Automaten-, Einsatz- und Vergütungsstähle, unlegiert	< 700	✓	✓	✓	
	P1.2	Bau-, Automaten-, Einsatz- und Vergütungsstähle, unlegiert	< 1.200	✓	✓	✓	
	P2.1	Nitrier-, Einsatz- und Vergütungsstähle, legiert	< 900	✓	✓	✓	
	P2.2	Nitrier-, Einsatz- und Vergütungsstähle, legiert	< 1.400	✓		✓	
	P3.1	Werkzeug-, Wälzlager-, Feder- und Schnellarbeitsstähle**	< 800	✓	✓	✓	
	P3.2	Werkzeug-, Wälzlager-, Feder- und Schnellarbeitsstähle**	< 1.000	✓		✓	
	P3.3	Werkzeug-, Wälzlager-, Feder- und Schnellarbeitsstähle**	< 1.500	✓		✓	
	P4	P4.1	Rostfreie Stähle, ferritisch und martensitisch		✓		✓
	P5	P5.1	Stahlguss				
	P6	P6.1	Rostfreier Stahlguss, ferritisch und martensitisch				✓
M	M1.1	Rostfreie Stähle, austenitisch	< 700	✓		✓	
	M1.2	Rostfreie Stähle, ferritisch/austenitisch (Duplex)	< 1.000			✓	
	M2	M2.1	Rostfreier Stahlguss, austenitisch	< 700	✓		✓
	M3	M3.1	Rostfreier Stahlguss, ferritisch/austenitisch (Duplex)	< 1.000			✓
K	K1.1	Gusseisen mit Lamellengraphit (Grauguss), GJL	< 300	✓	✓	✓	
	K2.1	Gusseisen mit Kugelgraphit, GJS	< 500	✓	✓	✓	
	K2	K2.2	Gusseisen mit Kugelgraphit, GJS	≤ 800	✓	✓	✓
		K2.3	Gusseisen mit Kugelgraphit, GJS	> 800	✓	✓	✓
	K3	K3.1	Gusseisen mit Vermiculargraphit, GJV; Temperguss, GJM	< 500	✓	✓	✓
		K3.2	Gusseisen mit Vermiculargraphit, GJV; Temperguss, GJM	> 500	✓	✓	✓

### Berechnungsbeispiel für 42CrMo4 ø 12 mm:

$$f_z \mid a_e \mid h_m \text{ max.} = \frac{D}{100} \cdot \text{Wert siehe Tabelle}$$

P2.2	Nitrier-, Einsatz- und Vergütungsstähle, legiert	< 1400	✓	✓	<b>280 - 380</b>	1,0 - 1,6	8 - 12	0,56 - 0,68
------	--	--------	---	---	------------------	-----------	--------	-------------

$$1 \quad f_z = \frac{12 \text{ mm}}{100} \cdot 1,2 = 0,144 \text{ mm}$$

$$2 \quad a_e = \frac{12 \text{ mm}}{100} \cdot 10 = 1,2 \text{ mm}$$

$$3 \quad h_m \text{ max.} = \frac{12 \text{ mm}}{100} \cdot 0,6 = 0,072 \text{ mm}$$

#### Hinweis:

Beim Trochoidfräsen verändern sich die angegebenen Schnittbedingungen während des Bearbeitungsprozesses. Dies ist auch abhängig von der verwendeten CAM-Software sowie der Bearbeitungsstellung des Werkzeugs im Werkstück. Vorschub und Eingriffsbreite bzw. Eingriffswinkel ändern sich während der Bearbeitung ständig, um je nach Kontur eine möglichst konstante Spanmittendicke zu erzielen.

\* MILLER Zerspanungsgruppen

\*\* Wenn die Legierungsbestandteile Cr, Mo, Ni, V, W in Summe > 8 %, dann die nächst höhere MILLER Zerspanungsgruppe wählen.

**Trochoides Fräsen**

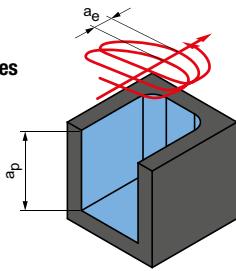

$a_p$  = abhängig von max. Bearbeitungstiefe des Werkzeugs  
 $a_e$  = abhängig vom Werkstoff

$v_c$ [m/min]	$f_z$ [mm] in % vom D	$a_e$ [mm] in % vom D	$h_m$ max. [mm] in % vom D	Bearbeitungsbeispiel	
380 - 520	1,4 - 2,0	14 - 18	0,66 - 0,80	<b>16MnCr5</b> $\varnothing = 12$ mm $v_c = 500$ m/min $f_z = 0,28$ mm $a_e = 1,8$ mm $a_p = 32$ mm	<b>42CrMo4</b> $\varnothing = 12$ mm $v_c = 375$ m/min $f_z = 0,17$ mm $a_e = 1,2$ mm $a_p = 32$ mm
320 - 460	1,2 - 1,8	12 - 16	0,62 - 0,76		
340 - 480	1,2 - 1,8	10 - 14	0,58 - 0,71		
280 - 380	1,0 - 1,6	8 - 12	0,56 - 0,68		
250 - 360	1,1 - 1,7	9 - 15	0,56 - 0,67		
230 - 340	0,9 - 1,5	8 - 13	0,54 - 0,64		
210 - 320	0,8 - 1,4	6 - 12	0,52 - 0,62		
180 - 260	0,8 - 1,2	6 - 12	0,50 - 0,60		
220 - 300	1,2 - 1,8	8 - 12	0,54 - 0,62		
160 - 240	0,8 - 1,4	6 - 12	0,50 - 0,60	<b>X5CrNi18-8</b> $\varnothing = 12$ mm $v_c = 180$ m/min $f_z = 0,09$ mm	$a_e = 1,2$ mm $a_p = 32$ mm
140 - 220	0,6 - 1,0	5 - 10	0,48 - 0,60		
110 - 180	0,6 - 1,0	5 - 10	0,46 - 0,58		
130 - 200	0,8 - 1,2	6 - 12	0,52 - 0,60		
120 - 180	0,8 - 1,2	5 - 10	0,46 - 0,56		
400 - 500	2,0 - 2,6	15 - 20	0,64 - 0,78		
340 - 500	1,8 - 2,4	12 - 16	0,62 - 0,7		
300 - 440	1,6 - 2,2	10 - 14	0,58 - 0,68		
180 - 260	1,4 - 2,0	8 - 12	0,56 - 0,68		
280 - 360	1,6 - 2,2	10 - 16	0,6 - 0,68		
210 - 340	1,4 - 2,0	10 - 16	0,58 - 0,66		

Die angegebenen Arbeitswerte sind Richtwerte.  
 Die für den jeweiligen Bearbeitungsfall optimalen Daten sollten im Versuch oder während der Bearbeitung ermittelt werden.

# Schnittwertempfehlung für Trochoidfräser

Vorschub und Schnittgeschwindigkeit

## OptiMill-Tro-H | M3079

MZG*	Werkstoff	Festigkeit/ Härte [N/mm <sup>2</sup> ] [HRC]	Kühlung			v <sub>c</sub> [m/min]	f <sub>z</sub> [mm] in % vom D	a <sub>e</sub> [mm] in % vom D	h <sub>m</sub> max. [mm] in % vom D
			MMS/Luft	Trocken	KSS				
H	H1.1	Gehärteter Stahl/Stahlguss	< 44	✓	✓	<b>100 - 160</b>	0,48 - 0,67	6 - 10	0,38 - 0,50
	H1.2	Gehärteter Stahl/Stahlguss	< 55	✓	✓	<b>80 - 140</b>	0,45 - 0,65	4 - 8	0,28 - 0,36
	H2.1	Gehärteter Stahl/Stahlguss	< 60	✓	✓	<b>60 - 120</b>	0,4 - 0,52	3 - 6	0,27 - 0,34
	H2.2	Gehärteter Stahl/Stahlguss	< 65	✓	✓	<b>50 - 110</b>	0,37 - 0,5	3 - 5	0,26 - 0,33
	H2.3	Gehärteter Stahl/Stahlguss	< 68	✓	✓	<b>50 - 100</b>	0,3 - 0,48	2 - 5	0,25 - 0,32
	H3	H3.1	Verschleißbeständiger Guss/Hartguss, GJN		✓		<b>60 - 120</b>	0,35 - 0,55	3 - 6

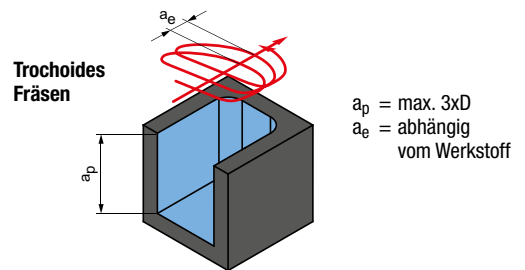

## OptiMill-Tro-S | M3699

## OptiMill-Tro-Titan | M3799

MZG*	Werkstoff	Festigkeit/ Härte [N/mm <sup>2</sup> ] [HRC]	Kühlung			v <sub>c</sub> [m/min]	f <sub>z</sub> [mm] in % vom D	a <sub>e</sub> [mm] in % vom D	h <sub>m</sub> max. [mm] in % vom D
			MMS/Luft	Trocken	KSS				
S	S1.1	Titan, Titanlegierungen	< 400		✓	<b>110 - 170</b>	0,65 - 1,3	6 - 12	0,52 - 0,6
	S2.1	Titan, Titanlegierungen	< 1.200		✓	<b>90 - 150</b>	0,6 - 1,2	5 - 10	0,46 - 0,56
	S2.2	Titan, Titanlegierungen	> 1.200		✓	<b>70 - 130</b>	0,4 - 1,0	5 - 10	0,42 - 0,54
	S3.1	Nickel, unlegiert und legiert	< 900		✓	<b>60 - 120</b>	0,4 - 1,0	5 - 10	0,4 - 0,52
	S3.2	Nickel, unlegiert und legiert	> 900		✓	<b>50 - 100</b>	0,3 - 0,9	5 - 10	0,4 - 0,52
	S4.1	Hochwärmfeste Superlegierung, Ni-, Co-, und Fe-basiert			✓	<b>35 - 90</b>	0,3 - 0,8	4 - 8	0,38 - 0,46
	S5.1	Wolfram- und Molybdänlegierungen			✓	<b>35 - 90</b>	0,3 - 0,8	4 - 8	0,38 - 0,46

### Hinweis:

Beim Trochoidfräsen verändern sich die angegebenen Schnittbedingungen während des Bearbeitungsprozesses. Dies ist auch abhängig von der verwendeten CAM-Software sowie der Bearbeitungsstellung des Werkzeugs im Werkstück. Vorschub und Eingriffsbreite bzw. Eingriffswinkel ändern sich während der Bearbeitung ständig, um je nach Kontur eine möglichst konstante Spanmittendicke zu erzielen.



	Bearbeitungsbeispiel	
	<b>90MnCrV8</b> $\varnothing = 12 \text{ mm}$ $v_c = 110 \text{ m/min}$ $f_z = 0,052 \text{ mm}$ $h_m = 0,04 \text{ mm}$ $a_e = 1 \text{ mm}$	

	Bearbeitungsbeispiel	
	<b>TiAl6V4</b> $\varnothing = 12 \text{ mm}$ $v_c = 140 \text{ m/min}$ $f_z = 0,09 \text{ mm}$ $a_e = 1,2 \text{ mm}$ $a_p = 30 \text{ mm}$	

Die angegebenen Arbeitswerte sind Richtwerte.

Die für den jeweiligen Bearbeitungsfall optimalen Daten sollten im Versuch oder während der Bearbeitung ermittelt werden.

# Schnittwertempfehlung für Trochoidfräser

Vorschub und Schnittgeschwindigkeit

## OptiMill-Tro-Inox I M3399

MZG*	Werkstoff	Festigkeit/Härte [N/mm <sup>2</sup> ] [HRC]	Kühlung		
			MMS/Luft	Trocken	KSS
<b>M</b>	M1.1	Rostfreie Stähle, austenitisch	< 700	✓	✓
	M1.2	Rostfreie Stähle, ferritisch/austenitisch (Duplex)	< 1.000		✓
	M2.1	Rostfreier Stahlguss, austenitisch	< 700	✓	✓
	M3.1	Rostfreier Stahlguss, ferritisch/austenitisch (Duplex)	< 1.000		✓

## Korrekturfaktor Werkzeuglänge - $k_{WL}$

Faktor	$v_c$	$a_e$	$h_m$
	<b>M</b>		
2xD	1,05	1,05	1,05
3xD	1,00	1,00	1,00
4xD	0,92	0,90	0,94
5xD	0,80	0,80	0,87

### Hinweis:

Für die Ermittlung der Schnittwerte bitte die Hinweise auf den Seiten 520-523 beachten.

### Hinweis:

Beim Trochoidfräsen verändern sich die angegebenen Schnittbedingungen während des Bearbeitungsprozesses. Dies ist auch abhängig von der verwendeten CAM-Software sowie der Bearbeitungsstellung des Werkzeugs im Werkstück. Vorschub und Eingriffsbreite bzw. Eingriffswinkel ändern sich während der Bearbeitung ständig, um je nach Kontur eine möglichst konstante Spanmittendicke zu erzielen.

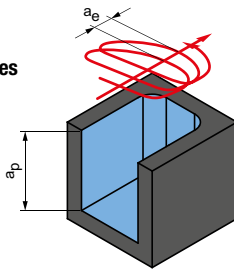
Trochoides  
Fräsen

$a_p$  = abhängig von der Werkzeuglänge  
 $a_e$  = abhängig vom Werkstoff

$v_c$ [m/min]	$f_z$ [mm] in % vom D	$a_e$ [mm] in % vom D	$h_m$ max. [mm] in % vom D	Bearbeitungsbeispiel
160 - 220	0,8 - 1,1	5-10	0,48 - 0,60	<b>X5CrNi18-8</b> $\emptyset = 12$ mm $v_c = 180$ m/min $f_z = 0,09$ mm $a_e = 1,2$ mm $a_p = 32$ mm
120 - 160	0,6 - 1,0	5-10	0,46 - 0,58	
160 - 220	0,8 - 1,1	5-10	0,48 - 0,60	
120 - 160	0,6 - 1,0	5-10	0,46 - 0,58	

Die angegebenen Arbeitswerte sind Richtwerte.

Die für den jeweiligen Bearbeitungsfall optimalen Daten sollten im Versuch oder während der Bearbeitung ermittelt werden.



# KUGEL- UND ECKRADIUSFRÄSER

## Universeller Einsatz

---

OptiMill-3D-BN .....	446
OptiMill-3D-CR .....	454

## Gehärteter Stahl

---

OptiMill-3D-BN-Hardened .....	448
OptiMill-3D-CR-Hardened .....	460

## Nichteisenmetalle

---

OptiMill-3D-BN-Alu .....	450
OptiMill-3D-CR-Alu .....	466

## Kunststoffe und Verbundwerkstoffe

---

OptiMill-Composite-Speed-Radius .....	467
---------------------------------------	-----

## Technischer Anhang

---

Schnittwertempfehlung .....	468
-----------------------------	-----

# OptiMill®-3D-BN

Kugelfräser, Ausführung mit Hals, z=2  
TBN101

**Ausführung:**

Fräserdurchmesser: 1,00 - 12,00 mm  
 Schneidstoff: HP801/HP820  
 Schneidzahl: 2  
 Spiralwinkel: 28°  
 Toleranz Radiuskontur: ±0,005 wenn d<sub>1</sub> ≤ 6 mm  
 ±0,01 wenn d<sub>1</sub> > 6 mm

**Anwendung:**

Geeignet zur Bearbeitung von Werkstoffen bis 55 HRC.

**Schaftübergang:**

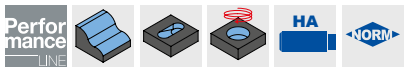
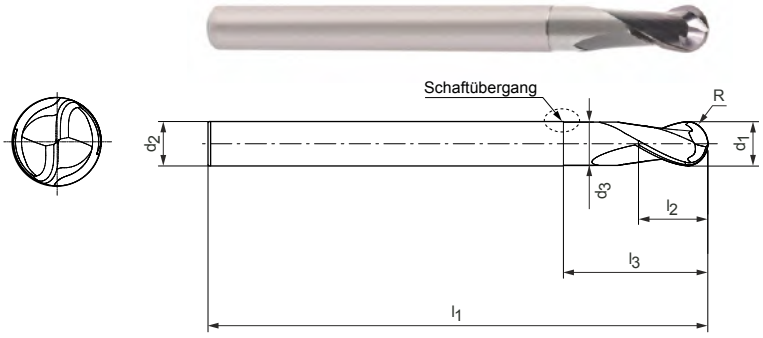
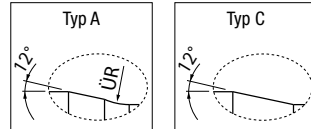

**Lagerhaltige Vorzugsbaureihe**

Baumaße					Arbeitstiefe bei x° Formschräge				Typ	Spezifikation	Bestell-Nr.		
d <sub>1</sub>	R	l <sub>3</sub>	d <sub>2</sub> h5	l <sub>1</sub>	l <sub>2</sub>	d <sub>3</sub>	0,5°	1°				1,5°	3°
1,00	0,5	3	4	50	1,2	0,94	3,47	3,57	3,66	4,01	A	TBN101-010-0050-0300X050-HP820	31157173
1,00	0,5	5	4	50	1,2	0,94	5,54	5,68	5,8	6,66	A	TBN101-010-0050-0500X050-HP820	31157175
2,00	1	8	4	50	2,3	1,94	9,09	9,45	9,74	10,49	A	TBN101-020-0100-0800X050-HP801	31157194
2,50	1,25	25	6	75	2,9	2,44	26,72	27,37	28,5	32,97	A	TBN101-025-0125-2500X075-HP801	31157209
3,00	1,5	10	6	60	3,5	2,94	11,17	11,56	11,88	12,98	A	TBN101-030-0150-1000X060-HP801	31157210
3,00	1,5	15	6	60	3,5	2,94	16,38	16,87	17,26	19,62	A	TBN101-030-0150-1500X060-HP801	31157211
3,00	1,5	20	6	60	3,5	2,94	21,56	22,13	22,76	26,25	A	TBN101-030-0150-2000X060-HP801	31157212
3,00	1,5	25	6	75	3,5	2,94	26,71	27,36	28,47	32,2	A	TBN101-030-0150-2500X075-HP801	31157213
4,00	2	10	6	60	4,6	3,94	11,14	11,52	11,84	12,82	A	TBN101-040-0200-1000X060-HP801	31157214
4,00	2	15	6	60	4,6	3,94	16,36	16,84	17,23	19,46	A	TBN101-040-0200-1500X060-HP801	31157215
4,00	2	20	6	60	4,6	3,94	21,54	22,1	22,69	24,85	A	TBN101-040-0200-2000X060-HP801	31157216
4,00	2	25	6	75	4,6	3,94	26,7	27,33	28,4	29,85	A	TBN101-040-0200-2500X075-HP801	31157217
4,00	2	30	6	75	4,6	3,94	31,84	32,66	34,1	34,85	A	TBN101-040-0200-3000X075-HP801	31157218
4,00	2	35	6	75	4,6	3,94	36,98	38,11	39,8	39,85	A	TBN101-040-0200-3500X075-HP801	31157219
5,00	2,5	15	6	60	5,8	4,9	15,78	16,38	17,03	17,59	C	TBN101-050-0250-1500X060-HP801	31157220
5,00	2,5	20	6	60	5,8	4,9	21	21,82	22,59	-	C	TBN101-050-0250-2000X060-HP801	31157221
5,00	2,5	25	6	60	5,8	4,9	26,21	27,27	27,59	-	C	TBN101-050-0250-2500X060-HP801	31157222
5,00	2,5	30	6	75	5,8	4,9	31,42	32,59	-	-	C	TBN101-050-0250-3000X075-HP801	31157223
6,00	3	15	6	60	6,9	5,9	-	-	-	-	-	TBN101-060-0300-1500X060-HP801	31157224
6,00	3	20	6	60	6,9	5,9	-	-	-	-	-	TBN101-060-0300-2000X060-HP801	31157225
6,00	3	25	6	60	6,9	5,9	-	-	-	-	-	TBN101-060-0300-2500X060-HP801	31157226
6,00	3	30	6	75	6,9	5,9	-	-	-	-	-	TBN101-060-0300-3000X075-HP801	31157227
6,00	3	35	6	75	6,9	5,9	-	-	-	-	-	TBN101-060-0300-3500X075-HP801	31157228
8,00	4	25	8	64	9,2	7,8	-	-	-	-	-	TBN101-080-0400-2500X064-HP801	31157229
8,00	4	50	8	100	9,2	7,8	-	-	-	-	-	TBN101-080-0400-5000X100-HP801	31157230
10,00	5	30	10	75	11,5	9,8	-	-	-	-	-	TBN101-100-0500-3000X075-HP801	31157231
10,00	5	50	10	100	11,5	9,8	-	-	-	-	-	TBN101-100-0500-5000X100-HP801	31157232
12,00	6	35	12	75	13,8	11,8	-	-	-	-	-	TBN101-120-0600-3500X075-HP801	31157233
12,00	6	60	12	100	13,8	11,8	-	-	-	-	-	TBN101-120-0600-6000X100-HP801	31157234

Maßangaben in mm.  
 Schnittwertempfehlung siehe Kapitelende.  
 Sonderausführungen und andere Beschichtungen auf Anfrage.

# OptiMill®-3D-BN

Kugelfräser, Ausführung mit Hals, z=4  
TBN104

**Ausführung:**

Fräserdurchmesser: 3,00 - 12,00 mm  
 Schneidstoff: HP801  
 Schneidzahl: 4  
 Spiralwinkel: 30°  
 Toleranz Radiuskontur: ±0,005 wenn d<sub>1</sub> ≤ 6 mm  
 ±0,01 wenn d<sub>1</sub> > 6 mm

**Anwendung:**

Geeignet zur Bearbeitung von Werkstoffen bis 55 HRC.

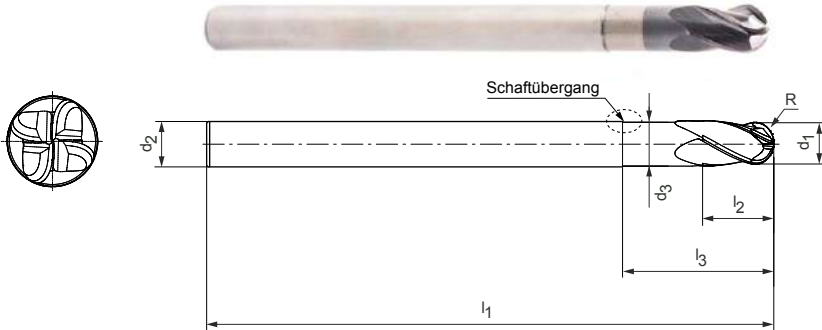

**Schaftübergang:**

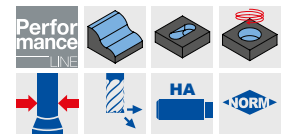
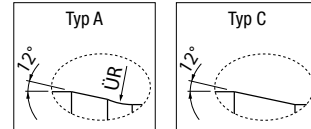

**Lagerhaltige Vorzugsbaureihe**

Baumaße						Arbeitstiefe bei x° Formschräge				Typ	Spezifikation	Bestell-Nr.	
d <sub>1</sub>	R	l <sub>3</sub>	d <sub>2</sub> h5	l <sub>1</sub>	l <sub>2</sub>	d <sub>3</sub>	0,5°	1°	1,5°				3°
3,00	1,5	10	6	60	3,5	2,94	11,17	11,56	11,88	12,98	A	TBN104-030-0150-1000X060-HP801	31157406
3,00	1,5	15	6	60	3,5	2,94	16,38	16,87	17,26	19,62	A	TBN104-030-0150-1500X060-HP801	31157407
3,00	1,5	20	6	60	3,5	2,94	21,56	22,13	22,76	26,25	A	TBN104-030-0150-2000X060-HP801	31157408
3,00	1,5	25	6	75	3,5	2,94	26,71	27,36	28,47	32,20	A	TBN104-030-0150-2500X075-HP801	31157409
4,00	2	10	6	60	4,6	3,94	11,14	11,52	11,84	12,82	A	TBN104-040-0200-1000X060-HP801	31157410
4,00	2	15	6	60	4,6	3,94	16,36	16,84	17,23	19,46	A	TBN104-040-0200-1500X060-HP801	31157411
4,00	2	20	6	60	4,6	3,94	21,54	22,10	22,69	24,85	A	TBN104-040-0200-2000X060-HP801	31157412
4,00	2	25	6	75	4,6	3,94	26,70	27,33	28,40	29,85	A	TBN104-040-0200-2500X075-HP801	31157413
4,00	2	30	6	75	4,6	3,94	31,84	32,66	34,10	34,85	A	TBN104-040-0200-3000X075-HP801	31157414
5,00	2,5	20	6	60	5,8	4,9	21,00	21,82	22,59	-	C	TBN104-050-0250-2000X060-HP801	31157416
5,00	2,5	30	6	75	5,8	4,9	31,42	32,59	-	-	C	TBN104-050-0250-3000X075-HP801	31157418
6,00	3	15	6	60	6,9	5,9	-	-	-	-	-	TBN104-060-0300-1500X060-HP801	31157419
6,00	3	20	6	60	6,9	5,9	-	-	-	-	-	TBN104-060-0300-2000X060-HP801	31157420
6,00	3	25	6	60	6,9	5,9	-	-	-	-	-	TBN104-060-0300-2500X060-HP801	31157421
6,00	3	30	6	75	6,9	5,9	-	-	-	-	-	TBN104-060-0300-3000X075-HP801	31157422
6,00	3	35	6	75	6,9	5,9	-	-	-	-	-	TBN104-060-0300-3500X075-HP801	31157423
8,00	4	25	8	64	9,2	7,8	-	-	-	-	-	TBN104-080-0400-2500X064-HP801	31157424
8,00	4	50	8	100	9,2	7,8	-	-	-	-	-	TBN104-080-0400-5000X100-HP801	31157425
10,00	5	30	10	75	11,5	9,8	-	-	-	-	-	TBN104-100-0500-3000X075-HP801	31157426
10,00	5	50	10	100	11,5	9,8	-	-	-	-	-	TBN104-100-0500-5000X100-HP801	31157427
12,00	6	35	12	75	13,8	11,8	-	-	-	-	-	TBN104-120-0600-3500X075-HP801	31157428
12,00	6	60	12	100	13,8	11,8	-	-	-	-	-	TBN104-120-0600-6000X100-HP801	31157429

**Auf Anfrage erhältlich**

5,00	2,5	15	6	60	5,8	4,9	15,78	16,38	17,03	17,59	C	TBN104-050-0250-1500X060-HP801	31157415
5,00	2,5	25	6	60	5,8	4,9	26,21	27,27	27,59	-	C	TBN104-050-0250-2500X060-HP801	31157417

Maßangaben in mm.  
 Schnittwertempfehlung siehe Kapitelende.  
 Sonderausführungen und andere Beschichtungen auf Anfrage.

**Anwendungshinweis**

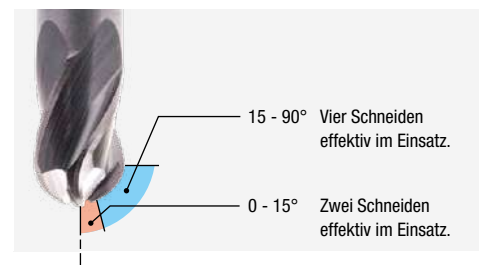

# OptiMill®-3D-BN-Hardened

Kugelfräser, Ausführung mit Hals, z=2  
TBN107

**Ausführung:**

Fräserdurchmesser: 3,00 - 12,00 mm  
 Schneidstoff: HP808/HP818  
 Schneidzahl: 2  
 Spiralwinkel: 30°  
 Toleranz Radiuskontur: ±0,005 wenn d<sub>1</sub> ≤ 6 mm  
 ±0,01 wenn d<sub>1</sub> > 6 mm

**Anwendung:**

Geeignet zur Bearbeitung von Werkstoffen bis 68 HRC.

**Schaftübergang:**

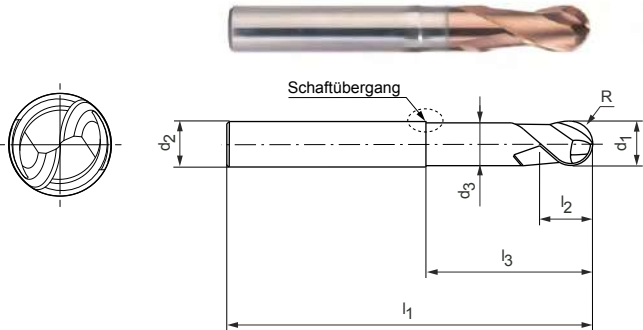
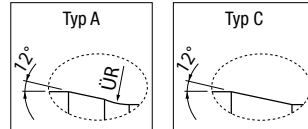

**Lagerhaltige Vorzugsbaureihe**

Baumaße						Arbeitstiefe bei x° Formschräge				Typ	Schaftform HA	Bestell-Nr.	
d <sub>1</sub>	R	l <sub>3</sub>	d <sub>2</sub> h <sub>5</sub>	l <sub>1</sub>	l <sub>2</sub>	d <sub>3</sub>	0,5°	1°	1,5°		3°		Spezifikation
3,00	1,5	10	6	60	3,5	2,94	11,17	11,56	11,88	12,98	A	TBN107-030-0150-1000X060-HP808	31167031
3,00	1,5	15	6	60	3,5	2,94	16,38	16,87	17,26	19,62	A	TBN107-030-0150-1500X060-HP808	31167032
3,00	1,5	20	6	60	3,5	2,94	21,56	22,13	22,76	26,25	A	TBN107-030-0150-2000X060-HP808	31167033
3,00	1,5	25	6	75	3,5	2,94	26,71	27,36	28,47	32,2	A	TBN107-030-0150-2500X075-HP808	31167034
4,00	2	10	6	60	4,6	3,94	11,14	11,52	11,84	12,82	A	TBN107-040-0200-1000X060-HP808	31167035
4,00	2	15	6	60	4,6	3,94	16,36	16,84	17,23	19,46	A	TBN107-040-0200-1500X060-HP808	31167036
4,00	2	20	6	60	4,6	3,94	21,54	22,1	22,69	24,85	A	TBN107-040-0200-2000X060-HP808	31167037
4,00	2	25	6	75	4,6	3,94	26,7	27,33	28,4	29,85	A	TBN107-040-0200-2500X075-HP808	31167038
4,00	2	30	6	75	4,6	3,94	31,84	32,66	34,1	34,85	A	TBN107-040-0200-3000X075-HP808	31167039
4,00	2	35	6	75	4,6	3,94	36,98	38,11	39,8	39,85	A	TBN107-040-0200-3500X075-HP808	31167040
5,00	2,5	15	6	60	5,8	4,9	15,78	16,38	17,03	17,59	C	TBN107-050-0250-1500X060-HP808	31167041
5,00	2,5	20	6	60	5,8	4,9	21	21,82	22,59	-	C	TBN107-050-0250-2000X060-HP808	31167042
5,00	2,5	25	6	60	5,8	4,9	26,21	27,27	27,59	-	C	TBN107-050-0250-2500X060-HP808	31167043
5,00	2,5	30	6	75	5,8	4,9	31,42	32,59	-	-	C	TBN107-050-0250-3000X075-HP808	31167044
6,00	3	15	6	60	6,9	5,9	-	-	-	-	-	TBN107-060-0300-1500X060-HP808	31167045
6,00	3	20	6	60	6,9	5,9	-	-	-	-	-	TBN107-060-0300-2000X060-HP808	31167046
6,00	3	25	6	60	6,9	5,9	-	-	-	-	-	TBN107-060-0300-2500X060-HP808	31167047
6,00	3	30	6	75	6,9	5,9	-	-	-	-	-	TBN107-060-0300-3000X075-HP808	31167048
6,00	3	35	6	75	6,9	5,9	-	-	-	-	-	TBN107-060-0300-3500X075-HP808	31167049
8,00	4	25	8	64	9,2	7,8	-	-	-	-	-	TBN107-080-0400-2500X064-HP808	31167050
8,00	4	50	8	100	9,2	7,8	-	-	-	-	-	TBN107-080-0400-5000X100-HP808	31167051
10,00	5	30	10	75	11,5	9,8	-	-	-	-	-	TBN107-100-0500-3000X075-HP808	31167052
10,00	5	50	10	100	11,5	9,8	-	-	-	-	-	TBN107-100-0500-5000X100-HP808	31167053
12,00	6	35	12	75	13,8	11,8	-	-	-	-	-	TBN107-120-0600-3500X075-HP808	31167054
12,00	6	60	12	100	13,8	11,8	-	-	-	-	-	TBN107-120-0600-6000X100-HP808	31167055

**Konfigurierbare Merkmale**

**Schaftform:**  
Schaftform: HB

Maßangaben in mm.  
 Schnittwertempfehlung siehe Kapitelende.  
 Sonderausführungen und andere Beschichtungen auf Anfrage.



# OptiMill®-3D-BN-Hardened

Kugelfräser, Ausführung mit Hals, z=4  
TBN109

**Ausführung:**  
Fräserdurchmesser: 3,00 - 12,00 mm  
Schneidstoff: HP808  
Schneidzahl: 4  
Spiralwinkel: 35°  
Toleranz Radiuskontur: ±0,005 wenn d<sub>1</sub> ≤ 6 mm  
±0,01 wenn d<sub>1</sub> > 6 mm

**Anwendung:**  
Geeignet zur Bearbeitung von Werkstoffen bis 68 HRC.

**Schaftübergang:**

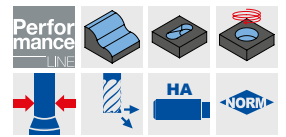
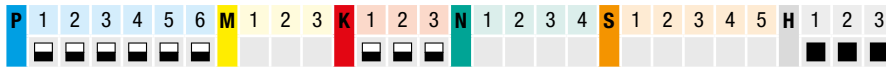
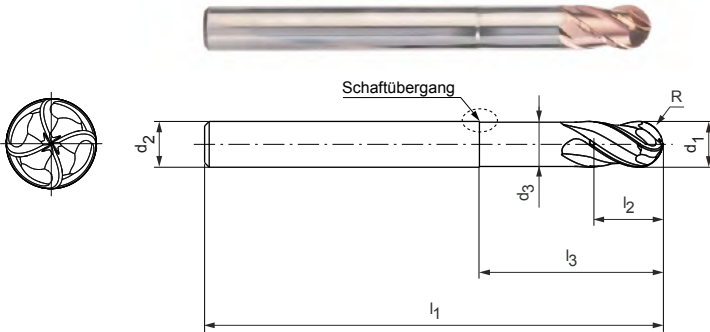
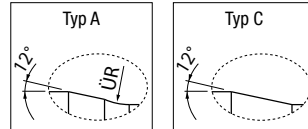

**Lagerhaltige Vorzugsbaureihe**

Baumaße							Arbeitstiefe bei x° Formschräge				Typ	Spezifikation	Bestell-Nr.
d <sub>1</sub>	R	l <sub>3</sub>	d <sub>2</sub> h5	l <sub>1</sub>	l <sub>2</sub>	d <sub>3</sub>	0,5°	1°	1,5°	3°			
3,00	1,5	10	6	60	3,5	2,94	11,17	11,56	11,88	12,98	A	TBN109-030-0150-1000X060-HP808	31167068
3,00	1,5	15	6	60	3,5	2,94	16,38	16,87	17,26	19,62	A	TBN109-030-0150-1500X060-HP808	31167069
3,00	1,5	20	6	60	3,5	2,94	21,56	22,13	22,76	26,25	A	TBN109-030-0150-2000X060-HP808	31167070
3,00	1,5	25	6	75	3,5	2,94	26,71	27,36	28,47	32,20	A	TBN109-030-0150-2500X075-HP808	31167071
4,00	2	10	6	60	4,6	3,94	11,14	11,52	11,84	12,82	A	TBN109-040-0200-1000X060-HP808	31167072
4,00	2	15	6	60	4,6	3,94	16,36	16,84	17,23	19,46	A	TBN109-040-0200-1500X060-HP808	31167073
4,00	2	20	6	60	4,6	3,94	21,54	22,10	22,69	24,85	A	TBN109-040-0200-2000X060-HP808	31167074
4,00	2	25	6	75	4,6	3,94	26,70	27,33	28,40	29,85	A	TBN109-040-0200-2500X075-HP808	31167075
4,00	2	30	6	75	4,6	3,94	31,84	32,66	34,10	34,85	A	TBN109-040-0200-3000X075-HP808	31167076
5,00	2,5	20	6	60	5,8	4,9	21,00	21,82	22,59	-	C	TBN109-050-0250-2000X060-HP808	31167078
5,00	2,5	30	6	75	5,8	4,9	31,42	32,59	-	-	C	TBN109-050-0250-3000X075-HP808	31167080
6,00	3	15	6	60	6,9	5,9	-	-	-	-	-	TBN109-060-0300-1500X060-HP808	31167081
6,00	3	20	6	60	6,9	5,9	-	-	-	-	-	TBN109-060-0300-2000X060-HP808	31167082
6,00	3	25	6	60	6,9	5,9	-	-	-	-	-	TBN109-060-0300-2500X060-HP808	31167083
6,00	3	30	6	75	6,9	5,9	-	-	-	-	-	TBN109-060-0300-3000X075-HP808	31167084
6,00	3	35	6	75	6,9	5,9	-	-	-	-	-	TBN109-060-0300-3500X075-HP808	31167085
8,00	4	25	8	64	9,2	7,8	-	-	-	-	-	TBN109-080-0400-2500X064-HP808	31167086
8,00	4	50	8	100	9,2	7,8	-	-	-	-	-	TBN109-080-0400-5000X100-HP808	31167087
10,00	5	30	10	75	11,5	9,8	-	-	-	-	-	TBN109-100-0500-3000X075-HP808	31167088
10,00	5	50	10	100	11,5	9,8	-	-	-	-	-	TBN109-100-0500-5000X100-HP808	31167089
12,00	6	35	12	75	13,8	11,8	-	-	-	-	-	TBN109-120-0600-3500X075-HP808	31167090
12,00	6	60	12	100	13,8	11,8	-	-	-	-	-	TBN109-120-0600-6000X100-HP808	31167091

**Auf Anfrage erhältlich**

5,00	2,5	15	6	60	5,8	4,9	15,78	16,38	17,03	17,59	C	TBN109-050-0250-1500X060-HP808	31167077
5,00	2,5	25	6	60	5,8	4,9	26,21	27,27	27,59	-	C	TBN109-050-0250-2500X060-HP808	31167079

Maßangaben in mm.  
Schnittwertempfehlung siehe Kapitelende.  
Sonderausführungen und andere Beschichtungen auf Anfrage.

# OptiMill®-3D-BN-Alu

Kugelfräser, kurze Ausführung, z=2  
TBN114

## Ausführung:

Fräserdurchmesser: 1,00 - 20,00 mm  
Schneidstoff: HP807/HU644  
Schneidenzahl: 2  
Spiralwinkel: 30°  
Toleranz Radiuskontur: R = ±0,01

## Anwendung:

Geeignet zur Bearbeitung von hochfesten Aluminiumlegierungen.

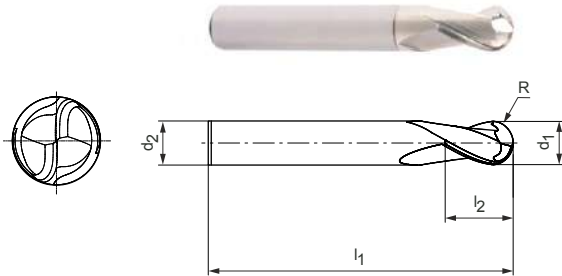

### Lagerhaltige Vorzugsbaureihe

Baumaße					z	Spezifikation	Bestell-Nr.
d <sub>1</sub>	R	d <sub>2</sub> h5	l <sub>1</sub>	l <sub>2</sub>			
1,00	0,5	4	50	1,5	2	TBN114-010-0050-X050-HU644	31155217
1,50	0,75	4	50	2,5	2	TBN114-015-0075-X050-HU644	31155218
2,00	1	6	57	3	2	TBN114-020-0100-X057-HP807	31155219
2,00	1	4	50	3	2	TBN114-020-0100-X050-HP807	31155220
3,00	1,5	6	57	4,5	2	TBN114-030-0150-X057-HP807	31155221
4,00	2	6	57	6	2	TBN114-040-0200-X057-HP807	31155222
5,00	2,5	6	57	7,5	2	TBN114-050-0250-X057-HP807	31155223
6,00	3	6	57	9	2	TBN114-060-0300-X057-HP807	31155224
8,00	4	8	63	16	2	TBN114-080-0400-X063-HP807	31155225
10,00	5	10	72	15	2	TBN114-100-0500-X072-HP807	31155226
12,00	6	12	83	18	2	TBN114-120-0600-X083-HP807	31155227
16,00	8	16	92	24	2	TBN114-160-0800-X092-HP807	31155228
20,00	10	20	104	30	2	TBN114-200-1000-X104-HP807	31155229

Maßangaben in mm.

Schnittwertempfehlung siehe Kapitelende.

Sonderausführungen und andere Beschichtungen auf Anfrage.

# OptiMill®-3D-BN-Alu

Kugelfräser, Ausführung mit Hals, z=2  
TBN116

**Ausführung:**  
Fräserdurchmesser: 1,00 - 20,00 mm  
Schneidstoff: HP807/HU644  
Schneidenzahl: 2  
Spiralwinkel: 30°  
Toleranz Radiuskontur: R = ±0,01

**Anwendung:**  
Geeignet zur Bearbeitung von hochfesten Aluminiumlegierungen.

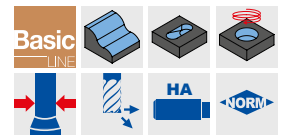
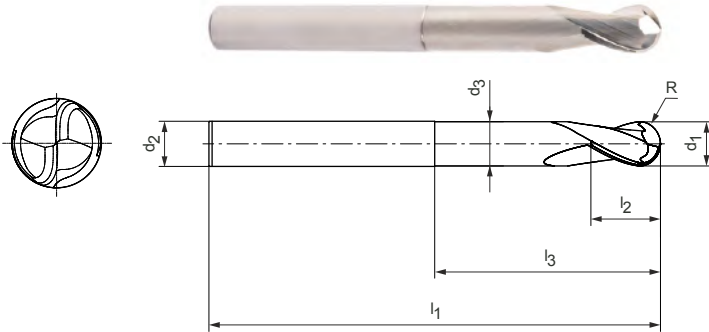

## Lagerhaltige Vorzugsbaureihe

Baumaße							z	Spezifikation	Bestell-Nr.
d <sub>1</sub>	R	l <sub>3</sub>	d <sub>2</sub> h5	l <sub>1</sub>	l <sub>2</sub>	d <sub>3</sub>			
1,00	0,5	6	4	50	1,5	0,95	2	TBN116-010-0050-0600X050-HU644	31155248
1,00	0,5	10	4	50	1,5	0,95	2	TBN116-010-0050-1000X050-HU644	31155249
1,00	0,5	15	4	50	1,5	0,95	2	TBN116-010-0050-1500X050-HU644	31155250
1,00	0,5	20	4	75	1,5	0,95	2	TBN116-010-0050-2000X075-HU644	31155251
1,00	0,5	25	4	75	1,5	0,95	2	TBN116-010-0050-2500X075-HU644	31155252
1,00	0,5	30	4	75	1,5	0,95	2	TBN116-010-0050-3000X075-HU644	31155253
1,50	0,75	10	4	50	2,5	1,4	2	TBN116-015-0075-1000X050-HU644	31155254
1,50	0,75	15	4	50	2,5	1,4	2	TBN116-015-0075-1500X050-HU644	31155255
1,50	0,75	20	4	75	2,5	1,4	2	TBN116-015-0075-2000X075-HU644	31155256
1,50	0,75	25	4	75	2,5	1,4	2	TBN116-015-0075-2500X075-HU644	31155257
1,50	0,75	30	4	75	2,5	1,4	2	TBN116-015-0075-3000X075-HU644	31155258
2,00	1	10	4	50	3	1,9	2	TBN116-020-0100-1000X050-HP807	31155259
2,00	1	15	4	50	3	1,9	2	TBN116-020-0100-1500X050-HP807	31155260
2,00	1	20	4	75	3	1,9	2	TBN116-020-0100-2000X075-HP807	31155261
2,00	1	25	4	75	3	1,9	2	TBN116-020-0100-2500X075-HP807	31155262
2,00	1	30	4	75	3	1,9	2	TBN116-020-0100-3000X075-HP807	31155263
2,00	1	35	4	75	3	1,9	2	TBN116-020-0100-3500X075-HP807	31155264
3,00	1,5	10	6	57	4,5	2,9	2	TBN116-025-0125-3500X075-HP807	31155267
3,00	1,5	20	6	57	4,5	2,9	2	TBN116-030-0150-2000X057-HP807	31155269
3,00	1,5	30	6	75	4,5	2,9	2	TBN116-030-0150-3000X075-HP807	31155270
3,00	1,5	40	6	75	4,5	2,9	2	TBN116-030-0150-4000X075-HP807	31155271
4,00	2	10	6	57	6	3,8	2	TBN116-040-0200-1000X057-HP807	31155272
4,00	2	20	6	57	6	3,8	2	TBN116-040-0200-2000X057-HP807	31155273
4,00	2	30	6	75	6	3,8	2	TBN116-040-0200-3000X075-HP807	31155274
4,00	2	40	6	75	6	3,8	2	TBN116-040-0200-4000X075-HP807	31155275
6,00	3	20	6	57	9	5,8	2	TBN116-060-0300-2000X057-HP807	31155276
6,00	3	30	6	75	9	5,8	2	TBN116-060-0300-3000X075-HP807	31155277
6,00	3	40	6	75	9	5,8	2	TBN116-060-0300-4000X075-HP807	31155278
6,00	3	50	6	100	9	5,8	2	TBN116-060-0300-5000X100-HP807	31155279
8,00	4	35	8	90	12	7,8	2	TBN116-080-0400-3500X090-HP807	31155281
8,00	4	50	8	100	12	7,8	2	TBN116-080-0400-5000X100-HP807	31155282
10,00	5	40	10	72	15	9,8	2	TBN116-100-0500-4000X072-HP807	31155284
10,00	5	50	10	100	15	9,8	2	TBN116-100-0500-5000X100-HP807	31155285
12,00	6	40	12	83	18	11,8	2	TBN116-120-0600-4000X083-HP807	31155288
12,00	6	50	12	110	18	11,8	2	TBN116-120-0600-5000X110-HP807	31155289

**OptiMill®-3D-BN-Alu | TBN116 | Kugelfräser, Ausführung mit Hals, z=2**

Baumaße							z	Spezifikation	Bestell-Nr.
d <sub>1</sub>	R	l <sub>3</sub>	d <sub>2</sub> h5	l <sub>1</sub>	l <sub>2</sub>	d <sub>3</sub>			
16,00	8	100	16	150	24	15,8	2	TBN116-160-0800-1000X150-HP807	31155292
20,00	10	100	20	150	30	19,8	2	TBN116-200-1000-1000X150-HP807	31155293

**Auf Anfrage erhältlich**

2,50	1,25	15	4	50	4	2,4	2	TBN116-025-0125-1500X050-HP807	31155265
2,50	1,25	20	4	75	4	2,4	2	TBN116-025-0125-2000X075-HP807	31155266
2,50	1,25	35	4	75	4	2,4	2	TBN116-025-0125-3500X075-HP807	31155267
6,00	3	70	6	100	9	5,8	2	TBN116-060-0300-7000X100-HP807	31155280
8,00	4	70	8	100	12	7,8	2	TBN116-080-0400-7000X100-HP807	31155283
10,00	5	70	10	100	15	9,8	2	TBN116-100-0500-7000X100-HP807	31155286
10,00	5	100	10	150	15	9,8	2	TBN116-100-0500-1000X150-HP807	31155287
12,00	6	70	12	110	18	11,8	2	TBN116-120-0600-7000X110-HP807	31155290
12,00	6	100	12	150	18	11,8	2	TBN116-120-0600-1000X150-HP807	31155291

Maßangaben in mm.

Schnittwertempfehlung siehe Kapitelende.

Sonderausführungen und andere Beschichtungen auf Anfrage.

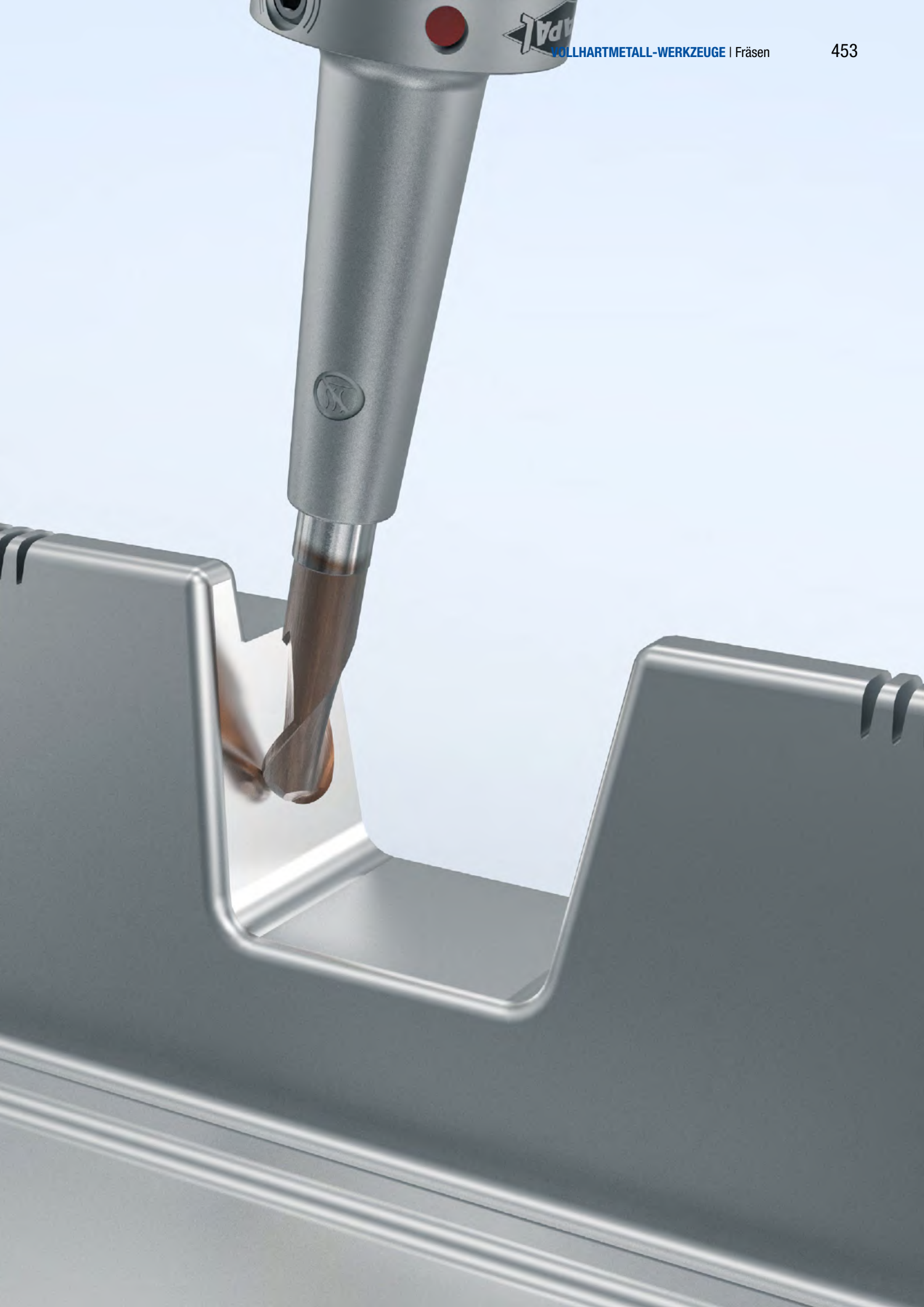

# OptiMill®-3D-CR

Eckradiusfräser, Ausführung mit Hals, z=2  
TCR101

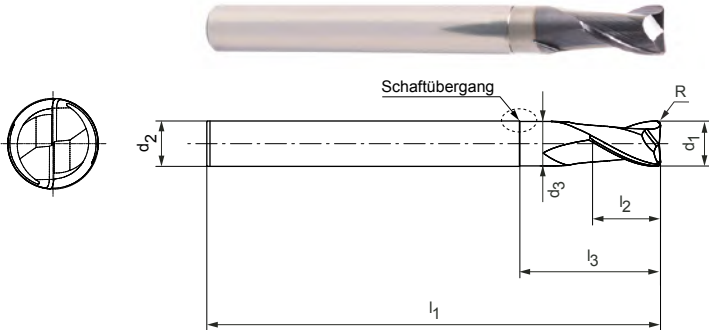

**Ausführung:**

Fräserdurchmesser: 0,40 - 12,00 mm  
 Schneidstoff: HP803/HP819/HP825  
 Schneidzahl: 2  
 Spiralwinkel: 30°  
 Toleranz Radiuskontur: ±0,005 wenn d<sub>1</sub> ≤ 6 mm  
 ±0,01 wenn d<sub>1</sub> > 6 mm

**Anwendung:**

Geeignet zur Bearbeitung von Werkstoffen bis 55 HRC.

**Schaftübergang:**

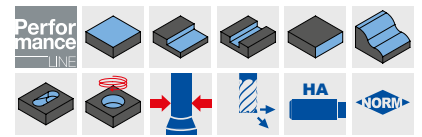
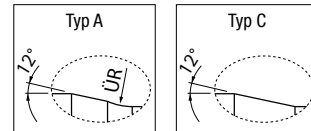

**Lagerhaltige Vorzugsbaureihe**

Baumaße					Arbeitstiefe bei x° Formschräge				Typ	Spezifikation	Bestell-Nr.		
d <sub>1</sub>	R	l <sub>3</sub>	d <sub>2</sub> h5	l <sub>1</sub>	l <sub>2</sub>	d <sub>3</sub>	0,5°	1°				1,5°	3°
0,40	0,1	0,75	4	50	0,5	0,37	1,05	1,11	1,16	1,30	A	TCR101-004-0010-0075X050-HP825	31167141
0,40	0,1	1	4	50	0,5	0,37	1,32	1,39	1,45	1,61	A	TCR101-004-0010-0100X050-HP825	31167142
0,40	0,1	1,5	4	50	0,5	0,37	1,85	1,93	2,01	2,20	A	TCR101-004-0010-0150X050-HP825	31167143
0,40	0,1	2	4	50	0,5	0,37	2,37	2,47	2,56	2,77	A	TCR101-004-0010-0200X050-HP825	31167144
0,40	0,1	2	6	60	0,5	0,37	2,37	2,47	2,56	2,77	A	TCR101-004-0010-0200X060-HP825	31167145
0,40	0,1	3	6	60	0,5	0,37	3,42	3,54	3,65	4,04	A	TCR101-004-0010-0300X060-HP825	31167146
0,50	0,1	1,5	4	50	0,6	0,46	1,88	1,95	2,03	2,21	A	TCR101-005-0010-0150X050-HP825	31167147
0,50	0,1	2	4	50	0,6	0,46	2,40	2,49	2,58	2,79	A	TCR101-005-0010-0200X050-HP825	31167148
0,50	0,1	3	4	50	0,6	0,46	3,44	3,56	3,66	4,07	A	TCR101-005-0010-0300X050-HP825	31167149
0,50	0,1	4	4	50	0,6	0,46	4,48	4,62	4,74	5,40	A	TCR101-005-0010-0400X050-HP825	31167150
0,50	0,1	4	6	60	0,6	0,46	4,48	4,62	4,74	5,40	A	TCR101-005-0010-0400X060-HP825	31167151
0,50	0,1	5	4	50	0,6	0,46	5,51	5,67	5,81	6,73	A	TCR101-005-0010-0500X050-HP825	31167152
0,50	0,1	6	4	50	0,6	0,46	6,55	6,72	6,94	8,06	A	TCR101-005-0010-0600X050-HP825	31167153
0,50	0,1	6	6	60	0,6	0,46	6,55	6,72	6,94	8,06	A	TCR101-005-0010-0600X060-HP825	31167154
0,60	0,1	2	4	50	0,7	0,56	2,40	2,49	2,58	2,79	A	TCR101-006-0010-0200X050-HP825	31167155
0,60	0,1	3	4	50	0,7	0,56	3,44	3,56	3,66	4,07	A	TCR101-006-0010-0300X050-HP825	31167156
0,60	0,1	4	4	50	0,7	0,56	4,48	4,62	4,74	5,40	A	TCR101-006-0010-0400X050-HP825	31167157
0,60	0,1	4	6	60	0,7	0,56	4,48	4,62	4,74	5,40	A	TCR101-006-0010-0400X060-HP825	31167158
0,60	0,1	5	4	50	0,7	0,56	5,51	5,67	5,81	6,73	A	TCR101-006-0010-0500X050-HP825	31167159
0,60	0,1	6	4	50	0,7	0,56	6,55	6,72	6,94	8,06	A	TCR101-006-0010-0600X050-HP825	31167160
0,60	0,1	6	6	60	0,7	0,56	6,55	6,72	6,94	8,06	A	TCR101-006-0010-0600X060-HP825	31167161
0,60	0,1	8	6	60	0,7	0,56	8,61	8,81	9,22	10,71	A	TCR101-006-0010-0800X060-HP825	31167162
0,80	0,1	3	4	50	0,9	0,76	3,44	3,56	3,66	4,07	A	TCR101-008-0010-0300X050-HP825	31167163
0,80	0,1	4	4	50	0,9	0,76	4,48	4,62	4,74	5,40	A	TCR101-008-0010-0400X050-HP825	31167164
0,80	0,1	6	4	50	0,9	0,76	6,55	6,72	6,94	8,06	A	TCR101-008-0010-0600X050-HP825	31167165
0,80	0,1	6	6	60	0,9	0,76	6,55	6,72	6,94	8,06	A	TCR101-008-0010-0600X060-HP825	31167166
0,80	0,1	8	4	50	0,9	0,76	8,61	8,81	9,22	10,71	A	TCR101-008-0010-0800X050-HP825	31167167
0,80	0,1	8	6	60	0,9	0,76	8,61	8,81	9,22	10,71	A	TCR101-008-0010-0800X060-HP825	31167168
0,80	0,1	10	6	60	0,9	0,76	10,66	10,99	11,50	13,37	A	TCR101-008-0010-1000X060-HP825	31167169
1,00	0,2	3	4	50	1,2	0,94	3,48	3,59	3,69	4,11	A	TCR101-010-0020-0300X050-HP825	31167170
1,00	0,2	4	4	50	1,2	0,94	4,52	4,65	4,76	5,43	A	TCR101-010-0020-0400X050-HP825	31167171
1,00	0,2	5	4	50	1,2	0,94	5,55	5,70	5,84	6,76	A	TCR101-010-0020-0500X050-HP825	31167172
1,00	0,2	6	4	50	1,2	0,94	6,58	6,75	6,98	8,09	A	TCR101-010-0020-0600X050-HP825	31167173
1,00	0,2	8	4	50	1,2	0,94	8,64	8,85	9,26	10,74	A	TCR101-010-0020-0800X050-HP825	31167174
1,00	0,2	10	4	50	1,2	0,94	10,69	11,03	11,54	13,40	A	TCR101-010-0020-1000X050-HP825	31167175

## OptiMill®-3D-CR | TCR101 | Eckradiusfräser, Ausführung mit Hals, z=2

Baumaße							Arbeitstiefe bei x° Formschräge				Typ	Spezifikation	Bestell-Nr.
d <sub>1</sub>	R	l <sub>3</sub>	d <sub>2</sub> h5	l <sub>1</sub>	l <sub>2</sub>	d <sub>3</sub>	0,5°	1°	1,5°	3°			
1,00	0,2	10	6	60	1,2	0,94	10,69	11,03	11,54	13,40	A	TCR101-010-0020-1000X060-HP825	31167176
1,00	0,2	12	6	60	1,2	0,94	12,73	13,21	13,82	16,05	A	TCR101-010-0020-1200X060-HP825	31167177
1,00	0,2	15	6	60	1,2	0,94	15,80	16,48	17,24	20,03	A	TCR101-010-0020-1500X060-HP825	31167178
1,50	0,2	5	4	50	1,7	1,44	5,55	5,70	5,84	6,76	A	TCR101-015-0020-0500X050-HP819	31167179
1,50	0,2	6	4	50	1,7	1,44	6,58	6,75	6,98	8,09	A	TCR101-015-0020-0600X050-HP819	31167180
1,50	0,2	8	4	50	1,7	1,44	8,64	8,85	9,26	10,74	A	TCR101-015-0020-0800X050-HP819	31167181
1,50	0,2	10	4	50	1,7	1,44	10,69	11,03	11,54	13,40	A	TCR101-015-0020-1000X050-HP819	31167182
1,50	0,2	10	6	60	1,7	1,44	10,69	11,03	11,54	13,40	A	TCR101-015-0020-1000X060-HP819	31167183
1,50	0,2	12	4	50	1,7	1,44	12,73	13,21	13,82	16,05	A	TCR101-015-0020-1200X050-HP819	31167184
1,50	0,2	12	6	60	1,7	1,44	12,73	13,21	13,82	16,05	A	TCR101-015-0020-1200X060-HP819	31167185
1,50	0,2	15	4	50	1,7	1,44	15,80	16,48	17,24	20,03	A	TCR101-015-0020-1500X050-HP819	31167186
1,50	0,2	15	6	60	1,7	1,44	15,80	16,48	17,24	20,03	A	TCR101-015-0020-1500X060-HP819	31167187
2,00	0,2	6	4	50	2,3	1,94	7,03	7,35	7,63	8,29	A	TCR101-020-0020-0600X050-HP803	31167193
2,00	0,2	8	4	50	2,3	1,94	9,13	9,51	9,82	10,74	A	TCR101-020-0020-0800X050-HP803	31167194
2,00	0,2	10	4	50	2,3	1,94	11,22	11,64	11,99	13,40	A	TCR101-020-0020-1000X050-HP803	31167195
2,00	0,2	12	4	50	2,3	1,94	13,31	13,77	14,14	16,05	A	TCR101-020-0020-1200X050-HP803	31167196
2,00	0,2	15	4	50	2,3	1,94	16,42	16,94	17,35	19,85	A	TCR101-020-0020-1500X050-HP803	31167197
2,00	0,2	15	6	60	2,3	1,94	16,42	16,94	17,35	20,03	A	TCR101-020-0020-1500X060-HP803	31167198
2,00	0,2	18	4	50	2,3	1,94	19,53	20,09	20,66	22,85	A	TCR101-020-0020-1800X050-HP803	31167199
2,00	0,2	20	4	50	2,3	1,94	21,60	22,19	22,94	24,85	A	TCR101-020-0020-2000X050-HP803	31167200
2,00	0,2	20	6	75	2,3	1,94	21,60	22,19	22,94	26,67	A	TCR101-020-0020-2000X075-HP803	31167201
2,00	0,2	25	6	75	2,3	1,94	26,75	27,41	28,65	33,30	A	TCR101-020-0020-2500X075-HP803	31167202
2,00	0,5	6	4	50	2,3	1,94	7,02	7,33	7,60	8,25	A	TCR101-020-0050-0600X050-HP803	31167203
2,00	0,5	8	4	50	2,3	1,94	9,12	9,49	9,79	10,65	A	TCR101-020-0050-0800X050-HP803	31167204
2,00	0,5	10	4	50	2,3	1,94	11,21	11,63	11,96	13,30	A	TCR101-020-0050-1000X050-HP803	31167205
2,00	0,5	12	4	50	2,3	1,94	13,30	13,75	14,12	15,95	A	TCR101-020-0050-1200X050-HP803	31167206
2,00	0,5	15	4	50	2,3	1,94	16,41	16,92	17,33	19,85	A	TCR101-020-0050-1500X050-HP803	31167207
2,00	0,5	15	6	60	2,3	1,94	16,41	16,92	17,33	19,94	A	TCR101-020-0050-1500X060-HP803	31167208
2,00	0,5	18	4	50	2,3	1,94	19,52	20,08	20,62	22,85	A	TCR101-020-0050-1800X050-HP803	31167209
2,00	0,5	20	4	50	2,3	1,94	21,59	22,18	22,90	24,85	A	TCR101-020-0050-2000X050-HP803	31167210
2,00	0,5	20	6	75	2,3	1,94	21,59	22,18	22,90	26,57	A	TCR101-020-0050-2000X075-HP803	31167211
2,00	0,5	25	6	75	2,3	1,94	26,74	27,40	28,60	33,21	A	TCR101-020-0050-2500X075-HP803	31167212
2,50	0,5	8	4	50	2,9	2,44	9,12	9,49	9,79	10,65	A	TCR101-025-0050-0800X050-HP803	31167213
2,50	0,5	10	4	50	2,9	2,44	11,21	11,63	11,96	13,30	A	TCR101-025-0050-1000X050-HP803	31167214
2,50	0,5	15	4	50	2,9	2,44	16,41	16,92	17,33	18,67	A	TCR101-025-0050-1500X050-HP803	31167215
2,50	0,5	15	6	60	2,9	2,44	16,41	16,92	17,33	19,94	A	TCR101-025-0050-1500X060-HP803	31167216
2,50	0,5	20	4	50	2,9	2,44	21,59	22,18	22,90	23,67	A	TCR101-025-0050-2000X050-HP803	31167217
2,50	0,5	20	6	75	2,9	2,44	21,59	22,18	22,90	26,57	A	TCR101-025-0050-2000X075-HP803	31190296
2,50	0,5	25	6	75	2,9	2,44	26,74	27,40	28,60	33,21	A	TCR101-025-0050-2500X075-HP803	31190297
3,00	0,2	10	6	60	3,5	2,94	11,22	11,64	11,99	13,40	A	TCR101-030-0020-1000X060-HP803	31167219
3,00	0,2	15	6	60	3,5	2,94	16,42	16,94	17,35	20,03	A	TCR101-030-0020-1500X060-HP803	31167220
3,00	0,2	20	6	60	3,5	2,94	21,60	22,19	22,94	26,67	A	TCR101-030-0020-2000X060-HP803	31167221
3,00	0,2	25	6	75	3,5	2,94	26,75	27,41	28,65	32,20	A	TCR101-030-0020-2500X075-HP803	31167222
3,00	0,5	10	6	60	3,5	2,94	11,21	11,63	11,96	13,30	A	TCR101-030-0050-1000X060-HP803	31167223
3,00	0,5	15	6	60	3,5	2,94	16,41	16,92	17,33	19,94	A	TCR101-030-0050-1500X060-HP803	31167224
3,00	0,5	20	6	60	3,5	2,94	21,59	22,18	22,90	26,57	A	TCR101-030-0050-2000X060-HP803	31167225
3,00	0,5	25	6	75	3,5	2,94	26,74	27,40	28,60	32,20	A	TCR101-030-0050-2500X075-HP803	31167226
4,00	0,2	10	6	60	4,6	3,94	11,22	11,64	11,99	13,40	A	TCR101-040-0020-1000X060-HP803	31167227
4,00	0,2	15	6	60	4,6	3,94	16,42	16,94	17,35	19,85	A	TCR101-040-0020-1500X060-HP803	31167228
4,00	0,2	20	6	60	4,6	3,94	21,60	22,19	22,94	24,85	A	TCR101-040-0020-2000X060-HP803	31167229
4,00	0,2	25	6	75	4,6	3,94	26,75	27,41	28,65	29,85	A	TCR101-040-0020-2500X075-HP803	31167230
4,00	0,2	30	6	75	4,6	3,94	31,89	32,82	34,35	34,85	A	TCR101-040-0020-3000X075-HP803	31167231
4,00	0,2	35	6	75	4,6	3,94	37,02	38,27	39,85	-	A	TCR101-040-0020-3500X075-HP803	31167232
4,00	0,5	10	6	60	4,6	3,94	11,21	11,63	11,96	13,30	A	TCR101-040-0050-1000X060-HP803	31167233
4,00	0,5	15	6	60	4,6	3,94	16,41	16,92	17,33	19,85	A	TCR101-040-0050-1500X060-HP803	31167234
4,00	0,5	20	6	60	4,6	3,94	21,59	22,18	22,90	24,85	A	TCR101-040-0050-2000X060-HP803	31167235
4,00	0,5	25	6	75	4,6	3,94	26,74	27,40	28,60	29,85	A	TCR101-040-0050-2500X075-HP803	31167236

Fortsetzung auf nächster Seite.

## OptiMill®-3D-CR | TCR101 | Eckradiusfräser, Ausführung mit Hals, z=2

Baumaße							Arbeitstiefe bei x° Formschräge				Typ	Spezifikation	Bestell-Nr.
d <sub>1</sub>	R	l <sub>3</sub>	d <sub>2</sub> h5	l <sub>1</sub>	l <sub>2</sub>	d <sub>3</sub>	0,5°	1°	1,5°	3°			
4,00	0,5	30	6	75	4,6	3,94	31,89	32,79	34,31	34,85	A	TCR101-040-0050-3000X075-HP803	31167237
4,00	0,5	35	6	75	4,6	3,94	37,02	38,24	39,85	-	A	TCR101-040-0050-3500X075-HP803	31167238
5,00	0,2	15	6	60	5,8	4,9	15,88	16,58	17,35	17,59	C	TCR101-050-0020-1500X060-HP803	31167239
5,00	0,2	20	6	60	5,8	4,9	21,09	22,03	22,59	-	C	TCR101-050-0020-2000X060-HP803	31167240
5,00	0,2	25	6	60	5,8	4,9	26,31	27,48	27,59	-	C	TCR101-050-0020-2500X060-HP803	31167241
5,00	0,2	30	6	75	5,8	4,9	31,52	32,59	-	-	C	TCR101-050-0020-3000X075-HP803	31167242
5,00	0,5	15	6	60	5,8	4,9	15,87	16,55	17,31	17,59	C	TCR101-050-0050-1500X060-HP803	31167243
5,00	0,5	20	6	60	5,8	4,9	21,08	22,00	22,59	-	C	TCR101-050-0050-2000X060-HP803	31167244
5,00	0,5	25	6	60	5,8	4,9	26,29	27,45	27,59	-	C	TCR101-050-0050-2500X060-HP803	31167245
5,00	0,5	30	6	75	5,8	4,9	31,51	32,59	-	-	C	TCR101-050-0050-3000X075-HP803	31167246
6,00	0,2	15	6	60	6,9	5,9	-	-	-	-	-	TCR101-060-0020-1500X060-HP803	31167247
6,00	0,2	20	6	60	6,9	5,9	-	-	-	-	-	TCR101-060-0020-2000X060-HP803	31167248
6,00	0,2	25	6	60	6,9	5,9	-	-	-	-	-	TCR101-060-0020-2500X060-HP803	31167249
6,00	0,2	30	6	75	6,9	5,9	-	-	-	-	-	TCR101-060-0020-3000X075-HP803	31167250
6,00	0,2	35	6	75	6,9	5,9	-	-	-	-	-	TCR101-060-0020-3500X075-HP803	31167251
6,00	0,3	15	6	60	6,9	5,9	-	-	-	-	-	TCR101-060-0030-1500X060-HP803	31167252
6,00	0,3	20	6	60	6,9	5,9	-	-	-	-	-	TCR101-060-0030-2000X060-HP803	31167253
6,00	0,3	25	6	60	6,9	5,9	-	-	-	-	-	TCR101-060-0030-2500X060-HP803	31167254
6,00	0,3	30	6	75	6,9	5,9	-	-	-	-	-	TCR101-060-0030-3000X075-HP803	31167255
6,00	0,3	35	6	75	6,9	5,9	-	-	-	-	-	TCR101-060-0030-3500X075-HP803	31167256
6,00	0,5	15	6	60	6,9	5,9	-	-	-	-	-	TCR101-060-0050-1500X060-HP803	31167257
6,00	0,5	20	6	60	6,9	5,9	-	-	-	-	-	TCR101-060-0050-2000X060-HP803	31167258
6,00	0,5	25	6	60	6,9	5,9	-	-	-	-	-	TCR101-060-0050-2500X060-HP803	31167259
6,00	0,5	30	6	75	6,9	5,9	-	-	-	-	-	TCR101-060-0050-3000X075-HP803	31167260
6,00	0,5	35	6	75	6,9	5,9	-	-	-	-	-	TCR101-060-0050-3500X075-HP803	31167261
6,00	1	15	6	60	6,9	5,9	-	-	-	-	-	TCR101-060-0100-1500X060-HP803	31167262
6,00	1	20	6	60	6,9	5,9	-	-	-	-	-	TCR101-060-0100-2000X060-HP803	31167263
6,00	1	25	6	60	6,9	5,9	-	-	-	-	-	TCR101-060-0100-2500X060-HP803	31167264
6,00	1	30	6	75	6,9	5,9	-	-	-	-	-	TCR101-060-0100-3000X075-HP803	31167265
6,00	1	35	6	75	6,9	5,9	-	-	-	-	-	TCR101-060-0100-3500X075-HP803	31167266
8,00	0,5	25	8	64	9,2	7,8	-	-	-	-	-	TCR101-080-0050-2500X064-HP803	31167267
8,00	0,5	50	8	100	9,2	7,8	-	-	-	-	-	TCR101-080-0050-5000X100-HP803	31167268
8,00	1	25	8	64	9,2	7,8	-	-	-	-	-	TCR101-080-0100-2500X064-HP803	31167269
8,00	1	50	8	100	9,2	7,8	-	-	-	-	-	TCR101-080-0100-5000X100-HP803	31167270
8,00	2	25	8	64	9,2	7,8	-	-	-	-	-	TCR101-080-0200-2500X064-HP803	31167271
8,00	2	50	8	100	9,2	7,8	-	-	-	-	-	TCR101-080-0200-5000X100-HP803	31167272
10,00	0,5	30	10	75	11,5	9,8	-	-	-	-	-	TCR101-100-0050-3000X075-HP803	31167273
10,00	0,5	50	10	100	11,5	9,8	-	-	-	-	-	TCR101-100-0050-5000X100-HP803	31167274
10,00	1	30	10	75	11,5	9,8	-	-	-	-	-	TCR101-100-0100-3000X075-HP803	31167275
10,00	1	50	10	100	11,5	9,8	-	-	-	-	-	TCR101-100-0100-5000X100-HP803	31167276
10,00	2	30	10	75	11,5	9,8	-	-	-	-	-	TCR101-100-0200-3000X075-HP803	31167277
10,00	2	50	10	100	11,5	9,8	-	-	-	-	-	TCR101-100-0200-5000X100-HP803	31167278
12,00	0,5	35	12	75	13,8	11,8	-	-	-	-	-	TCR101-120-0050-3500X075-HP803	31167279
12,00	0,5	60	12	100	13,8	11,8	-	-	-	-	-	TCR101-120-0050-6000X100-HP803	31167280
12,00	1	35	12	75	13,8	11,8	-	-	-	-	-	TCR101-120-0100-3500X075-HP803	31167281
12,00	1	60	12	100	13,8	11,8	-	-	-	-	-	TCR101-120-0100-6000X100-HP803	31167282
12,00	2	35	12	75	13,8	11,8	-	-	-	-	-	TCR101-120-0200-3500X075-HP803	31167283
12,00	2	60	12	100	13,8	11,8	-	-	-	-	-	TCR101-120-0200-6000X100-HP803	31167284



## Auf Anfrage erhältlich

Baumaße							Arbeitstiefe bei x° Formschräge				Typ	Spezifikation	Bestell-Nr.
d <sub>1</sub>	R	l <sub>3</sub>	d <sub>2</sub> h5	l <sub>1</sub>	l <sub>2</sub>	d <sub>3</sub>	0,5°	1°	1,5°	3°			
0,10	0,02	0,3	4	50	0,1	0,075	0,56	0,60	0,64	0,75	A	TCR101-001-0002-0030X050-HP825	31167121
0,10	0,02	0,3	6	60	0,1	0,075	0,56	0,60	0,64	0,75	A	TCR101-001-0002-0030X060-HP825	31167122
0,10	0,02	0,4	4	50	0,1	0,075	0,67	0,71	0,75	0,88	A	TCR101-001-0002-0040X050-HP825	31167123
0,10	0,02	0,4	6	60	0,1	0,075	0,67	0,71	0,75	0,88	A	TCR101-001-0002-0040X060-HP825	31167124
0,20	0,05	0,5	4	50	0,2	0,17	0,79	0,84	0,88	1,01	A	TCR101-002-0005-0050X050-HP825	31167125
0,20	0,05	0,5	6	60	0,2	0,17	0,79	0,84	0,88	1,01	A	TCR101-002-0005-0050X060-HP825	31167126
0,20	0,05	0,75	4	50	0,2	0,17	1,06	1,12	1,17	1,31	A	TCR101-002-0005-0075X050-HP825	31167127
0,20	0,05	1	4	50	0,2	0,17	1,32	1,39	1,45	1,62	A	TCR101-002-0005-0100X050-HP825	31167128
0,20	0,05	1	6	60	0,2	0,17	1,32	1,39	1,45	1,62	A	TCR101-002-0005-0100X060-HP825	31167129
0,20	0,05	1,25	4	50	0,2	0,17	1,59	1,66	1,73	1,91	A	TCR101-002-0005-0125X050-HP825	31167130
0,20	0,05	1,5	4	50	0,2	0,17	1,85	1,94	2,01	2,20	A	TCR101-002-0005-0150X050-HP825	31167131
0,20	0,05	1,5	6	60	0,2	0,17	1,85	1,94	2,01	2,20	A	TCR101-002-0005-0150X060-HP825	31167132
0,30	0,05	0,5	4	50	0,3	0,27	0,79	0,84	0,88	1,01	A	TCR101-003-0005-0050X050-HP825	31167133
0,30	0,05	0,75	4	50	0,3	0,27	1,06	1,12	1,17	1,31	A	TCR101-003-0005-0075X050-HP825	31167134
0,30	0,05	1	4	50	0,3	0,27	1,32	1,39	1,45	1,62	A	TCR101-003-0005-0100X050-HP825	31167135
0,30	0,05	1	6	60	0,3	0,27	1,32	1,39	1,45	1,62	A	TCR101-003-0005-0100X060-HP825	31167136
0,30	0,05	1,25	4	50	0,3	0,27	1,59	1,66	1,73	1,91	A	TCR101-003-0005-0125X050-HP825	31167137
0,30	0,05	1,5	4	50	0,3	0,27	1,85	1,94	2,01	2,20	A	TCR101-003-0005-0150X050-HP825	31167138
0,30	0,05	1,5	6	60	0,3	0,27	1,85	1,94	2,01	2,20	A	TCR101-003-0005-0150X060-HP825	31167139
0,30	0,05	2	6	60	0,3	0,27	2,37	2,48	2,56	2,78	A	TCR101-003-0005-0200X060-HP825	31167140
1,80	0,2	6	4	50	2,1	1,74	6,58	6,75	6,98	8,09	A	TCR101-018-0020-0600X050-HP819	31167188
1,80	0,2	8	4	50	2,1	1,74	8,64	8,85	9,26	10,74	A	TCR101-018-0020-0800X050-HP819	31167189
1,80	0,2	10	4	50	2,1	1,74	10,69	11,03	11,54	13,40	A	TCR101-018-0020-1000X050-HP819	31167190
1,80	0,2	15	4	50	2,1	1,74	15,80	16,48	17,24	20,03	A	TCR101-018-0020-1500X050-HP819	31167191
1,80	0,2	20	4	50	2,1	1,74	20,99	21,93	22,94	25,32	A	TCR101-018-0020-2000X050-HP819	31167192

Maßangaben in mm.

Schnittwertempfehlung siehe Kapitelende.

Sonderausführungen und andere Beschichtungen auf Anfrage.

# OptiMill®-3D-CR

Eckradiusfräser, Ausführung mit Hals, z=4  
TCR104

**Ausführung:**

Fräserdurchmesser: 3,00 - 12,00 mm  
 Schneidstoff: HP803  
 Schneidzahl: 4  
 Spiralwinkel: 30°  
 Toleranz Radiuskontur: ±0,005 wenn d<sub>1</sub> ≤ 6 mm  
 ±0,01 wenn d<sub>1</sub> > 6 mm

**Anwendung:**

Geeignet zur Bearbeitung von Werkstoffen bis 55 HRC.

**Schaftübergang:**

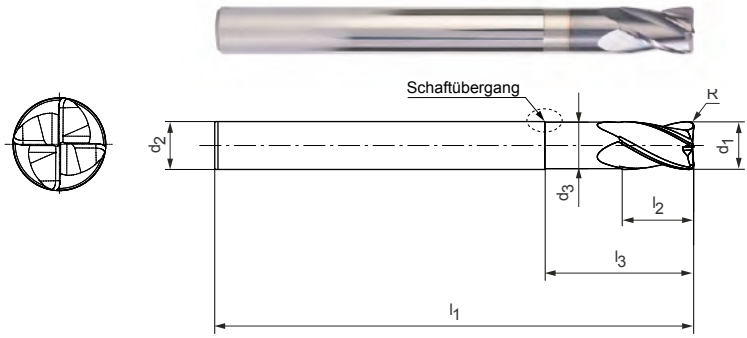
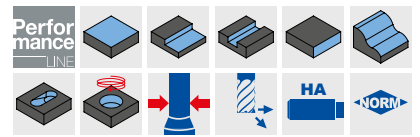
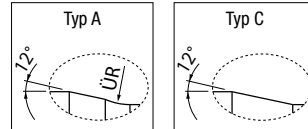

**Lagerhaltige Vorzugsbaureihe**

Baumaße					Arbeitstiefe bei x° Formschräge					Typ	Spezifikation	Bestell-Nr.	
d <sub>1</sub>	R	l <sub>3</sub>	d <sub>2</sub> h5	l <sub>1</sub>	l <sub>2</sub>	d <sub>3</sub>	0,5°	1°	1,5°				3°
3,00	0,2	10	6	60	3,5	2,94	11,22	11,64	11,99	13,40	A	TCR104-030-0020-1000X060-HP803	31167563
3,00	0,2	15	6	60	3,5	2,94	16,42	16,94	17,35	20,03	A	TCR104-030-0020-1500X060-HP803	31167564
3,00	0,2	20	6	60	3,5	2,94	21,60	22,19	22,94	26,67	A	TCR104-030-0020-2000X060-HP803	31167565
3,00	0,2	25	6	75	3,5	2,94	26,75	27,41	28,65	32,20	A	TCR104-030-0020-2500X075-HP803	31167566
3,00	0,5	10	6	60	3,5	2,94	11,21	11,63	11,96	13,30	A	TCR104-030-0050-1000X060-HP803	31167567
3,00	0,5	15	6	60	3,5	2,94	16,41	16,92	17,33	19,94	A	TCR104-030-0050-1500X060-HP803	31167568
3,00	0,5	20	6	60	3,5	2,94	21,59	22,18	22,90	26,57	A	TCR104-030-0050-2000X060-HP803	31167569
3,00	0,5	25	6	75	3,5	2,94	26,74	27,40	28,60	32,20	A	TCR104-030-0050-2500X075-HP803	31167570
4,00	0,2	10	6	60	4,6	3,94	11,22	11,64	11,99	13,40	A	TCR104-040-0020-1000X060-HP803	31167571
4,00	0,2	15	6	60	4,6	3,94	16,42	16,94	17,35	19,85	A	TCR104-040-0020-1500X060-HP803	31167572
4,00	0,2	20	6	60	4,6	3,94	21,60	22,19	22,94	24,85	A	TCR104-040-0020-2000X060-HP803	31167573
4,00	0,2	25	6	75	4,6	3,94	26,75	27,41	28,65	29,85	A	TCR104-040-0020-2500X075-HP803	31167574
4,00	0,2	30	6	75	4,6	3,94	31,89	32,82	34,35	34,85	A	TCR104-040-0020-3000X075-HP803	31167575
4,00	0,5	10	6	60	4,6	3,94	11,21	11,63	11,96	13,30	A	TCR104-040-0050-1000X060-HP803	31167576
4,00	0,5	15	6	60	4,6	3,94	16,41	16,92	17,33	19,85	A	TCR104-040-0050-1500X060-HP803	31167577
4,00	0,5	20	6	60	4,6	3,94	21,59	22,18	22,90	24,85	A	TCR104-040-0050-2000X060-HP803	31167578
4,00	0,5	25	6	75	4,6	3,94	26,74	27,40	28,60	29,85	A	TCR104-040-0050-2500X075-HP803	31167579
4,00	0,5	30	6	75	4,6	3,94	31,89	32,79	34,31	34,85	A	TCR104-040-0050-3000X075-HP803	31167580
5,00	0,2	15	6	60	5,8	4,9	15,88	16,58	17,35	17,59	C	TCR104-050-0020-1500X060-HP803	31167581
5,00	0,2	20	6	60	5,8	4,9	21,09	22,03	22,59	-	C	TCR104-050-0020-2000X060-HP803	31167582
5,00	0,2	25	6	60	5,8	4,9	26,31	27,48	27,59	-	C	TCR104-050-0020-2500X060-HP803	31167583
5,00	0,2	30	6	75	5,8	4,9	31,52	32,59	-	-	C	TCR104-050-0020-3000X075-HP803	31167584
5,00	0,5	15	6	60	5,8	4,9	15,87	16,55	17,31	17,59	C	TCR104-050-0050-1500X060-HP803	31167585
5,00	0,5	20	6	60	5,8	4,9	21,08	22,00	22,59	-	C	TCR104-050-0050-2000X060-HP803	31167586
5,00	0,5	25	6	60	5,8	4,9	26,29	27,45	27,59	-	C	TCR104-050-0050-2500X060-HP803	31167587
5,00	0,5	30	6	75	5,8	4,9	31,51	32,59	-	-	C	TCR104-050-0050-3000X075-HP803	31167588
6,00	0,2	15	6	60	6,9	5,9	-	-	-	-	-	TCR104-060-0020-1500X060-HP803	31167589
6,00	0,2	20	6	60	6,9	5,9	-	-	-	-	-	TCR104-060-0020-2000X060-HP803	31167590
6,00	0,2	25	6	60	6,9	5,9	-	-	-	-	-	TCR104-060-0020-2500X060-HP803	31167591
6,00	0,2	30	6	75	6,9	5,9	-	-	-	-	-	TCR104-060-0020-3000X075-HP803	31167592
6,00	0,2	35	6	75	6,9	5,9	-	-	-	-	-	TCR104-060-0020-3500X075-HP803	31167593
6,00	0,3	15	6	60	6,9	5,9	-	-	-	-	-	TCR104-060-0030-1500X060-HP803	31167594
6,00	0,3	20	6	60	6,9	5,9	-	-	-	-	-	TCR104-060-0030-2000X060-HP803	31167595
6,00	0,3	25	6	60	6,9	5,9	-	-	-	-	-	TCR104-060-0030-2500X060-HP803	31167596
6,00	0,3	30	6	75	6,9	5,9	-	-	-	-	-	TCR104-060-0030-3000X075-HP803	31167597

**OptiMill®-3D-CR | TCR104 | Eckradiusfräser, Ausführung mit Hals, z=4**

Baumaße							Arbeitstiefe bei x° Formschräge				Typ	Spezifikation	Bestell-Nr.
d <sub>1</sub>	R	l <sub>3</sub>	d <sub>2</sub> h5	l <sub>1</sub>	l <sub>2</sub>	d <sub>3</sub>	0,5°	1°	1,5°	3°			
6,00	0,3	35	6	75	6,9	5,9	-	-	-	-	-	TCR104-060-0030-3500X075-HP803	31167598
6,00	0,5	15	6	60	6,9	5,9	-	-	-	-	-	TCR104-060-0050-1500X060-HP803	31167599
6,00	0,5	20	6	60	6,9	5,9	-	-	-	-	-	TCR104-060-0050-2000X060-HP803	31167600
6,00	0,5	25	6	60	6,9	5,9	-	-	-	-	-	TCR104-060-0050-2500X060-HP803	31167601
6,00	0,5	30	6	75	6,9	5,9	-	-	-	-	-	TCR104-060-0050-3000X075-HP803	31167602
6,00	0,5	35	6	75	6,9	5,9	-	-	-	-	-	TCR104-060-0050-3500X075-HP803	31167603
6,00	1	15	6	60	6,9	5,9	-	-	-	-	-	TCR104-060-0100-1500X060-HP803	31167604
6,00	1	20	6	60	6,9	5,9	-	-	-	-	-	TCR104-060-0100-2000X060-HP803	31167605
6,00	1	25	6	60	6,9	5,9	-	-	-	-	-	TCR104-060-0100-2500X060-HP803	31167606
6,00	1	30	6	75	6,9	5,9	-	-	-	-	-	TCR104-060-0100-3000X075-HP803	31167607
6,00	1	35	6	75	6,9	5,9	-	-	-	-	-	TCR104-060-0100-3500X075-HP803	31167608
8,00	0,5	25	8	64	9,2	7,8	-	-	-	-	-	TCR104-080-0050-2500X064-HP803	31167609
8,00	0,5	50	8	100	9,2	7,8	-	-	-	-	-	TCR104-080-0050-5000X100-HP803	31167610
8,00	1	25	8	64	9,2	7,8	-	-	-	-	-	TCR104-080-0100-2500X064-HP803	31167611
8,00	1	50	8	100	9,2	7,8	-	-	-	-	-	TCR104-080-0100-5000X100-HP803	31167612
8,00	2	25	8	64	9,2	7,8	-	-	-	-	-	TCR104-080-0200-2500X064-HP803	31167613
8,00	2	50	8	100	9,2	7,8	-	-	-	-	-	TCR104-080-0200-5000X100-HP803	31167614
10,00	0,5	30	10	75	11,5	9,8	-	-	-	-	-	TCR104-100-0050-3000X075-HP803	31167615
10,00	0,5	50	10	100	11,5	9,8	-	-	-	-	-	TCR104-100-0050-5000X100-HP803	31167616
10,00	1	30	10	75	11,5	9,8	-	-	-	-	-	TCR104-100-0100-3000X075-HP803	31167617
10,00	1	50	10	100	11,5	9,8	-	-	-	-	-	TCR104-100-0100-5000X100-HP803	31167618
10,00	2	30	10	75	11,5	9,8	-	-	-	-	-	TCR104-100-0200-3000X075-HP803	31167619
10,00	2	50	10	100	11,5	9,8	-	-	-	-	-	TCR104-100-0200-5000X100-HP803	31167620
12,00	0,5	35	12	75	13,8	11,8	-	-	-	-	-	TCR104-120-0050-3500X075-HP803	31167621
12,00	0,5	60	12	100	13,8	11,8	-	-	-	-	-	TCR104-120-0050-6000X100-HP803	31167622
12,00	1	35	12	75	13,8	11,8	-	-	-	-	-	TCR104-120-0100-3500X075-HP803	31167623
12,00	1	60	12	100	13,8	11,8	-	-	-	-	-	TCR104-120-0100-6000X100-HP803	31167624
12,00	2	35	12	75	13,8	11,8	-	-	-	-	-	TCR104-120-0200-3500X075-HP803	31167625
12,00	2	60	12	100	13,8	11,8	-	-	-	-	-	TCR104-120-0200-6000X100-HP803	31167626

Maßangaben in mm.

Schnittwertempfehlung siehe Kapitelende.

Sonderausführungen und andere Beschichtungen auf Anfrage.

# OptiMill®-3D-CR-Hardened

Eckradiusfräser, Ausführung mit Hals, z=2  
TCR107

**Ausführung:**

Fräserdurchmesser: 0,10 - 12,00 mm  
 Schneidstoff: HP808/HP818  
 Schneidzahl: 2  
 Spiralwinkel: 28°  
 Toleranz Radiuskontur: ±0,005 wenn d<sub>1</sub> ≤ 6 mm  
 ±0,01 wenn d<sub>1</sub> > 6 mm

**Anwendung:**

Geeignet zur Bearbeitung von Werkstoffen bis 68 HRC.

**Schaftübergang:**

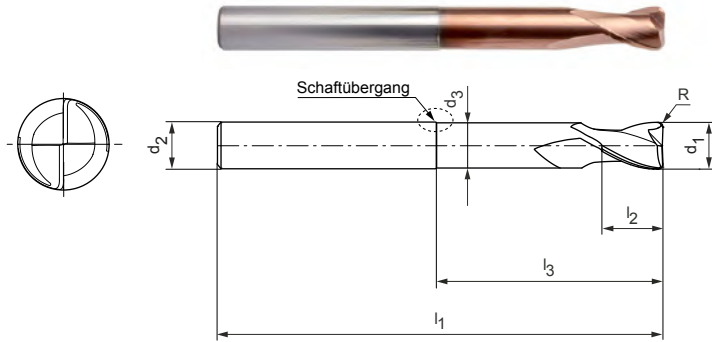
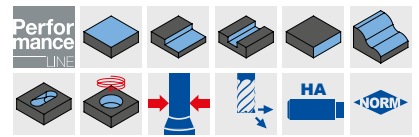
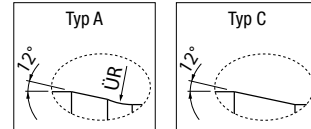

**Lagerhaltige Vorzugsbaureihe**

Baumaße					Arbeitstiefe bei x° Formschräge				Typ	Spezifikation	Bestell-Nr.		
d <sub>1</sub>	R	l <sub>3</sub>	d <sub>2</sub> h <sub>5</sub>	l <sub>1</sub>	l <sub>2</sub>	d <sub>3</sub>	0,5°	1°				1,5°	3°
0,10	0,02	0,3	4	50	0,1	0,075	0,56	0,60	0,64	0,75	A	TCR107-001-0002-0030X050-HP818	31156614
0,20	0,05	0,5	6	60	0,2	0,17	0,79	0,84	0,88	1,01	A	TCR107-002-0005-0050X060-HP818	31156619
0,30	0,05	0,5	4	50	0,3	0,27	0,79	0,84	0,88	1,01	A	TCR107-003-0005-0050X050-HP818	31156626
0,40	0,1	0,75	4	50	0,5	0,37	1,05	1,11	1,16	1,30	A	TCR107-004-0010-0075X050-HP818	31156634
0,40	0,1	1	4	50	0,5	0,37	1,32	1,39	1,45	1,61	A	TCR107-004-0010-0100X050-HP818	31156635
0,40	0,1	1,5	4	50	0,5	0,37	1,85	1,93	2,01	2,20	A	TCR107-004-0010-0150X050-HP818	31156636
0,40	0,1	2	4	50	0,5	0,37	2,37	2,47	2,56	2,77	A	TCR107-004-0010-0200X050-HP818	31156637
0,40	0,1	2	6	60	0,5	0,37	2,37	2,47	2,56	2,77	A	TCR107-004-0010-0200X060-HP818	31156638
0,40	0,1	3	6	60	0,5	0,37	3,42	3,54	3,65	4,04	A	TCR107-004-0010-0300X060-HP818	31156639
0,50	0,1	1,5	4	50	0,6	0,46	1,88	1,95	2,03	2,21	A	TCR107-005-0010-0150X050-HP818	31156640
0,50	0,1	2	4	50	0,6	0,46	2,40	2,49	2,58	2,79	A	TCR107-005-0010-0200X050-HP818	31156641
0,50	0,1	3	4	50	0,6	0,46	3,44	3,56	3,66	4,07	A	TCR107-005-0010-0300X050-HP818	31156642
0,50	0,1	4	4	50	0,6	0,46	4,48	4,62	4,74	5,40	A	TCR107-005-0010-0400X050-HP818	31156643
0,50	0,1	4	6	60	0,6	0,46	4,48	4,62	4,74	5,40	A	TCR107-005-0010-0400X060-HP818	31156644
0,50	0,1	5	4	50	0,6	0,46	5,51	5,67	5,81	6,73	A	TCR107-005-0010-0500X050-HP818	31156645
0,50	0,1	6	4	50	0,6	0,46	6,55	6,72	6,94	8,06	A	TCR107-005-0010-0600X050-HP818	31156646
0,50	0,1	6	6	60	0,6	0,46	6,55	6,72	6,94	8,06	A	TCR107-005-0010-0600X060-HP818	31156647
0,60	0,1	2	4	50	0,7	0,56	2,40	2,49	2,58	2,79	A	TCR107-006-0010-0200X050-HP818	31156648
0,60	0,1	3	4	50	0,7	0,56	3,44	3,56	3,66	4,07	A	TCR107-006-0010-0300X050-HP818	31156649
0,60	0,1	4	4	50	0,7	0,56	4,48	4,62	4,74	5,40	A	TCR107-006-0010-0400X050-HP818	31156650
0,60	0,1	4	6	60	0,7	0,56	4,48	4,62	4,74	5,40	A	TCR107-006-0010-0400X060-HP818	31156651
0,60	0,1	5	4	50	0,7	0,56	5,51	5,67	5,81	6,73	A	TCR107-006-0010-0500X050-HP818	31156652
0,60	0,1	6	4	50	0,7	0,56	6,55	6,72	6,94	8,06	A	TCR107-006-0010-0600X050-HP818	31156653
0,60	0,1	6	6	60	0,7	0,56	6,55	6,72	6,94	8,06	A	TCR107-006-0010-0600X060-HP818	31156654
0,60	0,1	8	6	60	0,7	0,56	8,61	8,81	9,22	10,71	A	TCR107-006-0010-0800X060-HP818	31156655
0,80	0,1	3	4	50	0,9	0,76	3,44	3,56	3,66	4,07	A	TCR107-008-0010-0300X050-HP818	31156656
0,80	0,1	4	4	50	0,9	0,76	4,48	4,62	4,74	5,40	A	TCR107-008-0010-0400X050-HP818	31156657
0,80	0,1	6	4	50	0,9	0,76	6,55	6,72	6,94	8,06	A	TCR107-008-0010-0600X050-HP818	31156658
0,80	0,1	6	6	60	0,9	0,76	6,55	6,72	6,94	8,06	A	TCR107-008-0010-0600X060-HP818	31156659
0,80	0,1	8	4	50	0,9	0,76	8,61	8,81	9,22	10,71	A	TCR107-008-0010-0800X050-HP818	31156660
0,80	0,1	8	6	60	0,9	0,76	8,61	8,81	9,22	10,71	A	TCR107-008-0010-0800X060-HP818	31156661
0,80	0,1	10	6	60	0,9	0,76	10,66	10,99	11,50	13,37	A	TCR107-008-0010-1000X060-HP818	31156662
1,00	0,2	3	4	50	1,2	0,94	3,48	3,59	3,69	4,11	A	TCR107-010-0020-0300X050-HP818	31156663
1,00	0,2	4	4	50	1,2	0,94	4,52	4,65	4,76	5,43	A	TCR107-010-0020-0400X050-HP818	31156664
1,00	0,2	5	4	50	1,2	0,94	5,55	5,70	5,84	6,76	A	TCR107-010-0020-0500X050-HP818	31156665

**OptiMill®-3D-CR-Hardened | TCR107 | Eckradiusfräser, Ausführung mit Hals, z=2**

Baumaße							Arbeitstiefe bei x° Formschräge				Typ	Spezifikation	Bestell-Nr.
d <sub>1</sub>	R	l <sub>3</sub>	d <sub>2</sub> h5	l <sub>1</sub>	l <sub>2</sub>	d <sub>3</sub>	0,5°	1°	1,5°	3°			
1,00	0,2	6	4	50	1,2	0,94	6,58	6,75	6,98	8,09	A	TCR107-010-0020-0600X050-HP818	31156666
1,00	0,2	8	4	50	1,2	0,94	8,64	8,85	9,26	10,74	A	TCR107-010-0020-0800X050-HP818	31156667
1,00	0,2	10	4	50	1,2	0,94	10,69	11,03	11,54	13,40	A	TCR107-010-0020-1000X050-HP818	31156668
1,00	0,2	10	6	60	1,2	0,94	10,69	11,03	11,54	13,40	A	TCR107-010-0020-1000X060-HP818	31156669
1,00	0,2	12	6	60	1,2	0,94	12,73	13,21	13,82	16,05	A	TCR107-010-0020-1200X060-HP818	31156670
1,00	0,2	15	6	60	1,2	0,94	15,80	16,48	17,24	20,03	A	TCR107-010-0020-1500X060-HP818	31156671
1,50	0,2	5	4	50	1,7	1,44	5,55	5,70	5,84	6,76	A	TCR107-015-0020-0500X050-HP818	31156672
1,50	0,2	6	4	50	1,7	1,44	6,58	6,75	6,98	8,09	A	TCR107-015-0020-0600X050-HP818	31156673
1,50	0,2	8	4	50	1,7	1,44	8,64	8,85	9,26	10,74	A	TCR107-015-0020-0800X050-HP818	31156674
1,50	0,2	10	4	50	1,7	1,44	10,69	11,03	11,54	13,40	A	TCR107-015-0020-1000X050-HP818	31156675
1,50	0,2	10	6	60	1,7	1,44	10,69	11,03	11,54	13,40	A	TCR107-015-0020-1000X060-HP818	31156676
1,50	0,2	12	4	50	1,7	1,44	12,73	13,21	13,82	16,05	A	TCR107-015-0020-1200X050-HP818	31156677
1,50	0,2	12	6	60	1,7	1,44	12,73	13,21	13,82	16,05	A	TCR107-015-0020-1200X060-HP818	31156678
1,50	0,2	15	4	50	1,7	1,44	15,80	16,48	17,24	20,03	A	TCR107-015-0020-1500X050-HP818	31156679
1,50	0,2	15	6	60	1,7	1,44	15,80	16,48	17,24	20,03	A	TCR107-015-0020-1500X060-HP818	31156680
2,00	0,2	6	4	50	2,3	1,94	7,03	7,35	7,63	8,29	A	TCR107-020-0020-0600X050-HP808	31156686
2,00	0,2	8	4	50	2,3	1,94	9,13	9,51	9,82	10,74	A	TCR107-020-0020-0800X050-HP808	31156687
2,00	0,2	10	4	50	2,3	1,94	11,22	11,64	11,99	13,40	A	TCR107-020-0020-1000X050-HP808	31156688
2,00	0,2	12	4	50	2,3	1,94	13,31	13,77	14,14	16,05	A	TCR107-020-0020-1200X050-HP808	31156689
2,00	0,2	15	4	50	2,3	1,94	16,42	16,94	17,35	19,85	A	TCR107-020-0020-1500X050-HP808	31156690
2,00	0,2	15	6	60	2,3	1,94	16,42	16,94	17,35	20,03	A	TCR107-020-0020-1500X060-HP808	31156691
2,00	0,2	18	4	50	2,3	1,94	19,53	20,09	20,66	22,85	A	TCR107-020-0020-1800X050-HP808	31156692
2,00	0,2	20	4	50	2,3	1,94	21,60	22,19	22,94	24,85	A	TCR107-020-0020-2000X050-HP808	31156693
2,00	0,2	20	6	75	2,3	1,94	21,60	22,19	22,94	26,67	A	TCR107-020-0020-2000X075-HP808	31156694
2,00	0,2	25	6	75	2,3	1,94	26,75	27,41	28,65	33,30	A	TCR107-020-0020-2500X075-HP808	31156695
2,00	0,5	6	4	50	2,3	1,94	7,02	7,33	7,60	8,25	A	TCR107-020-0050-0600X050-HP808	31156696
2,00	0,5	8	4	50	2,3	1,94	9,12	9,49	9,79	10,65	A	TCR107-020-0050-0800X050-HP808	31156697
2,00	0,5	10	4	50	2,3	1,94	11,21	11,63	11,96	13,30	A	TCR107-020-0050-1000X050-HP808	31156698
2,00	0,5	12	4	50	2,3	1,94	13,30	13,75	14,12	15,95	A	TCR107-020-0050-1200X050-HP808	31156699
2,00	0,5	15	4	50	2,3	1,94	16,41	16,92	17,33	19,85	A	TCR107-020-0050-1500X050-HP808	31156700
2,00	0,5	15	6	60	2,3	1,94	16,41	16,92	17,33	19,94	A	TCR107-020-0050-1500X060-HP808	31156701
2,00	0,5	18	4	50	2,3	1,94	19,52	20,08	20,62	22,85	A	TCR107-020-0050-1800X050-HP808	31156702
2,00	0,5	20	4	50	2,3	1,94	21,59	22,18	22,90	24,85	A	TCR107-020-0050-2000X050-HP808	31156703
2,00	0,5	20	6	75	2,3	1,94	21,59	22,18	22,90	26,57	A	TCR107-020-0050-2000X075-HP808	31156704
2,00	0,5	25	6	75	2,3	1,94	26,74	27,40	28,60	33,21	A	TCR107-020-0050-2500X075-HP808	31156705
2,50	0,5	8	4	50	2,9	2,44	9,12	9,49	9,79	10,65	A	TCR107-025-0050-0800X050-HP808	31156706
2,50	0,5	10	4	50	2,9	2,44	11,21	11,63	11,96	13,30	A	TCR107-025-0050-1000X050-HP808	31156707
2,50	0,5	15	4	50	2,9	2,44	16,41	16,92	17,33	18,67	A	TCR107-025-0050-1500X050-HP808	31156708
2,50	0,5	15	6	60	2,9	2,44	16,41	16,92	17,33	19,94	A	TCR107-025-0050-1500X060-HP808	31156709
2,50	0,5	20	4	50	2,9	2,44	21,59	22,18	22,90	23,67	A	TCR107-025-0050-2000X050-HP808	31156710
2,50	0,5	20	6	75	2,9	2,44	21,59	22,18	22,90	26,57	A	TCR107-025-0050-2000X075-HP808	31156712
3,00	0,2	10	6	60	3,5	2,94	11,22	11,64	11,99	13,40	A	TCR107-030-0020-1000X060-HP808	31156714
3,00	0,2	15	6	60	3,5	2,94	16,42	16,94	17,35	20,03	A	TCR107-030-0020-1500X060-HP808	31156715
3,00	0,2	20	6	60	3,5	2,94	21,60	22,19	22,94	26,67	A	TCR107-030-0020-2000X060-HP808	31156716
3,00	0,2	25	6	75	3,5	2,94	26,75	27,41	28,65	32,20	A	TCR107-030-0020-2500X075-HP808	31156717
3,00	0,5	10	6	60	3,5	2,94	11,21	11,63	11,96	13,30	A	TCR107-030-0050-1000X060-HP808	31156718
3,00	0,5	15	6	60	3,5	2,94	16,41	16,92	17,33	19,94	A	TCR107-030-0050-1500X060-HP808	31156719
3,00	0,5	20	6	60	3,5	2,94	21,59	22,18	22,90	26,57	A	TCR107-030-0050-2000X060-HP808	31156720
3,00	0,5	25	6	75	3,5	2,94	26,74	27,40	28,60	32,20	A	TCR107-030-0050-2500X075-HP808	31156721
4,00	0,2	10	6	60	4,6	3,94	11,22	11,64	11,99	13,40	A	TCR107-040-0020-1000X060-HP808	31156722
4,00	0,2	15	6	60	4,6	3,94	16,42	16,94	17,35	19,85	A	TCR107-040-0020-1500X060-HP808	31156723
4,00	0,2	20	6	60	4,6	3,94	21,60	22,19	22,94	24,85	A	TCR107-040-0020-2000X060-HP808	31156724
4,00	0,2	25	6	75	4,6	3,94	26,75	27,41	28,65	29,85	A	TCR107-040-0020-2500X075-HP808	31156725
4,00	0,2	30	6	75	4,6	3,94	31,89	32,82	34,35	34,85	A	TCR107-040-0020-3000X075-HP808	31156726
4,00	0,2	35	6	75	4,6	3,94	37,02	38,27	39,85	-	A	TCR107-040-0020-3500X075-HP808	31156727
4,00	0,5	10	6	60	4,6	3,94	11,21	11,63	11,96	13,30	A	TCR107-040-0050-1000X060-HP808	31156728
4,00	0,5	15	6	60	4,6	3,94	16,41	16,92	17,33	19,85	A	TCR107-040-0050-1500X060-HP808	31156729

## OptiMill®-3D-CR-Hardened | TCR107 | Eckradiusfräser, Ausführung mit Hals, z=2

Baumaße						Arbeitstiefe bei x° Formschräge					Typ	Spezifikation	Bestell-Nr.
d <sub>1</sub>	R	l <sub>3</sub>	d <sub>2</sub> h5	l <sub>1</sub>	l <sub>2</sub>	d <sub>3</sub>	0,5°	1°	1,5°	3°			
4,00	0,5	20	6	60	4,6	3,94	21,59	22,18	22,90	24,85	A	TCR107-040-0050-2000X060-HP808	31156730
4,00	0,5	25	6	75	4,6	3,94	26,74	27,40	28,60	29,85	A	TCR107-040-0050-2500X075-HP808	31156731
4,00	0,5	30	6	75	4,6	3,94	31,89	32,79	34,31	34,85	A	TCR107-040-0050-3000X075-HP808	31156732
4,00	0,5	35	6	75	4,6	3,94	37,02	38,24	39,85	-	A	TCR107-040-0050-3500X075-HP808	31156733
5,00	0,2	15	6	60	5,8	4,9	15,88	16,58	17,35	17,59	C	TCR107-050-0020-1500X060-HP808	31156734
5,00	0,2	20	6	60	5,8	4,9	21,09	22,03	22,59	-	C	TCR107-050-0020-2000X060-HP808	31156735
5,00	0,2	25	6	60	5,8	4,9	26,31	27,48	27,59	-	C	TCR107-050-0020-2500X060-HP808	31156736
5,00	0,2	30	6	75	5,8	4,9	31,52	32,59	-	-	C	TCR107-050-0020-3000X075-HP808	31156737
5,00	0,5	15	6	60	5,8	4,9	15,87	16,55	17,31	17,59	C	TCR107-050-0050-1500X060-HP808	31156738
5,00	0,5	20	6	60	5,8	4,9	21,08	22,00	22,59	-	C	TCR107-050-0050-2000X060-HP808	31156739
5,00	0,5	25	6	60	5,8	4,9	26,29	27,45	27,59	-	C	TCR107-050-0050-2500X060-HP808	31156740
5,00	0,5	30	6	75	5,8	4,9	31,51	32,59	-	-	C	TCR107-050-0050-3000X075-HP808	31156741
6,00	0,2	15	6	60	6,9	5,9	-	-	-	-	-	TCR107-060-0020-1500X060-HP808	31156742
6,00	0,2	20	6	60	6,9	5,9	-	-	-	-	-	TCR107-060-0020-2000X060-HP808	31156743
6,00	0,2	25	6	60	6,9	5,9	-	-	-	-	-	TCR107-060-0020-2500X060-HP808	31156744
6,00	0,2	30	6	75	6,9	5,9	-	-	-	-	-	TCR107-060-0020-3000X075-HP808	31156745
6,00	0,2	35	6	75	6,9	5,9	-	-	-	-	-	TCR107-060-0020-3500X075-HP808	31156746
6,00	0,3	15	6	60	6,9	5,9	-	-	-	-	-	TCR107-060-0030-1500X060-HP808	31156747
6,00	0,3	20	6	60	6,9	5,9	-	-	-	-	-	TCR107-060-0030-2000X060-HP808	31156748
6,00	0,3	25	6	60	6,9	5,9	-	-	-	-	-	TCR107-060-0030-2500X060-HP808	31156749
6,00	0,3	30	6	75	6,9	5,9	-	-	-	-	-	TCR107-060-0030-3000X075-HP808	31156750
6,00	0,3	35	6	75	6,9	5,9	-	-	-	-	-	TCR107-060-0030-3500X075-HP808	31156751
6,00	0,5	15	6	60	6,9	5,9	-	-	-	-	-	TCR107-060-0050-1500X060-HP808	31156752
6,00	0,5	20	6	60	6,9	5,9	-	-	-	-	-	TCR107-060-0050-2000X060-HP808	31156753
6,00	0,5	25	6	60	6,9	5,9	-	-	-	-	-	TCR107-060-0050-2500X060-HP808	31156754
6,00	0,5	30	6	75	6,9	5,9	-	-	-	-	-	TCR107-060-0050-3000X075-HP808	31156755
6,00	0,5	35	6	75	6,9	5,9	-	-	-	-	-	TCR107-060-0050-3500X075-HP808	31156756
6,00	1	15	6	60	6,9	5,9	-	-	-	-	-	TCR107-060-0100-1500X060-HP808	31156757
6,00	1	20	6	60	6,9	5,9	-	-	-	-	-	TCR107-060-0100-2000X060-HP808	31156758
6,00	1	25	6	60	6,9	5,9	-	-	-	-	-	TCR107-060-0100-2500X060-HP808	31156759
6,00	1	30	6	75	6,9	5,9	-	-	-	-	-	TCR107-060-0100-3000X075-HP808	31156760
6,00	1	35	6	75	6,9	5,9	-	-	-	-	-	TCR107-060-0100-3500X075-HP808	31156761
8,00	0,5	25	8	64	9,2	7,8	-	-	-	-	-	TCR107-080-0050-2500X064-HP808	31156762
8,00	0,5	50	8	100	9,2	7,8	-	-	-	-	-	TCR107-080-0050-5000X100-HP808	31156763
8,00	1	25	8	64	9,2	7,8	-	-	-	-	-	TCR107-080-0100-2500X064-HP808	31156764
8,00	1	50	8	100	9,2	7,8	-	-	-	-	-	TCR107-080-0100-5000X100-HP808	31156765
8,00	2	25	8	64	9,2	7,8	-	-	-	-	-	TCR107-080-0200-2500X064-HP808	31156766
8,00	2	50	8	100	9,2	7,8	-	-	-	-	-	TCR107-080-0200-5000X100-HP808	31156767
10,00	0,5	30	10	75	11,5	9,8	-	-	-	-	-	TCR107-100-0050-3000X075-HP808	31156768
10,00	0,5	50	10	100	11,5	9,8	-	-	-	-	-	TCR107-100-0050-5000X100-HP808	31156769
10,00	1	30	10	75	11,5	9,8	-	-	-	-	-	TCR107-100-0100-3000X075-HP808	31156770
10,00	1	50	10	100	11,5	9,8	-	-	-	-	-	TCR107-100-0100-5000X100-HP808	31156771
10,00	2	30	10	75	11,5	9,8	-	-	-	-	-	TCR107-100-0200-3000X075-HP808	31156772
10,00	2	50	10	100	11,5	9,8	-	-	-	-	-	TCR107-100-0200-5000X100-HP808	31156773
12,00	0,5	35	12	75	13,8	11,8	-	-	-	-	-	TCR107-120-0050-3500X075-HP808	31156774
12,00	0,5	60	12	100	13,8	11,8	-	-	-	-	-	TCR107-120-0050-6000X100-HP808	31156775
12,00	1	35	12	75	13,8	11,8	-	-	-	-	-	TCR107-120-0100-3500X075-HP808	31156776
12,00	1	60	12	100	13,8	11,8	-	-	-	-	-	TCR107-120-0100-6000X100-HP808	31156777
12,00	2	35	12	75	13,8	11,8	-	-	-	-	-	TCR107-120-0200-3500X075-HP808	31156778
12,00	2	60	12	100	13,8	11,8	-	-	-	-	-	TCR107-120-0200-6000X100-HP808	31156779

## Auf Anfrage erhältlich

Baumaße							Arbeitstiefe bei x° Formschräge				Typ	Spezifikation	Bestell-Nr.
d <sub>1</sub>	R	l <sub>3</sub>	d <sub>2</sub> h5	l <sub>1</sub>	l <sub>2</sub>	d <sub>3</sub>	0,5°	1°	1,5°	3°			
0,10	0,02	0,3	6	60	0,1	0,075	0,56	0,60	0,64	0,75	A	TCR107-001-0002-0030X060-HP818	31156615
0,10	0,02	0,4	4	50	0,1	0,075	0,67	0,71	0,75	0,88	A	TCR107-001-0002-0040X050-HP818	31156616
0,10	0,02	0,4	6	60	0,1	0,075	0,67	0,71	0,75	0,88	A	TCR107-001-0002-0040X060-HP818	31156617
0,20	0,05	0,5	4	50	0,2	0,17	0,79	0,84	0,88	1,01	A	TCR107-002-0005-0050X050-HP818	31156618
0,20	0,05	0,75	4	50	0,2	0,17	1,06	1,12	1,17	1,31	A	TCR107-002-0005-0075X050-HP818	31156620
0,20	0,05	1	4	50	0,2	0,17	1,32	1,39	1,45	1,62	A	TCR107-002-0005-0100X050-HP818	31156621
0,20	0,05	1	6	60	0,2	0,17	1,32	1,39	1,45	1,62	A	TCR107-002-0005-0100X060-HP818	31156622
0,20	0,05	1,25	4	50	0,2	0,17	1,59	1,66	1,73	1,91	A	TCR107-002-0005-0125X050-HP818	31156623
0,20	0,05	1,5	4	50	0,2	0,17	1,85	1,94	2,01	2,20	A	TCR107-002-0005-0150X050-HP818	31156624
0,20	0,05	1,5	6	60	0,2	0,17	1,85	1,94	2,01	2,20	A	TCR107-002-0005-0150X060-HP818	31156625
0,30	0,05	0,75	4	50	0,3	0,27	1,06	1,12	1,17	1,31	A	TCR107-003-0005-0075X050-HP818	31156627
0,30	0,05	1	4	50	0,3	0,27	1,32	1,39	1,45	1,62	A	TCR107-003-0005-0100X050-HP818	31156628
0,30	0,05	1	6	60	0,3	0,27	1,32	1,39	1,45	1,62	A	TCR107-003-0005-0100X060-HP818	31156629
0,30	0,05	1,25	4	50	0,3	0,27	1,59	1,66	1,73	1,91	A	TCR107-003-0005-0125X050-HP818	31156630
0,30	0,05	1,5	4	50	0,3	0,27	1,85	1,94	2,01	2,20	A	TCR107-003-0005-0150X050-HP818	31156631
0,30	0,05	1,5	6	60	0,3	0,27	1,85	1,94	2,01	2,20	A	TCR107-003-0005-0150X060-HP818	31156632
0,30	0,05	2	6	60	0,3	0,27	2,37	2,48	2,56	2,78	A	TCR107-003-0005-0200X060-HP818	31156633
1,80	0,2	6	4	50	2,1	1,74	6,58	6,75	6,98	8,09	A	TCR107-018-0020-0600X050-HP818	31156681
1,80	0,2	8	4	50	2,1	1,74	8,64	8,85	9,26	10,74	A	TCR107-018-0020-0800X050-HP818	31156682
1,80	0,2	10	4	50	2,1	1,74	10,69	11,03	11,54	13,40	A	TCR107-018-0020-1000X050-HP818	31156683
1,80	0,2	15	4	50	2,1	1,74	15,80	16,48	17,24	20,03	A	TCR107-018-0020-1500X050-HP818	31156684
1,80	0,2	20	4	50	2,1	1,74	20,99	21,93	22,94	25,32	A	TCR107-018-0020-2000X050-HP818	31156685
2,50	0,5	25	6	75	2,9	2,44	26,74	27,40	28,60	33,21	A	TCR107-025-0050-2500X075-HP808	31156713

Maßangaben in mm.

Schnittwertempfehlung siehe Kapitelende.

Sonderausführungen und andere Beschichtungen auf Anfrage.

# OptiMill®-3D-CR-Hardened

Eckradiusfräser, Ausführung mit Hals, z=4  
TCR109

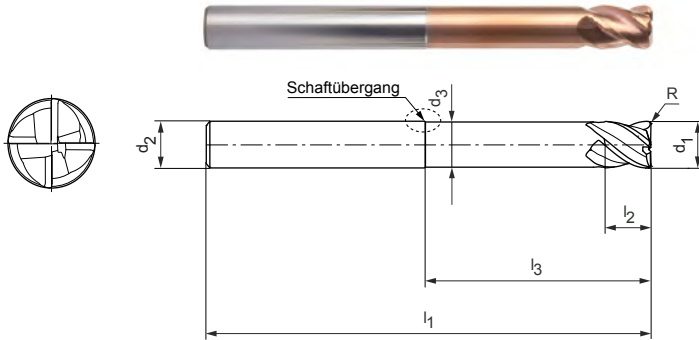

**Ausführung:**

Fräserdurchmesser: 3,00 - 12,00 mm  
 Schneidstoff: HP808  
 Schneidzahl: 4  
 Spiralwinkel: 42°  
 Toleranz Radiuskontur: ±0,005 wenn d<sub>1</sub> ≤ 6 mm  
 ±0,01 wenn d<sub>1</sub> > 6 mm

**Anwendung:**

Geeignet zur Bearbeitung von Werkstoffen bis 68 HRC.

**Schaftübergang:**

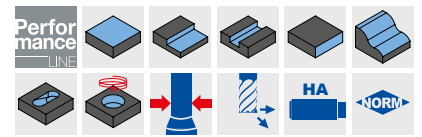
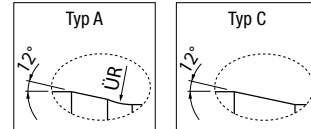

**Lagerhaltige Vorzugsbaureihe**

Baumaße							Arbeitstiefe bei x° Formschräge				Typ	Spezifikation	Bestell-Nr.
d <sub>1</sub>	R	l <sub>3</sub>	d <sub>2</sub> h <sub>5</sub>	l <sub>1</sub>	l <sub>2</sub>	d <sub>3</sub>	0,5°	1°	1,5°	3°			
3,00	0,2	10	6	60	3,5	2,94	11,22	11,64	11,99	13,40	A	TCR109-030-0020-1000X060-HP808	31156806
3,00	0,2	15	6	60	3,5	2,94	16,42	16,94	17,35	20,03	A	TCR109-030-0020-1500X060-HP808	31156807
3,00	0,2	20	6	60	3,5	2,94	21,60	22,19	22,94	26,67	A	TCR109-030-0020-2000X060-HP808	31156808
3,00	0,2	25	6	75	3,5	2,94	26,75	27,41	28,65	32,20	A	TCR109-030-0020-2500X075-HP808	31156809
3,00	0,5	10	6	60	3,5	2,94	11,21	11,63	11,96	13,30	A	TCR109-030-0050-1000X060-HP808	31156810
3,00	0,5	15	6	60	3,5	2,94	16,41	16,92	17,33	19,94	A	TCR109-030-0050-1500X060-HP808	31156811
3,00	0,5	20	6	60	3,5	2,94	21,59	22,18	22,90	26,57	A	TCR109-030-0050-2000X060-HP808	31156812
3,00	0,5	25	6	75	3,5	2,94	26,74	27,40	28,60	32,20	A	TCR109-030-0050-2500X075-HP808	31156813
4,00	0,2	10	6	60	4,6	3,94	11,22	11,64	11,99	13,40	A	TCR109-040-0020-1000X060-HP808	31156814
4,00	0,2	15	6	60	4,6	3,94	16,42	16,94	17,35	19,85	A	TCR109-040-0020-1500X060-HP808	31156815
4,00	0,2	20	6	60	4,6	3,94	21,60	22,19	22,94	24,85	A	TCR109-040-0020-2000X060-HP808	31156816
4,00	0,2	25	6	75	4,6	3,94	26,75	27,41	28,65	29,85	A	TCR109-040-0020-2500X075-HP808	31156817
4,00	0,2	30	6	75	4,6	3,94	31,89	32,82	34,35	34,85	A	TCR109-040-0020-3000X075-HP808	31156818
4,00	0,5	10	6	60	4,6	3,94	11,21	11,63	11,96	13,30	A	TCR109-040-0050-1000X060-HP808	31156819
4,00	0,5	15	6	60	4,6	3,94	16,41	16,92	17,33	19,85	A	TCR109-040-0050-1500X060-HP808	31156820
4,00	0,5	20	6	60	4,6	3,94	21,59	22,18	22,90	24,85	A	TCR109-040-0050-2000X060-HP808	31156821
4,00	0,5	25	6	75	4,6	3,94	26,74	27,40	28,60	29,85	A	TCR109-040-0050-2500X075-HP808	31156822
4,00	0,5	30	6	75	4,6	3,94	31,89	32,79	34,31	34,85	A	TCR109-040-0050-3000X075-HP808	31156823
5,00	0,2	15	6	60	5,8	4,9	15,88	16,58	17,35	17,59	C	TCR109-050-0020-1500X060-HP808	31156824
5,00	0,2	20	6	60	5,8	4,9	21,09	22,03	22,59	-	C	TCR109-050-0020-2000X060-HP808	31156825
5,00	0,2	25	6	60	5,8	4,9	26,31	27,48	27,59	-	C	TCR109-050-0020-2500X060-HP808	31156826
5,00	0,2	30	6	75	5,8	4,9	31,52	32,59	-	-	C	TCR109-050-0020-3000X075-HP808	31156827
5,00	0,5	15	6	60	5,8	4,9	15,87	16,55	17,31	17,59	C	TCR109-050-0050-1500X060-HP808	31156828
5,00	0,5	20	6	60	5,8	4,9	21,08	22,00	22,59	-	C	TCR109-050-0050-2000X060-HP808	31156829
5,00	0,5	25	6	60	5,8	4,9	26,29	27,45	27,59	-	C	TCR109-050-0050-2500X060-HP808	31156830
5,00	0,5	30	6	75	5,8	4,9	31,51	32,59	-	-	C	TCR109-050-0050-3000X075-HP808	31156831
6,00	0,2	15	6	60	6,9	5,9	-	-	-	-	-	TCR109-060-0020-1500X060-HP808	31156832
6,00	0,2	20	6	60	6,9	5,9	-	-	-	-	-	TCR109-060-0020-2000X060-HP808	31156833
6,00	0,2	25	6	60	6,9	5,9	-	-	-	-	-	TCR109-060-0020-2500X060-HP808	31156834
6,00	0,2	30	6	75	6,9	5,9	-	-	-	-	-	TCR109-060-0020-3000X075-HP808	31156835
6,00	0,2	35	6	75	6,9	5,9	-	-	-	-	-	TCR109-060-0020-3500X075-HP808	31156836
6,00	0,3	15	6	60	6,9	5,9	-	-	-	-	-	TCR109-060-0030-1500X060-HP808	31156837
6,00	0,3	20	6	60	6,9	5,9	-	-	-	-	-	TCR109-060-0030-2000X060-HP808	31156838
6,00	0,3	25	6	60	6,9	5,9	-	-	-	-	-	TCR109-060-0030-2500X060-HP808	31156839
6,00	0,3	30	6	75	6,9	5,9	-	-	-	-	-	TCR109-060-0030-3000X075-HP808	31156840



**OptiMill®-3D-CR-Hardened | TCR109 | Eckradiusfräser, Ausführung mit Hals, z=4**

Baumaße							Arbeitstiefe bei x° Formschräge				Typ	Spezifikation	Bestell-Nr.
d <sub>1</sub>	R	l <sub>3</sub>	d <sub>2</sub> h5	l <sub>1</sub>	l <sub>2</sub>	d <sub>3</sub>	0,5°	1°	1,5°	3°			
6,00	0,3	35	6	75	6,9	5,9	-	-	-	-	-	TCR109-060-0030-3500X075-HP808	31156841
6,00	0,5	15	6	60	6,9	5,9	-	-	-	-	-	TCR109-060-0050-1500X060-HP808	31156842
6,00	0,5	20	6	60	6,9	5,9	-	-	-	-	-	TCR109-060-0050-2000X060-HP808	31156843
6,00	0,5	25	6	60	6,9	5,9	-	-	-	-	-	TCR109-060-0050-2500X060-HP808	31156844
6,00	0,5	30	6	75	6,9	5,9	-	-	-	-	-	TCR109-060-0050-3000X075-HP808	31156845
6,00	0,5	35	6	75	6,9	5,9	-	-	-	-	-	TCR109-060-0050-3500X075-HP808	31156846
6,00	1	15	6	60	6,9	5,9	-	-	-	-	-	TCR109-060-0100-1500X060-HP808	31156847
6,00	1	20	6	60	6,9	5,9	-	-	-	-	-	TCR109-060-0100-2000X060-HP808	31156848
6,00	1	25	6	60	6,9	5,9	-	-	-	-	-	TCR109-060-0100-2500X060-HP808	31156849
6,00	1	30	6	75	6,9	5,9	-	-	-	-	-	TCR109-060-0100-3000X075-HP808	31156850
6,00	1	35	6	75	6,9	5,9	-	-	-	-	-	TCR109-060-0100-3500X075-HP808	31156851
8,00	0,5	25	8	64	9,2	7,8	-	-	-	-	-	TCR109-080-0050-2500X064-HP808	31156852
8,00	0,5	50	8	100	9,2	7,8	-	-	-	-	-	TCR109-080-0050-5000X100-HP808	31156855
8,00	1	25	8	64	9,2	7,8	-	-	-	-	-	TCR109-080-0100-2500X064-HP808	31156853
8,00	1	50	8	100	9,2	7,8	-	-	-	-	-	TCR109-080-0100-5000X100-HP808	31156856
8,00	2	25	8	64	9,2	7,8	-	-	-	-	-	TCR109-080-0200-2500X064-HP808	31156854
8,00	2	50	8	100	9,2	7,8	-	-	-	-	-	TCR109-080-0200-5000X100-HP808	31156857
10,00	0,5	30	10	75	11,5	9,8	-	-	-	-	-	TCR109-100-0050-3000X075-HP808	31156858
10,00	0,5	50	10	100	11,5	9,8	-	-	-	-	-	TCR109-100-0050-5000X100-HP808	31156861
10,00	1	30	10	75	11,5	9,8	-	-	-	-	-	TCR109-100-0100-3000X075-HP808	31156859
10,00	1	50	10	100	11,5	9,8	-	-	-	-	-	TCR109-100-0100-5000X100-HP808	31156862
10,00	2	30	10	75	11,5	9,8	-	-	-	-	-	TCR109-100-0200-3000X075-HP808	31156860
10,00	2	50	10	100	11,5	9,8	-	-	-	-	-	TCR109-100-0200-5000X100-HP808	31156863
12,00	0,5	35	12	75	13,8	11,8	-	-	-	-	-	TCR109-120-0050-3500X075-HP808	31156864
12,00	0,5	60	12	100	13,8	11,8	-	-	-	-	-	TCR109-120-0050-6000X100-HP808	31156867
12,00	1	35	12	75	13,8	11,8	-	-	-	-	-	TCR109-120-0100-3500X075-HP808	31156865
12,00	1	60	12	100	13,8	11,8	-	-	-	-	-	TCR109-120-0100-6000X100-HP808	31156868
12,00	2	35	12	75	13,8	11,8	-	-	-	-	-	TCR109-120-0200-3500X075-HP808	31156866
12,00	2	60	12	100	13,8	11,8	-	-	-	-	-	TCR109-120-0200-6000X100-HP808	31156869

Maßangaben in mm.

Schnittwertempfehlung siehe Kapitelende.

Sonderausführungen und andere Beschichtungen auf Anfrage.

# OptiMill®-3D-CR-Alu

Eckradiusfräser, Ausführung mit Hals, z=2  
TCR120

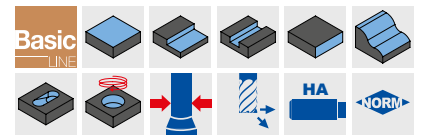
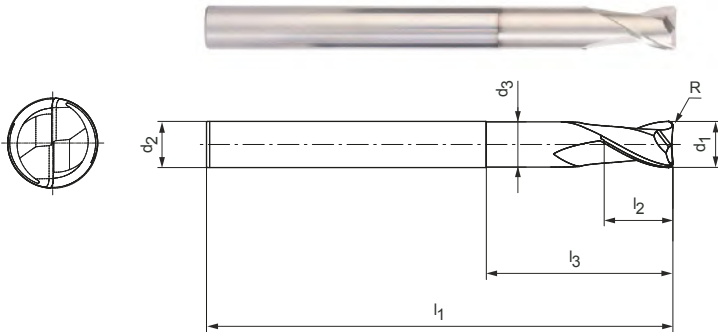

## Ausführung:

Fräserdurchmesser: 2,00 - 20,00 mm  
Schneidstoff: HP807  
Schneidzahl: 2  
Spiralwinkel: 30°  
Toleranz Radiuskontur: R = ±0,01

## Anwendung:

Geeignet zur Bearbeitung von hochfesten Aluminiumlegierungen.

## Lagerhaltige Vorzugsbaureihe

Baumaße							z	Spezifikation	Bestell-Nr.
d <sub>1</sub>	R	l <sub>3</sub>	d <sub>2</sub> h5	l <sub>1</sub>	l <sub>2</sub>	d <sub>3</sub>			
2,00	0,2	10	4	50	2	1,9	2	TCR120-020-0020-1000X050-HP807	31155300
2,00	0,5	10	4	50	2	1,9	2	TCR120-020-0050-1000X050-HP807	31155302
3,00	0,2	12	4	50	3	2,9	2	TCR120-030-0020-1200X050-HP807	31155303
3,00	0,5	12	4	50	3	2,9	2	TCR120-030-0050-1200X050-HP807	31155304
4,00	0,2	15	4	50	4	3,8	2	TCR120-040-0020-1500X050-HP807	31155305
4,00	0,5	15	4	50	4	3,8	2	TCR120-040-0050-1500X050-HP807	31155306
5,00	0,2	21	6	57	5	4,8	2	TCR120-050-0020-2100X057-HP807	31155307
5,00	0,5	21	6	57	5	4,8	2	TCR120-050-0050-2100X057-HP807	31155308
6,00	0,2	21	6	57	6	5,8	2	TCR120-060-0020-2100X057-HP807	31155309
6,00	0,5	21	6	57	6	5,8	2	TCR120-060-0050-2100X057-HP807	31155310
6,00	1	21	6	57	6	5,8	2	TCR120-060-0100-2100X057-HP807	31155311
6,00	1	30	6	75	6	5,8	2	TCR120-060-0100-3000X075-HP807	31155312
8,00	0,5	27	8	63	8	7,8	2	TCR120-080-0050-2700X063-HP807	31155313
8,00	1	30	8	63	8	7,8	2	TCR120-080-0100-3000X063-HP807	31155314
8,00	1	50	8	90	8	7,8	2	TCR120-080-0100-5000X090-HP807	31155315
10,00	0,5	32	10	72	10	9,8	2	TCR120-100-0050-3200X072-HP807	31155317
10,00	1	32	10	72	10	9,8	2	TCR120-100-0100-3200X072-HP807	31155318
10,00	1	40	10	100	10	9,8	2	TCR120-100-0100-4000X100-HP807	31155319
10,00	1	60	10	100	10	9,8	2	TCR120-100-0100-6000X100-HP807	31155320
10,00	1,5	32	10	72	10	9,8	2	TCR120-100-0150-3200X072-HP807	31155321
12,00	0,5	38	12	83	12	11,8	2	TCR120-120-0050-3800X083-HP807	31155323
12,00	1,5	38	12	83	12	11,8	2	TCR120-120-0150-3800X083-HP807	31155324
12,00	1,5	60	12	110	12	11,8	2	TCR120-120-0150-6000X110-HP807	31155325
12,00	1,5	80	12	110	12	11,8	2	TCR120-120-0150-8000X110-HP807	31155326
16,00	2	44	16	92	16	15,8	2	TCR120-160-0200-4400X092-HP807	31155329
20,00	2	54	20	104	20	19,8	2	TCR120-200-0200-5400X104-HP807	31155331

## Auf Anfrage erhältlich

16,00	1,5	50	16	92	16	15,8	2	TCR120-160-0150-5000X092-HP807	31155327
16,00	1,5	100	16	150	16	15,8	2	TCR120-160-0150-1000X150-HP807	31155328
20,00	1,5	100	20	150	20	19,8	2	TCR120-200-0150-1000X150-HP807	31155330

Maßangaben in mm.

Schnittwertempfehlung siehe Kapitelende.

Sonderausführungen und andere Beschichtungen auf Anfrage.

# OptiMill®-Composite-Speed-Radius

Kugelfräser, Ausführung mit ziehender Schneide, mit Vollradius  
M7828

**Ausführung:**

Fräserdurchmesser: 4,00 - 20,00 mm  
Beschichtung: HC611/HC619  
Schneidenzahl: 8  
Spiralwinkel: 8°  
Besonderheiten: Diamantbeschichtung für hohe Standzeit.

**Anwendung:**

Ziehende Schneide für eine bessere Abfuhr der Späne/Stäube (z. B. beim Fräsen von Taschen und Nuten). Besonders geeignet für schwer zerspanbare Decklagen (z. B. UD oder Copper Mesh) zur Vermeidung von Delamination an der Bauteilunterkante.

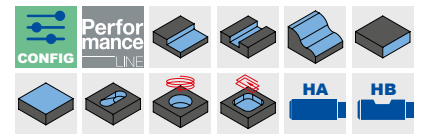
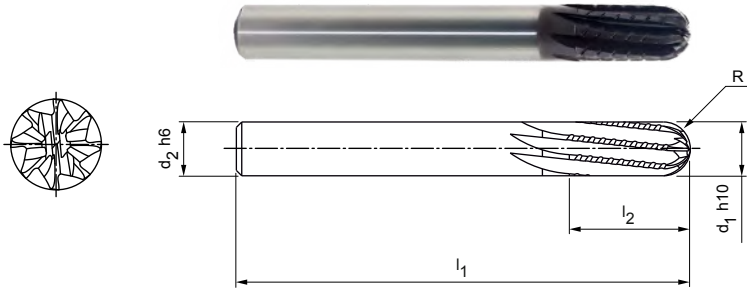

**Lagerhaltige Vorzugsbaureihe**

Baumaße					z	Spezifikation	Bestell-Nr.
d <sub>1</sub> h10	d <sub>2</sub> h6	l <sub>1</sub>	l <sub>2</sub>	R			
4,00	6	60	16	2	8	M7828-0400AQ-FC8-R0200	30869232
6,00	6	75	28	3	8	M7828-0600AQ-FC8-R0300	30869236
8,00	8	75	32	4	8	M7828-0800AQ-FC8-R0400	30869238
10,00	10	72	32	5	8	M7828-1000AQ-FC8-R0500	30869239

**Auf Anfrage erhältlich**

12,00	12	83	32	6	8	M7828-1200AQ-FC8-R0600	30869240
16,00	16	92	36	8	8	M7828-1600AQ-FC8-R0800	30869241
20,00	20	104	45	10	8	M7828-2000AQ-FC8-R1000	30869242

**Konfigurierbare Merkmale**



**Schaftform:**  
Schaftform: HB



**Spezifikation:**  
M7828-1000[Schaftform]Q-FC8-R0500

**Beispiel:**

M7828-1000**B**Q-FC8-R0500

Schaftform HB

Maßangaben in mm.

Schnittwertempfehlung siehe Kapitelende.

Sonderausführungen und andere Beschichtungen auf Anfrage.

# Schnittwertempfehlung für Eckradiusfräser

Vorschub und Schnittgeschwindigkeit

## OptiMill-3D-CR | TCR101, TCR104

MZG*	Werkstoff	Festigkeit/Härte [N/mm <sup>2</sup> ] [HRC]	Kühlung			
			Trocken	Luft/MMS	KSS	
P	P1.1	Bau-, Automaten-, Einsatz- und Vergütungsstähle, unlegiert	< 700	✓	✓	✓
	P1.2	Bau-, Automaten-, Einsatz- und Vergütungsstähle, unlegiert	< 1.200	✓	✓	✓
	P2.1	Nitrier-, Einsatz- und Vergütungsstähle, legiert	< 900	✓	✓	✓
	P2.2	Nitrier-, Einsatz- und Vergütungsstähle, legiert	< 1.400	✓	✓	✓
	P3.1	Werkzeug-, Wälzlager-, Feder- und Schnellarbeitsstähle**	< 800	✓	✓	✓
	P3.2	Werkzeug-, Wälzlager-, Feder- und Schnellarbeitsstähle**	< 1.000	✓	✓	✓
	P3.3	Werkzeug-, Wälzlager-, Feder- und Schnellarbeitsstähle**	< 1.500	✓	✓	✓
	P4.1	Rostfreie Stähle, ferritisch und martensitisch			✓	✓
	P5.1	Stahlguss			✓	✓
	P6.1	Rostfreier Stahlguss, ferritisch und martensitisch			✓	✓
M	M1.1	Rostfreie Stähle, austenitisch	< 700			✓
	M1.2	Rostfreie Stähle, ferritisch/austenitisch (Duplex)	< 1.000			✓
	M2.1	Rostfreier Stahlguss, austenitisch	< 700			✓
	M3.1	Rostfreier Stahlguss, ferritisch/austenitisch (Duplex)	< 1.000			✓
K	K1.1	Gusseisen mit Lamellengraphit (Grauguss), GJL	< 300	✓	✓	✓
	K2.1	Gusseisen mit Kugelgraphit, GJS	< 500	✓	✓	✓
	K2.2	Gusseisen mit Kugelgraphit, GJS	≤ 800	✓	✓	✓
	K2.3	Gusseisen mit Kugelgraphit, GJS	> 800	✓	✓	✓
	K3.1	Gusseisen mit Vermiculargraphit, GJV; Temperguss, GJM	< 500	✓	✓	✓
	K3.2	Gusseisen mit Vermiculargraphit, GJV; Temperguss, GJM	> 500	✓	✓	✓
H	H1.1	Gehärteter Stahl/Stahlguss	< 44 HRC	✓	✓	
	H1.2	Gehärteter Stahl/Stahlguss	< 55 HRC	✓	✓	
	H2.1	Gehärteter Stahl/Stahlguss	< 60 HRC		✓	

### Korrekturfaktor Arbeitstiefe - $k_{AT}$

AT	$k_{AT}$		
	$a_p$	n	$v_f$
≤ 3xD	1,00	1,00	1,00
≤ 5xD	0,80	0,90	0,90
≤ 6xD	0,70	0,85	0,85
≤ 8xD	0,60	0,75	0,75
≤ 10xD	0,50	0,70	0,70
≤ 12xD	0,45***	0,65	0,65
≤ 15xD	0,40***	0,60	0,60
≤ 20xD	0,35***	0,60	0,60
≤ 25xD	0,35***	0,50	0,50
≤ 30xD	0,30***	0,50	0,50
≤ 35xD	0,30***	0,50	0,50

### Korrekturfaktor Konuswinkel - $k_{KW}$

$\varphi$ [°]	$k_{KW}$		
	$a_p$	n	$v_f$
0	1,00	1,00	1,00
0,5	1,01	1,01	1,01
1	1,02	1,02	1,02
1,5	1,03	1,03	1,03
3	1,06	1,06	1,06

#### Hinweis:

Für die Ermittlung der Schnittwerte bitte die Hinweise auf den Seiten 520-523 beachten.

\* MILLER Zerspanungsgruppen

\*\* Wenn die Legierungsbestandteile Cr, Mo, Ni, V, W in Summe > 8 %, dann die nächst höhere MILLER Zerspanungsgruppe wählen.

\*\*\* Rücksprache mit einem MILLER Anwendungstechniker.

Schruppen

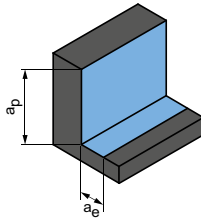

Eintauchwinkel  
1,0° - 3,0°

Nächste Seite:  
**Schichten (3D, Abzeilen)**

ap [mm]	ae [mm]	vc [m/min]	fz [mm]																		
			Fräserdurchmesser [mm]																		
			0,10	0,20	0,30	0,40	0,50	0,60	0,80	1,00	1,50	1,80	2,00	2,50	3,00	4,00	5,00	6,00	8,00	10,00	12,00
0,15xD	0,45xD	<b>250-300</b>	0,003	0,004	0,006	0,008	0,010	0,012	0,016	0,020	0,028	0,035	0,040	0,050	0,061	0,084	0,107	0,125	0,165	0,200	0,235
0,15xD	0,45xD	<b>240-280</b>	0,003	0,004	0,005	0,007	0,009	0,011	0,014	0,018	0,025	0,031	0,035	0,044	0,054	0,074	0,094	0,110	0,145	0,176	0,207
0,15xD	0,45xD	<b>250-300</b>	0,003	0,004	0,006	0,008	0,010	0,012	0,016	0,020	0,028	0,035	0,040	0,050	0,061	0,084	0,107	0,125	0,165	0,200	0,235
0,15xD	0,45xD	<b>240-280</b>	0,003	0,004	0,005	0,007	0,009	0,011	0,014	0,018	0,025	0,031	0,035	0,044	0,054	0,074	0,094	0,110	0,145	0,176	0,207
0,15xD	0,45xD	<b>250-300</b>	0,003	0,004	0,006	0,008	0,010	0,011	0,015	0,019	0,027	0,033	0,038	0,048	0,058	0,080	0,102	0,119	0,157	0,190	0,223
0,15xD	0,45xD	<b>240-280</b>	0,003	0,004	0,005	0,007	0,009	0,011	0,014	0,018	0,025	0,031	0,035	0,044	0,054	0,074	0,094	0,110	0,145	0,176	0,207
0,15xD	0,45xD	<b>220-260</b>	0,002	0,003	0,004	0,006	0,007	0,009	0,012	0,015	0,020	0,026	0,029	0,037	0,045	0,061	0,078	0,091	0,120	0,146	0,172
0,15xD	0,45xD	<b>240-280</b>	0,003	0,004	0,006	0,008	0,010	0,012	0,016	0,020	0,028	0,035	0,040	0,050	0,061	0,084	0,107	0,125	0,165	0,200	0,235
0,15xD	0,45xD	<b>240-280</b>	0,003	0,004	0,005	0,007	0,009	0,011	0,014	0,018	0,025	0,031	0,035	0,044	0,054	0,074	0,094	0,110	0,145	0,176	0,207
0,15xD	0,45xD	<b>200-250</b>	0,002	0,003	0,004	0,006	0,007	0,009	0,012	0,015	0,020	0,026	0,029	0,037	0,045	0,061	0,078	0,091	0,120	0,146	0,172
0,1xD	0,4xD	<b>85-110</b>	0,003	0,004	0,005	0,007	0,009	0,011	0,014	0,018	0,025	0,031	0,035	0,044	0,054	0,074	0,094	0,110	0,145	0,176	0,207
0,1xD	0,4xD	<b>60-85</b>	0,002	0,003	0,004	0,006	0,007	0,009	0,012	0,015	0,020	0,026	0,029	0,037	0,045	0,061	0,078	0,091	0,120	0,146	0,172
0,1xD	0,4xD	<b>85-110</b>	0,003	0,004	0,005	0,007	0,009	0,011	0,014	0,018	0,025	0,031	0,035	0,044	0,054	0,074	0,094	0,110	0,145	0,176	0,207
0,1xD	0,4xD	<b>60-85</b>	0,002	0,003	0,004	0,006	0,007	0,009	0,012	0,015	0,020	0,026	0,029	0,037	0,045	0,061	0,078	0,091	0,120	0,146	0,172
0,15xD	0,55xD	<b>250-300</b>	0,004	0,005	0,007	0,010	0,012	0,014	0,019	0,024	0,034	0,042	0,048	0,060	0,073	0,101	0,128	0,150	0,198	0,240	0,282
0,15xD	0,55xD	<b>250-300</b>	0,003	0,004	0,006	0,008	0,010	0,012	0,016	0,020	0,028	0,035	0,040	0,050	0,061	0,084	0,107	0,125	0,165	0,200	0,235
0,15xD	0,55xD	<b>240-280</b>	0,003	0,004	0,006	0,008	0,010	0,012	0,016	0,020	0,028	0,035	0,040	0,050	0,061	0,084	0,107	0,125	0,165	0,200	0,235
0,15xD	0,55xD	<b>240-280</b>	0,003	0,004	0,005	0,007	0,009	0,011	0,014	0,018	0,025	0,031	0,035	0,044	0,054	0,074	0,094	0,110	0,145	0,176	0,207
0,15xD	0,55xD	<b>250-300</b>	0,002	0,003	0,004	0,006	0,007	0,009	0,012	0,015	0,020	0,026	0,029	0,037	0,045	0,061	0,078	0,091	0,120	0,146	0,172
0,15xD	0,55xD	<b>240-280</b>	0,002	0,002	0,004	0,005	0,006	0,007	0,010	0,012	0,017	0,022	0,025	0,031	0,038	0,052	0,066	0,078	0,102	0,124	0,146
0,06xD	0,35xD	<b>200-240</b>	0,002	0,003	0,004	0,006	0,007	0,009	0,012	0,015	0,020	0,026	0,029	0,037	0,045	0,061	0,078	0,091	0,120	0,146	0,172
0,05xD	0,3xD	<b>140-200</b>	0,002	0,002	0,004	0,005	0,006	0,007	0,010	0,012	0,017	0,021	0,024	0,030	0,037	0,050	0,064	0,075	0,099	0,120	0,141
0,025xD	0,25xD	<b>100-140</b>	0,001	0,002	0,002	0,003	0,004	0,005	0,006	0,008	0,011	0,014	0,016	0,020	0,024	0,034	0,043	0,050	0,066	0,080	0,094

Die angegebenen Arbeitswerte sind Richtwerte.

Die für den jeweiligen Bearbeitungsfall optimalen Daten sollten im Versuch oder während der Bearbeitung ermittelt werden.

# Schnittwertempfehlung für Eckradiusfräser

Vorschub und Schnittgeschwindigkeit

## OptiMill-3D-CR | TCR101, TCR104

MZG*	Werkstoff	Festigkeit/Härte [N/mm <sup>2</sup> ] [HRC]	Kühlung			
			Trocken	Luft/MMS	KSS	
P	P1.1	Bau-, Automaten-, Einsatz- und Vergütungsstähle, unlegiert	< 700	✓	✓	✓
	P1.2	Bau-, Automaten-, Einsatz- und Vergütungsstähle, unlegiert	< 1.200	✓	✓	✓
	P2.1	Nitrier-, Einsatz- und Vergütungsstähle, legiert	< 900	✓	✓	✓
	P2.2	Nitrier-, Einsatz- und Vergütungsstähle, legiert	< 1.400	✓	✓	✓
	P3.1	Werkzeug-, Wälzlager-, Feder- und Schnellarbeitsstähle**	< 800	✓	✓	✓
	P3.2	Werkzeug-, Wälzlager-, Feder- und Schnellarbeitsstähle**	< 1.000	✓	✓	✓
	P3.3	Werkzeug-, Wälzlager-, Feder- und Schnellarbeitsstähle**	< 1.500	✓	✓	✓
	P4.1	Rostfreie Stähle, ferritisch und martensitisch			✓	✓
	P5.1	Stahlguss			✓	✓
	P6.1	Rostfreier Stahlguss, ferritisch und martensitisch			✓	✓
M	M1.1	Rostfreie Stähle, austenitisch	< 700			✓
	M1.2	Rostfreie Stähle, ferritisch/austenitisch (Duplex)	< 1.000			✓
	M2.1	Rostfreier Stahlguss, austenitisch	< 700			✓
	M3.1	Rostfreier Stahlguss, ferritisch/austenitisch (Duplex)	< 1.000			✓
K	K1.1	Gusseisen mit Lamellengraphit (Grauguss), GJL	< 300	✓	✓	✓
	K2.1	Gusseisen mit Kugelgraphit, GJS	< 500	✓	✓	✓
	K2.2	Gusseisen mit Kugelgraphit, GJS	≤ 800	✓	✓	✓
	K2.3	Gusseisen mit Kugelgraphit, GJS	> 800	✓	✓	✓
	K3.1	Gusseisen mit Vermiculargraphit, GJV; Temperguss, GJM	< 500	✓	✓	✓
	K3.2	Gusseisen mit Vermiculargraphit, GJV; Temperguss, GJM	> 500	✓	✓	✓
H	H1.1	Gehärteter Stahl/Stahlguss	< 44 HRC	✓	✓	
	H1.2	Gehärteter Stahl/Stahlguss	< 55 HRC	✓	✓	
	H2.1	Gehärteter Stahl/Stahlguss	< 60 HRC		✓	

### Korrekturfaktor Arbeitstiefe - $k_{AT}$

AT	$k_{AT}$		
	$a_p$	n	$v_f$
≤ 3xD	1,00	1,00	1,00
≤ 5xD	0,80	0,90	0,90
≤ 6xD	0,70	0,85	0,85
≤ 8xD	0,60	0,75	0,75
≤ 10xD	0,50	0,70	0,70
≤ 12xD	0,45***	0,65	0,65
≤ 15xD	0,40***	0,60	0,60
≤ 20xD	0,35***	0,60	0,60
≤ 25xD	0,35***	0,50	0,50
≤ 30xD	0,30***	0,50	0,50
≤ 35xD	0,30***	0,50	0,50

### Korrekturfaktor Konuswinkel - $k_{KW}$

$\varphi$ [°]	$k_{KW}$		
	$a_p$	n	$v_f$
0	1,00	1,00	1,00
0,5	1,01	1,01	1,01
1	1,02	1,02	1,02
1,5	1,03	1,03	1,03
3	1,06	1,06	1,06

#### Hinweis:

Für die Ermittlung der Schnittwerte bitte die Hinweise auf den Seiten 520-523 beachten.

\* MILLER Zerspanungsgruppen

\*\* Wenn die Legierungsbestandteile Cr, Mo, Ni, V, W in Summe > 8 %, dann die nächst höhere MILLER Zerspanungsgruppe wählen.

\*\*\* Rücksprache mit einem MILLER Anwendungstechniker.

Schichten  
(3D, Abzeilen)

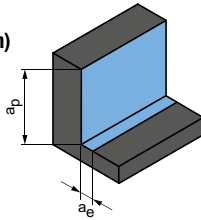

Nächste Seite:  
Schichten (ebene Bereiche)

	a <sub>p</sub> [mm]	a <sub>e</sub> [mm]	v <sub>c</sub> [m/min]	f <sub>z</sub> [mm]																	
				Fräserdurchmesser [mm]																	
				0,10	0,20	0,30	0,40	0,50	0,60	0,80	1,00	1,50	1,80	2,00	2,50	3,00	4,00	5,00	6,00	8,00	10,00
0,012xD	0,022xD	<b>280-340</b>	0,003	0,004	0,006	0,008	0,010	0,011	0,015	0,019	0,027	0,033	0,038	0,048	0,058	0,080	0,102	0,119	0,157	0,190	0,223
0,012xD	0,022xD	<b>280-320</b>	0,003	0,003	0,005	0,007	0,008	0,010	0,013	0,017	0,023	0,029	0,033	0,042	0,051	0,070	0,089	0,105	0,138	0,167	0,196
0,012xD	0,022xD	<b>270-320</b>	0,003	0,004	0,006	0,008	0,010	0,011	0,015	0,019	0,027	0,033	0,038	0,048	0,058	0,080	0,102	0,119	0,157	0,190	0,223
0,012xD	0,022xD	<b>260-300</b>	0,003	0,003	0,005	0,007	0,008	0,010	0,013	0,017	0,023	0,029	0,033	0,042	0,051	0,070	0,089	0,105	0,138	0,167	0,196
0,012xD	0,022xD	<b>280-320</b>	0,003	0,004	0,005	0,007	0,009	0,011	0,014	0,018	0,025	0,032	0,036	0,045	0,055	0,076	0,097	0,113	0,149	0,181	0,212
0,012xD	0,022xD	<b>260-300</b>	0,003	0,003	0,005	0,007	0,008	0,010	0,013	0,017	0,023	0,029	0,033	0,042	0,051	0,070	0,089	0,105	0,138	0,167	0,196
0,012xD	0,022xD	<b>240-280</b>	0,002	0,003	0,004	0,006	0,007	0,008	0,011	0,014	0,019	0,024	0,028	0,035	0,042	0,058	0,074	0,087	0,114	0,139	0,163
0,012xD	0,022xD	<b>260-300</b>	0,003	0,004	0,006	0,008	0,010	0,011	0,015	0,019	0,027	0,033	0,038	0,048	0,058	0,080	0,102	0,119	0,157	0,190	0,223
0,012xD	0,022xD	<b>260-300</b>	0,003	0,003	0,005	0,007	0,008	0,010	0,013	0,017	0,023	0,029	0,033	0,042	0,051	0,070	0,089	0,105	0,138	0,167	0,196
0,012xD	0,022xD	<b>220-270</b>	0,002	0,003	0,004	0,006	0,007	0,008	0,011	0,014	0,019	0,024	0,028	0,035	0,042	0,058	0,074	0,087	0,114	0,139	0,163
0,013xD	0,023xD	<b>90-120</b>	0,003	0,003	0,005	0,007	0,008	0,010	0,013	0,017	0,023	0,029	0,033	0,042	0,051	0,070	0,089	0,105	0,138	0,167	0,196
0,012xD	0,022xD	<b>70-90</b>	0,002	0,003	0,004	0,006	0,007	0,008	0,011	0,014	0,019	0,024	0,028	0,035	0,042	0,058	0,074	0,087	0,114	0,139	0,163
0,013xD	0,023xD	<b>90-120</b>	0,003	0,003	0,005	0,007	0,008	0,010	0,013	0,017	0,023	0,029	0,033	0,042	0,051	0,070	0,089	0,105	0,138	0,167	0,196
0,012xD	0,022xD	<b>70-90</b>	0,002	0,003	0,004	0,006	0,007	0,008	0,011	0,014	0,019	0,024	0,028	0,035	0,042	0,058	0,074	0,087	0,114	0,139	0,163
0,012xD	0,022xD	<b>280-340</b>	0,003	0,004	0,006	0,008	0,010	0,011	0,015	0,019	0,027	0,033	0,038	0,048	0,058	0,080	0,102	0,119	0,157	0,190	0,223
0,012xD	0,022xD	<b>280-320</b>	0,003	0,003	0,005	0,007	0,008	0,010	0,013	0,017	0,023	0,029	0,033	0,042	0,051	0,070	0,089	0,105	0,138	0,167	0,196
0,012xD	0,022xD	<b>270-320</b>	0,003	0,003	0,005	0,007	0,008	0,010	0,013	0,017	0,023	0,029	0,033	0,042	0,051	0,070	0,089	0,105	0,138	0,167	0,196
0,012xD	0,022xD	<b>260-300</b>	0,003	0,003	0,005	0,007	0,008	0,010	0,013	0,017	0,023	0,029	0,033	0,042	0,051	0,070	0,089	0,105	0,138	0,167	0,196
0,012xD	0,022xD	<b>280-320</b>	0,002	0,003	0,004	0,006	0,007	0,008	0,011	0,014	0,019	0,024	0,028	0,035	0,042	0,058	0,074	0,087	0,114	0,139	0,163
0,012xD	0,022xD	<b>260-300</b>	0,002	0,002	0,004	0,005	0,006	0,007	0,009	0,012	0,017	0,021	0,024	0,029	0,036	0,050	0,063	0,074	0,097	0,118	0,139
0,012xD	0,022xD	<b>220-250</b>	0,002	0,003	0,004	0,006	0,007	0,009	0,012	0,014	0,020	0,025	0,029	0,036	0,044	0,061	0,077	0,090	0,119	0,144	0,170
0,01xD	0,02xD	<b>170-220</b>	0,002	0,003	0,004	0,005	0,007	0,008	0,011	0,014	0,019	0,024	0,027	0,034	0,042	0,058	0,073	0,086	0,113	0,137	0,161
0,01xD	0,02xD	<b>120-170</b>	0,001	0,002	0,003	0,004	0,005	0,006	0,008	0,010	0,013	0,017	0,019	0,024	0,029	0,040	0,051	0,060	0,079	0,096	0,113

Die angegebenen Arbeitswerte sind Richtwerte.  
Die für den jeweiligen Bearbeitungsfall optimalen Daten sollten im Versuch oder während der Bearbeitung ermittelt werden.

# Schnittwertempfehlung für Eckradiusfräser

Vorschub und Schnittgeschwindigkeit

## OptiMill-3D-CR | TCR101, TCR104

MZG*	Werkstoff	Festigkeit/Härte [N/mm <sup>2</sup> ] [HRC]	Kühlung			
			Trocken	Luft/MMS	KSS	
P	P1.1	Bau-, Automaten-, Einsatz- und Vergütungsstähle, unlegiert	< 700	✓	✓	✓
	P1.2	Bau-, Automaten-, Einsatz- und Vergütungsstähle, unlegiert	< 1.200	✓	✓	✓
	P2.1	Nitrier-, Einsatz- und Vergütungsstähle, legiert	< 900	✓	✓	✓
	P2.2	Nitrier-, Einsatz- und Vergütungsstähle, legiert	< 1.400	✓	✓	✓
	P3.1	Werkzeug-, Wälzlager-, Feder- und Schnellarbeitsstähle**	< 800	✓	✓	✓
	P3.2	Werkzeug-, Wälzlager-, Feder- und Schnellarbeitsstähle**	< 1.000	✓	✓	✓
	P3.3	Werkzeug-, Wälzlager-, Feder- und Schnellarbeitsstähle**	< 1.500	✓	✓	✓
	P4.1	Rostfreie Stähle, ferritisch und martensitisch			✓	✓
	P5.1	Stahlguss			✓	✓
	P6.1	Rostfreier Stahlguss, ferritisch und martensitisch			✓	✓
M	M1.1	Rostfreie Stähle, austenitisch	< 700			✓
	M1.2	Rostfreie Stähle, ferritisch/austenitisch (Duplex)	< 1.000			✓
	M2.1	Rostfreier Stahlguss, austenitisch	< 700			✓
	M3.1	Rostfreier Stahlguss, ferritisch/austenitisch (Duplex)	< 1.000			✓
K	K1.1	Gusseisen mit Lamellengraphit (Grauguss), GJL	< 300	✓	✓	✓
	K2.1	Gusseisen mit Kugelgraphit, GJS	< 500	✓	✓	✓
	K2.2	Gusseisen mit Kugelgraphit, GJS	≤ 800	✓	✓	✓
	K2.3	Gusseisen mit Kugelgraphit, GJS	> 800	✓	✓	✓
	K3.1	Gusseisen mit Vermiculargraphit, GJV; Temperguss, GJM	< 500	✓	✓	✓
	K3.2	Gusseisen mit Vermiculargraphit, GJV; Temperguss, GJM	> 500	✓	✓	✓
H	H1.1	Gehärteter Stahl/Stahlguss	< 44 HRC	✓	✓	
	H1.2	Gehärteter Stahl/Stahlguss	< 55 HRC	✓	✓	
	H2.1	Gehärteter Stahl/Stahlguss	< 60 HRC		✓	

### Korrekturfaktor Arbeitstiefe - $k_{AT}$

AT	$k_{AT}$		
	$a_p$	n	$v_f$
≤ 3xD	1,00	1,00	1,00
≤ 5xD	0,80	0,90	0,90
≤ 6xD	0,70	0,85	0,85
≤ 8xD	0,60	0,75	0,75
≤ 10xD	0,50	0,70	0,70
≤ 12xD	0,45***	0,65	0,65
≤ 15xD	0,40***	0,60	0,60
≤ 20xD	0,35***	0,60	0,60
≤ 25xD	0,35***	0,50	0,50
≤ 30xD	0,30***	0,50	0,50
≤ 35xD	0,30***	0,50	0,50

### Korrekturfaktor Konuswinkel - $k_{KW}$

$\varphi$ [°]	$k_{KW}$		
	$a_p$	n	$v_f$
0	1,00	1,00	1,00
0,5	1,01	1,01	1,01
1	1,02	1,02	1,02
1,5	1,03	1,03	1,03
3	1,06	1,06	1,06

#### Hinweis:

Für die Ermittlung der Schnittwerte bitte die Hinweise auf den Seiten 520-523 beachten.

\* MILLER Zerspanungsgruppen

\*\* Wenn die Legierungsbestandteile Cr, Mo, Ni, V, W in Summe > 8 %, dann die nächst höhere MILLER Zerspanungsgruppe wählen.

\*\*\* Rücksprache mit einem MILLER Anwendungstechniker.



Schichten  
(ebene Bereiche)

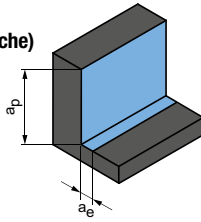

Eintauchwinkel  
0,5° - 1,0°

	a <sub>p</sub> [mm]	a <sub>e</sub> [mm]	v <sub>c</sub> [m/min]	f <sub>z</sub> [mm]																	
				Fräserdurchmesser [mm]																	
				0,10	0,20	0,30	0,40	0,50	0,60	0,80	1,00	1,50	1,80	2,00	2,50	3,00	4,00	5,00	6,00	8,00	10,00
0,012xD	0,65xD	<b>200-250</b>	0,003	0,004	0,006	0,008	0,010	0,011	0,015	0,019	0,027	0,033	0,038	0,048	0,058	0,080	0,102	0,119	0,157	0,190	0,223
0,012xD	0,65xD	<b>190-240</b>	0,003	0,003	0,005	0,007	0,008	0,010	0,013	0,017	0,023	0,029	0,033	0,042	0,051	0,070	0,089	0,105	0,138	0,167	0,196
0,012xD	0,65xD	<b>200-250</b>	0,003	0,004	0,006	0,008	0,010	0,011	0,015	0,019	0,027	0,033	0,038	0,048	0,058	0,080	0,102	0,119	0,157	0,190	0,223
0,012xD	0,65xD	<b>190-240</b>	0,003	0,003	0,005	0,007	0,008	0,010	0,013	0,017	0,023	0,029	0,033	0,042	0,051	0,070	0,089	0,105	0,138	0,167	0,196
0,012xD	0,65xD	<b>200-250</b>	0,003	0,004	0,005	0,007	0,009	0,011	0,014	0,018	0,025	0,032	0,036	0,045	0,055	0,076	0,097	0,113	0,149	0,181	0,212
0,012xD	0,65xD	<b>190-240</b>	0,003	0,003	0,005	0,007	0,008	0,010	0,013	0,017	0,023	0,029	0,033	0,042	0,051	0,070	0,089	0,105	0,138	0,167	0,196
0,012xD	0,65xD	<b>180-230</b>	0,002	0,003	0,004	0,006	0,007	0,008	0,011	0,014	0,019	0,024	0,028	0,035	0,042	0,058	0,074	0,087	0,114	0,139	0,163
0,012xD	0,65xD	<b>180-230</b>	0,003	0,004	0,006	0,008	0,010	0,011	0,015	0,019	0,027	0,033	0,038	0,048	0,058	0,080	0,102	0,119	0,157	0,190	0,223
0,012xD	0,65xD	<b>180-230</b>	0,003	0,003	0,005	0,007	0,008	0,010	0,013	0,017	0,023	0,029	0,033	0,042	0,051	0,070	0,089	0,105	0,138	0,167	0,196
0,012xD	0,65xD	<b>180-230</b>	0,002	0,003	0,004	0,006	0,007	0,008	0,011	0,014	0,019	0,024	0,028	0,035	0,042	0,058	0,074	0,087	0,114	0,139	0,163
0,013xD	0,4xD	<b>90-120</b>	0,003	0,003	0,005	0,007	0,008	0,010	0,013	0,017	0,023	0,029	0,033	0,042	0,051	0,070	0,089	0,105	0,138	0,167	0,196
0,012xD	0,4xD	<b>70-90</b>	0,002	0,003	0,004	0,006	0,007	0,008	0,011	0,014	0,019	0,024	0,028	0,035	0,042	0,058	0,074	0,087	0,114	0,139	0,163
0,013xD	0,4xD	<b>90-120</b>	0,003	0,003	0,005	0,007	0,008	0,010	0,013	0,017	0,023	0,029	0,033	0,042	0,051	0,070	0,089	0,105	0,138	0,167	0,196
0,012xD	0,4xD	<b>70-90</b>	0,002	0,003	0,004	0,006	0,007	0,008	0,011	0,014	0,019	0,024	0,028	0,035	0,042	0,058	0,074	0,087	0,114	0,139	0,163
0,012xD	0,65xD	<b>200-250</b>	0,003	0,004	0,006	0,008	0,010	0,011	0,015	0,019	0,027	0,033	0,038	0,048	0,058	0,080	0,102	0,119	0,157	0,190	0,223
0,012xD	0,65xD	<b>200-250</b>	0,003	0,003	0,005	0,007	0,008	0,010	0,013	0,017	0,023	0,029	0,033	0,042	0,051	0,070	0,089	0,105	0,138	0,167	0,196
0,012xD	0,65xD	<b>200-250</b>	0,003	0,003	0,005	0,007	0,008	0,010	0,013	0,017	0,023	0,029	0,033	0,042	0,051	0,070	0,089	0,105	0,138	0,167	0,196
0,012xD	0,65xD	<b>190-240</b>	0,003	0,003	0,005	0,007	0,008	0,010	0,013	0,017	0,023	0,029	0,033	0,042	0,051	0,070	0,089	0,105	0,138	0,167	0,196
0,012xD	0,65xD	<b>200-250</b>	0,002	0,003	0,004	0,006	0,007	0,008	0,011	0,014	0,019	0,024	0,028	0,035	0,042	0,058	0,074	0,087	0,114	0,139	0,163
0,012xD	0,65xD	<b>190-240</b>	0,002	0,002	0,004	0,005	0,006	0,007	0,009	0,012	0,017	0,021	0,024	0,029	0,036	0,050	0,063	0,074	0,097	0,118	0,139
0,012xD	0,65xD	<b>160-200</b>	0,002	0,003	0,004	0,006	0,007	0,009	0,012	0,014	0,020	0,025	0,029	0,036	0,044	0,061	0,077	0,090	0,119	0,144	0,170
0,01xD	0,65xD	<b>120-160</b>	0,002	0,003	0,004	0,005	0,007	0,008	0,011	0,014	0,019	0,024	0,027	0,034	0,042	0,058	0,073	0,086	0,113	0,137	0,161
0,01xD	0,65xD	<b>80-120</b>	0,001	0,002	0,003	0,004	0,005	0,006	0,008	0,010	0,013	0,017	0,019	0,024	0,029	0,040	0,051	0,060	0,079	0,096	0,113

Die angegebenen Arbeitswerte sind Richtwerte.

Die für den jeweiligen Bearbeitungsfall optimalen Daten sollten im Versuch oder während der Bearbeitung ermittelt werden.

# Schnittwertempfehlung für Eckradiusfräser

Vorschub und Schnittgeschwindigkeit

## OptiMill-3D-CR-Hardened | TCR107, TCR109

MZG*	Werkstoff	Festigkeit/Härte [N/mm <sup>2</sup> ] [HRC]	Kühlung			
			Trocken	Luft/MMS	KSS	
P	P1.1	Bau-, Automaten-, Einsatz- und Vergütungsstähle, unlegiert	< 700	✓	✓	✓
	P1.2	Bau-, Automaten-, Einsatz- und Vergütungsstähle, unlegiert	< 1.200	✓	✓	✓
	P2.1	Nitrier-, Einsatz- und Vergütungsstähle, legiert	< 900	✓	✓	✓
	P2.2	Nitrier-, Einsatz- und Vergütungsstähle, legiert	< 1.400	✓	✓	✓
	P3.1	Werkzeug-, Wälzlager-, Feder- und Schnellarbeitsstähle**	< 800	✓	✓	✓
	P3.2	Werkzeug-, Wälzlager-, Feder- und Schnellarbeitsstähle**	< 1.000	✓	✓	✓
	P3.3	Werkzeug-, Wälzlager-, Feder- und Schnellarbeitsstähle**	< 1.500	✓	✓	✓
	P4.1	Rostfreie Stähle, ferritisch und martensitisch			✓	✓
	P5.1	Stahlguss			✓	✓
	P6.1	Rostfreier Stahlguss, ferritisch und martensitisch			✓	✓
K	K1.1	Gusseisen mit Lamellengraphit (Grauguss), GJL	< 300	✓	✓	✓
	K2.1	Gusseisen mit Kugelgraphit, GJS	< 500	✓	✓	✓
	K2.2	Gusseisen mit Kugelgraphit, GJS	≤ 800	✓	✓	✓
	K2.3	Gusseisen mit Kugelgraphit, GJS	> 800	✓	✓	✓
	K3.1	Gusseisen mit Vermiculargraphit, GJV; Temperguss, GJM	< 500	✓	✓	✓
	K3.2	Gusseisen mit Vermiculargraphit, GJV; Temperguss, GJM	> 500	✓	✓	✓
H	H1.1	Gehärteter Stahl/Stahlguss	< 44 HRC	✓	✓	
	H1.2	Gehärteter Stahl/Stahlguss	< 55 HRC	✓	✓	
	H2.1	Gehärteter Stahl/Stahlguss	< 60 HRC		✓	

### Korrekturfaktor Arbeitstiefe - $k_{AT}$

AT	$k_{AT}$		
	$a_p$	n	$v_f$
≤ 3xD	1,00	1,00	1,00
≤ 5xD	0,80	0,90	0,90
≤ 6xD	0,70	0,85	0,85
≤ 8xD	0,60	0,75	0,75
≤ 10xD	0,50	0,70	0,70
≤ 12xD	0,45***	0,65	0,65
≤ 15xD	0,40***	0,60	0,60
≤ 20xD	0,35***	0,60	0,60
≤ 25xD	0,35***	0,50	0,50
≤ 30xD	0,30***	0,50	0,50
≤ 35xD	0,30***	0,50	0,50

### Korrekturfaktor Konuswinkel - $k_{KW}$

$\varphi$ [°]	$k_{KW}$		
	$a_p$	n	$v_f$
0	1,00	1,00	1,00
0,5	1,01	1,01	1,01
1	1,02	1,02	1,02
1,5	1,03	1,03	1,03
3	1,06	1,06	1,06

#### Hinweis:

Für die Ermittlung der Schnittwerte bitte die Hinweise auf den Seiten 520-523 beachten.

\* MILLER Zerspanungsgruppen

\*\* Wenn die Legierungsbestandteile Cr, Mo, Ni, V, W in Summe > 8 %, dann die nächst höhere MILLER Zerspanungsgruppe wählen.

\*\*\* Rücksprache mit einem MILLER Anwendungstechniker.

Schruppen

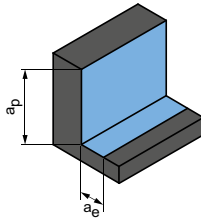

Eintauchwinkel  
1,0° - 3,0°

Nächste Seite:  
**Schichten (3D, Abzeilen)**

a <sub>p</sub> [mm]	a <sub>e</sub> [mm]	v <sub>c</sub> [m/min]	f <sub>z</sub> [mm]																		
			Fräserdurchmesser [mm]																		
			0,10	0,20	0,30	0,40	0,50	0,60	0,80	1,00	1,50	1,80	2,00	2,50	3,00	4,00	5,00	6,00	8,00	10,00	12,00
0,15xD	0,45xD	250-300	0,003	0,004	0,006	0,008	0,010	0,012	0,016	0,020	0,028	0,035	0,040	0,050	0,061	0,084	0,107	0,125	0,165	0,200	0,235
0,15xD	0,45xD	240-280	0,003	0,004	0,005	0,007	0,009	0,011	0,014	0,018	0,025	0,031	0,035	0,044	0,054	0,074	0,094	0,110	0,145	0,176	0,207
0,15xD	0,45xD	250-300	0,003	0,004	0,006	0,008	0,010	0,012	0,016	0,020	0,028	0,035	0,040	0,050	0,061	0,084	0,107	0,125	0,165	0,200	0,235
0,15xD	0,45xD	240-280	0,003	0,004	0,005	0,007	0,009	0,011	0,014	0,018	0,025	0,031	0,035	0,044	0,054	0,074	0,094	0,110	0,145	0,176	0,207
0,15xD	0,45xD	250-300	0,003	0,004	0,006	0,008	0,010	0,011	0,015	0,019	0,027	0,033	0,038	0,048	0,058	0,080	0,102	0,119	0,157	0,190	0,223
0,15xD	0,45xD	240-280	0,003	0,004	0,005	0,007	0,009	0,011	0,014	0,018	0,025	0,031	0,035	0,044	0,054	0,074	0,094	0,110	0,145	0,176	0,207
0,15xD	0,45xD	220-260	0,002	0,003	0,004	0,006	0,007	0,009	0,012	0,015	0,020	0,026	0,029	0,037	0,045	0,061	0,078	0,091	0,120	0,146	0,172
0,15xD	0,45xD	240-280	0,003	0,004	0,006	0,008	0,010	0,012	0,016	0,020	0,028	0,035	0,040	0,050	0,061	0,084	0,107	0,125	0,165	0,200	0,235
0,15xD	0,45xD	240-280	0,003	0,004	0,005	0,007	0,009	0,011	0,014	0,018	0,025	0,031	0,035	0,044	0,054	0,074	0,094	0,110	0,145	0,176	0,207
0,15xD	0,45xD	200-250	0,002	0,003	0,004	0,006	0,007	0,009	0,012	0,015	0,020	0,026	0,029	0,037	0,045	0,061	0,078	0,091	0,120	0,146	0,172
0,15xD	0,55xD	250-300	0,004	0,005	0,007	0,010	0,012	0,014	0,019	0,024	0,034	0,042	0,048	0,060	0,073	0,101	0,128	0,150	0,198	0,240	0,282
0,15xD	0,55xD	250-300	0,003	0,004	0,006	0,008	0,010	0,012	0,016	0,020	0,028	0,035	0,040	0,050	0,061	0,084	0,107	0,125	0,165	0,200	0,235
0,15xD	0,55xD	240-280	0,003	0,004	0,006	0,008	0,010	0,012	0,016	0,020	0,028	0,035	0,040	0,050	0,061	0,084	0,107	0,125	0,165	0,200	0,235
0,15xD	0,55xD	240-280	0,003	0,004	0,005	0,007	0,009	0,011	0,014	0,018	0,025	0,031	0,035	0,044	0,054	0,074	0,094	0,110	0,145	0,176	0,207
0,15xD	0,55xD	250-300	0,002	0,003	0,004	0,006	0,007	0,009	0,012	0,015	0,020	0,026	0,029	0,037	0,045	0,061	0,078	0,091	0,120	0,146	0,172
0,15xD	0,55xD	240-280	0,002	0,002	0,004	0,005	0,006	0,007	0,010	0,012	0,017	0,022	0,025	0,031	0,038	0,052	0,066	0,078	0,102	0,124	0,146
0,06xD	0,35xD	200-250	0,002	0,003	0,004	0,006	0,007	0,009	0,012	0,015	0,020	0,026	0,029	0,037	0,045	0,061	0,078	0,091	0,120	0,146	0,172
0,05xD	0,3xD	180-230	0,002	0,002	0,004	0,005	0,006	0,007	0,010	0,012	0,017	0,021	0,024	0,030	0,037	0,050	0,064	0,075	0,099	0,120	0,141
0,025xD	0,25xD	140-180	0,001	0,002	0,002	0,003	0,004	0,005	0,006	0,008	0,011	0,014	0,016	0,020	0,024	0,034	0,043	0,050	0,066	0,080	0,094

Die angegebenen Arbeitswerte sind Richtwerte.  
Die für den jeweiligen Bearbeitungsfall optimalen Daten sollten im Versuch oder während der Bearbeitung ermittelt werden.

# Schnittwertempfehlung für Eckradiusfräser

Vorschub und Schnittgeschwindigkeit

## OptiMill-3D-CR-Hardened | TCR107, TCR109

MZG*	Werkstoff	Festigkeit/Härte [N/mm <sup>2</sup> ] [HRC]	Kühlung			
			Trocken	Luft/MMS	KSS	
P	P1.1	Bau-, Automaten-, Einsatz- und Vergütungsstähle, unlegiert	< 700	✓	✓	✓
	P1.2	Bau-, Automaten-, Einsatz- und Vergütungsstähle, unlegiert	< 1.200	✓	✓	✓
	P2.1	Nitrier-, Einsatz- und Vergütungsstähle, legiert	< 900	✓	✓	✓
	P2.2	Nitrier-, Einsatz- und Vergütungsstähle, legiert	< 1.400	✓	✓	✓
	P3.1	Werkzeug-, Wälzlager-, Feder- und Schnellarbeitsstähle**	< 800	✓	✓	✓
	P3.2	Werkzeug-, Wälzlager-, Feder- und Schnellarbeitsstähle**	< 1.000	✓	✓	✓
	P3.3	Werkzeug-, Wälzlager-, Feder- und Schnellarbeitsstähle**	< 1.500	✓	✓	✓
	P4.1	Rostfreie Stähle, ferritisch und martensitisch			✓	✓
	P5.1	Stahlguss			✓	✓
	P6.1	Rostfreier Stahlguss, ferritisch und martensitisch			✓	✓
K	K1.1	Gusseisen mit Lamellengraphit (Grauguss), GJL	< 300	✓	✓	✓
	K2.1	Gusseisen mit Kugelgraphit, GJS	< 500	✓	✓	✓
	K2.2	Gusseisen mit Kugelgraphit, GJS	≤ 800	✓	✓	✓
	K2.3	Gusseisen mit Kugelgraphit, GJS	> 800	✓	✓	✓
	K3.1	Gusseisen mit Vermiculargraphit, GJV; Temperguss, GJM	< 500	✓	✓	✓
	K3.2	Gusseisen mit Vermiculargraphit, GJV; Temperguss, GJM	> 500	✓	✓	✓
H	H1.1	Gehärteter Stahl/Stahlguss	< 44 HRC	✓	✓	
	H1.2	Gehärteter Stahl/Stahlguss	< 55 HRC	✓	✓	
	H2.1	Gehärteter Stahl/Stahlguss	< 60 HRC		✓	
	H2.2	Gehärteter Stahl/Stahlguss	< 65 HRC		✓	
	H2.3	Gehärteter Stahl/Stahlguss	< 68 HRC		✓	
	H3.1	Verschleißbeständiger Guss/Hartguss, GJN		✓	✓	

### Korrekturfaktor Arbeitstiefe - $k_{AT}$

AT	$k_{AT}$		
	$a_p$	n	$v_f$
≤ 3xD	1,00	1,00	1,00
≤ 5xD	0,80	0,90	0,90
≤ 6xD	0,70	0,85	0,85
≤ 8xD	0,60	0,75	0,75
≤ 10xD	0,50	0,70	0,70
≤ 12xD	0,45***	0,65	0,65
≤ 15xD	0,40***	0,60	0,60
≤ 20xD	0,35***	0,60	0,60
≤ 25xD	0,35***	0,50	0,50
≤ 30xD	0,30***	0,50	0,50
≤ 35xD	0,30***	0,50	0,50

### Korrekturfaktor Konuswinkel - $k_{KW}$

$\varphi$ [°]	$k_{KW}$		
	$a_p$	n	$v_f$
0	1,00	1,00	1,00
0,5	1,01	1,01	1,01
1	1,02	1,02	1,02
1,5	1,03	1,03	1,03
3	1,06	1,06	1,06

#### Hinweis:

Für die Ermittlung der Schnittwerte bitte die Hinweise auf den Seiten 520-523 beachten.

\* MILLER Zerspanungsgruppen

\*\* Wenn die Legierungsbestandteile Cr, Mo, Ni, V, W in Summe > 8 %, dann die nächst höhere MILLER Zerspanungsgruppe wählen.

\*\*\* Rücksprache mit einem MILLER Anwendungstechniker.

Schichten  
(3D, Abzeilen)

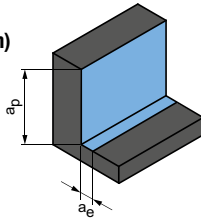

Nächste Seite:  
Schichten (ebene Bereiche)

ap [mm]	ae [mm]	vc [m/min]	fz [mm]																		
			Fräserdurchmesser [mm]																		
			0,10	0,20	0,30	0,40	0,50	0,60	0,80	1,00	1,50	1,80	2,00	2,50	3,00	4,00	5,00	6,00	8,00	10,00	12,00
0,012xD	0,022xD	<b>280-340</b>	0,003	0,004	0,006	0,008	0,010	0,011	0,015	0,019	0,027	0,033	0,038	0,048	0,058	0,080	0,102	0,119	0,157	0,190	0,223
0,012xD	0,022xD	<b>280-320</b>	0,003	0,003	0,005	0,007	0,008	0,010	0,013	0,017	0,023	0,029	0,033	0,042	0,051	0,070	0,089	0,105	0,138	0,167	0,196
0,012xD	0,022xD	<b>270-320</b>	0,003	0,004	0,006	0,008	0,010	0,011	0,015	0,019	0,027	0,033	0,038	0,048	0,058	0,080	0,102	0,119	0,157	0,190	0,223
0,012xD	0,022xD	<b>260-300</b>	0,003	0,003	0,005	0,007	0,008	0,010	0,013	0,017	0,023	0,029	0,033	0,042	0,051	0,070	0,089	0,105	0,138	0,167	0,196
0,012xD	0,022xD	<b>280-320</b>	0,003	0,004	0,005	0,007	0,009	0,011	0,014	0,018	0,025	0,032	0,036	0,045	0,055	0,076	0,097	0,113	0,149	0,181	0,212
0,012xD	0,022xD	<b>260-300</b>	0,003	0,003	0,005	0,007	0,008	0,010	0,013	0,017	0,023	0,029	0,033	0,042	0,051	0,070	0,089	0,105	0,138	0,167	0,196
0,012xD	0,022xD	<b>240-280</b>	0,002	0,003	0,004	0,006	0,007	0,008	0,011	0,014	0,019	0,024	0,028	0,035	0,042	0,058	0,074	0,087	0,114	0,139	0,163
0,012xD	0,022xD	<b>260-300</b>	0,003	0,004	0,006	0,008	0,010	0,011	0,015	0,019	0,027	0,033	0,038	0,048	0,058	0,080	0,102	0,119	0,157	0,190	0,223
0,012xD	0,022xD	<b>260-300</b>	0,003	0,003	0,005	0,007	0,008	0,010	0,013	0,017	0,023	0,029	0,033	0,042	0,051	0,070	0,089	0,105	0,138	0,167	0,196
0,012xD	0,022xD	<b>220-270</b>	0,002	0,003	0,004	0,006	0,007	0,008	0,011	0,014	0,019	0,024	0,028	0,035	0,042	0,058	0,074	0,087	0,114	0,139	0,163
0,012xD	0,022xD	<b>280-340</b>	0,003	0,004	0,006	0,008	0,010	0,011	0,015	0,019	0,027	0,033	0,038	0,048	0,058	0,080	0,102	0,119	0,157	0,190	0,223
0,012xD	0,022xD	<b>280-320</b>	0,003	0,003	0,005	0,007	0,008	0,010	0,013	0,017	0,023	0,029	0,033	0,042	0,051	0,070	0,089	0,105	0,138	0,167	0,196
0,012xD	0,022xD	<b>270-320</b>	0,003	0,003	0,005	0,007	0,008	0,010	0,013	0,017	0,023	0,029	0,033	0,042	0,051	0,070	0,089	0,105	0,138	0,167	0,196
0,012xD	0,022xD	<b>260-300</b>	0,003	0,003	0,005	0,007	0,008	0,010	0,013	0,017	0,023	0,029	0,033	0,042	0,051	0,070	0,089	0,105	0,138	0,167	0,196
0,012xD	0,022xD	<b>280-320</b>	0,002	0,003	0,004	0,006	0,007	0,008	0,011	0,014	0,019	0,024	0,028	0,035	0,042	0,058	0,074	0,087	0,114	0,139	0,163
0,012xD	0,022xD	<b>260-300</b>	0,002	0,002	0,004	0,005	0,006	0,007	0,009	0,012	0,017	0,021	0,024	0,029	0,036	0,050	0,063	0,074	0,097	0,118	0,139
0,012xD	0,022xD	<b>220-250</b>	0,002	0,003	0,004	0,006	0,007	0,009	0,012	0,014	0,020	0,025	0,029	0,036	0,044	0,061	0,077	0,090	0,119	0,144	0,170
0,01xD	0,02xD	<b>190-220</b>	0,002	0,003	0,004	0,005	0,007	0,008	0,011	0,014	0,019	0,024	0,027	0,034	0,042	0,058	0,073	0,086	0,113	0,137	0,161
0,01xD	0,02xD	<b>150-190</b>	0,001	0,002	0,003	0,004	0,005	0,006	0,008	0,010	0,013	0,017	0,019	0,024	0,029	0,040	0,051	0,060	0,079	0,096	0,113
0,007xD	0,017xD	<b>120-150</b>	0,001	0,002	0,003	0,003	0,004	0,005	0,007	0,008	0,012	0,015	0,017	0,021	0,025	0,035	0,045	0,052	0,069	0,084	0,098
0,005xD	0,015xD	<b>80-120</b>	0,001	0,002	0,002	0,003	0,004	0,005	0,006	0,008	0,011	0,014	0,016	0,020	0,024	0,033	0,042	0,050	0,065	0,079	0,093
0,008xD	0,018xD	<b>150-200</b>	0,001	0,002	0,003	0,004	0,005	0,006	0,008	0,010	0,013	0,017	0,019	0,024	0,029	0,040	0,051	0,060	0,079	0,096	0,113

Die angegebenen Arbeitswerte sind Richtwerte.

Die für den jeweiligen Bearbeitungsfall optimalen Daten sollten im Versuch oder während der Bearbeitung ermittelt werden.

# Schnittwertempfehlung für Eckradiusfräser

Vorschub und Schnittgeschwindigkeit

## OptiMill-3D-CR-Hardened | TCR107, TCR109

MZG*	Werkstoff	Festigkeit/Härte [N/mm <sup>2</sup> ] [HRC]	Kühlung			
			Trocken	Luft/MMS	KSS	
P	P1.1	Bau-, Automaten-, Einsatz- und Vergütungsstähle, unlegiert	< 700	✓	✓	✓
	P1.2	Bau-, Automaten-, Einsatz- und Vergütungsstähle, unlegiert	< 1.200	✓	✓	✓
	P2.1	Nitrier-, Einsatz- und Vergütungsstähle, legiert	< 900	✓	✓	✓
	P2.2	Nitrier-, Einsatz- und Vergütungsstähle, legiert	< 1.400	✓	✓	✓
	P3.1	Werkzeug-, Wälzlager-, Feder- und Schnellarbeitsstähle**	< 800	✓	✓	✓
	P3.2	Werkzeug-, Wälzlager-, Feder- und Schnellarbeitsstähle**	< 1.000	✓	✓	✓
	P3.3	Werkzeug-, Wälzlager-, Feder- und Schnellarbeitsstähle**	< 1.500	✓	✓	✓
	P4.1	Rostfreie Stähle, ferritisch und martensitisch			✓	✓
	P5.1	Stahlguss			✓	✓
	P6.1	Rostfreier Stahlguss, ferritisch und martensitisch			✓	✓
K	K1.1	Gusseisen mit Lamellengraphit (Grauguss), GJL	< 300	✓	✓	✓
	K2.1	Gusseisen mit Kugelgraphit, GJS	< 500	✓	✓	✓
	K2.2	Gusseisen mit Kugelgraphit, GJS	≤ 800	✓	✓	✓
	K2.3	Gusseisen mit Kugelgraphit, GJS	> 800	✓	✓	✓
	K3.1	Gusseisen mit Vermiculargraphit, GJV; Temperguss, GJM	< 500	✓	✓	✓
	K3.2	Gusseisen mit Vermiculargraphit, GJV; Temperguss, GJM	> 500	✓	✓	✓
H	H1.1	Gehärteter Stahl/Stahlguss	< 44 HRC	✓	✓	
	H1.2	Gehärteter Stahl/Stahlguss	< 55 HRC	✓	✓	
	H2.1	Gehärteter Stahl/Stahlguss	< 60 HRC		✓	
	H2.2	Gehärteter Stahl/Stahlguss	< 65 HRC		✓	
	H2.3	Gehärteter Stahl/Stahlguss	< 68 HRC		✓	
	H3.1	Verschleißbeständiger Guss/Hartguss, GJN		✓	✓	

### Korrekturfaktor Arbeitstiefe - $k_{AT}$

AT	$k_{AT}$		
	$a_p$	n	$v_f$
≤ 3xD	1,00	1,00	1,00
≤ 5xD	0,80	0,90	0,90
≤ 6xD	0,70	0,85	0,85
≤ 8xD	0,60	0,75	0,75
≤ 10xD	0,50	0,70	0,70
≤ 12xD	0,45***	0,65	0,65
≤ 15xD	0,40***	0,60	0,60
≤ 20xD	0,35***	0,60	0,60
≤ 25xD	0,35***	0,50	0,50
≤ 30xD	0,30***	0,50	0,50
≤ 35xD	0,30***	0,50	0,50

### Korrekturfaktor Konuswinkel - $k_{KW}$

$\varphi$ [°]	$k_{KW}$		
	$a_p$	n	$v_f$
0	1,00	1,00	1,00
0,5	1,01	1,01	1,01
1	1,02	1,02	1,02
1,5	1,03	1,03	1,03
3	1,06	1,06	1,06

#### Hinweis:

Für die Ermittlung der Schnittwerte bitte die Hinweise auf den Seiten 520-523 beachten.

\* MILLER Zerspanungsgruppen

\*\* Wenn die Legierungsbestandteile Cr, Mo, Ni, V, W in Summe > 8 %, dann die nächst höhere MILLER Zerspanungsgruppe wählen.

\*\*\* Rücksprache mit einem MILLER Anwendungstechniker.

Schichten  
(ebene Bereiche)

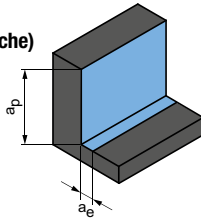

Eintauchwinkel  
0,5° - 1,0°

a <sub>p</sub> [mm]	a <sub>e</sub> [mm]	v <sub>c</sub> [m/min]	f <sub>z</sub> [mm]																		
			Fräserdurchmesser [mm]																		
			0,10	0,20	0,30	0,40	0,50	0,60	0,80	1,00	1,50	1,80	2,00	2,50	3,00	4,00	5,00	6,00	8,00	10,00	12,00
0,012xD	0,65xD	<b>200-250</b>	0,003	0,004	0,006	0,008	0,010	0,011	0,015	0,019	0,027	0,033	0,038	0,048	0,058	0,080	0,102	0,119	0,157	0,190	0,223
0,012xD	0,65xD	<b>190-240</b>	0,003	0,003	0,005	0,007	0,008	0,010	0,013	0,017	0,023	0,029	0,033	0,042	0,051	0,070	0,089	0,105	0,138	0,167	0,196
0,012xD	0,65xD	<b>200-250</b>	0,003	0,004	0,006	0,008	0,010	0,011	0,015	0,019	0,027	0,033	0,038	0,048	0,058	0,080	0,102	0,119	0,157	0,190	0,223
0,012xD	0,65xD	<b>190-240</b>	0,003	0,003	0,005	0,007	0,008	0,010	0,013	0,017	0,023	0,029	0,033	0,042	0,051	0,070	0,089	0,105	0,138	0,167	0,196
0,012xD	0,65xD	<b>200-250</b>	0,003	0,004	0,005	0,007	0,009	0,011	0,014	0,018	0,025	0,032	0,036	0,045	0,055	0,076	0,097	0,113	0,149	0,181	0,212
0,012xD	0,65xD	<b>190-240</b>	0,003	0,003	0,005	0,007	0,008	0,010	0,013	0,017	0,023	0,029	0,033	0,042	0,051	0,070	0,089	0,105	0,138	0,167	0,196
0,012xD	0,65xD	<b>180-230</b>	0,002	0,003	0,004	0,006	0,007	0,008	0,011	0,014	0,019	0,024	0,028	0,035	0,042	0,058	0,074	0,087	0,114	0,139	0,163
0,012xD	0,65xD	<b>180-230</b>	0,003	0,004	0,006	0,008	0,010	0,011	0,015	0,019	0,027	0,033	0,038	0,048	0,058	0,080	0,102	0,119	0,157	0,190	0,223
0,012xD	0,65xD	<b>180-230</b>	0,003	0,003	0,005	0,007	0,008	0,010	0,013	0,017	0,023	0,029	0,033	0,042	0,051	0,070	0,089	0,105	0,138	0,167	0,196
0,012xD	0,65xD	<b>180-230</b>	0,002	0,003	0,004	0,006	0,007	0,008	0,011	0,014	0,019	0,024	0,028	0,035	0,042	0,058	0,074	0,087	0,114	0,139	0,163
0,012xD	0,65xD	<b>200-250</b>	0,003	0,004	0,006	0,008	0,010	0,011	0,015	0,019	0,027	0,033	0,038	0,048	0,058	0,080	0,102	0,119	0,157	0,190	0,223
0,012xD	0,65xD	<b>200-250</b>	0,003	0,003	0,005	0,007	0,008	0,010	0,013	0,017	0,023	0,029	0,033	0,042	0,051	0,070	0,089	0,105	0,138	0,167	0,196
0,012xD	0,65xD	<b>200-250</b>	0,003	0,003	0,005	0,007	0,008	0,010	0,013	0,017	0,023	0,029	0,033	0,042	0,051	0,070	0,089	0,105	0,138	0,167	0,196
0,012xD	0,65xD	<b>190-240</b>	0,003	0,003	0,005	0,007	0,008	0,010	0,013	0,017	0,023	0,029	0,033	0,042	0,051	0,070	0,089	0,105	0,138	0,167	0,196
0,012xD	0,65xD	<b>200-250</b>	0,002	0,003	0,004	0,006	0,007	0,008	0,011	0,014	0,019	0,024	0,028	0,035	0,042	0,058	0,074	0,087	0,114	0,139	0,163
0,012xD	0,65xD	<b>190-240</b>	0,002	0,002	0,004	0,005	0,006	0,007	0,009	0,012	0,017	0,021	0,024	0,029	0,036	0,050	0,063	0,074	0,097	0,118	0,139
0,012xD	0,65xD	<b>160-200</b>	0,002	0,003	0,004	0,006	0,007	0,009	0,012	0,014	0,020	0,025	0,029	0,036	0,044	0,061	0,077	0,090	0,119	0,144	0,170
0,01xD	0,65xD	<b>120-160</b>	0,002	0,003	0,004	0,005	0,007	0,008	0,011	0,014	0,019	0,024	0,027	0,034	0,042	0,058	0,073	0,086	0,113	0,137	0,161
0,01xD	0,65xD	<b>80-120</b>	0,001	0,002	0,003	0,004	0,005	0,006	0,008	0,010	0,013	0,017	0,019	0,024	0,029	0,040	0,051	0,060	0,079	0,096	0,113
0,006xD	0,45xD	<b>50-80</b>	0,001	0,002	0,003	0,003	0,004	0,005	0,007	0,008	0,012	0,015	0,017	0,021	0,025	0,035	0,045	0,052	0,069	0,084	0,098
0,005xD	0,3xD	<b>35-60</b>	0,001	0,002	0,002	0,003	0,004	0,005	0,006	0,008	0,011	0,014	0,016	0,020	0,024	0,033	0,042	0,050	0,065	0,079	0,093
0,008xD	0,55xD	<b>80-120</b>	0,001	0,002	0,003	0,004	0,005	0,006	0,008	0,010	0,013	0,017	0,019	0,024	0,029	0,040	0,051	0,060	0,079	0,096	0,113

Die angegebenen Arbeitswerte sind Richtwerte.

Die für den jeweiligen Bearbeitungsfall optimalen Daten sollten im Versuch oder während der Bearbeitung ermittelt werden.

# Schnittwertempfehlung für Eckradiusfräser

Vorschub und Schnittgeschwindigkeit

## OptiMill-3D-CR-Alu | TCR120

MZG*	Werkstoff	Festigkeit/Härte [N/mm <sup>2</sup> ] [HRC]	Kühlung		
			Trocken	Luft/MMS	KSS
N1	N1.1 Aluminium, unlegiert und legiert <3 % Si				✓
	N1.2 Aluminium, legiert ≤ 7 % Si				✓
	N1.3 Aluminium, legiert > 7-12 % Si				✓
	N1.4 Aluminium, legiert > 12 % Si				✓
N2	N2.1 Kupfer, unlegiert und niedriglegiert	< 300			✓
	N2.2 Kupfer, legiert	> 300			✓
	N2.3 Messing, Bronze, Rotguss	< 1.200	✓	✓	✓



## Schruppen

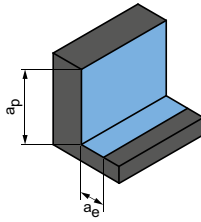

Eintauchwinkel  
1,0° - 3,0°

Nächste Seite:  
**Schlichten (3D, Abzeilen)**

$a_p$ [mm]	$a_e$ [mm]	$v_c$ [m/min]	$f_z$ [mm]									
			Fräserdurchmesser [mm]									
			2,00	3,00	4,00	5,00	6,00	8,00	10,00	12,00	16,00	20,00
0,15xD	0,6xD	<b>400-600</b>	0,038	0,057	0,062	0,082	0,090	0,102	0,120	0,155	0,180	0,205
0,15xD	0,6xD	<b>380-580</b>	0,042	0,063	0,068	0,090	0,099	0,112	0,132	0,171	0,198	0,226
0,15xD	0,6xD	<b>340-540</b>	0,046	0,068	0,074	0,098	0,108	0,122	0,144	0,186	0,216	0,246
0,15xD	0,6xD	<b>300-500</b>	0,049	0,074	0,081	0,107	0,117	0,133	0,156	0,202	0,234	0,267
0,15xD	0,6xD	<b>400-500</b>	0,038	0,057	0,062	0,082	0,090	0,102	0,120	0,155	0,180	0,205
0,15xD	0,6xD	<b>300-400</b>	0,038	0,057	0,062	0,082	0,090	0,102	0,120	0,155	0,180	0,205
0,15xD	0,6xD	<b>400-500</b>	0,046	0,068	0,074	0,098	0,108	0,122	0,144	0,186	0,216	0,246

Die angegebenen Arbeitswerte sind Richtwerte.

Die für den jeweiligen Bearbeitungsfall optimalen Daten sollten im Versuch oder während der Bearbeitung ermittelt werden.

# Schnittwertempfehlung für Eckradiusfräser

Vorschub und Schnittgeschwindigkeit

## OptiMill-3D-CR-Alu | TCR120

MZG*	Werkstoff	Festigkeit/Härte [N/mm <sup>2</sup> ] [HRC]	Kühlung		
			Trocken	Luft/MMS	KSS
N	N1	N1.1 Aluminium, unlegiert und legiert <3 % Si			✓
		N1.2 Aluminium, legiert ≤ 7 % Si			✓
		N1.3 Aluminium, legiert > 7-12 % Si			✓
		N1.4 Aluminium, legiert > 12 % Si			✓
N	N2	N2.1 Kupfer, unlegiert und niedriglegiert	< 300		✓
		N2.2 Kupfer, legiert	> 300		✓
		N2.3 Messing, Bronze, Rotguss	< 1.200	✓	✓

## OptiMill-3D-CR-Alu | TCR120

MZG*	Werkstoff	Festigkeit/Härte [N/mm <sup>2</sup> ] [HRC]	Kühlung		
			Trocken	Luft/MMS	KSS
N	N1	N1.1 Aluminium, unlegiert und legiert <3 % Si			✓
		N1.2 Aluminium, legiert ≤ 7 % Si			✓
		N1.3 Aluminium, legiert > 7-12 % Si			✓
		N1.4 Aluminium, legiert > 12 % Si			✓
N	N2	N2.1 Kupfer, unlegiert und niedriglegiert	< 300		✓
		N2.2 Kupfer, legiert	> 300		✓
		N2.3 Messing, Bronze, Rotguss	< 1.200	✓	✓

### Korrekturfaktor Arbeitstiefe - $k_{AT}$

AT	$k_{AT}$		
	$a_p$	$n$	$v_f$
≤ 3xD	1,00	1,00	1,00
≤ 5xD	0,80	0,90	0,90
≤ 6xD	0,70	0,85	0,85
≤ 8xD	0,60	0,75	0,75
≤ 10xD	0,50	0,70	0,70
≤ 12xD	0,45**	0,65	0,65
≤ 15xD	0,40**	0,60	0,60
≤ 20xD	0,35**	0,60	0,60
≤ 25xD	0,35**	0,50	0,50
≤ 30xD	0,30**	0,50	0,50
≤ 35xD	0,30**	0,50	0,50

### Korrekturfaktor Konuswinkel - $k_{KW}$

$\varphi$ [°]	$k_{KW}$		
	$a_p$	$n$	$v_f$
0	1,00	1,00	1,00
0,5	1,01	1,01	1,01
1	1,02	1,02	1,02
1,5	1,03	1,03	1,03
3	1,06	1,06	1,06

#### Hinweis:

Für die Ermittlung der Schnittwerte bitte die Hinweise auf den Seiten 520-523 beachten.

\* MILLER Zerspanungsgruppen

\*\* Rücksprache mit einem MILLER Anwendungstechniker.

**Schichten  
(3D, Abzeilen)**

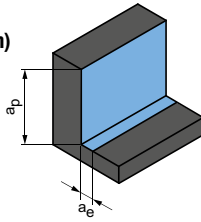

$a_p$ [mm]	$a_e$ [mm]	$v_c$ [m/min]	$f_z$ [mm]										
			Fräserdurchmesser [mm]										
			2,00	3,00	4,00	5,00	6,00	8,00	10,00	12,00	16,00	20,00	
0,015xD	0,025xD	<b>400-600</b>	0,038	0,057	0,062	0,082	0,090	0,102	0,120	0,155	0,180	0,205	
0,015xD	0,025xD	<b>380-580</b>	0,042	0,063	0,068	0,090	0,099	0,112	0,132	0,171	0,198	0,226	
0,015xD	0,025xD	<b>340-540</b>	0,046	0,068	0,074	0,098	0,108	0,122	0,144	0,186	0,216	0,246	
0,015xD	0,025xD	<b>300-500</b>	0,049	0,074	0,081	0,107	0,117	0,133	0,156	0,202	0,234	0,267	
0,015xD	0,025xD	<b>400-500</b>	0,038	0,057	0,062	0,082	0,090	0,102	0,120	0,155	0,180	0,205	
0,015xD	0,025xD	<b>300-400</b>	0,038	0,057	0,062	0,082	0,090	0,102	0,120	0,155	0,180	0,205	
0,015xD	0,025xD	<b>400-500</b>	0,046	0,068	0,074	0,098	0,108	0,122	0,144	0,186	0,216	0,246	

**Schichten  
(ebene Bereiche)**

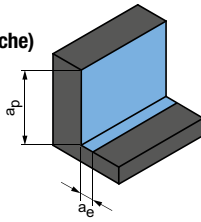

Eintauchwinkel  
0,5° - 1,0°

Nächste Tabelle:  
**Schichten (ebene Bereiche)**

$a_p$ [mm]	$a_e$ [mm]	$v_c$ [m/min]	$f_z$ [mm]										
			Fräserdurchmesser [mm]										
			2,00	3,00	4,00	5,00	6,00	8,00	10,00	12,00	16,00	20,00	
0,015xD	0,6xD	<b>400-600</b>	0,038	0,057	0,062	0,082	0,090	0,102	0,120	0,155	0,180	0,205	
0,015xD	0,6xD	<b>380-580</b>	0,042	0,063	0,068	0,090	0,099	0,112	0,132	0,171	0,198	0,226	
0,015xD	0,6xD	<b>340-540</b>	0,046	0,068	0,074	0,098	0,108	0,122	0,144	0,186	0,216	0,246	
0,015xD	0,6xD	<b>300-500</b>	0,049	0,074	0,081	0,107	0,117	0,133	0,156	0,202	0,234	0,267	
0,015xD	0,6xD	<b>400-500</b>	0,038	0,057	0,062	0,082	0,090	0,102	0,120	0,155	0,180	0,205	
0,015xD	0,6xD	<b>300-400</b>	0,038	0,057	0,062	0,082	0,090	0,102	0,120	0,155	0,180	0,205	
0,015xD	0,6xD	<b>400-500</b>	0,046	0,068	0,074	0,098	0,108	0,122	0,144	0,186	0,216	0,246	

Die angegebenen Arbeitswerte sind Richtwerte.  
Die für den jeweiligen Bearbeitungsfall optimalen Daten sollten im Versuch oder während der Bearbeitung ermittelt werden.

# Schnittwertempfehlung für Kugelfräser

Vorschub und Schnittgeschwindigkeit

## OptiMill-3D-BN | TBN101, TBN104

MZG*	Werkstoff	Festigkeit/Härte [N/mm <sup>2</sup> ] [HRC]	Kühlung			
			Trocken	Luft/MMS	KSS	
P	P1.1	Bau-, Automaten-, Einsatz- und Vergütungsstähle, unlegiert	< 700	✓	✓	✓
	P1.2	Bau-, Automaten-, Einsatz- und Vergütungsstähle, unlegiert	< 1.200	✓	✓	✓
	P2.1	Nitrier-, Einsatz- und Vergütungsstähle, legiert	< 900	✓	✓	✓
	P2.2	Nitrier-, Einsatz- und Vergütungsstähle, legiert	< 1.400	✓	✓	✓
	P3.1	Werkzeug-, Wälzlager-, Feder- und Schnellarbeitsstähle**	< 800	✓	✓	✓
	P3.2	Werkzeug-, Wälzlager-, Feder- und Schnellarbeitsstähle**	< 1.000	✓	✓	✓
	P3.3	Werkzeug-, Wälzlager-, Feder- und Schnellarbeitsstähle**	< 1.500	✓	✓	✓
	P4.1	Rostfreie Stähle, ferritisch und martensitisch			✓	✓
	P5.1	Stahlguss			✓	✓
	P6.1	Rostfreier Stahlguss, ferritisch und martensitisch			✓	✓
M	M1.1	Rostfreie Stähle, austenitisch	< 700			✓
	M1.2	Rostfreie Stähle, ferritisch/austenitisch (Duplex)	< 1.000			✓
	M2.1	Rostfreier Stahlguss, austenitisch	< 700			✓
	M3.1	Rostfreier Stahlguss, ferritisch/austenitisch (Duplex)	< 1.000			✓
K	K1.1	Gusseisen mit Lamellengraphit (Grauguss), GJL	< 300	✓	✓	✓
	K2.1	Gusseisen mit Kugelgraphit, GJS	< 500	✓	✓	✓
	K2.2	Gusseisen mit Kugelgraphit, GJS	≤ 800	✓	✓	✓
	K2.3	Gusseisen mit Kugelgraphit, GJS	> 800	✓	✓	✓
	K3.1	Gusseisen mit Vermiculargraphit, GJV; Temperguss, GJM	< 500	✓	✓	✓
	K3.2	Gusseisen mit Vermiculargraphit, GJV; Temperguss, GJM	> 500	✓	✓	✓
H	H1.1	Gehärteter Stahl/Stahlguss	< 44 HRC	✓	✓	
	H1.2	Gehärteter Stahl/Stahlguss	< 55 HRC	✓	✓	
	H2.1	Gehärteter Stahl/Stahlguss	< 60 HRC		✓	

### Korrekturfaktor Arbeitstiefe - $k_{AT}$

AT	$k_{AT}$		
	$a_p$	n	$v_f$
≤ 3xD	1,00	1,00	1,00
≤ 5xD	0,80	0,90	0,90
≤ 6xD	0,70	0,85	0,85
≤ 8xD	0,60	0,75	0,75
≤ 10xD	0,50	0,70	0,70
≤ 12xD	0,45***	0,65	0,65
≤ 15xD	0,40***	0,60	0,60
≤ 20xD	0,35***	0,60	0,60
≤ 25xD	0,35***	0,50	0,50
≤ 30xD	0,30***	0,50	0,50
≤ 35xD	0,30***	0,50	0,50

### Korrekturfaktor Konuswinkel - $k_{KW}$

$\varphi$ [°]	$k_{KW}$		
	$a_p$	n	$v_f$
0	1,00	1,00	1,00
0,5	1,01	1,01	1,01
1	1,02	1,02	1,02
1,5	1,03	1,03	1,03
3	1,06	1,06	1,06

#### Hinweis:

Für die Ermittlung der Schnittwerte bitte die Hinweise auf den Seiten 520-523 beachten.

\* MILLER Zerspanungsgruppen

\*\* Wenn die Legierungsbestandteile Cr, Mo, Ni, V, W in Summe > 8 %, dann die nächst höhere MILLER Zerspanungsgruppe wählen.

\*\*\* Rücksprache mit einem MILLER Anwendungstechniker.

Schruppen

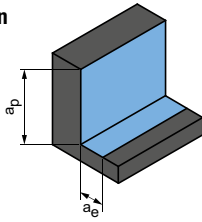

Eintauchwinkel  
1,0° - 3,0°

Nächste Seite:  
**Schlichten**

a <sub>p</sub> [mm]	a <sub>e</sub> [mm]	v <sub>c</sub> [m/min]	f <sub>z</sub> [mm]																			
			Fräserdurchmesser [mm]																			
			0,10	0,20	0,30	0,40	0,50	0,60	0,80	1,00	1,50	1,80	2,00	2,50	3,00	4,00	5,00	6,00	8,00	10,00	12,00	16,00
0,05xD	< 0,25xD	<b>250-300</b>	0,003	0,004	0,006	0,008	0,010	0,012	0,016	0,020	0,028	0,035	0,040	0,050	0,061	0,084	0,107	0,125	0,165	0,200	0,235	0,300
0,045xD	< 0,25xD	<b>240-280</b>	0,003	0,004	0,005	0,007	0,009	0,011	0,014	0,018	0,025	0,031	0,035	0,044	0,054	0,074	0,094	0,110	0,145	0,176	0,207	0,264
0,05xD	< 0,25xD	<b>250-300</b>	0,003	0,004	0,006	0,008	0,010	0,012	0,016	0,020	0,028	0,035	0,040	0,050	0,061	0,084	0,107	0,125	0,165	0,200	0,235	0,300
0,045xD	< 0,25xD	<b>240-280</b>	0,003	0,004	0,005	0,007	0,009	0,011	0,014	0,018	0,025	0,031	0,035	0,044	0,054	0,074	0,094	0,110	0,145	0,176	0,207	0,264
0,05xD	< 0,25xD	<b>250-300</b>	0,003	0,004	0,006	0,008	0,010	0,011	0,015	0,019	0,027	0,033	0,038	0,048	0,058	0,080	0,102	0,119	0,157	0,190	0,223	0,285
0,045xD	< 0,2xD	<b>240-280</b>	0,003	0,004	0,005	0,007	0,009	0,011	0,014	0,018	0,025	0,031	0,035	0,044	0,054	0,074	0,094	0,110	0,145	0,176	0,207	0,264
0,04xD	< 0,2xD	<b>220-260</b>	0,002	0,003	0,004	0,006	0,007	0,009	0,012	0,015	0,020	0,026	0,029	0,037	0,045	0,061	0,078	0,091	0,120	0,146	0,172	0,219
0,05xD	< 0,25xD	<b>240-280</b>	0,003	0,004	0,006	0,008	0,010	0,012	0,016	0,020	0,028	0,035	0,040	0,050	0,061	0,084	0,107	0,125	0,165	0,200	0,235	0,300
0,05xD	< 0,25xD	<b>240-280</b>	0,003	0,004	0,005	0,007	0,009	0,011	0,014	0,018	0,025	0,031	0,035	0,044	0,054	0,074	0,094	0,110	0,145	0,176	0,207	0,264
0,045xD	< 0,25xD	<b>200-250</b>	0,002	0,003	0,004	0,006	0,007	0,009	0,012	0,015	0,020	0,026	0,029	0,037	0,045	0,061	0,078	0,091	0,120	0,146	0,172	0,219
0,05xD	< 0,25xD	<b>85-110</b>	0,003	0,004	0,005	0,007	0,009	0,011	0,014	0,018	0,025	0,031	0,035	0,044	0,054	0,074	0,094	0,110	0,145	0,176	0,207	0,264
0,05xD	< 0,25xD	<b>60-85</b>	0,002	0,003	0,004	0,006	0,007	0,009	0,012	0,015	0,020	0,026	0,029	0,037	0,045	0,061	0,078	0,091	0,120	0,146	0,172	0,219
0,05xD	< 0,25xD	<b>85-110</b>	0,003	0,004	0,005	0,007	0,009	0,011	0,014	0,018	0,025	0,031	0,035	0,044	0,054	0,074	0,094	0,110	0,145	0,176	0,207	0,264
0,05xD	< 0,25xD	<b>60-85</b>	0,002	0,003	0,004	0,006	0,007	0,009	0,012	0,015	0,020	0,026	0,029	0,037	0,045	0,061	0,078	0,091	0,120	0,146	0,172	0,219
0,06xD	< 0,3xD	<b>250-300</b>	0,004	0,005	0,007	0,010	0,012	0,014	0,019	0,024	0,034	0,042	0,048	0,060	0,073	0,101	0,128	0,150	0,198	0,240	0,282	0,360
0,06xD	< 0,3xD	<b>250-300</b>	0,003	0,004	0,006	0,008	0,010	0,012	0,016	0,020	0,028	0,035	0,040	0,050	0,061	0,084	0,107	0,125	0,165	0,200	0,235	0,300
0,06xD	< 0,3xD	<b>240-280</b>	0,003	0,004	0,006	0,008	0,010	0,012	0,016	0,020	0,028	0,035	0,040	0,050	0,061	0,084	0,107	0,125	0,165	0,200	0,235	0,300
0,06xD	< 0,3xD	<b>240-280</b>	0,003	0,004	0,005	0,007	0,009	0,011	0,014	0,018	0,025	0,031	0,035	0,044	0,054	0,074	0,094	0,110	0,145	0,176	0,207	0,264
0,06xD	< 0,3xD	<b>250-300</b>	0,002	0,003	0,004	0,006	0,007	0,009	0,012	0,015	0,020	0,026	0,029	0,037	0,045	0,061	0,078	0,091	0,120	0,146	0,172	0,219
0,06xD	< 0,3xD	<b>240-280</b>	0,002	0,002	0,004	0,005	0,006	0,007	0,010	0,012	0,017	0,022	0,025	0,031	0,038	0,052	0,066	0,078	0,102	0,124	0,146	0,186
0,04xD	< 0,18xD	<b>220-280</b>	0,002	0,003	0,004	0,006	0,007	0,009	0,012	0,015	0,020	0,026	0,029	0,037	0,045	0,061	0,078	0,091	0,120	0,146	0,172	0,219
0,03xD	< 0,12xD	<b>160-220</b>	0,002	0,002	0,004	0,005	0,006	0,007	0,010	0,012	0,017	0,021	0,024	0,030	0,037	0,050	0,064	0,075	0,099	0,120	0,141	0,180
0,015xD	< 0,03xD	<b>100-160</b>	0,001	0,002	0,002	0,003	0,004	0,005	0,006	0,008	0,011	0,014	0,016	0,020	0,024	0,034	0,043	0,050	0,066	0,080	0,094	0,120

Die angegebenen Arbeitswerte sind Richtwerte.

Die für den jeweiligen Bearbeitungsfall optimalen Daten sollten im Versuch oder während der Bearbeitung ermittelt werden.

# Schnittwertempfehlung für Kugelfräser

Vorschub und Schnittgeschwindigkeit

## OptiMill-3D-BN | TBN101, TBN104

MZG*	Werkstoff	Festigkeit/Härte [N/mm <sup>2</sup> ] [HRC]	Kühlung			
			Trocken	Luft/MMS	KSS	
P	P1.1	Bau-, Automaten-, Einsatz- und Vergütungsstähle, unlegiert	< 700	✓	✓	✓
	P1.2	Bau-, Automaten-, Einsatz- und Vergütungsstähle, unlegiert	< 1.200	✓	✓	✓
	P2.1	Nitrier-, Einsatz- und Vergütungsstähle, legiert	< 900	✓	✓	✓
	P2.2	Nitrier-, Einsatz- und Vergütungsstähle, legiert	< 1.400	✓	✓	✓
	P3.1	Werkzeug-, Wälzlager-, Feder- und Schnellarbeitsstähle**	< 800	✓	✓	✓
	P3.2	Werkzeug-, Wälzlager-, Feder- und Schnellarbeitsstähle**	< 1.000	✓	✓	✓
	P3.3	Werkzeug-, Wälzlager-, Feder- und Schnellarbeitsstähle**	< 1.500	✓	✓	✓
	P4.1	Rostfreie Stähle, ferritisch und martensitisch			✓	✓
	P5.1	Stahlguss			✓	✓
	P6.1	Rostfreier Stahlguss, ferritisch und martensitisch			✓	✓
M	M1.1	Rostfreie Stähle, austenitisch	< 700			✓
	M1.2	Rostfreie Stähle, ferritisch/austenitisch (Duplex)	< 1.000			✓
	M2.1	Rostfreier Stahlguss, austenitisch	< 700			✓
	M3.1	Rostfreier Stahlguss, ferritisch/austenitisch (Duplex)	< 1.000			✓
K	K1.1	Gusseisen mit Lamellengraphit (Grauguss), GJL	< 300	✓	✓	✓
	K2.1	Gusseisen mit Kugelgraphit, GJS	< 500	✓	✓	✓
	K2.2	Gusseisen mit Kugelgraphit, GJS	≤ 800	✓	✓	✓
	K2.3	Gusseisen mit Kugelgraphit, GJS	> 800	✓	✓	✓
	K3.1	Gusseisen mit Vermiculargraphit, GJV; Temperguss, GJM	< 500	✓	✓	✓
	K3.2	Gusseisen mit Vermiculargraphit, GJV; Temperguss, GJM	> 500	✓	✓	✓
H	H1.1	Gehärteter Stahl/Stahlguss	< 44 HRC	✓	✓	
	H1.2	Gehärteter Stahl/Stahlguss	< 55 HRC	✓	✓	
	H2.1	Gehärteter Stahl/Stahlguss	< 60 HRC		✓	

### Korrekturfaktor Arbeitstiefe - $k_{AT}$

AT	$k_{AT}$		
	$a_p$	n	$v_f$
≤ 3xD	1,00	1,00	1,00
≤ 5xD	0,80	0,90	0,90
≤ 6xD	0,70	0,85	0,85
≤ 8xD	0,60	0,75	0,75
≤ 10xD	0,50	0,70	0,70
≤ 12xD	0,45***	0,65	0,65
≤ 15xD	0,40***	0,60	0,60
≤ 20xD	0,35***	0,60	0,60
≤ 25xD	0,35***	0,50	0,50
≤ 30xD	0,30***	0,50	0,50
≤ 35xD	0,30***	0,50	0,50

### Korrekturfaktor Konuswinkel - $k_{KW}$

$\varphi$ [°]	$k_{KW}$		
	$a_p$	n	$v_f$
0	1,00	1,00	1,00
0,5	1,01	1,01	1,01
1	1,02	1,02	1,02
1,5	1,03	1,03	1,03
3	1,06	1,06	1,06

#### Hinweis:

Für die Ermittlung der Schnittwerte bitte die Hinweise auf den Seiten 520-523 beachten.

\* MILLER Zerspanungsgruppen

\*\* Wenn die Legierungsbestandteile Cr, Mo, Ni, V, W in Summe > 8 %, dann die nächst höhere MILLER Zerspanungsgruppe wählen.

\*\*\* Rücksprache mit einem MILLER Anwendungstechniker.

Schlichten

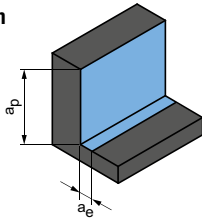

Eintauchwinkel  
0,5° - 1,0°

	a <sub>p</sub> [mm]	a <sub>e</sub> [mm]	v <sub>c</sub> [m/min]	f <sub>z</sub> [mm]																		
				Fräserdurchmesser [mm]																		
				0,10	0,20	0,30	0,40	0,50	0,60	0,80	1,00	1,50	1,80	2,00	2,50	3,00	4,00	5,00	6,00	8,00	10,00	12,00
0,015xD	0,025xD	<b>280-340</b>	0,003	0,004	0,006	0,008	0,010	0,011	0,015	0,019	0,027	0,033	0,038	0,048	0,058	0,080	0,102	0,119	0,157	0,190	0,223	0,285
0,014xD	0,024xD	<b>280-320</b>	0,003	0,003	0,005	0,007	0,008	0,010	0,013	0,017	0,023	0,029	0,033	0,042	0,051	0,070	0,089	0,105	0,138	0,167	0,196	0,251
0,014xD	0,024xD	<b>270-320</b>	0,003	0,004	0,006	0,008	0,010	0,011	0,015	0,019	0,027	0,033	0,038	0,048	0,058	0,080	0,102	0,119	0,157	0,190	0,223	0,285
0,013xD	0,023xD	<b>260-300</b>	0,003	0,003	0,005	0,007	0,008	0,010	0,013	0,017	0,023	0,029	0,033	0,042	0,051	0,070	0,089	0,105	0,138	0,167	0,196	0,251
0,013xD	0,023xD	<b>280-320</b>	0,003	0,004	0,005	0,007	0,009	0,011	0,014	0,018	0,025	0,032	0,036	0,045	0,055	0,076	0,097	0,113	0,149	0,181	0,212	0,271
0,012xD	0,022xD	<b>260-300</b>	0,002	0,003	0,005	0,006	0,008	0,010	0,013	0,016	0,022	0,028	0,032	0,040	0,048	0,067	0,085	0,099	0,131	0,159	0,187	0,238
0,01xD	0,02xD	<b>240-280</b>	0,002	0,003	0,004	0,006	0,007	0,008	0,011	0,014	0,019	0,024	0,028	0,035	0,042	0,058	0,074	0,087	0,114	0,139	0,163	0,208
0,013xD	0,023xD	<b>260-300</b>	0,003	0,004	0,006	0,008	0,010	0,011	0,015	0,019	0,027	0,033	0,038	0,048	0,058	0,080	0,102	0,119	0,157	0,190	0,223	0,285
0,013xD	0,023xD	<b>260-300</b>	0,003	0,003	0,005	0,007	0,008	0,010	0,013	0,017	0,023	0,029	0,033	0,042	0,051	0,070	0,089	0,105	0,138	0,167	0,196	0,251
0,012xD	0,022xD	<b>220-270</b>	0,002	0,003	0,004	0,006	0,007	0,008	0,011	0,014	0,019	0,024	0,028	0,035	0,042	0,058	0,074	0,087	0,114	0,139	0,163	0,208
0,013xD	0,023xD	<b>90-120</b>	0,003	0,003	0,005	0,007	0,008	0,010	0,013	0,017	0,023	0,029	0,033	0,042	0,051	0,070	0,089	0,105	0,138	0,167	0,196	0,251
0,012xD	0,022xD	<b>70-90</b>	0,002	0,003	0,004	0,006	0,007	0,008	0,011	0,014	0,019	0,024	0,028	0,035	0,042	0,058	0,074	0,087	0,114	0,139	0,163	0,208
0,013xD	0,023xD	<b>90-120</b>	0,003	0,003	0,005	0,007	0,008	0,010	0,013	0,017	0,023	0,029	0,033	0,042	0,051	0,070	0,089	0,105	0,138	0,167	0,196	0,251
0,012xD	0,022xD	<b>70-90</b>	0,002	0,003	0,004	0,006	0,007	0,008	0,011	0,014	0,019	0,024	0,028	0,035	0,042	0,058	0,074	0,087	0,114	0,139	0,163	0,208
0,015xD	0,025xD	<b>280-340</b>	0,003	0,004	0,006	0,008	0,010	0,011	0,015	0,019	0,027	0,033	0,038	0,048	0,058	0,080	0,102	0,119	0,157	0,190	0,223	0,285
0,014xD	0,024xD	<b>280-320</b>	0,003	0,003	0,005	0,007	0,008	0,010	0,013	0,017	0,023	0,029	0,033	0,042	0,051	0,070	0,089	0,105	0,138	0,167	0,196	0,251
0,013xD	0,023xD	<b>270-320</b>	0,003	0,003	0,005	0,007	0,008	0,010	0,013	0,017	0,023	0,029	0,033	0,042	0,051	0,070	0,089	0,105	0,138	0,167	0,196	0,251
0,012xD	0,022xD	<b>260-300</b>	0,003	0,003	0,005	0,007	0,008	0,010	0,013	0,017	0,023	0,029	0,033	0,042	0,051	0,070	0,089	0,105	0,138	0,167	0,196	0,251
0,014xD	0,024xD	<b>280-320</b>	0,002	0,003	0,004	0,006	0,007	0,008	0,011	0,014	0,019	0,024	0,028	0,035	0,042	0,058	0,074	0,087	0,114	0,139	0,163	0,208
0,013xD	0,023xD	<b>260-300</b>	0,002	0,002	0,004	0,005	0,006	0,007	0,009	0,012	0,017	0,021	0,024	0,029	0,036	0,050	0,063	0,074	0,097	0,118	0,139	0,177
0,012xD	0,022xD	<b>240-280</b>	0,002	0,003	0,004	0,006	0,007	0,009	0,012	0,014	0,020	0,025	0,029	0,036	0,044	0,061	0,077	0,090	0,119	0,144	0,170	0,217
0,01xD	0,02xD	<b>160-240</b>	0,002	0,003	0,004	0,005	0,007	0,008	0,011	0,014	0,019	0,024	0,027	0,034	0,042	0,058	0,073	0,086	0,113	0,137	0,161	0,206
0,008xD	0,018xD	<b>120-160</b>	0,001	0,002	0,003	0,004	0,005	0,006	0,008	0,010	0,013	0,017	0,019	0,024	0,029	0,040	0,051	0,060	0,079	0,096	0,113	0,144

Die angegebenen Arbeitswerte sind Richtwerte.

Die für den jeweiligen Bearbeitungsfall optimalen Daten sollten im Versuch oder während der Bearbeitung ermittelt werden.

# Schnittwertempfehlung für Kugelfräser

Vorschub und Schnittgeschwindigkeit

## OptiMill-3D-BN-Hardened | TBN107, TBN109

MZG*	Werkstoff	Festigkeit/Härte [N/mm <sup>2</sup> ] [HRC]	Kühlung				
			Trocken	Luft/MMS	KSS		
P	P1.1	Bau-, Automaten-, Einsatz- und Vergütungsstähle, unlegiert	< 700	✓	✓	✓	
	P1.2	Bau-, Automaten-, Einsatz- und Vergütungsstähle, unlegiert	< 1.200	✓	✓	✓	
	P2.1	Nitrier-, Einsatz- und Vergütungsstähle, legiert	< 900	✓	✓	✓	
	P2.2	Nitrier-, Einsatz- und Vergütungsstähle, legiert	< 1.400	✓	✓	✓	
	P3.1	Werkzeug-, Wälzlager-, Feder- und Schnellarbeitsstähle**	< 800	✓	✓	✓	
	P3.2	Werkzeug-, Wälzlager-, Feder- und Schnellarbeitsstähle**	< 1.000	✓	✓	✓	
	P3.3	Werkzeug-, Wälzlager-, Feder- und Schnellarbeitsstähle**	< 1.500	✓	✓	✓	
	P4.1	Rostfreie Stähle, ferritisch und martensitisch			✓	✓	
	P5.1	Stahlguss			✓	✓	
	P6.1	Rostfreier Stahlguss, ferritisch und martensitisch			✓	✓	
	K	K1.1	Gusseisen mit Lamellengraphit (Grauguss), GJL	< 300	✓	✓	✓
		K2.1	Gusseisen mit Kugelgraphit, GJS	< 500	✓	✓	✓
K2.2		Gusseisen mit Kugelgraphit, GJS	≤ 800	✓	✓	✓	
K2.3		Gusseisen mit Kugelgraphit, GJS	> 800	✓	✓	✓	
K3.1		Gusseisen mit Vermiculargraphit, GJV; Temperguss, GJM	< 500	✓	✓	✓	
K3.2		Gusseisen mit Vermiculargraphit, GJV; Temperguss, GJM	> 500	✓	✓	✓	
H	H1.1	Gehärteter Stahl/Stahlguss	< 44 HRC	✓	✓		
	H1.2	Gehärteter Stahl/Stahlguss	< 55 HRC	✓	✓		
	H2.1	Gehärteter Stahl/Stahlguss	< 60 HRC		✓		
	H2.2	Gehärteter Stahl/Stahlguss	< 65 HRC		✓		
	H2.3	Gehärteter Stahl/Stahlguss	< 68 HRC		✓		
	H3.1	Verschleißbeständiger Guss/Hartguss, GJN		✓	✓		

### Korrekturfaktor Arbeitstiefe - $k_{AT}$

AT	$k_{AT}$		
	$a_p$	n	$v_f$
≤ 3xD	1,00	1,00	1,00
≤ 5xD	0,80	0,90	0,90
≤ 6xD	0,70	0,85	0,85
≤ 8xD	0,60	0,75	0,75
≤ 10xD	0,50	0,70	0,70
≤ 12xD	0,45***	0,65	0,65
≤ 15xD	0,40***	0,60	0,60
≤ 20xD	0,35***	0,60	0,60
≤ 25xD	0,35***	0,50	0,50
≤ 30xD	0,30***	0,50	0,50
≤ 35xD	0,30***	0,50	0,50

### Korrekturfaktor Konuswinkel - $k_{KW}$

$\varphi$ [°]	$k_{KW}$		
	$a_p$	n	$v_f$
0	1,00	1,00	1,00
0,5	1,01	1,01	1,01
1	1,02	1,02	1,02
1,5	1,03	1,03	1,03
3	1,06	1,06	1,06

#### Hinweis:

Für die Ermittlung der Schnittwerte bitte die Hinweise auf den Seiten 520-523 beachten.

\* MILLER Zerspanungsgruppen

\*\* Wenn die Legierungsbestandteile Cr, Mo, Ni, V, W in Summe > 8 %, dann die nächst höhere MILLER Zerspanungsgruppe wählen.

\*\*\* Rücksprache mit einem MILLER Anwendungstechniker.



Schruppen

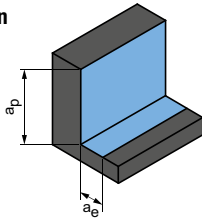

Eintauchwinkel  
1,0° - 3,0°

Nächste Seite:  
**Schlichten**

a <sub>p</sub> [mm]	a <sub>e</sub> [mm]	v <sub>c</sub> [m/min]	f <sub>z</sub> [mm]																			
			Fräserdurchmesser [mm]																			
			0,10	0,20	0,30	0,40	0,50	0,60	0,80	1,00	1,50	1,80	2,00	2,50	3,00	4,00	5,00	6,00	8,00	10,00	12,00	16,00
0,05xD	< 0,25xD	<b>250-300</b>	0,003	0,004	0,006	0,008	0,010	0,012	0,016	0,020	0,028	0,035	0,040	0,050	0,061	0,084	0,107	0,125	0,165	0,200	0,235	0,300
0,045xD	< 0,25xD	<b>240-280</b>	0,003	0,004	0,005	0,007	0,009	0,011	0,014	0,018	0,025	0,031	0,035	0,044	0,054	0,074	0,094	0,110	0,145	0,176	0,207	0,264
0,05xD	< 0,25xD	<b>250-300</b>	0,003	0,004	0,006	0,008	0,010	0,012	0,016	0,020	0,028	0,035	0,040	0,050	0,061	0,084	0,107	0,125	0,165	0,200	0,235	0,300
0,045xD	< 0,25xD	<b>240-280</b>	0,003	0,004	0,005	0,007	0,009	0,011	0,014	0,018	0,025	0,031	0,035	0,044	0,054	0,074	0,094	0,110	0,145	0,176	0,207	0,264
0,05xD	< 0,25xD	<b>250-300</b>	0,003	0,004	0,006	0,008	0,010	0,011	0,015	0,019	0,027	0,033	0,038	0,048	0,058	0,080	0,102	0,119	0,157	0,190	0,223	0,285
0,045xD	< 0,2xD	<b>240-280</b>	0,003	0,004	0,005	0,007	0,009	0,011	0,014	0,018	0,025	0,031	0,035	0,044	0,054	0,074	0,094	0,110	0,145	0,176	0,207	0,264
0,04xD	< 0,2xD	<b>220-260</b>	0,002	0,003	0,004	0,006	0,007	0,009	0,012	0,015	0,020	0,026	0,029	0,037	0,045	0,061	0,078	0,091	0,120	0,146	0,172	0,219
0,05xD	< 0,25xD	<b>240-280</b>	0,003	0,004	0,006	0,008	0,010	0,012	0,016	0,020	0,028	0,035	0,040	0,050	0,061	0,084	0,107	0,125	0,165	0,200	0,235	0,300
0,05xD	< 0,25xD	<b>240-280</b>	0,003	0,004	0,005	0,007	0,009	0,011	0,014	0,018	0,025	0,031	0,035	0,044	0,054	0,074	0,094	0,110	0,145	0,176	0,207	0,264
0,045xD	< 0,25xD	<b>200-250</b>	0,002	0,003	0,004	0,006	0,007	0,009	0,012	0,015	0,020	0,026	0,029	0,037	0,045	0,061	0,078	0,091	0,120	0,146	0,172	0,219
0,06xD	< 0,3xD	<b>250-300</b>	0,004	0,005	0,007	0,010	0,012	0,014	0,019	0,024	0,034	0,042	0,048	0,060	0,073	0,101	0,128	0,150	0,198	0,240	0,282	0,360
0,06xD	< 0,3xD	<b>250-300</b>	0,003	0,004	0,006	0,008	0,010	0,012	0,016	0,020	0,028	0,035	0,040	0,050	0,061	0,084	0,107	0,125	0,165	0,200	0,235	0,300
0,06xD	< 0,3xD	<b>240-280</b>	0,003	0,004	0,006	0,008	0,010	0,012	0,016	0,020	0,028	0,035	0,040	0,050	0,061	0,084	0,107	0,125	0,165	0,200	0,235	0,300
0,06xD	< 0,3xD	<b>240-280</b>	0,003	0,004	0,005	0,007	0,009	0,011	0,014	0,018	0,025	0,031	0,035	0,044	0,054	0,074	0,094	0,110	0,145	0,176	0,207	0,264
0,06xD	< 0,3xD	<b>250-300</b>	0,002	0,003	0,004	0,006	0,007	0,009	0,012	0,015	0,020	0,026	0,029	0,037	0,045	0,061	0,078	0,091	0,120	0,146	0,172	0,219
0,06xD	< 0,3xD	<b>240-280</b>	0,002	0,002	0,004	0,005	0,006	0,007	0,010	0,012	0,017	0,022	0,025	0,031	0,038	0,052	0,066	0,078	0,102	0,124	0,146	0,186
0,04xD	< 0,18xD	<b>220-280</b>	0,002	0,003	0,004	0,006	0,007	0,009	0,012	0,015	0,020	0,026	0,029	0,037	0,045	0,061	0,078	0,091	0,120	0,146	0,172	0,219
0,03xD	< 0,12xD	<b>160-220</b>	0,002	0,002	0,004	0,005	0,006	0,007	0,010	0,012	0,017	0,021	0,024	0,030	0,037	0,050	0,064	0,075	0,099	0,120	0,141	0,180
0,015xD	< 0,03xD	<b>100-160</b>	0,001	0,002	0,002	0,003	0,004	0,005	0,006	0,008	0,011	0,014	0,016	0,020	0,024	0,034	0,043	0,050	0,066	0,080	0,094	0,120
0,008xD	< 0,018xD	<b>60-100</b>	0,001	0,001	0,002	0,002	0,003	0,004	0,005	0,006	0,008	0,011	0,012	0,015	0,018	0,025	0,032	0,038	0,050	0,060	0,071	0,090
0,005xD	< 0,015xD	<b>40-80</b>	0,001	0,001	0,001	0,002	0,002	0,003	0,004	0,004	0,006	0,008	0,009	0,011	0,013	0,019	0,024	0,028	0,036	0,044	0,052	0,066
0,015xD	< 0,03xD	<b>100-160</b>	0,001	0,002	0,002	0,003	0,004	0,005	0,006	0,008	0,011	0,014	0,016	0,020	0,024	0,034	0,043	0,050	0,066	0,080	0,094	0,120

Die angegebenen Arbeitswerte sind Richtwerte.

Die für den jeweiligen Bearbeitungsfall optimalen Daten sollten im Versuch oder während der Bearbeitung ermittelt werden.

# Schnittwertempfehlung für Kugelfräser

Vorschub und Schnittgeschwindigkeit

## OptiMill-3D-BN-Hardened | TBN107, TBN109

MZG*	Werkstoff	Festigkeit/Härte [N/mm <sup>2</sup> ] [HRC]	Kühlung				
			Trocken	Luft/MMS	KSS		
P	P1.1	Bau-, Automaten-, Einsatz- und Vergütungsstähle, unlegiert	< 700	✓	✓	✓	
	P1.2	Bau-, Automaten-, Einsatz- und Vergütungsstähle, unlegiert	< 1.200	✓	✓	✓	
	P2.1	Nitrier-, Einsatz- und Vergütungsstähle, legiert	< 900	✓	✓	✓	
	P2.2	Nitrier-, Einsatz- und Vergütungsstähle, legiert	< 1.400	✓	✓	✓	
	P3.1	Werkzeug-, Wälzlager-, Feder- und Schnellarbeitsstähle**	< 800	✓	✓	✓	
	P3.2	Werkzeug-, Wälzlager-, Feder- und Schnellarbeitsstähle**	< 1.000	✓	✓	✓	
	P3.3	Werkzeug-, Wälzlager-, Feder- und Schnellarbeitsstähle**	< 1.500	✓	✓	✓	
	P4.1	Rostfreie Stähle, ferritisch und martensitisch			✓	✓	
	P5.1	Stahlguss			✓	✓	
	P6.1	Rostfreier Stahlguss, ferritisch und martensitisch			✓	✓	
	K	K1.1	Gusseisen mit Lamellengraphit (Grauguss), GJL	< 300	✓	✓	✓
		K2.1	Gusseisen mit Kugelgraphit, GJS	< 500	✓	✓	✓
K2.2		Gusseisen mit Kugelgraphit, GJS	≤ 800	✓	✓	✓	
K2.3		Gusseisen mit Kugelgraphit, GJS	> 800	✓	✓	✓	
K3.1		Gusseisen mit Vermiculargraphit, GJV; Temperguss, GJM	< 500	✓	✓	✓	
K3.2		Gusseisen mit Vermiculargraphit, GJV; Temperguss, GJM	> 500	✓	✓	✓	
H	H1.1	Gehärteter Stahl/Stahlguss	< 44 HRC	✓	✓		
	H1.2	Gehärteter Stahl/Stahlguss	< 55 HRC	✓	✓		
	H2.1	Gehärteter Stahl/Stahlguss	< 60 HRC		✓		
	H2.2	Gehärteter Stahl/Stahlguss	< 65 HRC		✓		
	H2.3	Gehärteter Stahl/Stahlguss	< 68 HRC		✓		
	H3.1	Verschleißbeständiger Guss/Hartguss, GJN		✓	✓		

### Korrekturfaktor Arbeitstiefe - $k_{AT}$

AT	$k_{AT}$		
	$a_p$	n	$v_f$
≤ 3xD	1,00	1,00	1,00
≤ 5xD	0,80	0,90	0,90
≤ 6xD	0,70	0,85	0,85
≤ 8xD	0,60	0,75	0,75
≤ 10xD	0,50	0,70	0,70
≤ 12xD	0,45***	0,65	0,65
≤ 15xD	0,40***	0,60	0,60
≤ 20xD	0,35***	0,60	0,60
≤ 25xD	0,35***	0,50	0,50
≤ 30xD	0,30***	0,50	0,50
≤ 35xD	0,30***	0,50	0,50

### Korrekturfaktor Konuswinkel - $k_{KW}$

$\varphi$ [°]	$k_{KW}$		
	$a_p$	n	$v_f$
0	1,00	1,00	1,00
0,5	1,01	1,01	1,01
1	1,02	1,02	1,02
1,5	1,03	1,03	1,03
3	1,06	1,06	1,06

#### Hinweis:

Für die Ermittlung der Schnittwerte bitte die Hinweise auf den Seiten 520-523 beachten.

\* MILLER Zerspanungsgruppen

\*\* Wenn die Legierungsbestandteile Cr, Mo, Ni, V, W in Summe > 8 %, dann die nächst höhere MILLER Zerspanungsgruppe wählen.

\*\*\* Rücksprache mit einem MILLER Anwendungstechniker.

Schichten

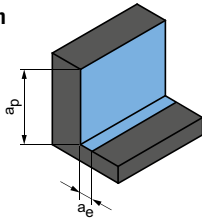

Eintauchwinkel  
0,5° - 1,0°

	a <sub>p</sub> [mm]	a <sub>e</sub> [mm]	v <sub>c</sub> [m/min]	f <sub>z</sub> [mm]																		
				Fräserdurchmesser [mm]																		
				0,10	0,20	0,30	0,40	0,50	0,60	0,80	1,00	1,50	1,80	2,00	2,50	3,00	4,00	5,00	6,00	8,00	10,00	12,00
0,015xD	0,025xD	<b>280-340</b>	0,003	0,004	0,006	0,008	0,010	0,011	0,015	0,019	0,027	0,033	0,038	0,048	0,058	0,080	0,102	0,119	0,157	0,190	0,223	0,285
0,014xD	0,024xD	<b>280-320</b>	0,003	0,003	0,005	0,007	0,008	0,010	0,013	0,017	0,023	0,029	0,033	0,042	0,051	0,070	0,089	0,105	0,138	0,167	0,196	0,251
0,014xD	0,024xD	<b>270-320</b>	0,003	0,004	0,006	0,008	0,010	0,011	0,015	0,019	0,027	0,033	0,038	0,048	0,058	0,080	0,102	0,119	0,157	0,190	0,223	0,285
0,013xD	0,023xD	<b>260-300</b>	0,003	0,003	0,005	0,007	0,008	0,010	0,013	0,017	0,023	0,029	0,033	0,042	0,051	0,070	0,089	0,105	0,138	0,167	0,196	0,251
0,013xD	0,023xD	<b>280-320</b>	0,003	0,004	0,005	0,007	0,009	0,011	0,014	0,018	0,025	0,032	0,036	0,045	0,055	0,076	0,097	0,113	0,149	0,181	0,212	0,271
0,012xD	0,022xD	<b>260-300</b>	0,003	0,003	0,005	0,007	0,008	0,010	0,013	0,017	0,023	0,029	0,033	0,042	0,051	0,070	0,089	0,105	0,138	0,167	0,196	0,251
0,01xD	0,02xD	<b>240-280</b>	0,002	0,003	0,004	0,006	0,007	0,008	0,011	0,014	0,019	0,024	0,028	0,035	0,042	0,058	0,074	0,087	0,114	0,139	0,163	0,208
0,013xD	0,023xD	<b>260-300</b>	0,003	0,004	0,006	0,008	0,010	0,011	0,015	0,019	0,027	0,033	0,038	0,048	0,058	0,080	0,102	0,119	0,157	0,190	0,223	0,285
0,013xD	0,023xD	<b>260-300</b>	0,003	0,003	0,005	0,007	0,008	0,010	0,013	0,017	0,023	0,029	0,033	0,042	0,051	0,070	0,089	0,105	0,138	0,167	0,196	0,251
0,012xD	0,022xD	<b>220-270</b>	0,002	0,003	0,004	0,006	0,007	0,008	0,011	0,014	0,019	0,024	0,028	0,035	0,042	0,058	0,074	0,087	0,114	0,139	0,163	0,208
0,015xD	0,025xD	<b>280-340</b>	0,003	0,004	0,006	0,008	0,010	0,011	0,015	0,019	0,027	0,033	0,038	0,048	0,058	0,080	0,102	0,119	0,157	0,190	0,223	0,285
0,014xD	0,024xD	<b>280-320</b>	0,003	0,003	0,005	0,007	0,008	0,010	0,013	0,017	0,023	0,029	0,033	0,042	0,051	0,070	0,089	0,105	0,138	0,167	0,196	0,251
0,013xD	0,023xD	<b>270-320</b>	0,003	0,003	0,005	0,007	0,008	0,010	0,013	0,017	0,023	0,029	0,033	0,042	0,051	0,070	0,089	0,105	0,138	0,167	0,196	0,251
0,012xD	0,022xD	<b>260-300</b>	0,003	0,003	0,005	0,007	0,008	0,010	0,013	0,017	0,023	0,029	0,033	0,042	0,051	0,070	0,089	0,105	0,138	0,167	0,196	0,251
0,014xD	0,024xD	<b>280-320</b>	0,002	0,003	0,004	0,006	0,007	0,008	0,011	0,014	0,019	0,024	0,028	0,035	0,042	0,058	0,074	0,087	0,114	0,139	0,163	0,208
0,013xD	0,023xD	<b>260-300</b>	0,002	0,002	0,004	0,005	0,006	0,007	0,009	0,012	0,017	0,021	0,024	0,029	0,036	0,050	0,063	0,074	0,097	0,118	0,139	0,177
0,012xD	0,022xD	<b>250-300</b>	0,003	0,004	0,005	0,007	0,009	0,011	0,015	0,018	0,026	0,032	0,037	0,046	0,056	0,077	0,098	0,114	0,151	0,183	0,215	0,274
0,01xD	0,02xD	<b>200-250</b>	0,002	0,003	0,005	0,007	0,008	0,010	0,013	0,017	0,023	0,029	0,033	0,041	0,051	0,070	0,089	0,104	0,137	0,166	0,195	0,249
0,008xD	0,018xD	<b>130-200</b>	0,002	0,003	0,005	0,006	0,008	0,009	0,012	0,015	0,021	0,026	0,030	0,038	0,046	0,063	0,081	0,094	0,124	0,151	0,177	0,226
0,006xD	0,016xD	<b>100-150</b>	0,002	0,003	0,004	0,005	0,007	0,008	0,011	0,014	0,019	0,024	0,027	0,034	0,042	0,058	0,073	0,086	0,113	0,137	0,161	0,206
0,005xD	0,015xD	<b>70-120</b>	0,001	0,002	0,003	0,004	0,005	0,006	0,008	0,010	0,013	0,017	0,019	0,024	0,029	0,040	0,051	0,060	0,079	0,096	0,113	0,144
0,008xD	0,018xD	<b>130-200</b>	0,002	0,003	0,005	0,006	0,008	0,009	0,012	0,015	0,021	0,026	0,030	0,038	0,046	0,063	0,081	0,094	0,124	0,151	0,177	0,226

Die angegebenen Arbeitswerte sind Richtwerte.

Die für den jeweiligen Bearbeitungsfall optimalen Daten sollten im Versuch oder während der Bearbeitung ermittelt werden.

# Schnittwertempfehlung für Kugelfräser

Vorschub und Schnittgeschwindigkeit

## OptiMill-3D-BN-Alu | TBN114, TBN116

MZG*	Werkstoff	Festigkeit/Härte [N/mm <sup>2</sup> ] [HRC]	Kühlung		
			Trocken	Luft/MMS	KSS
N	N1	N1.1 Aluminium, unlegiert und legiert < 3 % Si			✓
		N1.2 Aluminium, legiert ≤ 7 % Si			✓
		N1.3 Aluminium, legiert > 7-12 % Si			✓
		N1.4 Aluminium, legiert > 12 % Si			✓
N	N2	N2.1 Kupfer, unlegiert und niedriglegiert	< 300		✓
		N2.2 Kupfer, legiert	> 300		✓
		N2.3 Messing, Bronze, Rotguss	< 1.200	✓	✓

**Schruppen**

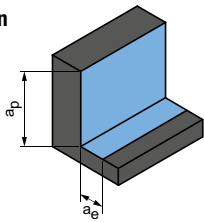

Eintauchwinkel  
1,0° - 3,0°

Nächste Seite:  
**Schlichten**

$a_p$ [mm]	$a_e$ [mm]	$v_c$ [m/min]	$f_z$ [mm]													
			Fräserdurchmesser [mm]													
			1,00	1,50	2,00	2,50	3,00	4,00	5,00	6,00	8,00	10,00	12,00	16,00	20,00	
0,1xD	< 0,3xD	<b>400-600</b>	0,022	0,030	0,038	0,045	0,057	0,062	0,082	0,090	0,102	0,120	0,155	0,180	0,205	
0,1xD	< 0,3xD	<b>380-580</b>	0,024	0,033	0,042	0,050	0,063	0,068	0,090	0,099	0,112	0,132	0,171	0,198	0,226	
0,1xD	< 0,3xD	<b>340-540</b>	0,026	0,036	0,046	0,054	0,068	0,074	0,098	0,108	0,122	0,144	0,186	0,216	0,246	
0,1xD	< 0,3xD	<b>300-500</b>	0,029	0,039	0,049	0,059	0,074	0,081	0,107	0,117	0,133	0,156	0,202	0,234	0,267	
0,1xD	< 0,3xD	<b>400-500</b>	0,022	0,030	0,038	0,045	0,057	0,062	0,082	0,090	0,102	0,120	0,155	0,180	0,205	
0,1xD	< 0,3xD	<b>300-400</b>	0,022	0,030	0,038	0,045	0,057	0,062	0,082	0,090	0,102	0,120	0,155	0,180	0,205	
0,1xD	< 0,3xD	<b>400-500</b>	0,026	0,036	0,046	0,054	0,068	0,074	0,098	0,108	0,122	0,144	0,186	0,216	0,246	

Die angegebenen Arbeitswerte sind Richtwerte.

Die für den jeweiligen Bearbeitungsfall optimalen Daten sollten im Versuch oder während der Bearbeitung ermittelt werden.

# Schnittwertempfehlung für Kugelfräser

Vorschub und Schnittgeschwindigkeit

## OptiMill-3D-BN-Alu | TBN114, TBN116

MZG*	Werkstoff	Festigkeit/Härte [N/mm <sup>2</sup> ] [HRC]	Kühlung		
			Trocken	Luft/MMS	KSS
N	N1	N1.1 Aluminium, unlegiert und legiert < 3 % Si			✓
		N1.2 Aluminium, legiert ≤ 7 % Si			✓
		N1.3 Aluminium, legiert > 7-12 % Si			✓
		N1.4 Aluminium, legiert > 12 % Si			✓
N	N2	N2.1 Kupfer, unlegiert und niedriglegiert	< 300		✓
		N2.2 Kupfer, legiert	> 300		✓
		N2.3 Messing, Bronze, Rotguss	< 1.200	✓	✓

### Korrekturfaktor Arbeitstiefe - $k_{AT}$

AT	$k_{AT}$		
	$a_p$	n	$v_f$
≤ 3xD	1,00	1,00	1,00
≤ 5xD	0,80	0,90	0,90
≤ 6xD	0,70	0,85	0,85
≤ 8xD	0,60	0,75	0,75
≤ 10xD	0,50	0,70	0,70
≤ 12xD	0,45**	0,65	0,65
≤ 15xD	0,40**	0,60	0,60
≤ 20xD	0,35**	0,60	0,60
≤ 25xD	0,35**	0,50	0,50
≤ 30xD	0,30**	0,50	0,50
≤ 35xD	0,30**	0,50	0,50

### Korrekturfaktor Konuswinkel - $k_{KW}$

$\varphi$ [°]	$k_{KW}$		
	$a_p$	n	$v_f$
0	1,00	1,00	1,00
0,5	1,01	1,01	1,01
1	1,02	1,02	1,02
1,5	1,03	1,03	1,03
3	1,06	1,06	1,06

#### Hinweis:

Für die Ermittlung der Schnittwerte bitte die Hinweise auf den Seiten 520-523 beachten.

\* MILLER Zerspanungsgruppen

\*\* Rücksprache mit einem MILLER Anwendungstechniker.

## Schichten

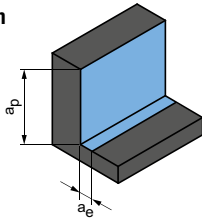

Eintauchwinkel  
0,5° - 1,0°

$a_p$ [mm]	$a_e$ [mm]	$v_c$ [m/min]	$f_z$ [mm]													
			Fräserdurchmesser [mm]													
			1,00	1,50	2,00	2,50	3,00	4,00	5,00	6,00	8,00	10,00	12,00	16,00	20,00	
0,015xD	0,025xD	<b>400-600</b>	0,022	0,030	0,038	0,045	0,057	0,062	0,082	0,090	0,102	0,120	0,155	0,180	0,205	
0,015xD	0,025xD	<b>380-580</b>	0,024	0,033	0,042	0,050	0,063	0,068	0,090	0,099	0,112	0,132	0,171	0,198	0,226	
0,015xD	0,025xD	<b>340-540</b>	0,026	0,036	0,046	0,054	0,068	0,074	0,098	0,108	0,122	0,144	0,186	0,216	0,246	
0,015xD	0,025xD	<b>300-500</b>	0,029	0,039	0,049	0,059	0,074	0,081	0,107	0,117	0,133	0,156	0,202	0,234	0,267	
0,015xD	0,025xD	<b>400-500</b>	0,022	0,030	0,038	0,045	0,057	0,062	0,082	0,090	0,102	0,120	0,155	0,180	0,205	
0,015xD	0,025xD	<b>300-400</b>	0,022	0,030	0,038	0,045	0,057	0,062	0,082	0,090	0,102	0,120	0,155	0,180	0,205	
0,015xD	0,025xD	<b>400-500</b>	0,026	0,036	0,046	0,054	0,068	0,074	0,098	0,108	0,122	0,144	0,186	0,216	0,246	

Die angegebenen Arbeitswerte sind Richtwerte.

Die für den jeweiligen Bearbeitungsfall optimalen Daten sollten im Versuch oder während der Bearbeitung ermittelt werden.

# Schnittwertempfehlung für Eckradiusfräser

Vorschub und Schnittgeschwindigkeit

Nutfräsen

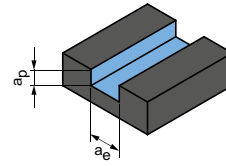

$$a_p = 1 \times D$$

$$a_e = 1 \times D$$

## OptiMill-Composite-Speed-Radius | M7828

MZG*	Werkstoff	Festigkeit/ Härte [N/mm <sup>2</sup> ] [HRC]	Kühlung			v <sub>c</sub> [m/min]	f <sub>z</sub> [mm]								
			MMS/Luft	Trocken	KSS		Fräserdurchmesser [mm]								
							4,00	6,00	8,00	10,00	12,00	16,00	20,00		
<b>N</b> N4	N4.1	Kunststoff, Thermoplaste				<b>150</b>									
	N4.2	Kunststoff, Duroplaste	✓	✓	✓		0,020	0,029	0,038	0,045	0,052	0,063	0,072		
	N4.3	Kunststoff, Schaumstoffe													
<b>C</b> C1 C2 C3 C4	C1.1	Kunststoffmatrix, Aramidfaserverstärkt (AFK)				<b>145</b>									
	C1.2	Kunststoffmatrix (duroplastisch), CFK/GFK	✓	✓	✓		0,021	0,026	0,031	0,035	0,038	0,042	0,043		
	C1.3	Kunststoffmatrix (thermoplastisch), CFK/GFK													
	C2.1	Kohlenstoffmatrix, Kohlenstofffaserverstärkt (CFC)	✓	✓	✓	<b>145</b>	0,018	0,023	0,027	0,031	0,033	0,037	0,038		
	C3.1	Metallmatrix (MMC)													
	C4.1	Sandwichkonstruktion, Wabenkern (Honeycomb)	✓	✓		<b>195</b>	0,012	0,015	0,017	0,019	0,021	0,023	0,024		
C4.2	Sandwichkonstruktion, Schaumkern	✓	✓		<b>150</b>	0,019	0,024	0,028	0,032	0,035	0,039	0,041			



**Schruppen**

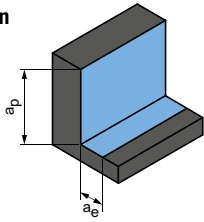

$$a_p = 1,5xD$$

$$a_e = 0,25xD$$

**Schlichten**

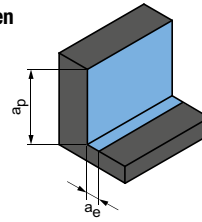

$$a_p = 1,5xD$$

$$a_e = 0,1xD$$

	$v_c$ [m/min]	$f_z$ [mm]							$v_c$ [m/min]	$f_z$ [mm]						
		Fräserdurchmesser [mm]								Fräserdurchmesser [mm]						
		4,00	6,00	8,00	10,00	12,00	16,00	20,00		4,00	6,00	8,00	10,00	12,00	16,00	20,00
<b>230</b>	0,029	0,041	0,053	0,063	0,072	0,089	0,101	<b>275</b>	0,040	0,057	0,073	0,088	0,101	0,123	0,141	
<b>240</b>	0,021	0,026	0,031	0,035	0,038	0,042	0,043	<b>355</b>	0,021	0,026	0,031	0,035	0,038	0,042	0,043	
<b>240</b>	0,018	0,023	0,027	0,031	0,033	0,037	0,038	<b>355</b>	0,018	0,023	0,027	0,031	0,033	0,037	0,038	
<b>325</b>	0,012	0,015	0,017	0,019	0,021	0,023	0,024	<b>480</b>	0,012	0,015	0,017	0,019	0,021	0,023	0,024	
<b>245</b>	0,019	0,024	0,028	0,032	0,035	0,039	0,041	<b>360</b>	0,019	0,024	0,028	0,032	0,035	0,039	0,041	

Die angegebenen Arbeitswerte sind Richtwerte.

Die für den jeweiligen Bearbeitungsfall optimalen Daten sollten im Versuch oder während der Bearbeitung ermittelt werden.



# FASEN, ENTGRATEN UND BOHRFRÄSEN

## Universeller Einsatz

---

OptiMill-Chamfer ..... 500

OptiMill-DrillMill ..... 501

## Technischer Anhang

---

Schnittwertempfehlung ..... 502

# OptiMill®-Chamfer

Kurze Ausführung  
M5390

**Ausführung:**

Fräserdurchmesser: 4,00 - 20,00 mm  
Beschichtung: MF4  
Schneidenzahl: 4  
Spitzenwinkel: 90°  
Spiralwinkel: 0°

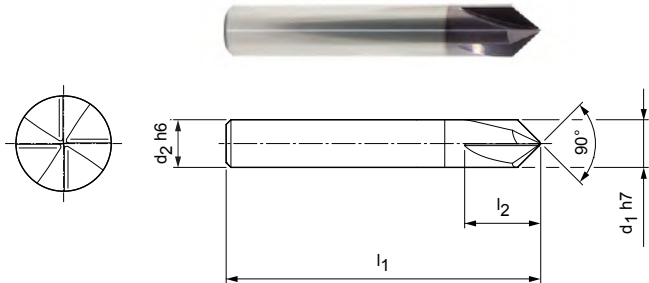

## Lagerhaltige Vorzugsbaureihe

Baumaße				z	Spezifikation	Bestell-Nr.
d <sub>1</sub> h7	d <sub>2</sub> h6	l <sub>1</sub>	l <sub>2</sub>			
4,00	4	54	9	4	M5390-0400AZ	30247388
6,00	6	54	12	4	M5390-0600AZ	30241828
8,00	8	58	15	4	M5390-0800AZ	30241829
10,00	10	66	16	4	M5390-1000AZ	30241830
12,00	12	73	18	4	M5390-1200AZ	30241831
16,00	16	82	25	4	M5390-1600AZ	30269759
20,00	20	92	30	4	M5390-2000AZ	30269760

## Konfigurierbare Merkmale

**Schaftform:**  
Schaftform: HB

**Spezifikation:**  
M5390-1200[Schaftform]Z

Beispiel:  
M5390-1200BZ

Schaftform HB

Maßangaben in mm.

Schnittwertempfehlung siehe Kapitelende.

Sonderausführungen und andere Beschichtungen auf Anfrage.

# OptiMill®-DrillMill

Lange Ausführung mit Bohrspitze  
M5490

**Ausführung:**

Fräserdurchmesser: 3,00 - 16,00 mm  
 Beschichtung: Unbeschichtet  
 Schneidenzahl: 2  
 Spitzenwinkel: 90°  
 Spiralwinkel: 30°

**Anwendung:**

Bohrfräser zum Fräsen, Fasen, Anbohren und Bohren.

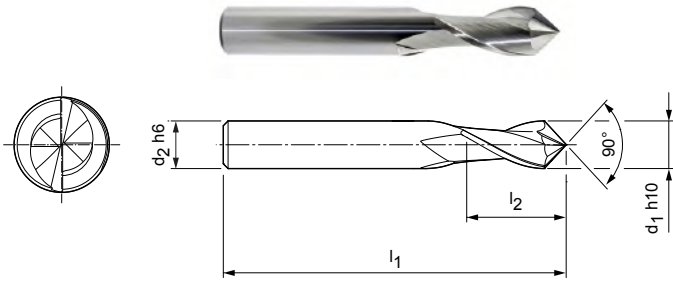

**Lagerhaltige Vorzugsbaureihe**

Baumaße				z	Spezifikation	Bestell-Nr.
d1 h10	d2 h6	l1	l2			
3,00	6	57	8	2	M5490-0300AU SPW90°	30247237
4,00	6	57	11	2	M5490-0400AU SPW90°	30247238
5,00	6	57	13	2	M5490-0500AU SPW90°	30247239
6,00	6	57	13	2	M5490-0600AU SPW90°	30247240
8,00	8	63	19	2	M5490-0800AU SPW90°	30247241
10,00	10	72	22	2	M5490-1000AU SPW90°	30247242
12,00	12	83	26	2	M5490-1200AU SPW90°	30247243
16,00	16	92	32	2	M5490-1600AU SPW90°	30269758

**Konfigurierbare Merkmale**



**Schaftform:**  
Schaftform: HB



**Spezifikation:**  
M5490-1200[Schaftform]U SPW90°

**Beispiel:**  
M5490-1200BU SPW90°

\_\_\_\_\_ Schaftform HB

Maßangaben in mm.  
 Schnittwertempfehlung siehe Kapitelende.  
 Sonderausführungen und andere Beschichtungen auf Anfrage.

# Schnittwertempfehlung für Radius- und Entgratfräser

Vorschub und Schnittgeschwindigkeit

## OptiMill-Chamfer | M5390

MZG*	Werkstoff	Festigkeit/Härte [N/mm <sup>2</sup> ] [HRC]	Kühlung			
			MMS/Luft	Trocken	KSS	
P	P1.1	Bau-, Automaten-, Einsatz- und Vergütungsstähle, unlegiert	< 700	✓	✓	✓
	P1.2	Bau-, Automaten-, Einsatz- und Vergütungsstähle, unlegiert	< 1.200	✓	✓	✓
	P2.1	Nitrier-, Einsatz- und Vergütungsstähle, legiert	< 900	✓	✓	✓
	P2.2	Nitrier-, Einsatz- und Vergütungsstähle, legiert	< 1.400	✓		✓
	P3.1	Werkzeug-, Wälzlager-, Feder- und Schnellarbeitsstähle**	< 800	✓	✓	✓
	P3.2	Werkzeug-, Wälzlager-, Feder- und Schnellarbeitsstähle**	< 1.000	✓		✓
	P3.3	Werkzeug-, Wälzlager-, Feder- und Schnellarbeitsstähle**	< 1.500	✓		✓
	P4.1	Rostfreie Stähle, ferritisch und martensitisch		✓		✓
	P5.1	Stahlguss				✓
	P6.1	Rostfreier Stahlguss, ferritisch und martensitisch				✓
M	M1.1	Rostfreie Stähle, austenitisch	< 700	✓		✓
	M1.2	Rostfreie Stähle, ferritisch/austenitisch (Duplex)	< 1.000			✓
	M2.1	Rostfreier Stahlguss, austenitisch	< 700	✓		✓
	M3.1	Rostfreier Stahlguss, ferritisch/austenitisch (Duplex)	< 1.000			✓
K	K1.1	Gusseisen mit Lamellengraphit (Grauguss), GJL	< 300	✓	✓	✓
	K2.1	Gusseisen mit Kugelgraphit, GJS	< 500	✓	✓	✓
	K2.2	Gusseisen mit Kugelgraphit, GJS	500-800	✓	✓	✓
	K2.3	Gusseisen mit Kugelgraphit, GJS	> 800	✓	✓	✓
	K3.1	Gusseisen mit Vermiculargraphit, GJV; Temperguss, GJM	< 500	✓	✓	✓
	K3.2	Gusseisen mit Vermiculargraphit, GJV; Temperguss, GJM	> 500	✓	✓	✓
N	N1.1	Aluminium, unlegiert und legiert <3 % Si		✓	✓	✓
	N1.2	Aluminium, legiert ≤ 7 % Si		✓	✓	✓
	N1.3	Aluminium, legiert > 7-12 % Si		✓	✓	✓
	N1.4	Aluminium, legiert > 12 % Si		✓	✓	✓
	N2.1	Kupfer, unlegiert und niedriglegiert	< 300	✓	✓	✓
	N2.2	Kupfer, legiert	> 300	✓	✓	✓
	N2.3	Messing, Bronze, Rotguss	< 1.200	✓	✓	✓

\* MILLER Zerspanungsgruppen

\*\* Wenn die Legierungsbestandteile Cr, Mo, Ni, V, W in Summe > 8 %, dann die nächst höhere MILLER Zerspanungsgruppe wählen.

Schichten

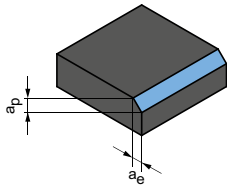

$a_p = 0,1xD$   
 $a_e = 0,1xD$

	$v_c$ [m/min]	$f_z$ [mm]						
		Fräserdurchmesser [mm]						
		4,00	6,00	8,00	10,00	12,00	16,00	20,00
	<b>215</b>	0,043	0,061	0,078	0,094	0,108	0,132	0,151
	<b>175</b>	0,040	0,057	0,073	0,088	0,101	0,123	0,141
	<b>195</b>	0,043	0,061	0,078	0,094	0,108	0,132	0,151
	<b>140</b>	0,036	0,051	0,065	0,078	0,090	0,110	0,125
	<b>130</b>	0,041	0,059	0,076	0,091	0,104	0,127	0,146
	<b>120</b>	0,039	0,056	0,072	0,086	0,099	0,121	0,138
	<b>110</b>	0,037	0,053	0,068	0,081	0,093	0,114	0,131
	<b>90</b>	0,028	0,041	0,052	0,063	0,072	0,088	0,100
	<b>130</b>	0,041	0,059	0,076	0,091	0,104	0,127	0,146
	<b>90</b>	0,020	0,029	0,037	0,044	0,050	0,061	0,070
	<b>75</b>	0,025	0,036	0,046	0,055	0,063	0,077	0,088
	<b>70</b>	0,021	0,030	0,038	0,045	0,052	0,064	0,073
	<b>80</b>	0,027	0,039	0,050	0,059	0,068	0,083	0,095
	<b>75</b>	0,021	0,031	0,039	0,047	0,054	0,066	0,075
	<b>290</b>	0,071	0,102	0,131	0,156	0,180	0,220	0,251
	<b>265</b>	0,060	0,087	0,111	0,133	0,153	0,187	0,213
	<b>220</b>	0,050	0,072	0,091	0,109	0,126	0,154	0,176
	<b>120</b>	0,028	0,041	0,052	0,063	0,072	0,088	0,100
	<b>195</b>	0,050	0,072	0,091	0,109	0,126	0,154	0,176
	<b>180</b>	0,043	0,061	0,078	0,094	0,108	0,132	0,151
	<b>635</b>	0,053	0,076	0,097	0,116	0,133	0,162	0,186
	<b>420</b>	0,055	0,079	0,101	0,121	0,140	0,171	0,195
	<b>335</b>	0,058	0,083	0,106	0,127	0,146	0,179	0,204
	<b>245</b>	0,063	0,091	0,116	0,139	0,160	0,195	0,223
	<b>245</b>	0,042	0,060	0,077	0,093	0,106	0,130	0,149
	<b>180</b>	0,042	0,060	0,077	0,093	0,106	0,130	0,149
	<b>305</b>	0,026	0,038	0,048	0,058	0,066	0,081	0,093

Die angegebenen Arbeitswerte sind Richtwerte.  
 Die für den jeweiligen Bearbeitungsfall optimalen Daten sollten im Versuch oder während der Bearbeitung ermittelt werden.

# Schnittwertempfehlung für Bohrfräser

Vorschub und Schnittgeschwindigkeit

Nutfräsen

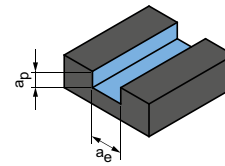

$$a_p = 1 \times D$$

$$a_e = 1 \times D$$

## OptiMill-DrillMill | M5490

MZG*	Werkstoff	Festigkeit/ Härte [N/mm <sup>2</sup> ] [HRC]	Kühlung			v <sub>c</sub> [m/min]	f <sub>z</sub> [mm]								
			MMS/Luft	Trocken	KSS		Fräserdurchmesser [mm]								
							2,00	4,00	6,00	8,00	10,00	12,00	16,00	20,00	
P	P1.1	Bau-, Automaten-, Einsatz- und Vergütungsstähle, unlegiert	< 700	✓	✓	✓	120	0,008	0,014	0,021	0,027	0,032	0,037	0,045	0,051
	P1.2	Bau-, Automaten-, Einsatz- und Vergütungsstähle, unlegiert	< 1.200	✓	✓	✓	100	0,007	0,014	0,019	0,025	0,030	0,034	0,042	0,048
	P2.1	Nitrier-, Einsatz- und Vergütungsstähle, legiert	< 900	✓	✓	✓	110	0,008	0,014	0,021	0,027	0,032	0,037	0,045	0,051
	P2.2	Nitrier-, Einsatz- und Vergütungsstähle, legiert	< 1.400	✓	✓	✓	75	0,006	0,012	0,017	0,022	0,027	0,031	0,037	0,043
	P3.1	Werkzeug-, Wälzlager-, Feder- und Schnellarbeitsstähle**	< 800	✓	✓	✓	70	0,007	0,014	0,020	0,026	0,031	0,035	0,043	0,049
	P3.2	Werkzeug-, Wälzlager-, Feder- und Schnellarbeitsstähle**	< 1.000	✓	✓	✓	65	0,007	0,013	0,019	0,024	0,029	0,034	0,041	0,047
	P3.3	Werkzeug-, Wälzlager-, Feder- und Schnellarbeitsstähle**	< 1.500	✓	✓	✓	60	0,007	0,013	0,018	0,023	0,028	0,032	0,039	0,044
P5	P5.1	Stahlguss				✓	75	0,007	0,014	0,020	0,026	0,031	0,035	0,043	0,049
K	K1.1	Gusseisen mit Lamellengraphit (Grauguss), GJL	< 300	✓	✓	✓	130	0,013	0,024	0,035	0,044	0,053	0,061	0,075	0,085
	K2.1	Gusseisen mit Kugelgraphit, GJS	< 500	✓	✓	✓	120	0,011	0,021	0,029	0,038	0,045	0,052	0,063	0,072
	K2.2	Gusseisen mit Kugelgraphit, GJS	500-800	✓	✓	✓	95	0,009	0,017	0,024	0,031	0,037	0,043	0,052	0,060
	K2.3	Gusseisen mit Kugelgraphit, GJS	> 800	✓	✓	✓	55	0,005	0,010	0,014	0,018	0,021	0,024	0,030	0,034
	K3.1	Gusseisen mit Vermiculargraphit, GJV; Temperguss, GJM	< 500	✓	✓	✓	85	0,009	0,017	0,024	0,031	0,037	0,043	0,052	0,060
	K3.2	Gusseisen mit Vermiculargraphit, GJV; Temperguss, GJM	> 500	✓	✓	✓	80	0,008	0,014	0,021	0,027	0,032	0,037	0,045	0,051
N	N1.1	Aluminium, unlegiert und legiert <3 % Si		✓	✓	✓	460	0,013	0,025	0,035	0,045	0,054	0,062	0,076	0,087
	N1.2	Aluminium, legiert ≤ 7 % Si		✓	✓	✓	305	0,014	0,026	0,037	0,047	0,057	0,065	0,080	0,091
	N1.3	Aluminium, legiert > 7-12 % Si		✓	✓	✓	245	0,014	0,027	0,039	0,050	0,059	0,068	0,084	0,095
	N1.4	Aluminium, legiert > 12 % Si		✓	✓	✓	175	0,015	0,030	0,042	0,054	0,065	0,075	0,091	0,104
	N2.1	Kupfer, unlegiert und niedriglegiert	< 300	✓	✓	✓	175	0,010	0,020	0,028	0,036	0,043	0,050	0,061	0,069
	N2.2	Kupfer, legiert	> 300	✓	✓	✓	130	0,010	0,020	0,028	0,036	0,043	0,050	0,061	0,069
	N2.3	Messing, Bronze, Rotguss	< 1.200	✓	✓	✓	220	0,006	0,012	0,018	0,023	0,027	0,031	0,038	0,043

\* MILLER Zerspanungsgruppen

\*\* Wenn die Legierungsbestandteile Cr, Mo, Ni, V, W in Summe > 8 %, dann die nächst höhere MILLER Zerspanungsgruppe wählen.



**Besäumen**

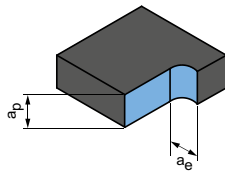

$$a_p = 1,5xD$$

$$a_e = 0,25xD$$

**Besäumen**

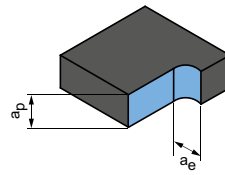

$$a_p = 1,5xD$$

$$a_e = 0,1xD$$

	$v_c$ [m/min]	$f_z$ [mm]								$v_c$ [m/min]	$f_z$ [mm]							
		Fräserdurchmesser [mm]									Fräserdurchmesser [mm]							
		2,00	4,00	6,00	8,00	10,00	12,00	16,00	20,00		2,00	4,00	6,00	8,00	10,00	12,00	16,00	20,00
	<b>215</b>	0,013	0,025	0,035	0,045	0,054	0,062	0,076	0,087	<b>290</b>	0,020	0,039	0,056	0,071	0,085	0,098	0,120	0,137
	<b>175</b>	0,012	0,023	0,033	0,042	0,050	0,058	0,071	0,081	<b>235</b>	0,019	0,036	0,052	0,067	0,080	0,092	0,112	0,128
	<b>195</b>	0,013	0,025	0,035	0,045	0,054	0,062	0,076	0,087	<b>260</b>	0,020	0,039	0,056	0,071	0,085	0,098	0,120	0,137
	<b>135</b>	0,011	0,020	0,029	0,038	0,045	0,052	0,063	0,072	<b>185</b>	0,017	0,032	0,047	0,059	0,071	0,082	0,100	0,114
	<b>125</b>	0,012	0,024	0,034	0,044	0,052	0,060	0,073	0,084	<b>170</b>	0,020	0,038	0,054	0,069	0,083	0,095	0,116	0,133
	<b>115</b>	0,012	0,023	0,032	0,041	0,050	0,057	0,070	0,079	<b>155</b>	0,019	0,036	0,051	0,065	0,078	0,090	0,110	0,126
	<b>105</b>	0,011	0,021	0,031	0,039	0,047	0,054	0,066	0,075	<b>145</b>	0,018	0,034	0,048	0,062	0,074	0,085	0,104	0,119
	<b>130</b>	0,012	0,024	0,034	0,044	0,052	0,060	0,073	0,084	<b>175</b>	0,020	0,038	0,054	0,069	0,083	0,095	0,116	0,133
	<b>265</b>	0,021	0,041	0,059	0,075	0,090	0,103	0,126	0,145	<b>390</b>	0,034	0,065	0,093	0,119	0,142	0,164	0,200	0,228
	<b>245</b>	0,018	0,035	0,050	0,064	0,077	0,088	0,107	0,123	<b>355</b>	0,029	0,055	0,079	0,101	0,121	0,139	0,170	0,194
	<b>200</b>	0,015	0,029	0,041	0,053	0,063	0,072	0,088	0,101	<b>290</b>	0,024	0,045	0,065	0,083	0,100	0,115	0,140	0,160
	<b>110</b>	0,009	0,016	0,024	0,030	0,036	0,041	0,051	0,058	<b>160</b>	0,014	0,026	0,037	0,048	0,057	0,065	0,080	0,091
	<b>175</b>	0,015	0,029	0,041	0,053	0,063	0,072	0,088	0,101	<b>260</b>	0,024	0,045	0,065	0,083	0,100	0,115	0,140	0,160
	<b>165</b>	0,013	0,025	0,035	0,045	0,054	0,062	0,076	0,087	<b>245</b>	0,020	0,039	0,056	0,071	0,085	0,098	0,120	0,137
	<b>705</b>	0,018	0,034	0,049	0,063	0,076	0,087	0,106	0,121	<b>845</b>	0,025	0,048	0,069	0,088	0,105	0,121	0,148	0,169
	<b>470</b>	0,019	0,036	0,052	0,066	0,079	0,091	0,112	0,128	<b>565</b>	0,026	0,050	0,072	0,092	0,111	0,127	0,155	0,178
	<b>375</b>	0,020	0,038	0,054	0,069	0,083	0,096	0,117	0,134	<b>450</b>	0,028	0,053	0,076	0,097	0,116	0,133	0,163	0,186
	<b>270</b>	0,022	0,041	0,059	0,076	0,091	0,104	0,127	0,146	<b>325</b>	0,030	0,057	0,083	0,106	0,126	0,145	0,177	0,203
	<b>270</b>	0,014	0,028	0,040	0,051	0,061	0,070	0,085	0,097	<b>325</b>	0,020	0,038	0,055	0,070	0,084	0,097	0,118	0,135
	<b>205</b>	0,014	0,028	0,040	0,051	0,061	0,070	0,085	0,097	<b>245</b>	0,020	0,038	0,055	0,070	0,084	0,097	0,118	0,135
	<b>340</b>	0,009	0,017	0,025	0,032	0,038	0,043	0,053	0,061	<b>405</b>	0,013	0,024	0,034	0,044	0,053	0,061	0,074	0,085

Die angegebenen Arbeitswerte sind Richtwerte.

Die für den jeweiligen Bearbeitungsfall optimalen Daten sollten im Versuch oder während der Bearbeitung ermittelt werden.

$$hm = fz \cdot \sqrt{\frac{ae}{D}} \text{ [mm]}$$

 $a_p$  $\cos \varphi_s =$  $d$ 

# TECHNISCHER ANHANG

---

Hinweise zu Anwendung und Handhabung.

$$1 - \frac{2 \cdot a_e}{D}$$



59.5  
Antriebsauslastung - Anzeige  
X1 Y1 Z1 C1  
01/07 Service Info  
DATE: 01.01.11 TIME: 10:20 (24.7)  
MEL 4 Betriebsart aktiv  
NC/UKS/4\_1471\_SPM1\_STANDARDPROG/SPM1\_2\_2  
702012 4  
RESET UKS  
Position (mm)  
X 226.533  
Y 33.867  
Z 46.362  
C 0.000  
B 0.000  
G55  
TFS  
T SPM1\_STANDARD D1  
F SPM1\_STANDARD R0.000 L137.750  
S1 Master 0 mm/min 0.0%  
100% 1.00  
Alle G-Funktionen  
Zoom Istwert

T.S.M NPV setzen Nullp. Werkst Werkz. messen Position Planfräsen Schwenken

# TECHNISCHER ANHANG

## Vollbohren

---

Anwendungshinweise .....	
Wechselkopfbohrer TTD-Tritan .....	510
Tiefbohren .....	512
Handhabungshinweise .....	
Schneidplattenbohrer EXD .....	514
Wechselbohrer TTD .....	516
Wechselbohrer TTD-Tritan .....	518

## Fräsen

---

Ermittlung eines Schnittwertes .....	520
Berechnungsbeispiel für Schnittwertkorrekturen .....	522
Begriffserklärung und Formeln .....	524
Trochoides Fräsen .....	526

## Anwendungshinweise Wechselkopfbohrer TTD-Tritan

Der dreischneidige Wechselkopfbohrer TTD-Tritan garantiert an der Schnittstelle eine optimale Drehmomentübertragung bei gleichzeitig hoher Wechsel- und Rundlaufgenauigkeit. Der Wechselkopf lässt sich schnell und prozesssicher wechseln, dabei ist eine falsche Positionierung unmöglich.

Ein passender TORX®-Schlüssel mit Griff liegen dem Werkzeug bei, um den Wechselkopf über die Spezialschraube am Wechselkopfhalter exakt zu spannen.

### Kühlmittelsituation:

Kühlmitteldruck abhängig von der Bohrtiefe: 3xD: 8 bar | 5xD: 12 bar | 8xD: 25 bar



### Maximaler Ein- und Austrittswinkel:

Beim Anbohren und beim Austritt an schrägen Flächen  $v_f$  um 50 % reduzieren.

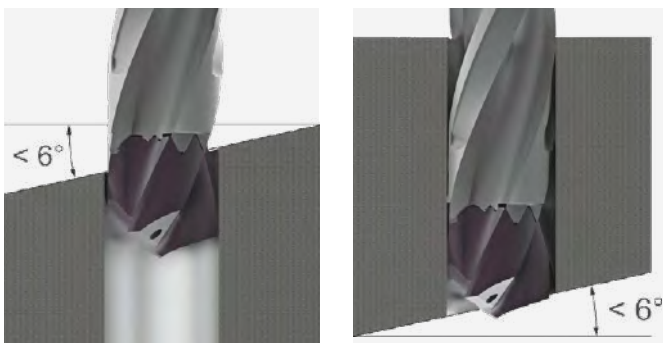

### Durchgangsbohrung:

Beim Bohrungsaustritt wird empfohlen, keine Schnittwertreduzierungen vorzunehmen.

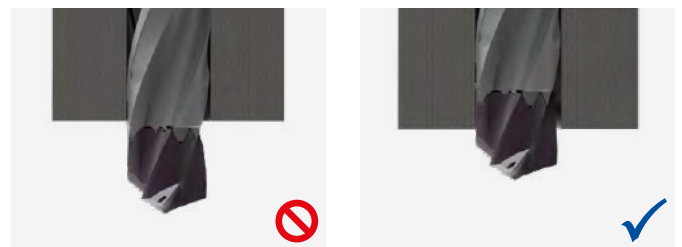

### Rundlaufgenauigkeit:

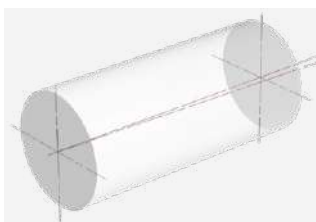

Max. 0,02 mm

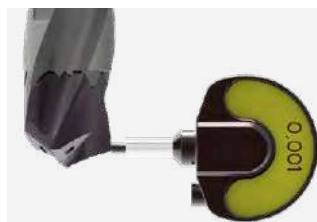

Max. 0,04 mm

**Kein Eilgang beim Rückzug:**

Für die Rückzugsgeschwindigkeit wird der fünffache Wert der Vorschubgeschwindigkeit empfohlen.

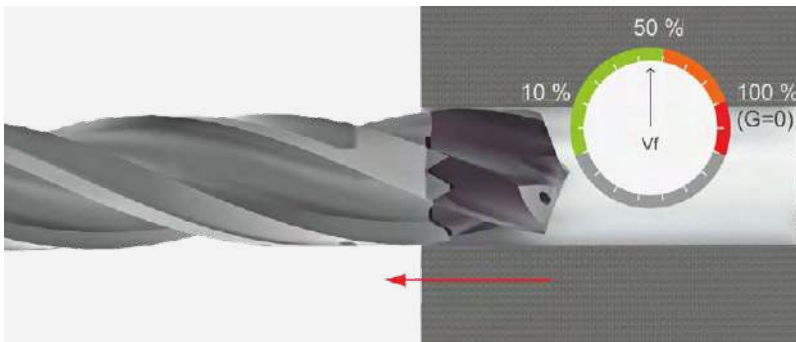

**Bearbeitungssituationen:**



Bohrung außermittig;  
Querschnitte im Eingriff



Bohrung außermittig;  
Querschnitte nicht im Eingriff

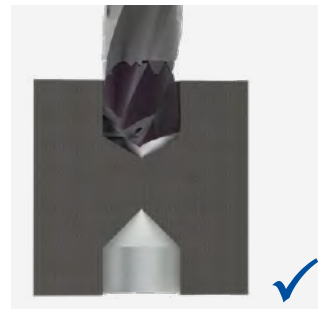

Durchbruch bei Gegenbohrung;  
 $v_f = -50\%$

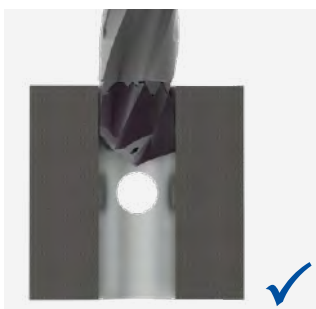

Bohrung mittig und  $\ll D$



Bohrung mittig und  $\approx D$



Bohrung mittig und  $\gg D$

# Tiefbohren

Für MEGA-Deep-Drill | MEGA-Deep-Drill-Alu

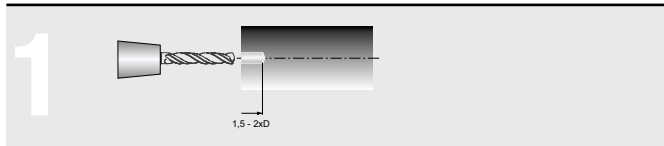

### Pilotbohrung setzen

- Empfehlung für Pilotbohrer siehe folgende Seite (oder 0,01-0,02 mm größer als der Tiefbohrerdurchmesser)
- Tiefe der Pilotbohrung zwischen 1,5 und 2xD

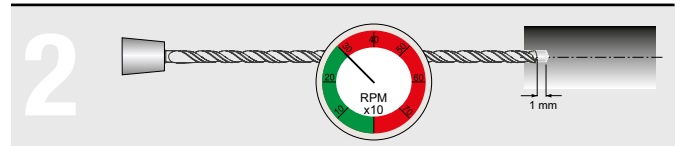

### MEGA-Deep-Drill - Einfahren in die Pilotbohrung

- Einfahren mit max. 300 min<sup>-1</sup> und v<sub>f</sub> = 1000 mm/min
- Ohne Kühlmittel - bis 1 mm vor dem Bohrungsgrund der Pilotbohrung
- Kühlmittel einschalten

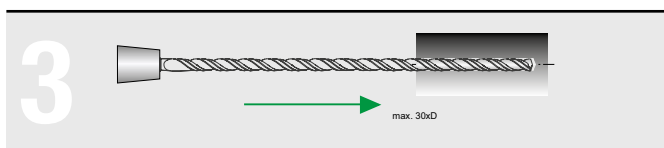

### Bohren mit MEGA-Deep-Drill

- Schnittgeschwindigkeit (v<sub>c</sub>) und Vorschübe (f) gemäß Tabelle (siehe Seite 294). Bohren ohne Entspanzyklen

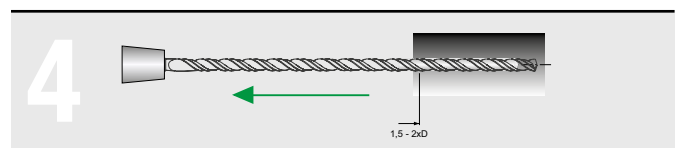

### MEGA-Deep-Drill - Zurückfahren

- Zurückfahren mit aktueller Drehzahl und doppeltem Vorschub (= 2 x v<sub>f</sub>) bis 1,5 – 2xD zum Ende der Bohrung

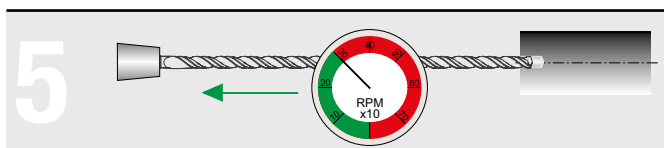

### MEGA-Deep-Drill - Ausfahren aus der Bohrung

- Kühlmittel ausschalten
- Ausfahren mit max. 300 min<sup>-1</sup> und v<sub>f</sub> = 1000 mm/min

### Anwendungshinweise für Durchmesser ≤3 mm:

- Wahl eines für Kleinwerkzeuge geeigneten Kühlmitteltyps für optimale Kühl- und Schmierung
- Effektive Filtration des Kühlmediums, um ein Verstopfen der Kühlkanäle zu vermeiden
- Wahl eines geeigneten Bohrzyklus (ggf. Bohren mit Entspanzyklen)

# Erforderlicher Kühlmitteldruck

Für MEGA-Deep-Drill | MEGA-Deep-Drill-Alu

	ø 3 - 5 mm	ø 5 - 8 mm	ø 8 - 12 mm	ø 12 - 16 mm
IK	60 bar	40 bar	30 bar	25 bar
MMS	12 bar	10 bar	9 bar	8 bar

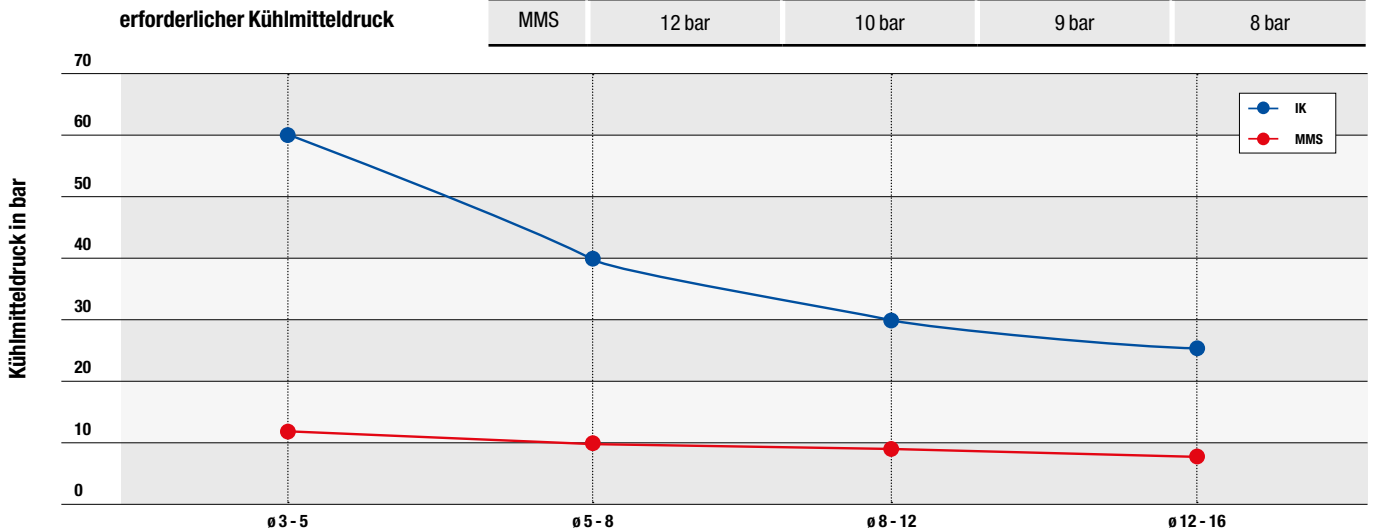



# Tiefbohren 15xD - 30xD in zwei Schritten:

Tiefbohren 15xD - 30xD mit MEGA-Deep-Drill (M21xx) bzw. MEGA-Deep-Drill-Alu (M28xx)

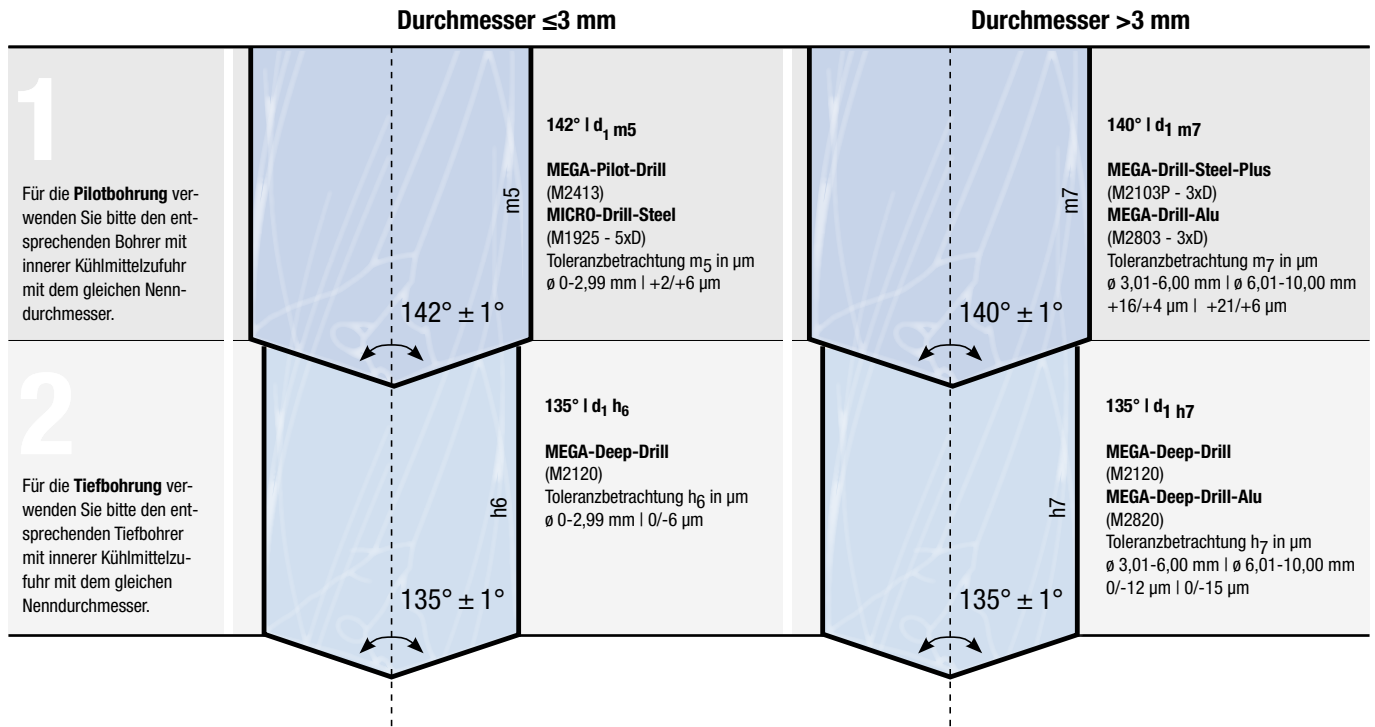

# Tiefbohren 40xD in drei Schritten:

Tiefbohren 40xD mit MEGA-Deep-Drill (M2140) bzw. MEGA-Deep-Drill-Alu (M2840)

Optimal ausgelegt für eine prozesssichere Bearbeitung.

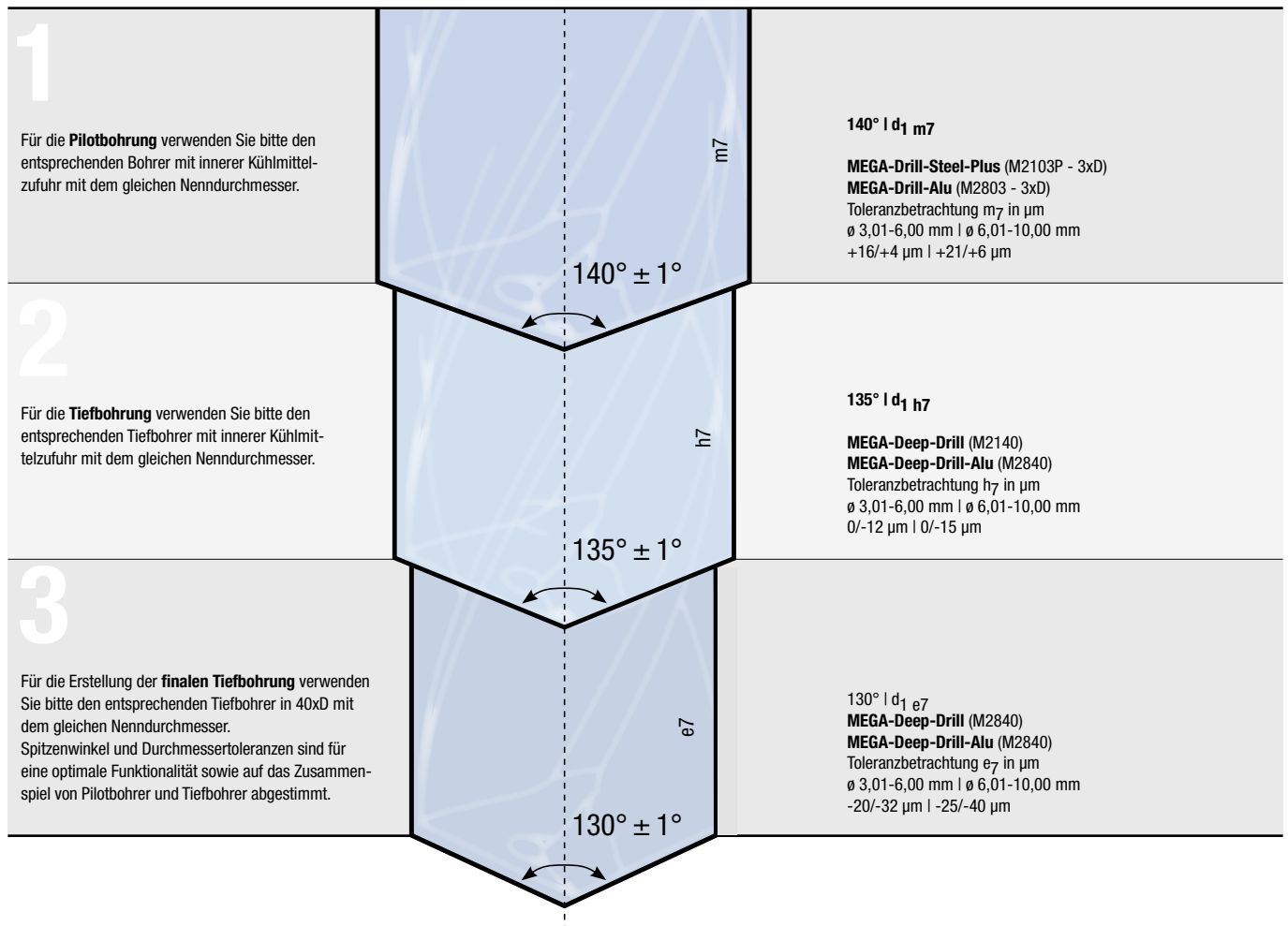

# Handhabungshinweise für Schneidplattenbohrer EXD

Einfaches Wechseln und Einstellen der EXD-Schneiden

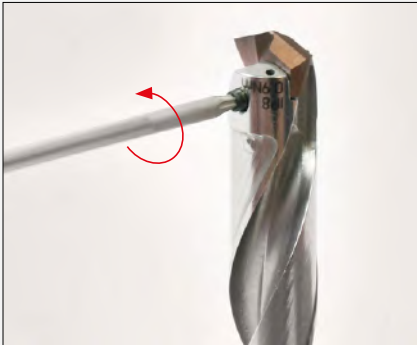

1. Lösen Sie die Spezialspannschraube mit Hilfe des mitgelieferten TORX® PLUS-Schlüssels, indem Sie gegen den Uhrzeigersinn drehen.



2. Entnehmen Sie die Schneidplatte aus dem Plattensitz.



3. Reinigen Sie den Plattensitz mit Druckluft.

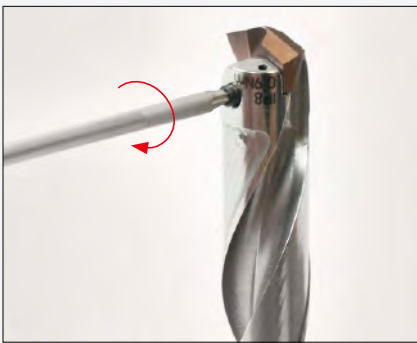

4. Setzen Sie die neue Schneidplatte in den Plattensitz. Ziehen Sie die Spezialspannschraube mit Hilfe des mitgelieferten TORX® PLUS-Schlüssels im Uhrzeigersinn handfest an.



5. Ziehen Sie die Spezialspannschraube mit dem vorgegebenen Anzugsdrehmoment an.

## HINWEISE

- Verwenden Sie ausschließlich die Originalschrauben!
- Spätestens beim 5. Bohrkopfwechsel muss die Spezialspannschraube ausgetauscht werden
- Auf dem Werkzeug ist das gültige Anzugsdrehmoment eingraviert

## Ergebnis:

Die Schneidplatte ist nun vollständig gewechselt und das Werkzeug kann eingesetzt werden.



# Notizen

# Handhabungshinweise Wechselkopfbohrer TTD

Hinweise für die Praxis

## PILOTIEREN

- Ab Bohrtiefen von 8xD ist eine Pilotbohrung zu empfehlen
- Beim Wechselbohrkopf Typ 02 ist eine Pilotbohrung ab einer Bohrtiefe von 5xD zu empfehlen
- Bei einer Pilotbohrung mit dem Wechselbohrkopf Typ 02 ist eine Reduzierung des angegebenen Vorschubs um 50 % zu empfehlen
- Bei einer Pilotbohrung mit den Wechselbohrköpfen Typ 01 und Typ 03 können die empfohlenen Arbeitswerte verwendet werden
- Das Einfahren in die Pilotbohrung erfolgt mit gleicher Bohrkopfgeometrie und reduzierten Arbeitswerten (Empfehlung:  $v_c = 50\%$  und circa  $f = 50\%$ ) bis 1 mm vor dem Bohrungsgrund
- Das Bohren nach dem Pilotieren erfolgt dann mit den empfohlenen Arbeitswerten (siehe Seiten 240-243)

## HINWEISE ZUM BOHREN MIT 12xD-HALTER

- Bei einer Bohrtiefe von 12xD ist eine Pilotbohrung notwendig
- Kühlmitteldruck muss mindestens 40 bar entsprechen
- Bei der Bearbeitung von Stahlwerkstoffen kann Entspannen notwendig sein
- Bei angetriebenem Werkzeug ist ein Einsatz auf der Drehmaschine möglich
- Eine Erhöhung der Schnittgeschwindigkeit um 30 % gegenüber dem Standardwert ist zu empfehlen

## Stehendes Werkzeug

Bei stehendem Werkzeug Spanraumauslauf waagrecht positionieren, damit kein Spänestau entsteht.

## Kühlmittelsituation

Kühlmitteldruck abhängig von der Bohrtiefe:

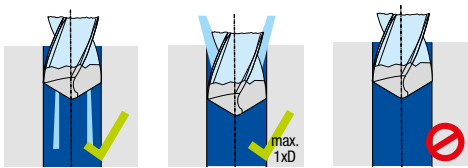

1xD: 8 bar | 3xD: 8 bar | 5xD: 12 bar | 8xD: 25 bar | 12xD: 40 bar

## Durchgangsbohrung

Beim Bohrungsausritt wird empfohlen, keine Schnittwertreduzierung vorzunehmen.

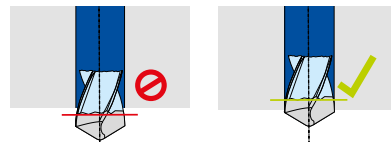

## Rundlaufgenauigkeit

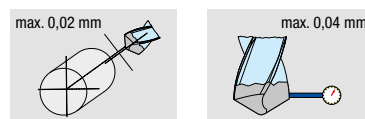

## Max. Ein- und Austrittswinkel

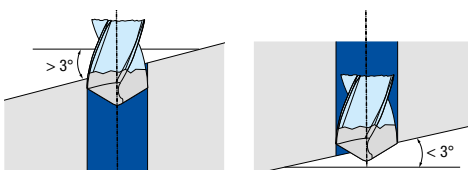

### Kein Eilgang beim Rückzug

Für die Rückzugsgeschwindigkeit wird der 5-fache Wert der Vorschubgeschwindigkeit empfohlen.

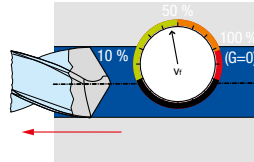

### Bearbeitungssituationen

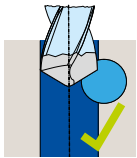

Bohrung außermittig  
Querschnitt im Eingriff

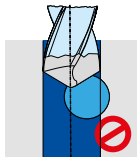

Bohrung außermittig  
Querschnitt nicht im Eingriff

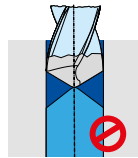

Durchbruch bei  
Gegenbohrung

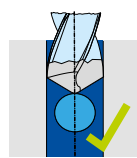

Bohrung mittig  
und  $< D$

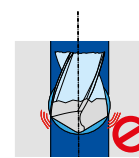

Bohrung mittig  
und = D

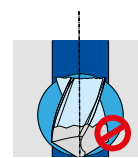

Bohrung mittig  
und  $>> D$

## Montage

### Bohrkopf lösen

1. Prüfen Sie bei jedem Bohrkopfwechsel die Spannschraube auf Schwergängigkeit. Lässt sich die Spannschraube leicht lösen, muss die Spannschraube ausgetauscht werden. Verwenden Sie ausschließlich die Originalspannschrauben!



2. Öffnen Sie die Spannschraube mit Hilfe des mitgelieferten Sechskant-Schraubenschlüssels.



3. Ziehen Sie den Bohrkopf aus der Verzahnung.

#### Hinweis:

Spätestens beim 8. Bohrkopfwechsel muss die Spannschraube ausgetauscht werden.

### Bohrkopf spannen



1. Säubern Sie die TTS-Schnittstelle des Halters mit einer Bürste.



2. Stecken Sie den neuen Bohrkopf auf den Halter.
3. Ziehen Sie die Spannschraube im Uhrzeigersinn handfest an.

#### Hinweis:

Achten Sie darauf, dass die Positionierhilfe des Bohrkopfes mit der Positionierhilfe des Halters in Eingriff ist und dass Spannut und Verzahnung von Bohrkopf und Halter übereinstimmen.

# Handhabungshinweise Wechselkopfbohrer TTD-Tritan

## Werkzeugmontage

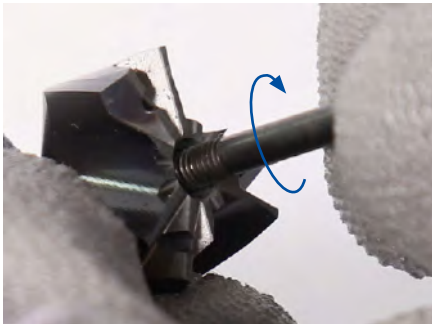

### 1. Spezialspannschraube einsetzen und eindrehen

Die Spezialspannschraube mit der kleinen Gewindegewinde nach vorne in die Bohrung des Wechselbohrkopfs einsetzen. Anschließend die Spezialspannschraube im Uhrzeigersinn bis zum Anschlag eindrehen.



### 2. Reinigen mit Druckluft

Den Wechselkopfhalter und Wechselbohrkopf mit Druckluft reinigen.

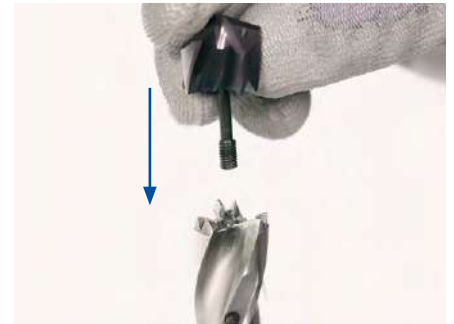

### 3. Wechselbohrkopf aufstecken

Wechselbohrkopf auf Wechselkopfhalter stecken.

### Hinweis:

Die Spezialspannschraube ist bei Lieferzustand bereits am Wechselbohrkopf montiert. Im gelösten Zustand lässt sich die Spezialspannschraube durch Eindrehen wieder am Wechselbohrkopf montieren.

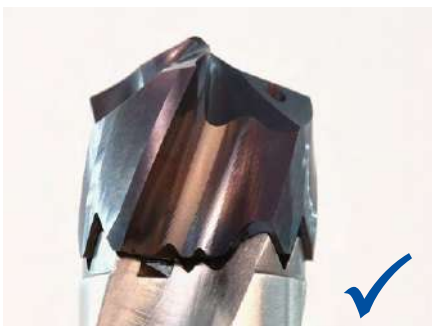

### 4. Positionierung des Bohrkopfs überprüfen

Überprüfen, ob Spann- und Verzahnung von Wechselbohrkopf und Wechselkopfhalter übereinstimmen.

Bei Nichtübereinstimmung, den Wechselbohrkopf so lange drehen, bis Spann- und Verzahnung übereinstimmen.

### Ergebnis:

Spann- und Verzahnung stimmen überein (links) | stimmen nicht überein (rechts)

- 1 Griff für TORX®-Schlüssel
- 2 Wechselkopfhalter TTS
- 3 TORX®-Schlüssel
- 4 Wechselbohrkopf mit Spezialschraube



5. **Spezialschraube bis zum Anschlag anziehen**  
Den Wechselbohrkopf leicht an den Wechselkopfhalter gedrückt halten, damit er seine aufgesteckte Position beibehält. Anschließend den TORX®-Schlüssel in die zentrale Bohrung des Wechselkopfhalters schieben, bis hin zur Gewindebohrung der Spezialschraube. Dann die Spezialschraube mit dem TORX®-Schlüssel gegen den Uhrzeigersinn bis zum Anschlag handfest anziehen.



6. **Spezialschraube mit Anzugsdrehmoment anziehen**

Mit einem passenden Drehmomentschlüssel mit Innensechskant-Bit in Kombination mit dem TORX®-Schlüssel und dem vorgegebenen Anzugsdrehmoment die Spezialschraube anziehen.

**Hinweis:**

Das vorgegebene Anzugsdrehmoment der Spezialschraube steht an der Unterseite des Wechselkopfhalters.

**Ergebnis:**

Die Spezialschraube ist mit dem vorgegebenen Anzugsdrehmoment angezogen und der Wechselbohrkopf ist mit dem Wechselkopfhalter fest verbunden. Der Montagevorgang ist abgeschlossen.

**Lieferumfang:**

- 1 Griff für TORX®-Schlüssel
- 2 Wechselkopfhalter TTS
- 3 TORX®-Schlüssel

**Anzugsdrehmomente der Spezialschraube**

Durchmesserbereich [mm]	Gewinde Wechselkopfhalter	TORX®-Größe	Zulässiges übertragbares Anzugsdrehmoment [Nm]
12,00 - 13,99	M3 x 0,5	T6	0,40
14,00 - 17,49	M3,5 x 0,6	T7	0,70
17,50 - 19,49	M4 x 0,7	T8	1,30
19,50 - 24,49	M5 x 0,8	T10	2,00
24,50 - 28,49	M6 x 1,0	T15	3,10
28,50 - 32,49	M6 x 1,0	T15	5,60

# Ermittlung eines Schnittwertes

## Begriffserklärungen

<b>Schnitttiefe</b>	$a_p = [\text{mm}]$	<b>Vorschub pro Zahn</b>	$f_z = \left[ \frac{\text{mm}}{\text{Zahn}} \right]$
<b>Eingriffsbreite</b>	$a_e = [\text{mm}]$	<b>Schnittgeschwindigkeit</b>	$v_c = \left[ \frac{\text{m}}{\text{min}} \right]$
<b>Korrekturfaktor Arbeitstiefe</b>	$k_{AT}$	<b>Korrekturfaktor Konuswinkel</b>	$k_{KW}$

## Berechnungsformeln

<b>Drehzahl</b>	$n = [\text{min}^{-1}]$	$n = \frac{v_c \cdot 1000}{\pi \cdot d_1}$
<b>Vorschubgeschwindigkeit</b>	$v_f = \left[ \frac{\text{mm}}{\text{min}} \right]$	$v_f = f_z \cdot z \cdot n$
<b>Korrektur Schnitttiefe</b>	$a_p \text{ kor.} = [\text{mm}]$	$a_p \text{ kor.} = a_p \cdot k_{AT}$
<b>Korrektur Drehzahl</b>	$n \text{ kor.} = [\text{min}^{-1}]$	$n \text{ kor.} = n \cdot k_{AT} \cdot k_{KW}$
<b>Korrektur Vorschubgeschwindigkeit</b>	$v_f \text{ kor.} = \left[ \frac{\text{mm}}{\text{min}} \right]$	$v_f \text{ kor.} = v_f \cdot k_{AT} \cdot k_{KW}$
<b>Theoretische Rautiefe</b>	$R_{th} = [\mu\text{m}]$	$R_{th} = R - \sqrt{R^2 - a_e^2/4}$
<b>Eingriffsbreite</b>	$a_e = [\text{mm}]$	$a_e = 2 \cdot \sqrt{R_{th} \cdot ((R \cdot 2) - R_{th})}$

## Ermittlung der Schnittwerte

1. Wählen Sie Ihren Werkstoff gemäß der MZG (MILLER Zerspanungsgruppen, siehe Klappseite am Umschlag)
2. Abhängig vom Werkzeugdurchmesser können Sie die Empfehlung für  $a_p$ ,  $a_e$ ,  $v_c$  und  $f_z$  aus der Schnittwerttabelle entnehmen. Diese Werte sind für Werkzeuge mit einer Arbeitstiefe von  $\leq 3xD$  und einem Konuswinkel von  $0^\circ$  gültig.
3. Abhängig von Arbeitstiefe und Konuswinkel sind die Korrekturfaktoren für Arbeitstiefe  $k_{AT}$  und Konuswinkel  $k_{KW}$  unterhalb der Schnittwerttabelle zu berücksichtigen. Beachten Sie hierzu die Berechnungsformeln.



Theoretische Rautiefe  $R_{th}$

		$a_e$ [mm]														
		0,01	0,02	0,03	0,04	0,05	0,06	0,075	0,08	0,1	0,15	0,2	0,25	0,3	0,4	0,5
R [mm]	0,02	0,64	2,68	6,77												
	0,05	0,25	1,01	2,30	4,17	6,70	10,00	16,93								
	0,10	0,13	0,50	1,13	2,02	3,18	4,61	7,30	8,35	13,40						
	0,15	0,08	0,33	0,75	1,34	2,10	3,03	4,76	5,43	8,58						
	0,20	0,06	0,25	0,56	1,00	1,57	2,26	3,55	4,04	6,35	14,60					
	0,25	0,05	0,20	0,45	0,80	1,25	1,81	2,83	3,22	5,05	11,52					
	0,30	0,04	0,17	0,38	0,67	1,04	1,50	2,35	2,68	4,20	9,53	17,16				
	0,40	0,03	0,13	0,28	0,50	0,78	1,13	1,76	2,01	3,14	7,09	12,70				
	0,50	0,03	0,10	0,23	0,40	0,63	0,90	1,41	1,60	2,51	5,66	10,10	15,88			
	0,75	0,02	0,07	0,15	0,27	0,42	0,60	0,94	1,07	1,67	3,76	6,70	10,49	15,15		
	0,90	0,01	0,06	0,13	0,22	0,35	0,50	0,78	0,89	1,39	3,13	5,57	8,72	12,59		
	1,00	0,01	0,05	0,11	0,20	0,31	0,45	0,70	0,80	1,25	2,82	5,01	7,84	11,31		
	1,25	0,01	0,04	0,09	0,16	0,25	0,36	0,56	0,64	1,00	2,25	4,01	6,27	9,03	16,10	
	1,50	0,01	0,03	0,08	0,13	0,21	0,30	0,47	0,53	0,83	1,88	3,34	5,22	7,52	13,39	
	2,00	0,01	0,03	0,06	0,10	0,16	0,23	0,35	0,40	0,63	1,41	2,50	3,91	5,63	10,03	15,69
	2,50	0,01	0,02	0,05	0,08	0,13	0,18	0,28	0,32	0,50	1,13	2,00	3,13	4,50	8,01	12,53
	3,00	0,00	0,02	0,04	0,07	0,10	0,15	0,23	0,27	0,42	0,94	1,67	2,61	3,75	6,67	10,43
4,00	0,00	0,01	0,03	0,05	0,08	0,11	0,18	0,20	0,31	0,70	1,25	1,95	2,81	5,00	7,82	
5,00	0,00	0,01	0,02	0,04	0,06	0,09	0,14	0,16	0,25	0,56	1,00	1,56	2,25	4,00	6,25	
6,00	0,00	0,01	0,02	0,03	0,05	0,08	0,12	0,13	0,21	0,47	0,83	1,30	1,88	3,33	5,21	
8,00	0,00	0,01	0,01	0,03	0,04	0,06	0,09	0,10	0,16	0,35	0,63	0,98	1,41	2,50	3,91	
10,00	0,00	0,01	0,01	0,02	0,03	0,05	0,07	0,08	0,13	0,28	0,50	0,78	1,13	2,00	3,13	

Theoretische Rautiefe  $R_{th}$  [ $\mu\text{m}$ ]

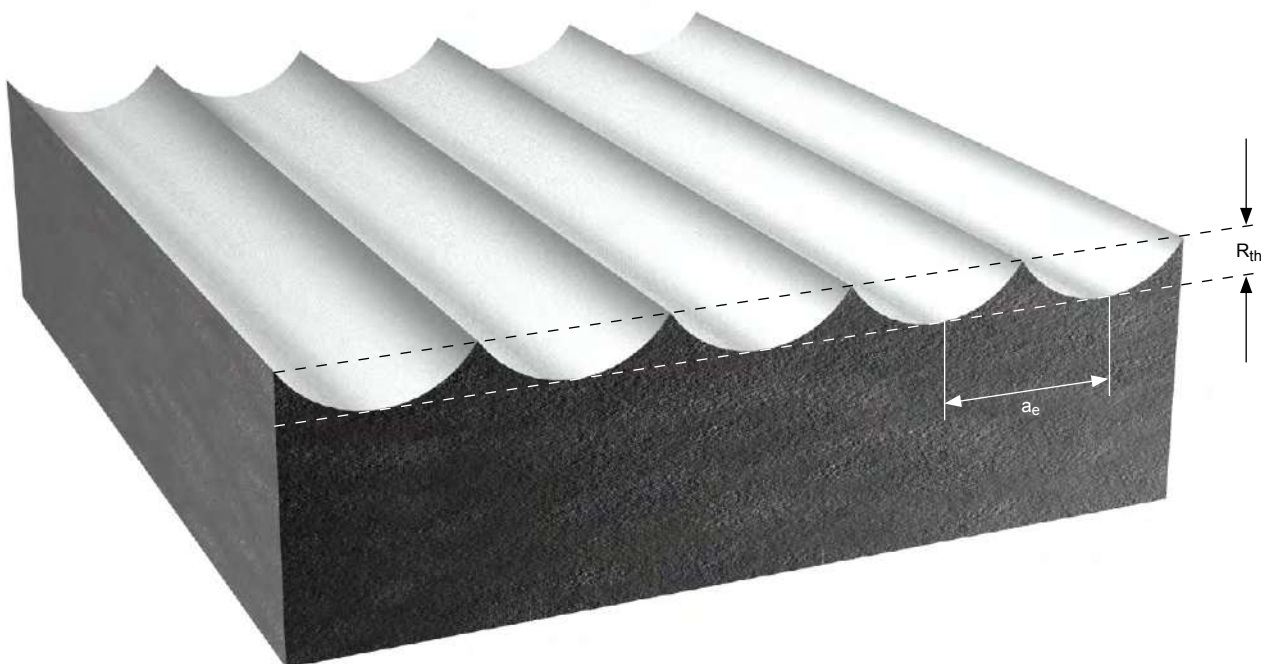

# Berechnungsbeispiele für Schnittwertempfehlung

Schnittwerte unter Berücksichtigung der Korrekturfaktoren

## OptiMill-TBN/-TCR:

Werkzeug: TBN105-120-0500-5000B100-HP801  
 Anwendung: Schruppen  
 Werkzeugdurchmesser: 10 mm  
 Arbeitstiefe AT:  $\leq 10xD$   
 Konuswinkel  $\varphi$ :  $1^\circ$   
 Formschräge:  $1^\circ$   
 Werkstoff: S235JRC



		$a_p$ [mm]	$a_e$ [mm]	$v_c$ [m/min]	$f_z$ [mm]
P1.1	Bau-, Automaten-, Einsatz- und Vergütungsstähle, unlegiert	1 0,05xD	< 0,25xD	300	0,200

### 2 Korrekturfaktor Arbeitstiefe - $k_{AT}$

AT	$k_{AT}$		
	$a_p$	n	$v_f$
$\leq 10xD$	0,50	0,70	0,70

### 3 Korrekturfaktor Konuswinkel - $k_{KW}$

$\varphi$ [°]	$k_{KW}$		
	$a_p$	n	$v_f$
1	1,02	1,02	1,02

## Berechnung

## Berechnungsformel

## Beispielrechnung

<b>Korrektur Schnitttiefe</b>	$a_p \text{ kor.} = a_p \cdot k_{AT} = [0,05 \times d_i] \cdot k_{AT}$	1 2 $0,05 \cdot 10 \cdot 0,50 = 0,25 \text{ mm}$
<b>Korrektur Drehzahl</b>	$n \text{ kor.} = n \cdot k_{AT} \cdot k_{KW} = \left[ \frac{300 \cdot 1000}{\pi \cdot 10} \right] \cdot k_{AT} \cdot k_{KW}$	2 3 $9554 \text{ min}^{-1} \cdot 0,70 \cdot 1,02 = 6821 \text{ min}^{-1}$
<b>Korrektur Vorschubgeschwindigkeit</b>	$v_f \text{ kor.} = v_f \cdot k_{AT} \cdot k_{KW} = [0,2 \cdot 4 \cdot 9554] \cdot k_{AT} \cdot k_{KW}$	2 3 $7643 \frac{\text{mm}}{\text{min}} \cdot 0,70 \cdot 1,02 = 5457 \frac{\text{mm}}{\text{min}}$

**Uni-HPC-Plus:**

Werkzeug: M3194P-1000BL  
 Anwendung: Schruppen  
 Werkzeugdurchmesser: 10 mm  
 Ausführung: extra lang  
 Werkstoff: S235JRC



	$v_c$ [m/min]	$f_z$ [mm]
P1.1 Bau-, Automaten-, Einsatz- und Vergütungsstähle, unlegiert	<b>1</b> 355	<b>2</b> 0,090

**3 Korrekturfaktor Werkzeuglänge -  $k_{WL}$**

Länge	Korrekturfaktoren	
	$f_z$	$v_c$
extra lang	0,6	0,7

Berechnung	Berechnungsformel	Beispielrechnung
<b>Korrektur Schnittgeschwindigkeit</b>	$v_c \text{ kor.} = v_c \cdot k_{WL}$	<b>1</b> <b>3</b> $355 \frac{m}{min} \cdot 0,60 = 213 \frac{m}{min}$
<b>Korrektur Vorschub pro Zahn</b>	$f_z \text{ kor.} = f_z \cdot k_{WL}$	<b>2</b> <b>3</b> $0,090 \cdot 0,60 = 0,054 f_z$

## Begriffserklärung und Formeln

### Formeln

<b>Vorschub pro Umdrehung</b>	$f_u = \left[ \frac{\text{mm}}{U} \right]$	$f_u = z \cdot f_z$	
<b>Vorschub pro Zahn</b>	$f_z = \left[ \frac{\text{mm}}{\text{Zahn}} \right]$	$f_z = \frac{v_f}{n \cdot z}$	

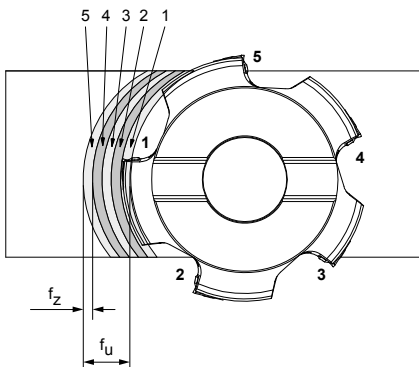
 **$f_z$  beim Stirnfräsen**

<b>Drehzahl</b>	$n = [\text{min}^{-1}]$	$n = \frac{v_c \cdot 1000}{\pi \cdot D}$
<b>Mittlere Spandicke</b>	$h_m = [\text{mm}]$	$h_m = \sin \kappa \cdot f_z \cdot \sqrt{\frac{a_e}{D}}$
<b>Schnittgeschwindigkeit</b>	$v_c = \left[ \frac{\text{m}}{\text{min}} \right]$	$v_c = \frac{\pi \cdot D_c \cdot n}{1000}$
<b>Vorschubgeschwindigkeit</b>	$v_f = \left[ \frac{\text{mm}}{\text{min}} \right]$	$v_f = f_z \cdot z \cdot n$
<b>Zeitspanvolumen</b>	$Q = \left[ \frac{\text{cm}^3}{\text{min}} \right]$	$Q = \frac{a_e \cdot a_p \cdot v_f}{1000}$

# Trochoides Fräsen – Grundlagen

## Definition

Das trochoide Fräsen ist eine Frässtrategie mit dem Ziel die Prozesskräfte zu senken und gleichzeitig die Zeitspanvolumina zu steigern. Durch eine Überlagerung der Vorschubbewegung mit einer Kreisbewegung des Werkzeugs können die Eingriffsbedingungen positiv beeinflusst werden. Es kommt zu einem zyklischen Materialabtrag mit veränderlichen und auf den Werkzeugeinsatz abstimmbaren Eingriffsbedingungen sowie variablen Spanungsbreiten entlang der Kreisbahn des Werkzeugs.



## Beispiel Vollnutfräsen

### Konventionelles Fräsen

Bei einer Schruppbearbeitung im Vollschnitt sind die Eingriffsbedingungen des Fräasers auf einen Umschlingungswinkel von  $180^\circ$  festgelegt.

Dieser führt neben der Erzeugung langer Späne aufgrund des langen Zahneingriffs zu einer vergleichsweise hohen thermischen Belastung des Werkzeugs. Der daraus resultierende große Spanungsquerschnitt hat wiederum hohe Zerspänkkräfte zur Folge, wodurch prozessstabile Zustelltiefen, Vorschübe und Schnittgeschwindigkeiten limitiert sind.

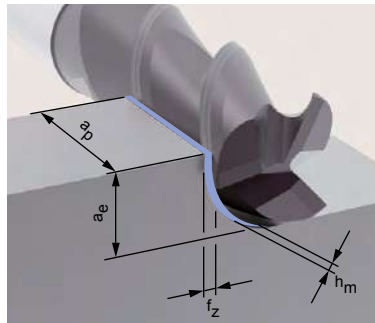
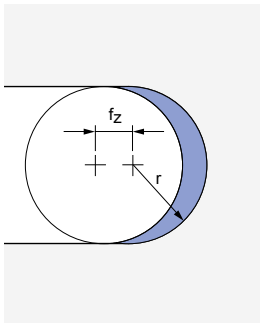

$a_p$ : klein (Schnitttiefe  $\sim 1 \times D$ )  
 $a_e$ : groß ( $1 \times D$ )  
 $f_z$ : klein  
 $v_c$ : niedrig

### Trochoides Fräsen

Die spezifische Kinematik des trochoiden Fräsens ermöglicht es, aufgrund einer Überlagerung der Vorschubbewegung mit einer Kreisbewegung des Werkzeugs, die Eingriffsbedingungen positiv zu beeinflussen. Der Eingriffswinkel ist entsprechend gering.

Dieser Technologieansatz hat zur Folge, dass eine verringerte Spanungsbreite und Schnittlänge zu deutlich reduzierten Prozesskräften führen. Hierdurch ist es wiederum möglich, größere Schnitttiefen zu realisieren.

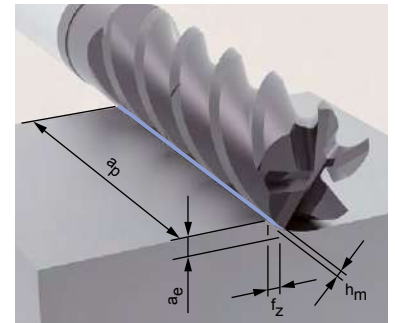
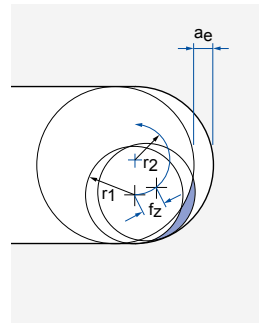

$a_p$ : groß (Volle Ausnutzung der Schneidenlänge möglich)  
 $a_e$ : klein  
 $f_z$ : groß  
 $v_c$ : hoch

# Trochoides Fräsen – im Detail

## Trochoides Fräsen - Kreisbahn

Für den Fall einer Kreisbahn mit konstantem Radius variieren die Umschlingungswinkel an der eingreifenden Werkzeugschneide je nach absoluter radialer Zustellung innerhalb einer Umdrehung.

- Eingriffsbedingungen ändern sich ständig
- optimaler Arbeitsbereich des Fräasers
- begrenzt auf einen kleinen Bereich
- geringes Spanvolumen
- erhöhte Schwingungsneigung
- erhöhter Werkzeugverschleiß

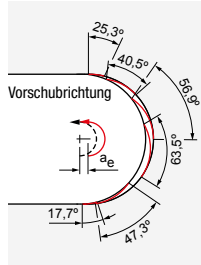

Umschlingung in Abhängigkeit der Bahnposition - Kreisbahn

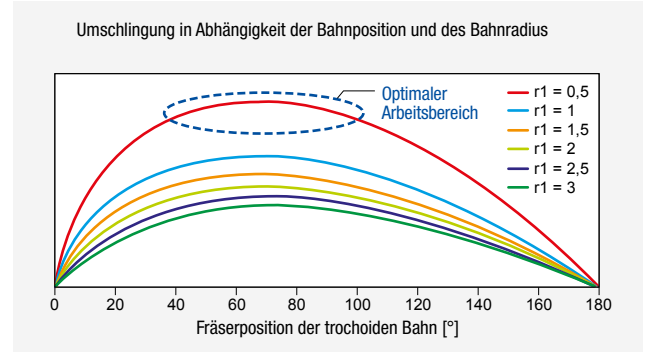

## Trochoides Fräsen - Optimierte Bahnkurve

Durch eine angepasste Bahnbewegung des Werkzeugs können die Eingriffsverhältnisse des Fräasers in jedem Punkt der Bahn über nahezu die gesamte Bearbeitung konstant gehalten werden. Somit kann der Fräsprozess stets am Optimum betrieben werden. Innerhalb einer Bahn wird der Vorschub so angepasst, dass die Spanmittendicke konstant bleibt.

- konstante Eingriffsbedingungen
- konstantes Kraftniveau
- geringerer Werkzeugverschleiß
- maximales Zeitspanvolumen

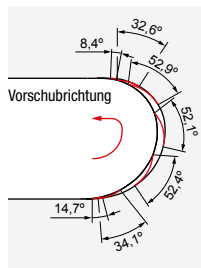

Umschlingung in Abhängigkeit der Bahnposition - Optimierte Bahnkurve

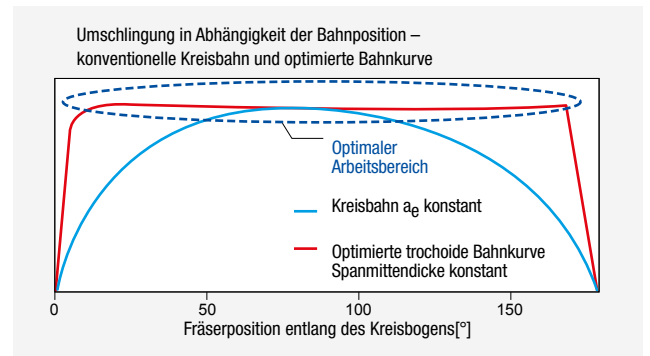

## Vorschubbewegung - Optimierter Luftschnitt

Für eine ganzheitliche Prozessoptimierung müssen neben der Werkzeugbahn während des Eingriffs auch die Verfahrbewegungen im Luftschnitt betrachtet werden. Ziel ist es, nach dem Austritt des Fräasers aus dem Material eine möglichst rasche Bewegung zum nächsten Eintrittspunkt zu realisieren. Da die Ausführung einer Kreisbahn an dieser Stelle nicht von Vorteil ist, wird in Abhängigkeit der Dynamik der Maschine ein möglichst direkter Anfahrweg gewählt.

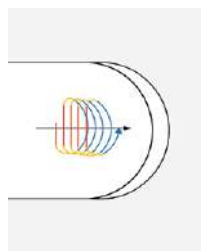

■ Vorschub  
■ Rampe  
■ Eilgang

### HINWEIS

- Das trochoides Fräsen setzt neben einem modernen CAM-System oder einer modernen Maschinensteuerung auch ein möglichst dynamisches Bearbeitungszentrum voraus.
- Die volle Leistungsfähigkeit wird durch die Verwendung von OptiMill-Fräsern der Trochoid-Baureihe erreicht.

## Spanmittendicke $h_m$ und Eingriffswinkel $\varphi$

Eingriffswinkel	$\varphi = [^\circ]$	$\cos \varphi = 1 - \frac{2 \cdot a_e}{D}$	Ist abhängig vom Eingriffsverhältnis $a_e/D$ und wird je nach Werkstoff begrenzt.
Spanmittendicke	$h_m = [mm]$	$h_m = f_z \cdot \sqrt{\frac{a_e}{D}}$	Wird beim trochoiden Fräsen durch dynamische Vorschübe nahezu konstant gehalten. Die Spanmittendicke wird bei $\varphi/2$ gemessen.
Vorschub pro Zahn	$f_z = \frac{[mm]}{\text{Zahn}}$		Eingeschränkte Variable, wird während der Bearbeitung durch CAM-System angepasst.
Eingriffsbreite	$a_e = [mm]$		Wird ständig von der CAM-Software neu berechnet und begrenzt den Eingriffswinkel $\varphi$ .
Werkzeugdurchmesser	$D = [mm]$		

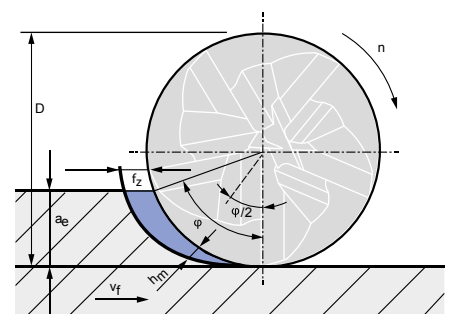





# MILLER Zerspanungsgruppen

Zerspanungsgruppe	Werkstoff	Festigkeit/Härte [N/mm <sup>2</sup> ] [HRC]	Häufig bearbeitete Werkstoffe	
P	P1.1	Bau-, Automaten-, Einsatz- und Vergütungsstähle, unlegiert	< 700 N/mm <sup>2</sup>	1.0122 (S235/St 37), 1.0401 (C15), 1.0503 (C45), 1.0570 (S355/St 52), 1.1213 (Cf53)
	P1.2	Bau-, Automaten-, Einsatz- und Vergütungsstähle, unlegiert	< 1.200 N/mm <sup>2</sup>	1.1249 (Cf70)
	P2.1	Nitrier-, Einsatz- und Vergütungsstähle, legiert	< 900 N/mm <sup>2</sup>	1.7131 (16MnCr5)
	P2.2	Nitrier-, Einsatz- und Vergütungsstähle, legiert	< 1.400 N/mm <sup>2</sup>	1.7227 (42CrMoS4)
	P3.1	Werkzeug-, Wälzlager-, Feder- und Schnellarbeitsstähle*	< 800 N/mm <sup>2</sup>	1.2343 (X37CrMoV5-1), 1.2762 (75CrMoNiW6-7)
	P3.2	Werkzeug-, Wälzlager-, Feder- und Schnellarbeitsstähle*	< 1.000 N/mm <sup>2</sup>	1.2367 (X38CrMoV5-3), 1.2713 (55NiCrMoV6)
	P3.3	Werkzeug-, Wälzlager-, Feder- und Schnellarbeitsstähle*	< 1.500 N/mm <sup>2</sup>	1.2379 (X153CrMoV12) 1.2738 (40CrMnNiMo8-6-4)
	P4.1	Rostfreie Stähle, ferritisch und martensitisch		1.4510 (X3CrTi17), 1.4589 (X5CrNiMoTi15-2)
	P5.1	Stahlguss		1.7231 (G42CrMo4)
	P6.1	Rostfreier Stahlguss, ferritisch und martensitisch		
M	M1.1	Rostfreie Stähle, austenitisch	< 700 N/mm <sup>2</sup>	1.4301 (V2A), 1.4571 (V4A)
	M1.2	Rostfreie Stähle, ferritisch/austenitisch (Duplex)	< 1.000 N/mm <sup>2</sup>	1.4362 (Alloy 2304), 1.4501, 1.4662 (LDX 2404)
	M2.1	Rostfreier Stahlguss, austenitisch	< 700 N/mm <sup>2</sup>	
M3.1	Rostfreier Stahlguss, ferritisch/austenitisch (Duplex)	< 1.000 N/mm <sup>2</sup>		
K	K1.1	Gusseisen mit Lamellengraphit (Grauguss), GJL	< 300 N/mm <sup>2</sup>	GJL-250 (GG-25), GJL-260 (GG-26 Cr)
	K2.1	Gusseisen mit Kugelgraphit, GJS	< 500 N/mm <sup>2</sup>	GJS-400 (GGG-40), GJS-450 (GGG-45)
	K2.2	Gusseisen mit Kugelgraphit, GJS	≤ 800 N/mm <sup>2</sup>	GJS-600 (GGG-60), GJS-800-2 (GGG-80), GJS-800-8 (ADI 800)
	K2.3	Gusseisen mit Kugelgraphit, GJS	> 800 N/mm <sup>2</sup>	GJS-900-2 (GGG-90), GJS-1000-5 (ADI 1000), GJS-1200-2 (ADI 1200), GJS-1400-1 (ADI 1400)
	K3.1	Gusseisen mit Vermiculargraphit, GJV; Temperguss, GJM	< 500 N/mm <sup>2</sup>	GJV-300, GJV-400, GJMW-400-5 (GTW-40)
	K3.2	Gusseisen mit Vermiculargraphit, GJV; Temperguss, GJM	> 500 N/mm <sup>2</sup>	GJV-500, GJV-700
N	N1.1	Aluminium, unlegiert und legiert < 3 % Si		Alloy 2024, Alloy 7075, Al99
	N1.2	Aluminium, legiert ≤ 7 % Si		AlSi7
	N1.3	Aluminium, legiert > 7-12 % Si		AlSi9, AlSi9Cu
	N1.4	Aluminium, legiert > 12 % Si		AlSi12, AlSi17
	N2.1	Kupfer, unlegiert und niedriglegiert	< 300 N/mm <sup>2</sup>	SE-Cu
	N2.2	Kupfer, legiert	> 300 N/mm <sup>2</sup>	CuSn6
	N2.3	Messing, Bronze, Rotguss	< 1.200 N/mm <sup>2</sup>	CuZn33, CuAl9Mn3
	N3.1	Graphit, > 8 µm		
	N3.2	Graphit, ≤ 8 µm		
	N4.1	Kunststoff, Thermoplaste		PA, PE, PC, PS, PVC, PP, PTFE, POM, PMMA
N4.2	Kunststoff, Duroplaste		PU, PF, EP, UP, VE, CR	
N4.3	Kunststoff, Schaumstoffe		EPS, PUR, PVC-E, PS-E, PP-E	
C	C1.1	Kunststoffmatrix, Aramidfaserverstärkt (AFK)		Nomex, Kevlar, Twaron, KOREX
	C1.2	Kunststoffmatrix (duroplastisch), CFK/GFK		IMS, HTA
	C1.3	Kunststoffmatrix (thermoplastisch), CFK/GFK		GMT-PP, PEEK
	C2.1	Kohlenstoffmatrix, Kohlenstofffaserverstärkt (CFC)		CF222, CF225, CF226, CF227, CF260
	C3.1	Metallmatrix (MMC)		CeramTec AO-403 (AlSi9MgMn-Al2O3), Al/Cu/Mg-SiO2/Al2O3/AIN/TiC/SiC/BN/TiB2
	C4.1	Sandwichkonstruktion, Wabekern (Honeycomb)		
	C4.2	Sandwichkonstruktion, Schaumkern		PLASCORE PAMG-XR1 5052, PCGA-XR1 3003, PAMG-XR1 5056, Micro-Cell (core made of Alloy 5052/5056)
	C5.1	Schichtverbund (Stack), Nichtmetall-Nichteisenmetall-Verbund		CFK-Aluminium, IMS/HTA + Alloy 2024/6061/7075
	C5.2	Schichtverbund (Stack), Nichtmetall-Metall-Verbund		CFK-Titan, IMS/HTA + TiAl6V4/AMS4905
	C5.3	Schichtverbund (Stack), Nichtmetall-Nichtmetall-Verbund		CFK-CFK
C5.4	Schichtverbund (Stack), Nichteisenmetall-Nichteisenmetall-Verbund		Aluminium-Aluminium	
C5.5	Schichtverbund (Stack), Nichteisenmetall-Metall-Verbund		Aluminium-Titan	
C5.6	Schichtverbund (Stack), Metall-Metall-Verbund		Titan-Inox	
S	S1.1	Titan, Titanlegierungen	< 400 N/mm <sup>2</sup>	
	S2.1	Titan, Titanlegierungen	< 1.200 N/mm <sup>2</sup>	TiAl6V4
	S2.2	Titan, Titanlegierungen	> 1.200 N/mm <sup>2</sup>	
	S3.1	Nickel, unlegiert und legiert	< 900 N/mm <sup>2</sup>	1.3912 (Invar, Ni36)
	S3.2	Nickel, unlegiert und legiert	> 900 N/mm <sup>2</sup>	
	S4.1	Hochwarmfeste Superlegierung, Ni-, Co-, und Fe-basiert		Hardox, Hastelloy, Incoloy, Inconel, NIMONIC, Stellite, Waspaloy
S5.1	Wolfram- und Molybdänlegierungen			
H	H1.1	Gehärteter Stahl/Stahlguss	< 44 HRC	1.2738 HH, 1.2085, Toolox 33, Toolox 44
	H1.2	Gehärteter Stahl/Stahlguss	< 55 HRC	1.2343, 1.2311, 1.2312, 1.2714, 1.2083, 1.2738
	H2.1	Gehärteter Stahl/Stahlguss	< 60 HRC	1.1730, 1.2379, 1.2358, 1.2767, 1.4112, ASP 2012
	H2.2	Gehärteter Stahl/Stahlguss	< 65 HRC	1.2379, 1.2363, 1.2436, 1.2842, ASP 2005, Vanadis 23
	H2.3	Gehärteter Stahl/Stahlguss	< 68 HRC	ASP 2017, ASP 2023, Vanadis 30, Vanadis 60
H3.1	Verschleißbeständiger Guss/Hartguss, GJN			

\* Wenn die Legierungsbestandteile Cr, Mo, Ni, V, W in Summe > 8 %, dann die nächst höhere MILLER Zerspanungsgruppe wählen.

Ihr Spezialist für  
Vollhartmetall-Bohrer und -Fräser

Vollhartmetall-Bohrer für Stahl, Alu, Inox  
und gehärtete Materialien

Hochleistungsbohrer mit mehr Schneiden  
und zusätzlichen Führungsfasen

Wechselkopf-Bohrer TTD

Vollhartmetall-Fräserprogramm für Stahl, Alu, Inox  
und gehärtete Materialien

Hochleistungsfräser für hohe Zerspanvolumina

Werkzeugprogramm zur Bearbeitung  
moderner Werkstoffe und Superlegierungen

