

CBNCoat Drills | Solid CBN Reamers



**Die and Mold
Industry**



**Automotive
Mechanical Engineering**

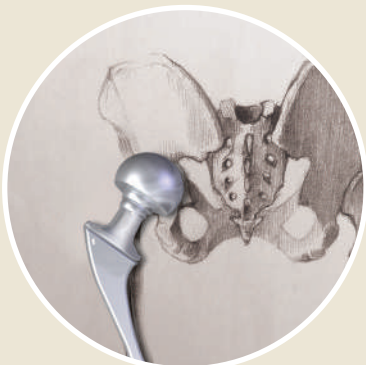
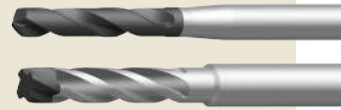

**Medical Technology
Micro Technology**



**Aerospace
Engineering**



About us

Diamond Tooling Systems



Welcome to DTS - Diamond Tooling Systems GmbH!

Based in Kaiserslautern - Germany - we have specialized in the development, production and distribution of precision tools equipped with ultrahard cutting materials, such as PCD (polycrystalline Diamond), CVD-D (CVD thickfilm Diamond), UltraDiamond (monocrystalline binderless Diamond) and CBN (cubic boron nitride). As a leading manufacturer for tools with lasered cutting edges, we offer machining solutions in the areas of turning, milling, grooving, drilling, reaming, threading, and tool holding.

To be able to economically process ultra-hard cutting materials such as PCD, CVD-D and CBN on precision tools werealized early on that we would have to move away from the traditional production technology of „grinding“ to new technologies such as the „laser removal process“. This decision has contributed to the fact that our customers regard us, DTS GmbH, as the pioneer and leading manufacturer of lasered tools for machining.

Ultra-hard high-performance cutting materials have a key function in Metal-cutting manufacturing. Precision tool-equipped with ultra-hard cutting materials are products that require a great deal of explanation. The economical use of the cutting materials is only ensured if the machining process and the cutting material are coordinated with each other.

This is exactly where we at DTS - Diamond Tooling Systems GmbH - step in: Tools and processes are subjected to a comprehensive analysis by our experienced application engineers. Subsequently, the new process optimization is presented to the customer and in the next step, it is implemented in their production. Only in that way is it possible to exploit the optimum potential of our high-tech cutting materials.

Our experienced application engineers are also available to advise you during ongoing production. This close cooperation and mutual trust is the basis of our success.

With more than 25 years of optimization experience in the processing industry, this is where we see our strength!

Contents

Drills and CBN Reamers

Overview

Ultrahard Cutting Materials at a Glance	04
Our Cutting Materials	06
Application examples - for Drilling and Reaming	07
Our Cutting Material Assignment	08
Our Drills and Reamers at a Glance	09

Products

CBNCoat Drills	10
Solid CBN Reamers	18

Technical Attachment

Cutting Parameters	22
Formulas	24
Copyright and Safety Instructions	31



You can also get all of our products via our online shop - anytime, fast and easy.
www.Diamond-tools24.com

PASSION FOR DIAMOND...

our Cutting Materials

... is not just a slogan for us - we live this passion in our daily dealings with our customers and we are your partner when it comes to Diamond or CBN tools.

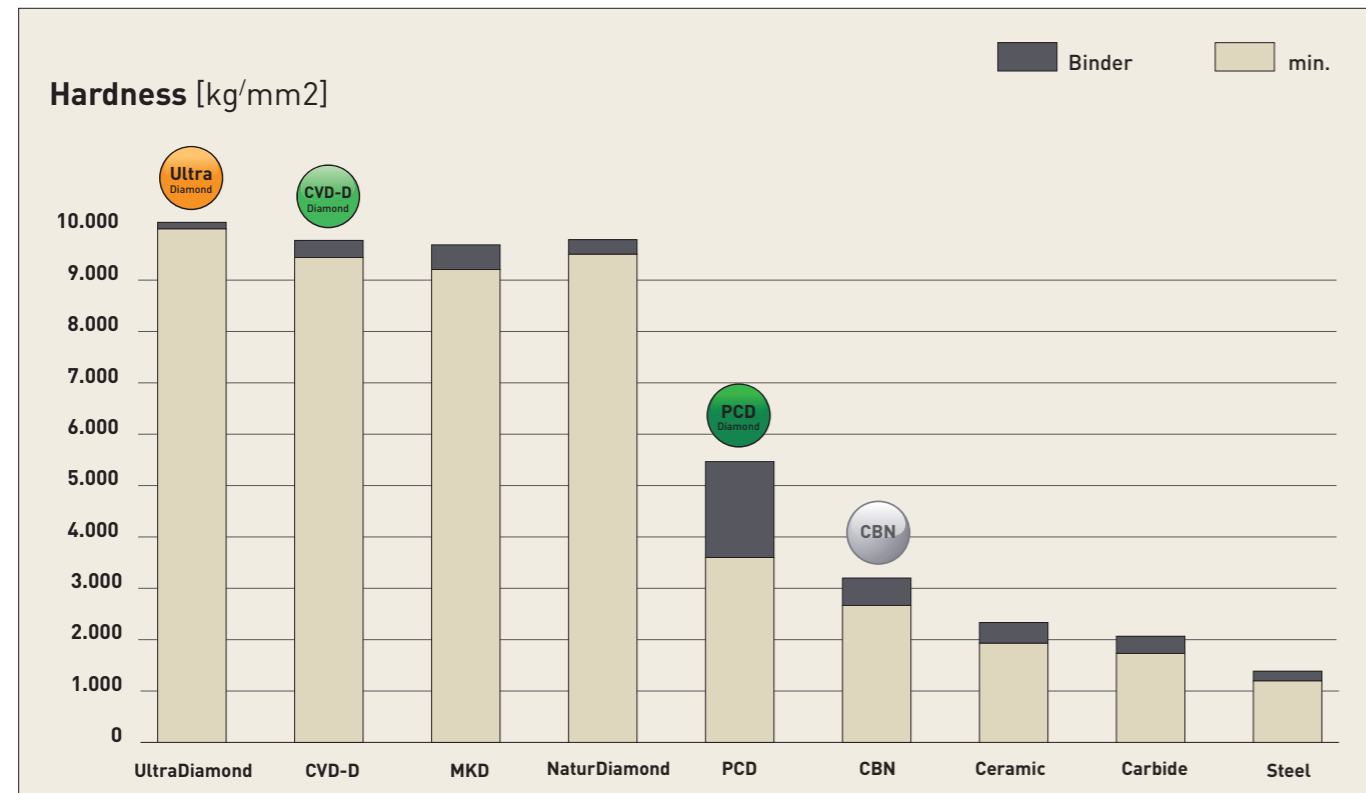

Polycrystalline Diamond (PCD)

The well-known standard Diamond

PCD is a synthetically produced, extremely tough, intergrown mass of Diamond particles with random orientation in a Metal matrix. It is produced by sintering selected Diamond particles at high pressure and high temperatures.

Graphite is used as a catalyst so that the PCD crystals grow together. PCD has high thermal conductivity and good heat dissipation from the cutting area. In addition, PCD has the highest bending strength of all cutting materials bending strength of all cutting materials.

PCD is very well suited for machining aluminium with a Si content of up to 10% and/or other abrasive fillers. The hot hardness is approx. 750°C, the areas of application are similar to those of CVD thick film Diamond, but the high efficiency of CVD thick film Diamond comes into its own with hard-brittle materials or aluminium with a Si content of 10% or more.

CVD thick film Diamond (CVD-D)

The star among Diamond Cutting Materials

For machining hard-brittle materials such as ceramics, glass, glass-ceramics, hard Metal, MMC and fibre composites such as CFK and GFK. Due to the lack of a bonding matrix, the Diamond content is much higher than with PCD. In the group of ultra-hard cutting materials, the binderless CVD-D is one of the hardest, artificially produced Diamond cutting materials.

CVD-D is characterised by high hardness and high wear resistance. These properties make CVD-D the perfect cutting material for machining abrasive materials. Compared to PCD, which is damaged by the abrasive particles due to its soft metallic binder phase, the CVD-D cutting edge remains stable due to its binderless anchoring in the Diamond matrix.

If CVD-D is used correctly, the service life can be increased by up to 10 times (and even more) compared to PCD!

Binderless Diamond (UltraDiamond)

The hardest single Crystal

Single-crystal elements are laser-cut from Diamond blanks in a defined orientation using laser segmentation technology. This new technology makes it possible, in addition to polycrystalline cutting materials such as PCD and CVD-D, to also braze a monocrystal (UltraDiamond) under high vacuum on any tool carrier. Compared to PCD, the tool life can be increased by approx. 15 to 25 times and compared to CVD-D by approx. 2 to 5 times.

The areas of application are similar to PCD and CVD-D, but this monocrystalline cutting material offers a further significant increase in tool life in all applications where PCD and CVD-D reach the limits of economic viability. The UltraDiamond cutting material makes economical machining of very hard, highly brittle materials such as Ceramics, glass, glass-Ceramics and hard metals with low cobalt binder and nickel binder (<10%) possible. Ceramics, glass, glass-ceramics and hard metals with low cobalt binder and nickel binder (<10%).

Polycrystalline Cubic Boron Nitride (CBN)

Chemically resistant and stable at high temperatures

CBN is stable up to 1,400°C. Boron nitride powder is the starting point for the production of CBN, which has been available since the late 1960s. It is produced under high pressure as well as at temperatures of over 1,500°C and is specially adapted to the final application through many different substrates.

Today, CBN is considered the second hardest material after Diamond cutting materials!

The applications of CBN are in the automotive industry, aerospace, tool and mould making and mechanical engineering. The wide spectrum as a cutting and abrasive material includes hardened Steels, Cast Iron, chilled Cast Iron, sintered materials, stellite, nickel and cobalt-based superalloys. In many applications, cubic boron nitride is preferred over Diamond cutting materials because it is absolutely stable in air at temperatures up to 1,400°C. Diamond, on the other hand, starts to decompose at a temperature of about 750°C.

Compared to PCD, CBN is also characterised by its chemical resistance to ferrous materials.

Our Cutting Materials

and their main areas of application at a glance

Untenstehend findest du eine Overview über unseren CBN Schneidstoff for our Drills and Reamers.

CBN

CBN
is ideally suited for the machining of *

Steels, hardened to 72 HRC
Sintered Steels, hardened
Cold- and Warmarbeitsstähle
Pulverstähle like CPM, ASP, Vanadis
Inconel, Titanium, Carbide

- continuous cut
- light interrupted cut
- heavy interrupted cut

Application examples

for Drilling and Reaming

Not only theory - we would like to show you our tools in action. Below you will find a selection of our CBN application videos. Click on the QR code for more information and the video.

Also visit our YouTube Channel at [dts-gmbh!](https://www.youtube.com/dts-gmbh)

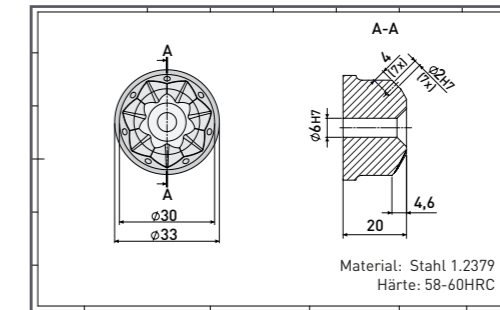

Drilling and Reaming
Steel 1.2379 58-60 HRC
Ø5,80

Here you can see the video!

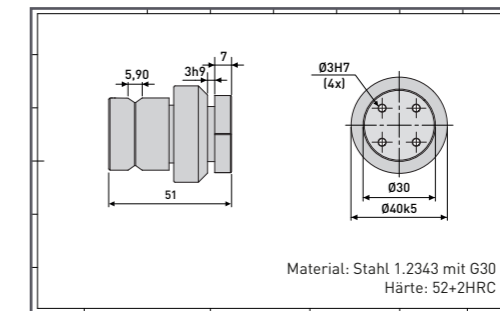

Drilling and Reaming
Steel 1.2343 52+2 HRC
Ø2,90

Here you can see the video!

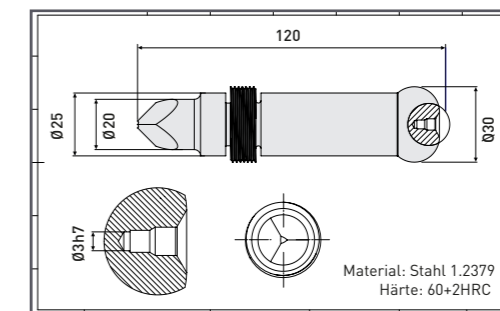
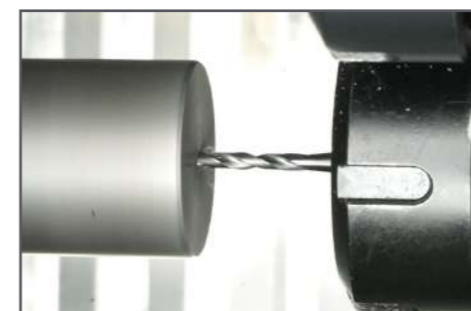

Drilling and Reaming
Steel 1.2379 60+2 HRC
Ø2,90

Here you can see the video!

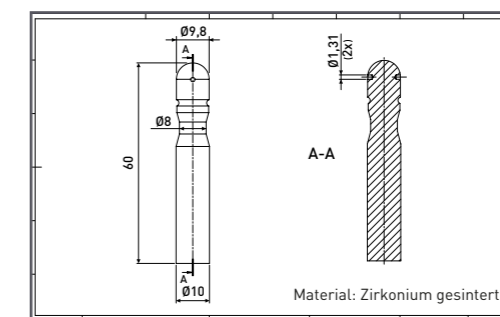

Sprödhartes bohren
Zirkonium gesintert
Solid Diamond

Here you can see the video!

* All other applications can be found in the complete cutting material classification starting on page 8

Our Cutting Material Assignment

DTS Drills and Reamers

You cannot find your material in the table?

We are glad to help you by phone or by mail!

Phone: +49 (0) 6301 32011-0

Mail: info@Diamond-toolingsystems.com

DTS cutting materials are successfully used in many industries:

- Mechanical Engineering
- Die and Mold Industry
- Automotive
- Aerospace
- Medical Technology
- optical Industry
- Ceramic Industry

1. Choice

ISO	Materials	DTS Types	
		CBNCoat Drills	CBNSolid Reamers
H	Cold Work Steel, hardened to 72 HRC	<input type="checkbox"/>	<input type="checkbox"/>
	PM- Steels (ASP, CPM, Vanadis, Böhler)	<input type="checkbox"/>	<input type="checkbox"/>
	Steel, hardened to 72 HRC	<input type="checkbox"/>	<input type="checkbox"/>
	Hot Work Steel, hardened to 72 HRC	<input type="checkbox"/>	<input type="checkbox"/>
	Tool Steel, hardened to 72 HRC	<input type="checkbox"/>	<input type="checkbox"/>
P	Sintered Steel	<input type="checkbox"/>	<input type="checkbox"/>
	Sintered Steel, hardened	<input type="checkbox"/>	<input type="checkbox"/>
K	Grey Cast Iron (GG)	<input type="checkbox"/>	<input type="checkbox"/>
	Ductile Cast Iron (GGG)	<input type="checkbox"/>	<input type="checkbox"/>
	Shell Chilled Cast Iron	<input type="checkbox"/>	<input type="checkbox"/>
S	Ni-, Co-, Fe- u. Cr-Alloys	<input type="checkbox"/>	<input type="checkbox"/>
	Titanium Alloys	<input type="checkbox"/>	<input type="checkbox"/>
M	Stainless Steel, hardened	<input type="checkbox"/>	<input type="checkbox"/>
N	Carbide, > 20% Co	<input type="checkbox"/>	<input type="checkbox"/>

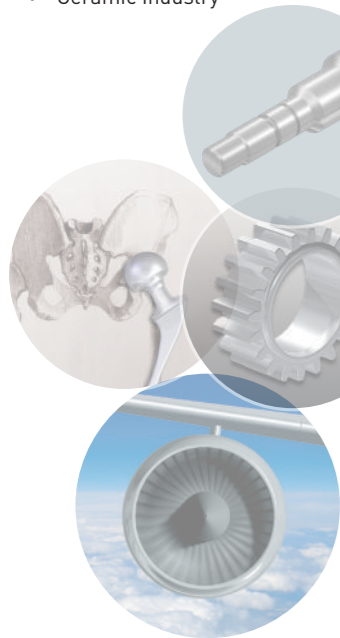

All Systems

for Drilling and Reaming

CBNCoat Drills

Ø 2,00 to Ø 12,00



A new coating called „CBNCoat“ has been developed for our CBNCoat Drills, which enables us to economically machine hardened materials up to 68HRC. Due to this new special coating, drilling of significantly softer materials is also possible without any problems.

Due to the special grinding, separate pre-centering is no longer necessary in many cases.

Overview of the main areas of application:

- ✓ Steel, hardened to 68 HRC
- ✓ Tool Steel, hardened to 68 HRC
- ✓ Inconel
- ✓ Titanium



Solid CBN Reamers

Ø 1,50 to Ø 6,03



Our Solid CBN Reamers are developed for use in high hardness materials. They can be used to produce H5, H6 and H7 bores in materials with a hardness of 50-72 HRC.

Due to the helix angle we guarantee an ideal chip removal and roundness!

Overview of the main areas of application:

- ✓ Steel, hardened to 72 HRC
- ✓ Tool Steel, hardened to 72 HRC
- ✓ Powder Metallurgy Steels, hardened to 72 HRC
- ✓ Inconel
- ✓ Titanium
- ✓ Carbide



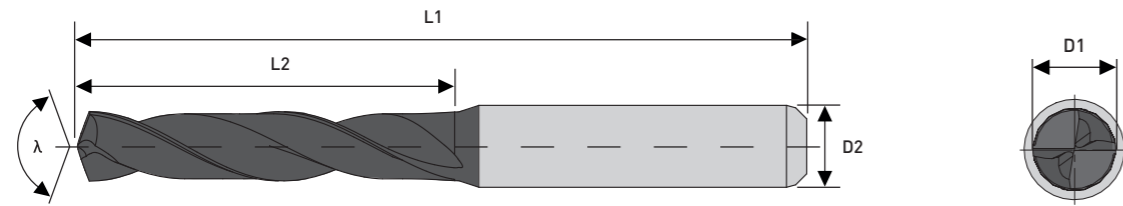

Cutting edges: 2
Coated
Shank according to DIN
6335-HA
Standard: DIN 6537 K
Shank tolerance: D2h6
Blade tolerance: D1h7

D1	L2	L1	D2	λ	Item No.
2,00	20,00	55,00	4,00	140°	B05980-0005
2,10	20,00	55,00	4,00	140°	B05980-0010
2,20	20,00	55,00	4,00	140°	B05980-0015
2,30	20,00	55,00	4,00	140°	B05980-0020
2,40	20,00	55,00	4,00	140°	B05980-0025
2,50	20,00	55,00	4,00	140°	B05980-0030
2,55	20,00	55,00	4,00	140°	B05980-0035
2,60	20,00	55,00	4,00	140°	B05980-0040
2,70	20,00	55,00	4,00	140°	B05980-0045
2,80	20,00	55,00	4,00	140°	B05980-0050
2,90	20,00	55,00	4,00	140°	B05980-0055
3,00	20,00	62,00	6,00	140°	B05980-0060
3,10	20,00	62,00	6,00	140°	B05980-0065
3,20	20,00	62,00	6,00	140°	B05980-0070
3,30	20,00	62,00	6,00	140°	B05980-0075

Application range:

- CBNCoat hardened Steel and Tool Steel to 68 HRC, pulvermetallurgischer Steel, Grey Cast Iron (GG), Ductile Cast Iron (GGG) ...

You will find further application ranges in the detailed overview on page 8.

D1	L2	L1	D2	λ	Item No.
3,40	20,00	62,00	6,00	140°	B05980-0080
3,50	20,00	62,00	6,00	140°	B05980-0085
3,60	20,00	62,00	6,00	140°	B05980-0090
3,70	20,00	62,00	6,00	140°	B05980-0095
3,80	24,00	66,00	6,00	140°	B05980-0100
3,90	24,00	66,00	6,00	140°	B05980-0105
4,00	24,00	66,00	6,00	140°	B05980-0110
4,10	24,00	66,00	6,00	140°	B05980-0115
4,20	24,00	66,00	6,00	140°	B05980-0120
4,30	24,00	66,00	6,00	140°	B05980-0125
4,40	24,00	66,00	6,00	140°	B05980-0130
4,50	24,00	66,00	6,00	140°	B05980-0135
4,60	24,00	66,00	6,00	140°	B05980-0140
4,70	24,00	66,00	6,00	140°	B05980-0145
4,80	28,00	66,00	6,00	140°	B05980-0150
4,90	28,00	66,00	6,00	140°	B05980-0155
5,00	28,00	66,00	6,00	140°	B05980-0160
5,10	28,00	66,00	6,00	140°	B05980-0165
5,20	28,00	66,00	6,00	140°	B05980-0170
5,30	28,00	66,00	6,00	140°	B05980-0175
5,40	28,00	66,00	6,00	140°	B05980-0180
5,50	28,00	66,00	6,00	140°	B05980-0185
5,60	28,00	66,00	6,00	140°	B05980-0190



Special tools on request for you!
Please send inquiries to info@Diamond-toolingsystems.com



All our products are also available in our online shop.
Visit us at Diamond-tools24.com



Scan me!

Subject to technical changes.

CBNCoat Drills

for hard drilling up to 68 HRC

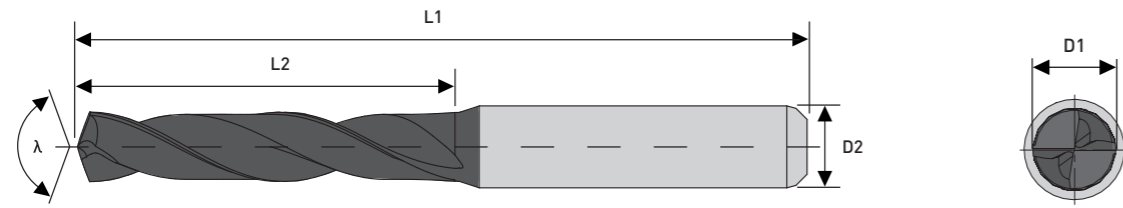

Cutting edges: 2
Coated
Shank according to DIN
6335-HA
Standard: DIN 6537 K
Shank tolerance: D2h6
Blade tolerance: D1h7

D1	L2	L1	D2	λ	Item No.
5,70	28,00	66,00	6,00	140°	B05980-0195
5,80	28,00	66,00	6,00	140°	B05980-0200
5,90	28,00	66,00	6,00	140°	B05980-0205
6,00	28,00	66,00	6,00	140°	B05980-0210
6,10	34,00	79,00	8,00	140°	B05980-0215
6,20	34,00	79,00	8,00	140°	B05980-0220
6,30	34,00	79,00	8,00	140°	B05980-0225
6,40	34,00	79,00	8,00	140°	B05980-0230
6,50	34,00	79,00	8,00	140°	B05980-0235
6,60	34,00	79,00	8,00	140°	B05980-0240
6,70	34,00	79,00	8,00	140°	B05980-0245
6,80	34,00	79,00	8,00	140°	B05980-0250
6,90	34,00	79,00	8,00	140°	B05980-0255
7,00	34,00	79,00	8,00	140°	B05980-0260
7,10	41,00	79,00	8,00	140°	B05980-0265

Application range:

- CBNCoat hardened Steel and Tool Steel to 68 HRC, pulvermetallurgischer Steel, Grey Cast Iron (GG), Ductile Cast Iron (GGG) ...

You will find further application ranges in the detailed overview on page 8.

D1	L2	L1	D2	λ	Item No.
7,20	41,00	79,00	8,00	140°	B05980-0270
7,30	41,00	79,00	8,00	140°	B05980-0275
7,40	41,00	79,00	8,00	140°	B05980-0280
7,50	41,00	79,00	8,00	140°	B05980-0285
7,60	41,00	79,00	8,00	140°	B05980-0290
7,70	41,00	79,00	8,00	140°	B05980-0295
7,80	41,00	79,00	8,00	140°	B05980-0300
7,90	41,00	79,00	8,00	140°	B05980-0305
8,00	41,00	79,00	8,00	140°	B05980-0310
8,10	47,00	89,00	10,00	140°	B05980-0315
8,20	47,00	89,00	10,00	140°	B05980-0320
8,30	47,00	89,00	10,00	140°	B05980-0325
8,40	47,00	89,00	10,00	140°	B05980-0330
8,50	47,00	89,00	10,00	140°	B05980-0335
8,60	47,00	89,00	10,00	140°	B05980-0340
8,70	47,00	89,00	10,00	140°	B05980-0345
8,80	47,00	89,00	10,00	140°	B05980-0350
8,90	47,00	89,00	10,00	140°	B05980-0355
9,00	47,00	89,00	10,00	140°	B05980-0360
9,10	47,00	89,00	10,00	140°	B05980-0365
9,20	47,00	89,00	10,00	140°	B05980-0370
9,30	47,00	89,00	10,00	140°	B05980-0375
9,40	47,00	89,00	10,00	140°	B05980-0380



Special tools on request for you!
Please send inquiries to info@Diamond-toolingsystems.com



All our products are also available in our online shop.
Visit us at Diamond-tools24.com



Scan me!

Subject to technical changes.

CBNCoat Drills

for hard drilling up to 68 HRC

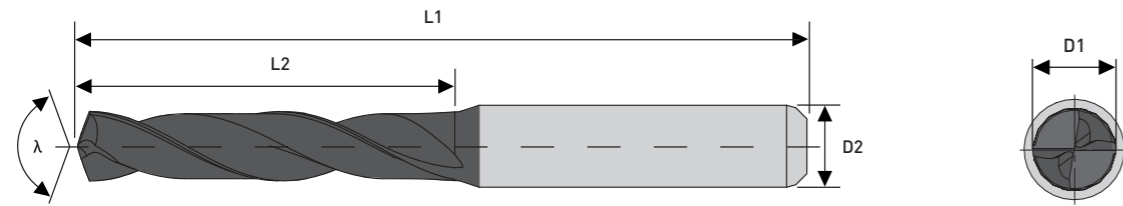

Cutting edges: 2
Coated
Shank according to DIN
6335-HA
Standard: DIN 6537 K
Shank tolerance: D2h6
Blade tolerance: D1h7

D1	L2	L1	D2	λ	Item No.
9,50	47,00	89,00	10,00	140°	B05980-0385
9,60	47,00	89,00	10,00	140°	B05980-0390
9,70	47,00	89,00	10,00	140°	B05980-0395
9,80	47,00	89,00	10,00	140°	B05980-0400
9,90	47,00	89,00	10,00	140°	B05980-0405
10,00	47,00	89,00	10,00	140°	B05980-0410
10,10	55,00	102,00	12,00	140°	B05980-0415
10,20	55,00	102,00	12,00	140°	B05980-0420
10,30	55,00	102,00	12,00	140°	B05980-0425
10,40	55,00	102,00	12,00	140°	B05980-0430
10,50	55,00	102,00	12,00	140°	B05980-0435
10,60	55,00	102,00	12,00	140°	B05980-0440
10,70	55,00	102,00	12,00	140°	B05980-0445
10,80	55,00	102,00	12,00	140°	B05980-0450
10,90	55,00	102,00	12,00	140°	B05980-0455

Application range:

● CBNCoat hardened Steel and Tool Steel to 68 HRC, pulvermetallurgischer Steel, Grey Cast Iron (GG), Ductile Cast Iron (GGG) ...

You will find further application ranges in the detailed overview on page 8.

D1	L2	L1	D2	λ	Item No.
11,00	55,00	102,00	12,00	140°	B05980-0460
11,10	55,00	102,00	12,00	140°	B05980-0465
11,20	55,00	102,00	12,00	140°	B05980-0470
11,30	55,00	102,00	12,00	140°	B05980-0475
11,40	55,00	102,00	12,00	140°	B05980-0480
11,50	55,00	102,00	12,00	140°	B05980-0485
11,60	55,00	102,00	12,00	140°	B05980-0490
11,70	55,00	102,00	12,00	140°	B05980-0495
11,80	55,00	102,00	12,00	140°	B05980-0500
11,90	55,00	102,00	12,00	140°	B05980-0505
12,00	55,00	102,00	12,00	140°	B05980-0510



Special tools on request for you!
Please send inquiries to info@Diamond-toolingsystems.com



All our products are also available in our online shop.
Visit us at Diamond-tools24.com



Scan me!

Subject to technical changes.

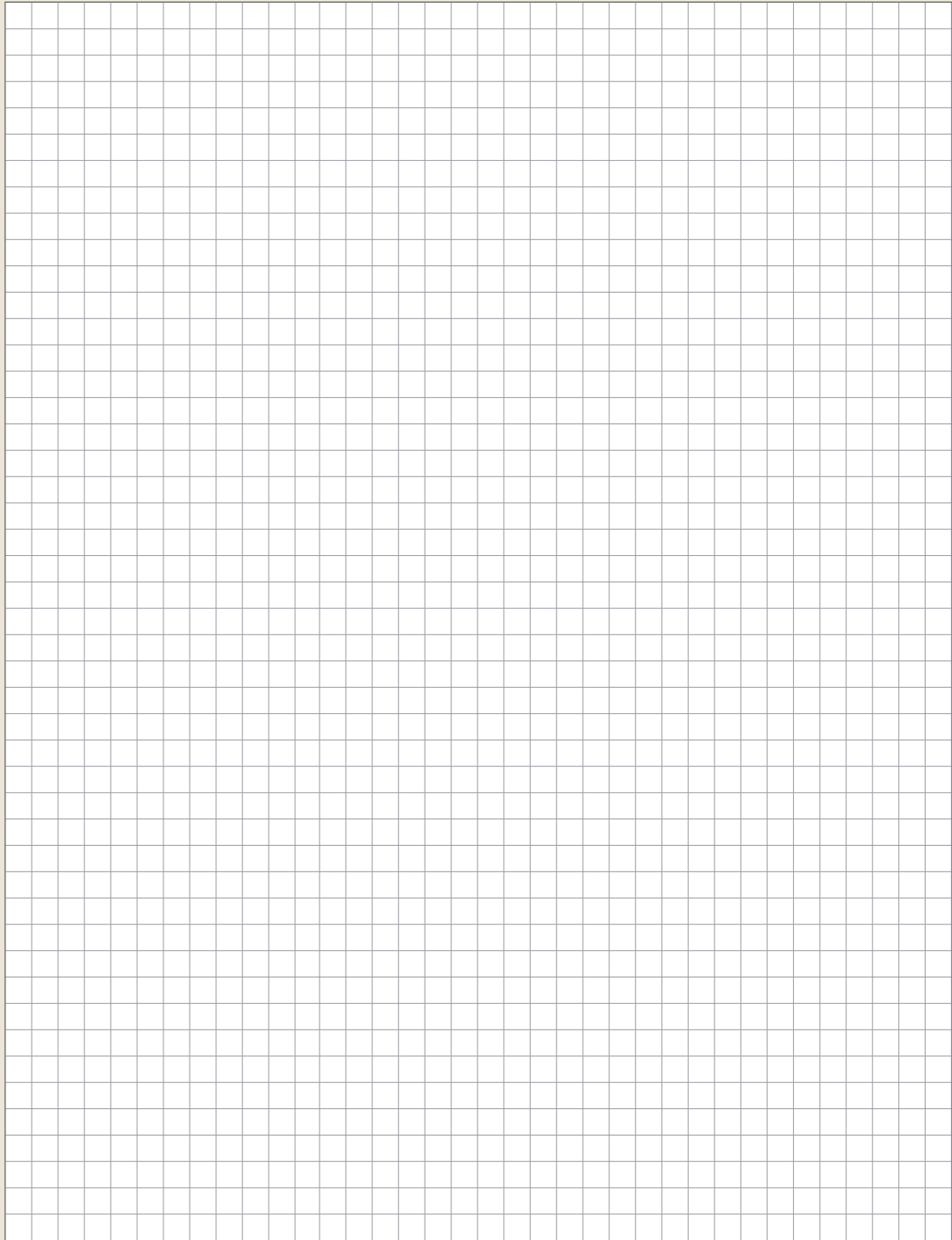
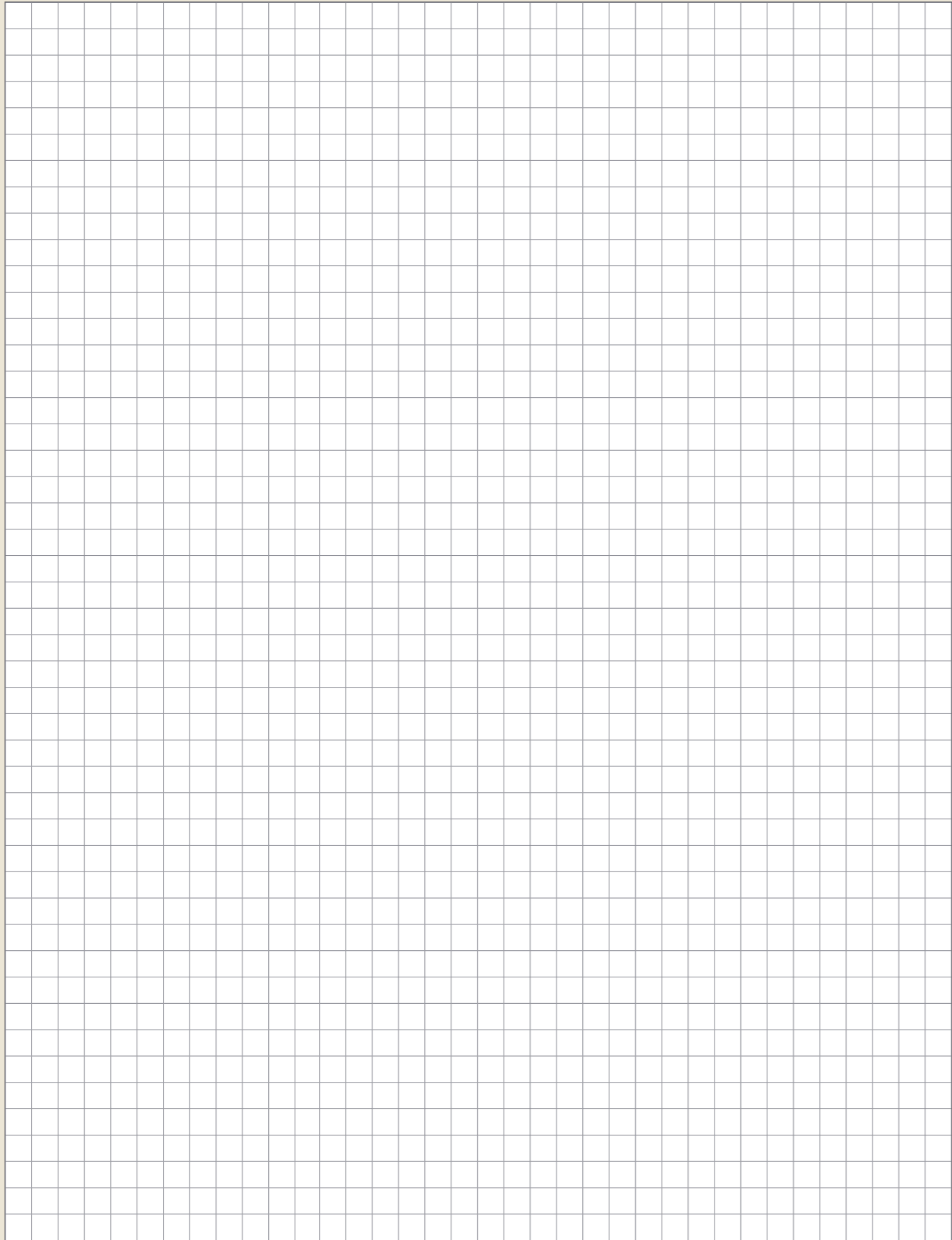

Solid CBN Reamers with Helix

for hard reaming up to 72 HRC

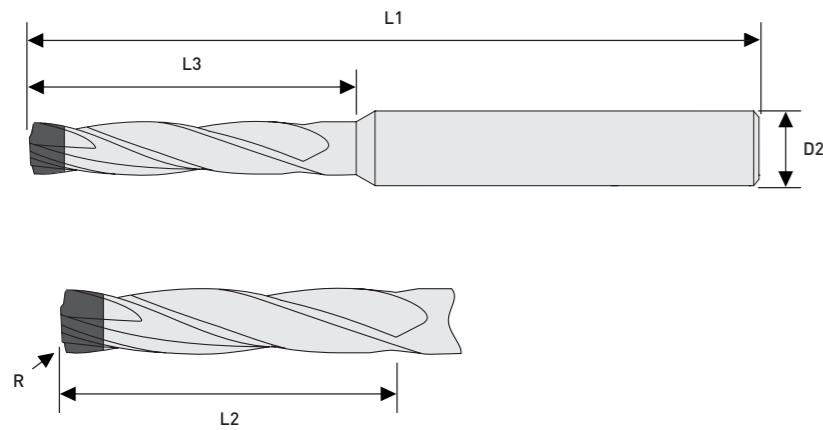

Cutting edges: 4
Shank tolerance: D2h4
Blade tolerance: D1 + 0,004mm
helix angle right

D1	L3	L2	L1	D2	R	Item No.
1,50	10,00	8,00	48,00	3,00	0,20	RA5940-0002
1,60	10,00	8,00	48,00	3,00	0,20	RA5940-0004
1,70	10,00	8,00	48,00	3,00	0,20	RA5940-0006
1,80	10,00	8,00	48,00	3,00	0,20	RA5940-0008
1,90	10,00	8,00	48,00	3,00	0,20	RA5940-0010
1,98	15,00	13,00	48,00	3,00	0,20	RA5940-0012
1,99	15,00	13,00	48,00	3,00	0,20	RA5940-0014
2,00	15,00	13,00	48,00	3,00	0,20	RA5940-0016
2,01	15,00	13,00	48,00	3,00	0,20	RA5940-0018
2,02	15,00	13,00	48,00	3,00	0,20	RA5940-0020
2,03	15,00	13,00	48,00	3,00	0,20	RA5940-0022
2,10	15,00	13,00	48,00	3,00	0,30	RA5940-0024
2,20	15,00	13,00	48,00	3,00	0,30	RA5940-0026
2,30	15,00	13,00	48,00	3,00	0,30	RA5940-0028
2,40	15,00	13,00	48,00	3,00	0,30	RA5940-0030

D1	L3	L2	L1	D2	R	Item No.
2,50	15,00	13,00	48,00	3,00	0,30	RA5940-0032
2,60	15,00	13,00	48,00	3,00	0,30	RA5940-0034
2,70	15,00	13,00	48,00	3,00	0,30	RA5940-0036
2,80	15,00	13,00	48,00	3,00	0,30	RA5940-0038
2,90	15,00	13,00	48,00	3,00	0,30	RA5940-0040
2,98	20,00	18,00	58,00	3,00	0,30	RA5940-0042
2,99	20,00	18,00	58,00	3,00	0,30	RA5940-0044
3,00	20,00	18,00	58,00	3,00	0,30	RA5940-0046
3,01	20,00	18,00	58,00	3,00	0,30	RA5940-0048
3,02	20,00	18,00	58,00	3,00	0,30	RA5940-0050
3,03	20,00	18,00	58,00	3,00	0,30	RA5940-0052
3,10	20,00	18,00	58,00	4,00	0,30	RA5940-0054
3,20	20,00	18,00	58,00	4,00	0,30	RA5940-0056
3,30	20,00	18,00	58,00	4,00	0,30	RA5940-0058
3,40	20,00	18,00	58,00	4,00	0,30	RA5940-0060
3,50	20,00	18,00	58,00	4,00	0,30	RA5940-0062
3,60	20,00	18,00	58,00	4,00	0,30	RA5940-0064
3,70	20,00	18,00	58,00	4,00	0,30	RA5940-0066
3,80	20,00	18,00	58,00	4,00	0,30	RA5940-0068
3,90	20,00	18,00	58,00	4,00	0,30	RA5940-0070
3,98	25,00	23,00	58,00	4,00	0,30	RA5940-0072
3,99	25,00	23,00	58,00	4,00	0,30	RA5940-0074
4,00	25,00	23,00	58,00	4,00	0,40	RA5940-0076

Application range:

- CBN hardened Steel and Tool Steel to 72 HRC, pulvermetallurgischer Steel, Sintered Steel hardened, Grey Cast Iron hardened, Carbide ...

You will find further application ranges in the detailed overview on page 8.



Special tools on request for you!
Please send inquiries to info@diamond-toolingsystems.com



All our products are also available in our online shop.
Visit us at Diamond-tools24.com



Scan me!

Subject to technical changes.

Solid CBN Reamers with Helix

for hard reaming up to 72 HRC

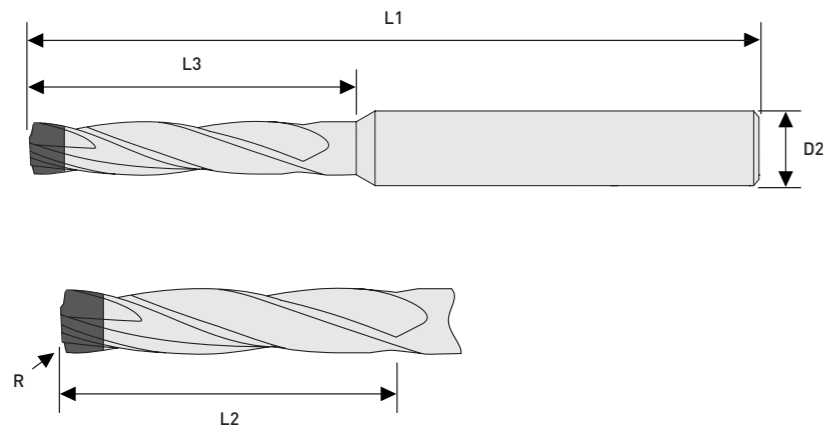

Cutting edges: 4
Shank tolerance: D2h4
Blade tolerance: D1 + 0,004mm
helix angle right

D1	L3	L2	L1	D2	R	Item No.
4,01	25,00	23,00	58,00	4,00	0,40	RA5940-0078
4,02	25,00	23,00	58,00	4,00	0,40	RA5940-0080
4,03	25,00	23,00	58,00	4,00	0,40	RA5940-0082
4,10	25,00	23,00	58,00	6,00	0,40	RA5940-0084
4,20	25,00	23,00	58,00	6,00	0,40	RA5940-0086
4,30	25,00	23,00	58,00	6,00	0,40	RA5940-0088
4,40	25,00	23,00	58,00	6,00	0,40	RA5940-0090
4,50	25,00	23,00	58,00	6,00	0,40	RA5940-0092
4,60	25,00	23,00	58,00	6,00	0,40	RA5940-0094
4,70	25,00	23,00	58,00	6,00	0,40	RA5940-0096
4,80	25,00	23,00	58,00	6,00	0,40	RA5940-0098
4,90	25,00	23,00	58,00	6,00	0,40	RA5940-0100
4,98	30,00	28,00	68,00	6,00	0,40	RA5940-0102
4,99	30,00	28,00	68,00	6,00	0,40	RA5940-0104
5,00	30,00	28,00	68,00	6,00	0,50	RA5940-0106

D1	L3	L2	L1	D2	R	Item No.
5,01	30,00	28,00	68,00	6,00	0,50	RA5940-0108
5,02	30,00	28,00	68,00	6,00	0,50	RA5940-0110
5,03	30,00	28,00	68,00	6,00	0,50	RA5940-0112
5,10	30,00	28,00	68,00	6,00	0,50	RA5940-0114
5,20	30,00	28,00	68,00	6,00	0,50	RA5940-0116
5,30	30,00	28,00	68,00	6,00	0,50	RA5940-0118
5,40	30,00	28,00	68,00	6,00	0,50	RA5940-0120
5,50	30,00	28,00	68,00	6,00	0,50	RA5940-0122
5,60	30,00	28,00	68,00	6,00	0,50	RA5940-0124
5,70	30,00	28,00	68,00	6,00	0,50	RA5940-0126
5,80	30,00	28,00	68,00	6,00	0,50	RA5940-0128
5,90	30,00	28,00	68,00	6,00	0,50	RA5940-0130
5,98	30,00	28,00	68,00	6,00	0,50	RA5940-0132
5,99	30,00	28,00	68,00	6,00	0,50	RA5940-0134
6,00	30,00	28,00	68,00	6,00	0,50	RA5940-0136
6,01	30,00	28,00	68,00	6,00	0,50	RA5940-0138
6,02	30,00	28,00	68,00	6,00	0,50	RA5940-0140
6,03	30,00	28,00	68,00	6,00	0,50	RA5940-0142

Application range:

- CBN hardened Steel and Tool Steel to 72 HRC, pulvermetallurgischer Steel, Sintered Steel hardened, Grey Cast Iron hardened, Carbide ...

You will find further application ranges in the detailed overview on page 8.



Special tools on request for you!
Please send inquiries to info@diamond-toolingsystems.com



All our products are also available in our online shop.
Visit us at Diamond-tools24.com



Scan me!

Subject to technical changes.

Cutting Parameters

for our CBNCoat Drills



		CBNCoat Drills								
			Ø 2	Ø 3	Ø 4	Ø 5	Ø 6	Ø 8	Ø 10	Ø 12
Material		V _c [m/min]	F [mm/U]	F [mm/U]	F [mm/U]	F [mm/U]	F [mm/U]	F [mm/U]	F [mm/U]	F [mm/U]
hardened Steel, 48-55 HRC	min.	20	0,010	0,030	0,050	0,060	0,070	0,070	0,080	0,090
	max.	35	0,050	0,060	0,080	0,090	0,100	0,100	0,110	0,120
hardened Steel, 55-60 HRC	min.	10	0,010	0,030	0,050	0,060	0,070	0,070	0,080	0,090
	max.	25	0,050	0,060	0,080	0,090	0,100	0,100	0,110	0,120
hardened Steel, 60-68 HRC	min.	10	0,010	0,030	0,050	0,060	0,070	0,070	0,080	0,090
	max.	20	0,050	0,060	0,080	0,090	0,100	0,100	0,110	0,120
Tool Steel, to 68 HRC	min.	10	0,020	0,030	0,050	0,060	0,070	0,070	0,080	0,080
	max.	30	0,050	0,060	0,080	0,100	0,100	0,100	0,110	0,120

Cooling Recommended

While machining with CBNCoat Drills, proper cooling is a key point.

1. Choice: Cool Emulsion

2. Choice: Oil



If you have any further technical questions, please do not hesitate to contact us by phone or e-mail!

Phone: +49(0)6301 32011-0

Mail: info@Diamond-toolingsystems.com

Cutting Parameters

for our Solid CBN Reamers



		Solid CBN Reamers						
			Ø 1,5	Ø 2	Ø 3	Ø 4	Ø 5	Ø 6
Material		V _c [m/min]	F [mm/U]	F [mm/U]	F [mm/U]	F [mm/U]	F [mm/U]	F [mm/U]
Steel, hardened 48-55 HRC	min.	10	0,010	0,010	0,020	0,030	0,030	0,030
	max.	30	0,030	0,040	0,070	0,070	0,090	0,090
Steel, hardened 55-60 HRC	min.	10	0,010	0,010	0,020	0,030	0,030	0,030
	max.	25	0,030	0,040	0,070	0,070	0,090	0,090
Steel, hardened 60-72 HRC	min.	10	0,010	0,010	0,030	0,030	0,030	0,030
	max.	25	0,030	0,030	0,070	0,070	0,090	0,090
Werkzeug-, and PM- Steel, to 72HRC	min.	10	0,010	0,010	0,030	0,030	0,030	0,030
	max.	30	0,030	0,030	0,070	0,070	0,090	0,090
Cast	min.	25	0,010	0,010	0,030	0,030	0,030	0,030
	max.	55	0,020	0,020	0,070	0,070	0,090	0,090
Carbide	min.	on request						
	max.	on request						

Cooling Recommended

While machining with Solid - CBN Reamers, proper cooling is a key point.

1. Choice: Cool Emulsion or Oil



If you have any further technical questions, please do not hesitate to contact us by phone or e-mail!

Phone: +49(0)6301 32011-0

Mail: info@Diamond-toolingsystems.com

Formulas

Drilling and Reaming

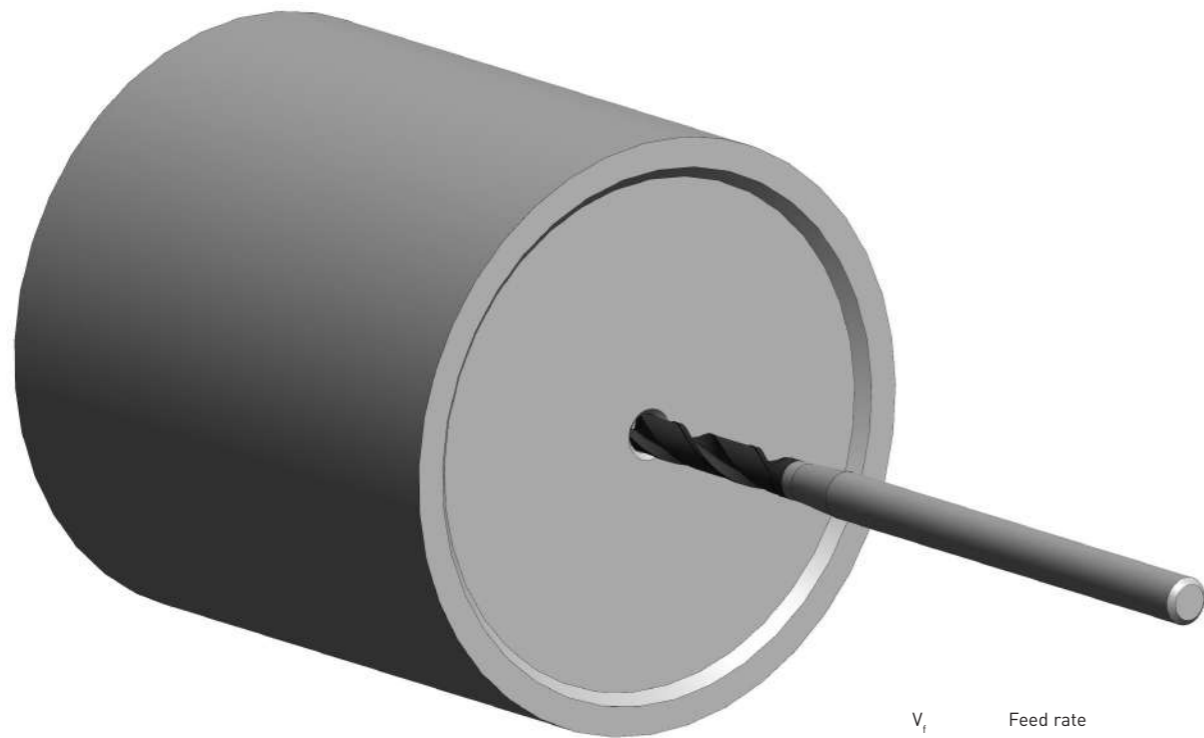

V_f	Feed rate	mm/min
f_n	Feed per revolution	mm/rev
n	Spindle speed	rev/min
v_c	Cutting speed	m/min
D_c	Cutter diameter	mm
t_c	Cutting Time	min
l_m	Cutting length	mm
Q	Stock removal rate	cm ³ /min
a_p	Cutting depth	mm

▶ Cutting speed

$$V_c = \frac{D_c \times \pi \times n}{1000} \quad [\text{m/min}]$$

▶ Spindle speed

$$n = \frac{v_c \times 1000}{\pi \times D_c} \quad [\text{U/min}]$$

▶ Feed per revolution

$$f_n = \frac{V_f}{n} \quad [\text{mm/U}]$$

▶ Cutting time

$$t_c = \frac{l_m}{f_n \times n} \quad [\text{min}]$$

▶ Stock removal rate

$$Q = \frac{v_f \times d \times n^2}{4 \times 1000} \quad [\text{cm}^3/\text{min}]$$

Your Notes

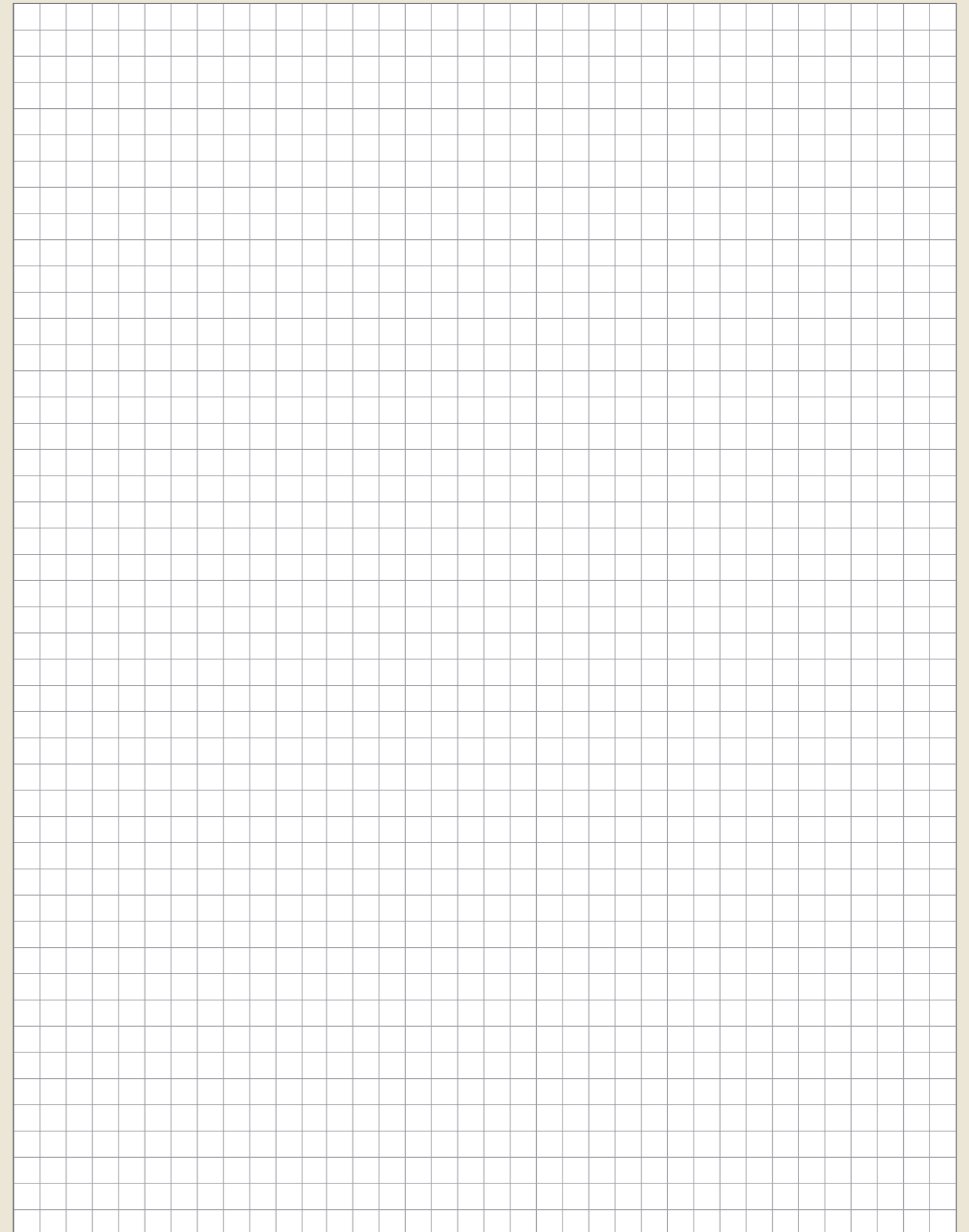

A large rectangular area filled with a fine grid pattern, intended for taking notes.A large rectangular area filled with a fine grid pattern, intended for taking notes.

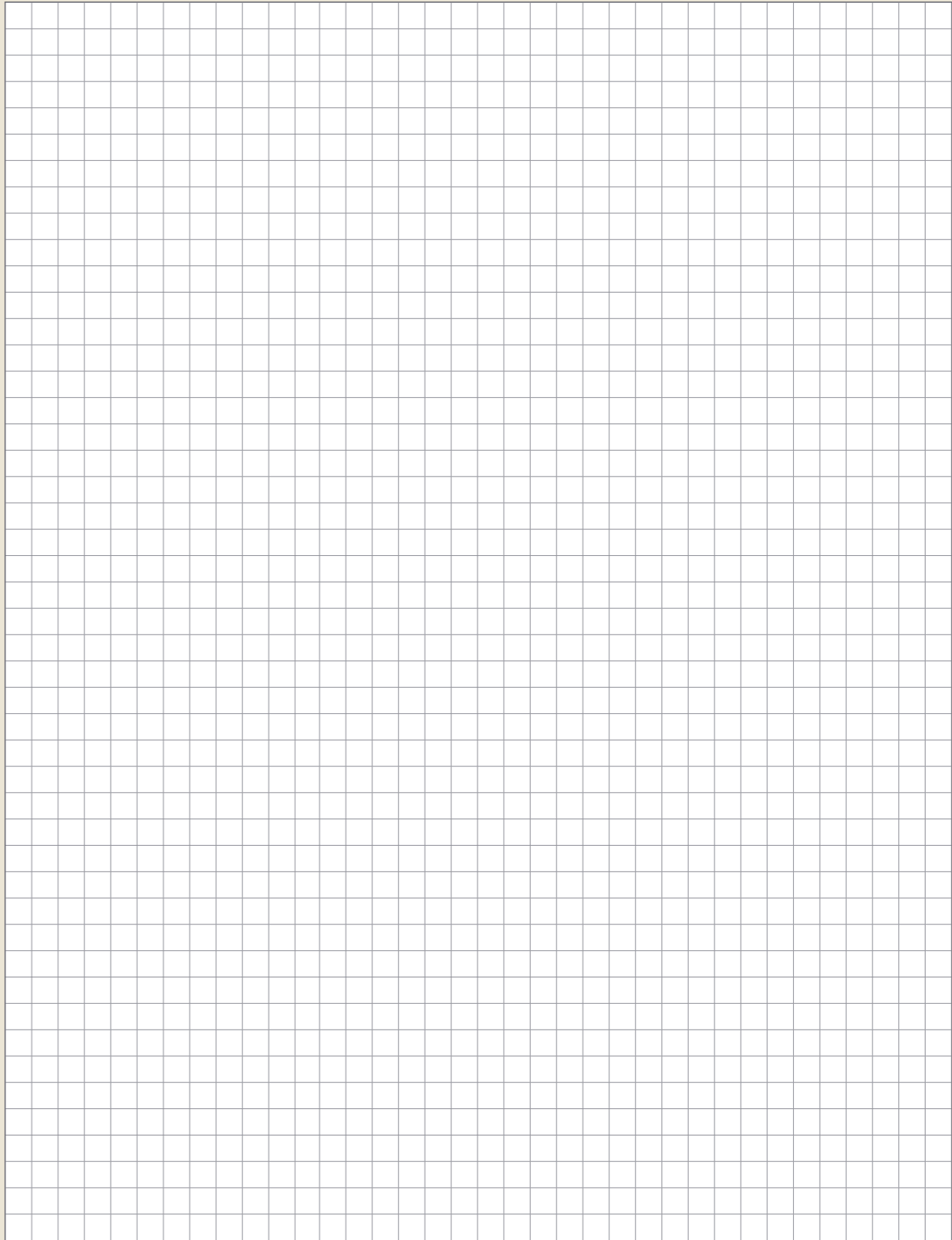
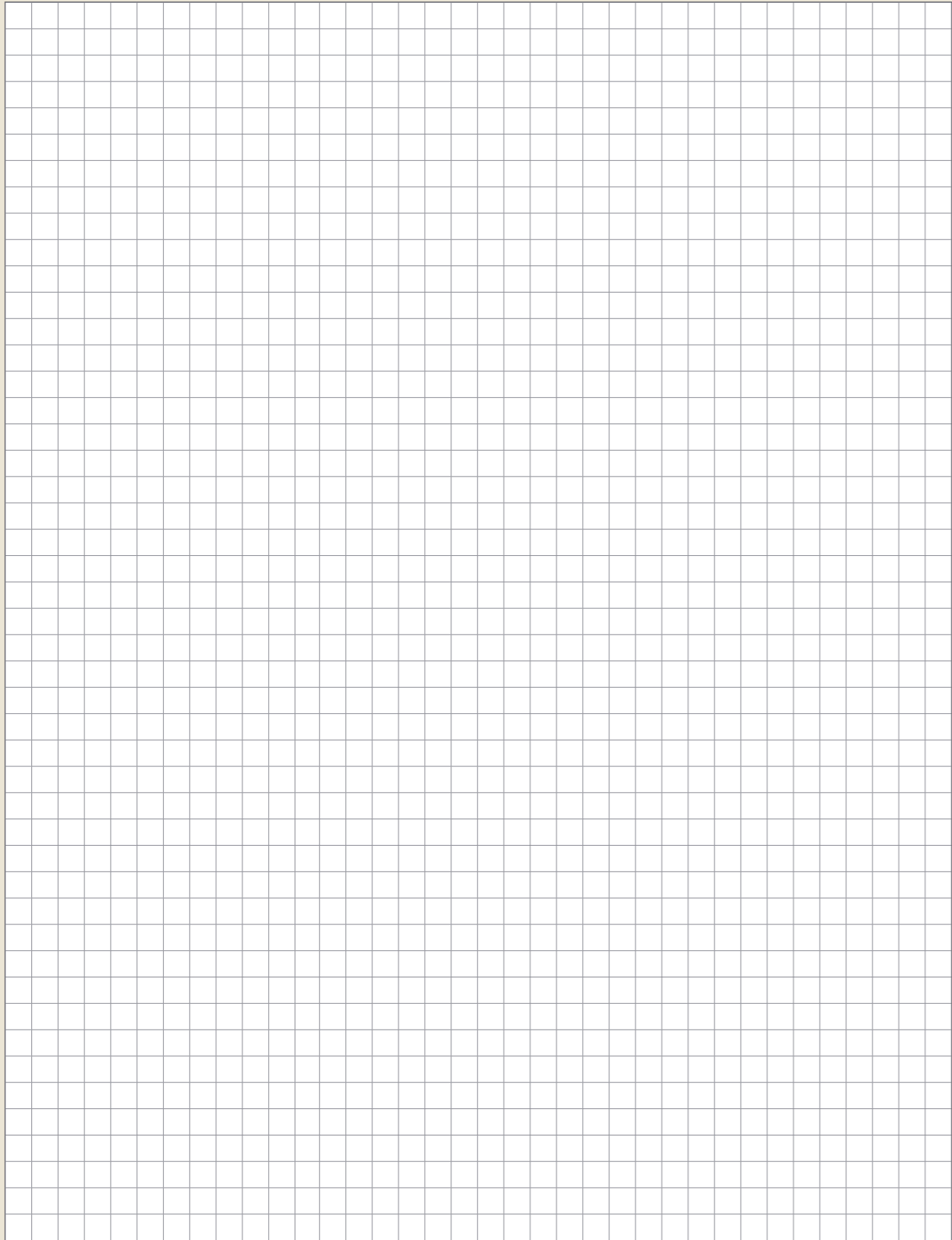



Instagram



YouTube



LinkedIn



DTS Shop



DTS Webseite



PASSION FOR DIAMOND

Hans-Geiger-Straße 11a · D-67661 Kaiserslautern

+49 (0) 6301 32011-0

+49 (0) 6301 32011-90

info@Diamond-toolingsystems.com

Homepage: www.Diamond-toolingsystems.com

Shop: www.Diamond-tools24.com