

**TERA**  
*—speed*

**Höchstgeschwindigkeit  
für das Fräsen von Guss**  
**Top speed for cast machining**

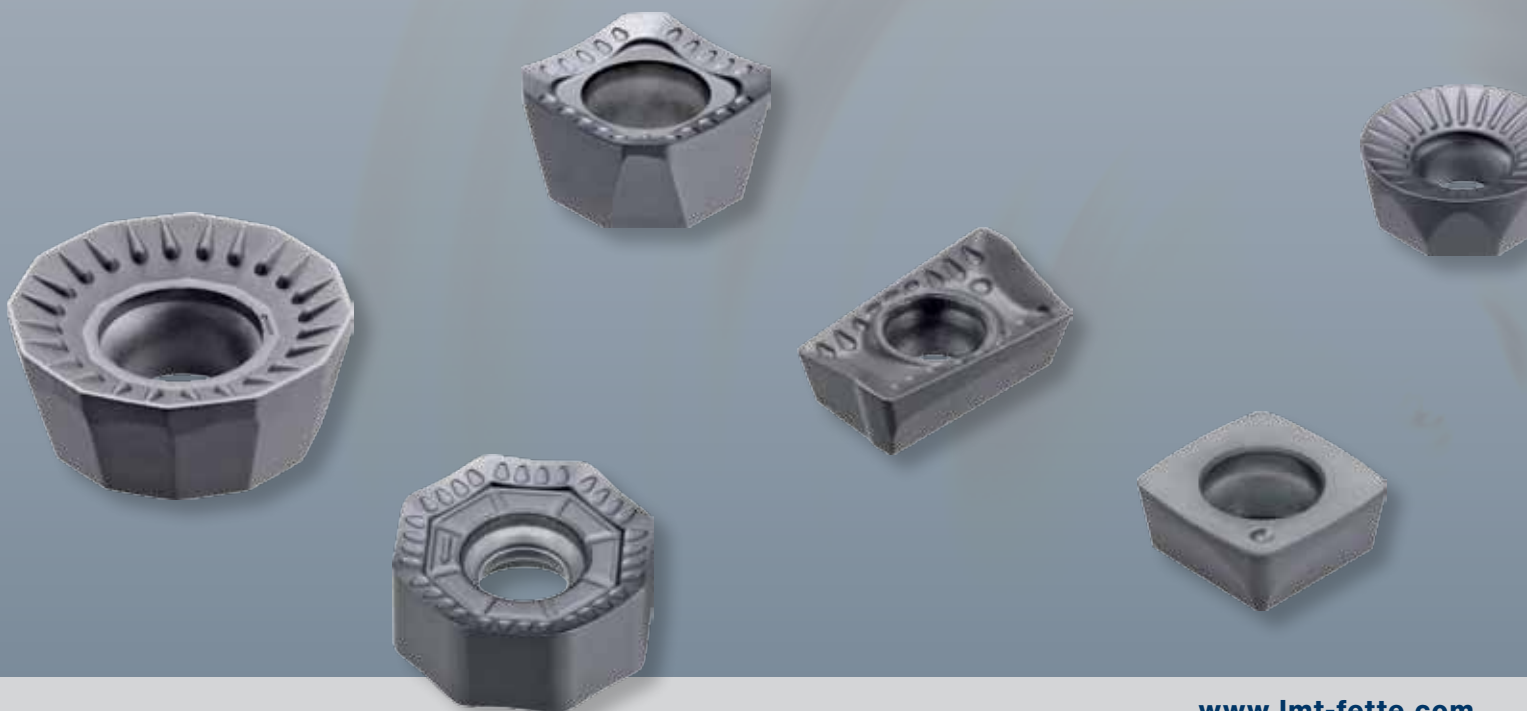

**Bis zu 200 Prozent höhere Produktivität bei der Bearbeitung von Gusswerkstoffen mit der neuen leistungsfähigen LMT Fräsorte LCK10M**

**Up to 200 percent higher productivity in machining of cast materials with the new high-performance milling grade LMT LCK10M**

Extrem hohe Schnittgeschwindigkeit, extrem niedriger Verschleiß – mit der neuen TERAspeed-Beschichtung für Wendeschneidplatten setzt LMT neue Geschwindigkeits- und Standzeitrekorde beim Fräsen von Guss. Möglich macht das eine Revolution in der Beschichtungstechnik: LMT TERAspeed ist die weltweit erste kubische AlTiN Schicht mit einem Aluminiumgehalt über 90 %, die über ein CVD-Verfahren abgeschieden wird.

Extremely high cutting speed, extremely low wear – with the new TERAspeed coating for inserts LMT is setting new speed and tool life records when milling cast iron. This is made possible by a revolution in coating technology: LMT TERAspeed is the world’s first cubic AlTiN coating with an aluminum content above 90 %, which is deposited via a CVD process.

TERAspeed kombiniert die entscheidenden Vorteile von PVD- und CVD-Schichtsystemen: Die neue Beschichtung ist zäh und temperaturstabiler als eine PVD-AlTiN-Schicht und besitzt die hohe Haftfestigkeit aus den CVD-Verfahren. Anwender profitieren gleichermaßen von hohen Zerspanleistungen wie von einer garantierten Prozesssicherheit – gerade bei Anwendungen mit stark unterbrochenem Schnitt.

TERAspeed combines the key advantages of PVD and CVD coating systems: The new coating is tough and thermally more stable than a PVD AlTiN coating and has the high adhesion known from the CVD process. Users will benefit equally from high cutting speeds as well as guaranteed process stability – especially in applications with frequently interrupted cutting processes.

Moderne Gusslegierungen stellen höchste Anforderungen an Zerspanungswerkzeuge. Mit der neuen TERAspeed-Beschichtung für Wendeschneidplatten stellen diese keine Herausforderung mehr dar. In Verbindung mit den MultiEdge- und Univex-Premium-Frässystemen von LMT Fette können Sie ihre Produktivität mit TERAspeed um bis zu 200 Prozent erhöhen.

Modern casting alloys demand the highest performance and quality from cutting tools. With the new TERAspeed coating for carbide inserts, these no longer represent a challenge. In conjunction with the MultiEdge and Univex Premium cutting systems by LMT Fette, you can increase your productivity with TERAspeed by up to 200 percent.

**Ihre Vorteile:**

- Mehr als 100 Prozent höhere Schnittgeschwindigkeit beim Plan- und Eckfräsen
- Bis zu 200 Prozent längere Standzeiten
- Garantierte Prozesssicherheit, auch bei stark unterbrochenem Schnitt

**Your advantages:**

- More than 100 percent higher cutting speeds during face and 90° milling
- Up to 200 percent higher tool life
- Guaranteed process reliability even with heavily interrupted cuts



### Eckfräsen in GJS 600-3 Step milling with GJS 600-3

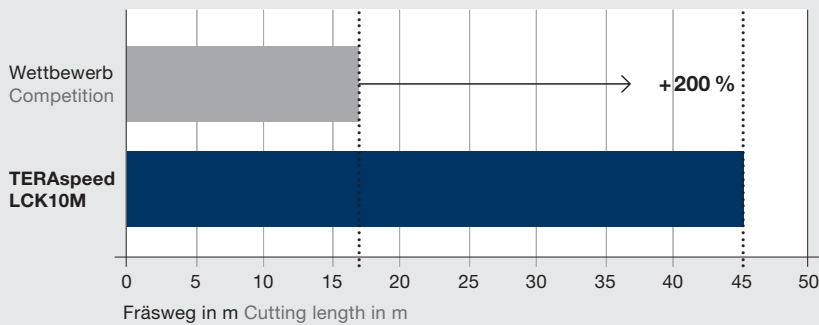

#### Werkzeug Tool:

Univex Premium FMU 90 A12.040AN-I  
Univex Premium FMU 90 A12.040AN-I  
Durchmesser Diameter: 40 mm  
Schneidenzahl Cutting edge number: 4

**Wendeplatte Insert:**  
ADKX 120412 SR-TR

**Werkstoff Material:**  
GJS 600-3

#### Schnittwerte Cutting data:

$v_c = 150$  m/min  
 $n = 1194$  min<sup>-1</sup>  
 $f_z = 0,2$  mm  
 $v_f = 955$  mm/min  
 $a_e = 32$  mm  
 $a_p = 3$  mm

### Planfräsen in GJS 600-3 Face milling with GJS 600-3

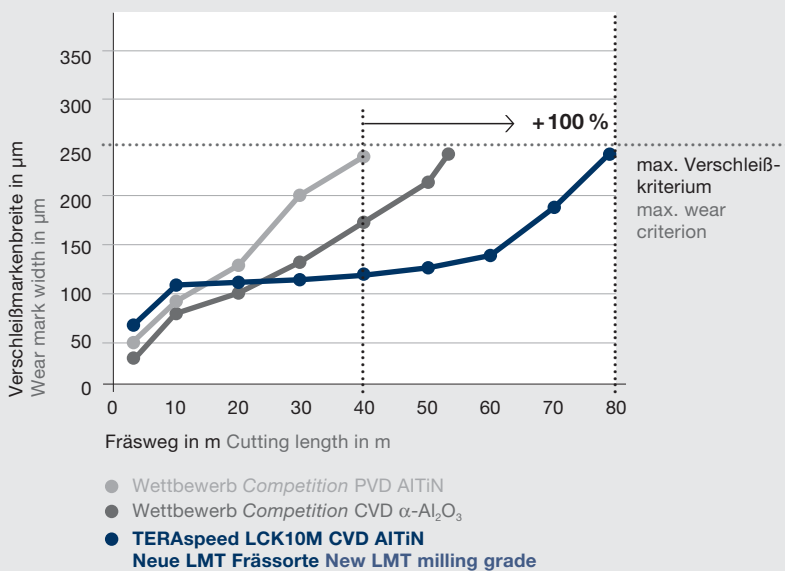

#### Werkzeug Tool:

FCT45 Planfräser  
FCT45 face cutter  
Durchmesser Diameter: 52 mm  
Schneidenzahl Cutting edge number: 4

**Wendeplatte Insert:**  
OCKX 0606 ADTR

**Werkstoff Material:**  
GJS 600-3

#### Schnittwerte Cutting data:

$v_c = 210$  m/min  
 $n = 1286$  min<sup>-1</sup>  
 $f_z = 0,3$  mm  
 $v_f = 1543$  mm/min  
 $a_e = 30$  mm  
 $a_p = 3$  mm

**NEW**

#### LCK10M

TERAspeed (AITiN-CVD) beschichtete Feinstkornhartmetallsorte für das Fräsen von Gusswerkstoffen. Durch die hohe Temperaturbeständigkeit besonders geeignet für Trockenzerspanung bei hohen Schnittgeschwindigkeiten.

TERAspeed (AITiN CVD) coated micro-grain carbide grade for milling cast iron materials. Especially well suited for dry machining at high cutting speeds due to the high temperature resistance.

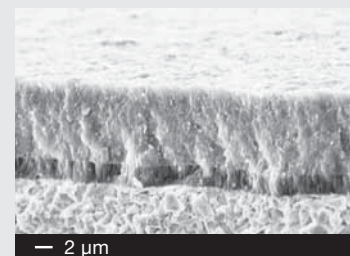
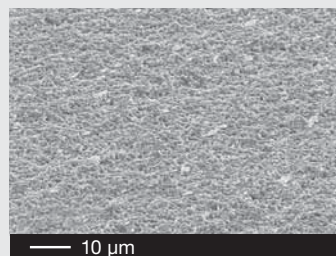

Detailansicht Feinstkornhartmetall (links) und Schichtaufbau TERAspeed (rechts).  
Detail of micor-grade carbide grade (left) and coating structure of TERAspeed (right).

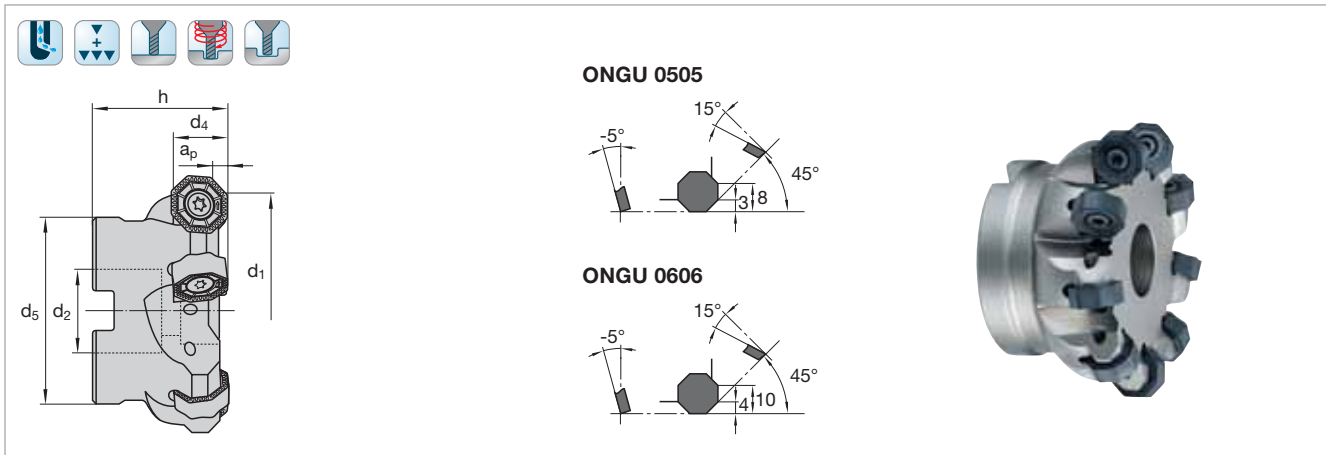



Katalog-Nr. Cat.-No.								FMN45 IK <sup>1)</sup>			
d <sub>1</sub>	d <sub>4</sub>	h	d <sub>5</sub>	d <sub>2</sub>	z	a <sub>p</sub>	Ident No.	LMT-Code			
32	12,7	40	32	16	3	3	1027400	FMN45 005.032AN-I	ONGU 0505	1045131	1048335 T15
32	12,7	40	32	16	4	3	1027401	FMN45 005.032AN-IF			
40	12,7	40	40	22	4	3	1027402	FMN45 005.040AN-I			
40	12,7	40	40	22	5	3	1027403	FMN45 005.040AN-IF			
50	12,7	40	40	22	5	3	1027404	FMN45 005.050AN-I			
50	12,7	40	40	22	7	3	1027405	FMN45 005.050AN-IF			
63	12,7	40	50	22	7	3	1027406	FMN45 005.063AN-I	ONGU 0606	1045133	1048422 20 IP
63	12,7	40	50	22	9	3	1027407	FMN45 005.063AN-IF			
50	16	40	40	22	4	4	1027420	FMN45 006.050AN-I			
50	16	40	40	22	6	4	1027421	FMN45 006.050AN-IF			
63	16	40	50	22	5	4	1027422	FMN45 006.063AN-I			
63	16	40	50	22	8	4	1027423	FMN45 006.063AN-IF			
80	16	50	60	27	7	4	1027424	FMN45 006.080AN-I			
80	16	50	60	27	10	4	1027425	FMN45 006.080AN-IF			
100	16	50	75	32	9	4	1027426	FMN45 006.100AN-I			
100	16	50	75	32	12	4	1027427	FMN45 006.100AN-IF			
125	16	63	90	40	11	4	1027428	FMN45 006.125AN			
125	16	63	90	40	15	4	1027429	FMN45 006.125AN-F			
160	16	63	130	40	13	4	1027430	FMN45 006.160AN			
160	16	63	130	40	19	4	1027431	FMN45 006.160AN-F			

<sup>1)</sup> Fräser auch verfügbar in Zoll  
 Cutters also available in inch

Schnittwertempfehlungen siehe Seite 23  
 Cutting data recommendations see page 23

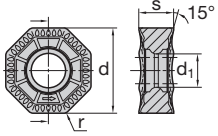
Wendeschneidplatten für MultiEdge Double 8 Planfräsköpfe 45°  
 Indexable inserts for MultiEdge double 8 face milling cutters 45°

							Schneidstoffsorten Cutting materials Ident No.	Für Fräser For cutter  Cat-No.
N = Anzahl der Schneidkanten N = Number of cutting edges	LMT-Code	l	d	s	d <sub>1</sub>	r	<b>NEW</b> LCK10M	
  <p>N = 16 (ANEN) N = 8 (ANEN-SL)</p>	ONGU 0505 ANEN	-	12,7	5,56	4,4	2	7048392	FMN45 IK
	ONGU 0606 ANEN	-	16	6,35	6,3	2	7048393	
								P
								M
								K
								N
								S
								H

■ = Hauptanwendung First choice

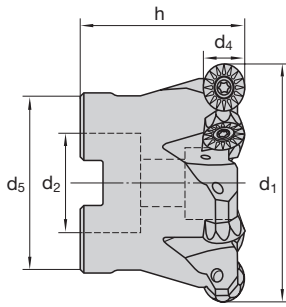

**OCKX 0505**

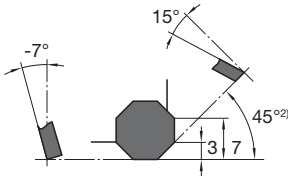

**RCKX 1205**

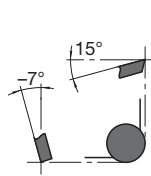

**SAHT 1005**

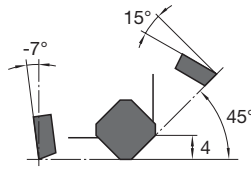

**XCKX 1606**

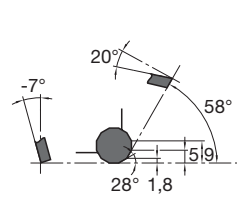

**OCKX 0606**

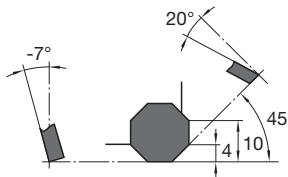

**RCKX 1606**

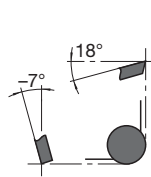

**SAHT 1306**

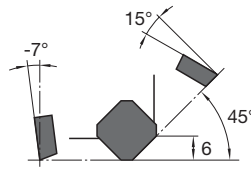

**XOKX 1606**

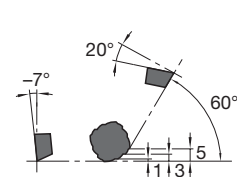

Katalog-Nr. Cat.-No.

FCT45<sup>1)</sup>

d <sub>1</sub>	d <sub>4</sub>	h	d <sub>5</sub>	d <sub>2</sub>	z	Ident No.	LMT-Code					
42	12	40	32	16	4	1041007	FCT45 005.042AN-I	OCKX 0505	RCKX 1205	SAHT 1005	1045131	1048335 T15
52	12	40	40	22	5	1041008	FCT45 005.052AN-I					
66	12	50	50	27	6	1041009	FCT45 005.066AN-I					
80	12	50	60	27	7	1041010	FCT45 005.080AN-I					
52	16	40	40	22	4	1041011	FCT45 006.052AN	OCKX 0606	RCKX 1606	SAHT 1306	1045777	1048344 T20
66	16	50	48	27	5	1041012	FCT45 006.066AN					
80	16	50	60	27	6	1041013	FCT45 006.080AN					
100	16	50	65	32	7	1041014	FCT45 006.100AN					
125	16	63	90	40	8	1041015	FCT45 006.125AN					
160	16	63	95	40	9	4053555	FCT45 006.160AN					

<sup>1)</sup> Fräser auch verfügbar in Zoll  
Cutters also available in inch

<sup>2)</sup> Winkel am Werkstück 43°  
Angle on workpiece 43°

Schnittwertempfehlungen siehe Seite 23  
Cutting data recommendations see page 23

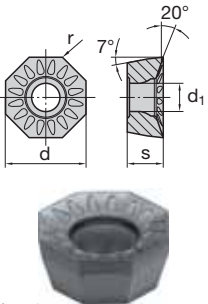
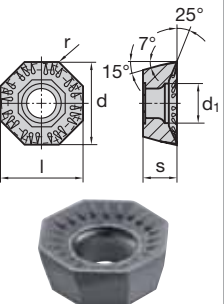
							Schneidstoffsorten Cutting materials Ident No.	
N = Anzahl der Schneidkanten N = Number of cutting edges	LMT-Code	l	d	s	d <sub>1</sub>	r	NEW LCK10M 7047992	Für Fräser For cutter
								Cat-No.
 <p>N = 8</p>	OCKX 0505 AD-TR	12	12	5,56	4,4	0,5	7047992	FCT45
	OCKX 0606 AD-TR	16	16	6,35	5,8	0,5	7047993	FCT45
 <p>N = 8</p>	OCKX 0606 AD-TRT	16	16	6,35	5,8	0,5	7047994	FCT45
	RCKX 1205 MO-TR	-	12	5,56	4,4	-	7047995	FCT45
								P
								M
								K
								N
								S
								H

■ = Hauptanwendung First choice

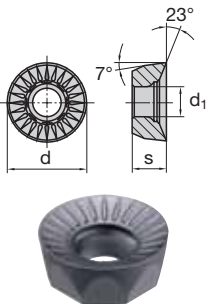
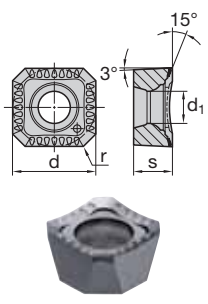
							Schneidstoffsorten Cutting materials Ident No.	Für Fräser For cutter  Cat-No.
N = Anzahl der Schneidkanten N = Number of cutting edges	LMT-Code	l	d	s	d <sub>1</sub>	r	<b>NEW</b> LCK10M	
	RCKX 1606 MO-TR	-	16	6,35	5,8	-	7047996	FCT45
	RCKX 1606 MO-TRT	-	16	6,35	5,8	-	7047997	
 <p>N = 4</p>	SAHT 1005 AA ER	10	10	5,56	4,4	0,8	7048354	FCT45
	SAHT 1306 AA EN	13,5	13,5	6,35	5,5	0,8	7048355	
								P
								M
■								K
								N
								S
								H

■ = Hauptanwendung First choice



## MultiEdge 4Feed Aufschraubfräser MultiEdge 4Feed Screw-on type end mills

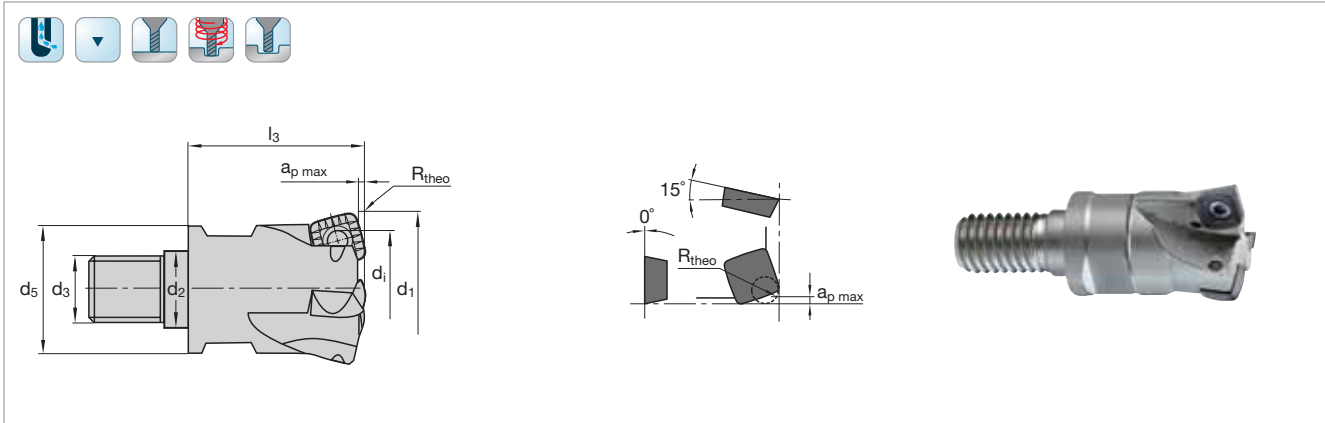

Katalog-Nr. Cat.-No.										ECP V07 IK <sup>1)</sup>			
d <sub>1</sub>	d <sub>i</sub>	l <sub>3</sub>	d <sub>3</sub>	d <sub>5</sub>	d <sub>2</sub>	z	a <sub>p max</sub>	R <sub>theo</sub>	Ident No.	LMT-Code			
20	6,9	30	M10	18	10,5	2	1	1,5	7028485	ECP V07.020TS030-I	XCNT 070308 SN-TR XCNT 070308 SN	9199156	1048326 T8
25	12	33	M12	21	12,5	3	1	1,5	7028486	ECP V07.025TF033-I			
32	19	43	M16	29	17	3	1	1,5	7028487	ECP V07.032TH043-I			
32	19	43	M16	29	17	4	1	1,5	7028488	ECP V07.032TH043-IF			
35	22	43	M16	29	17	5	1	1,5	7028489	ECP V07.035TH043-I			

<sup>1)</sup> Fräser auch verfügbar in Zoll  
Cutters also available in inch

## MultiEdge 4Feed Schaftfräser MultiEdge 4Feed end mills

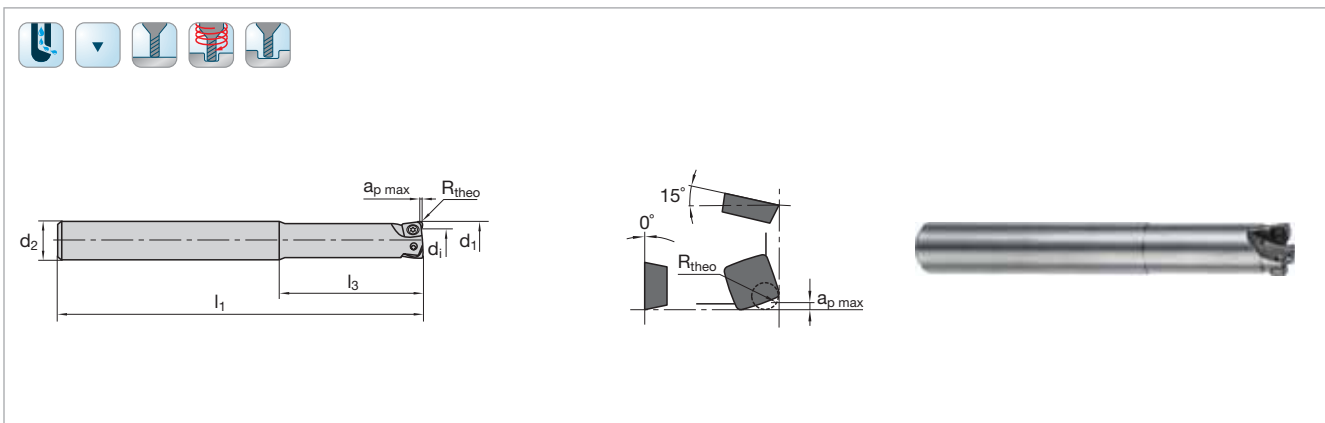

Katalog-Nr. Cat.-No.										ECP V07 IK <sup>1)</sup>			
d <sub>1</sub>	d <sub>i</sub>	l <sub>3</sub>	l <sub>1</sub>	d <sub>2</sub>	z	a <sub>p max</sub>	R <sub>theo</sub>	Ident No.	LMT-Code				
20	6,9	60	175	20	2	1	1,5	7028512	ECP V07.20AN175-I	XCNT 070308 SN-TR XCNT 070308 SN	9199156	1048326 T8	
25	12	75	190	25	3	1	1,5	7028513	ECP V07.25AN190-I				
32	19	80	210	32	3	1	1,5	7028514	ECP V07.32AN210-I				
32	19	80	210	32	4	1	1,5	7028515	ECP V07.32AN210-IF				

<sup>1)</sup> Fräser auch verfügbar in Zoll  
Cutters also available in inch

Schnittwertempfehlungen siehe Seite 23  
Cutting data recommendations see page 23

## MultiEdge 4Feed Aufschraubfräser MultiEdge 4Feed Screw-on type end mills

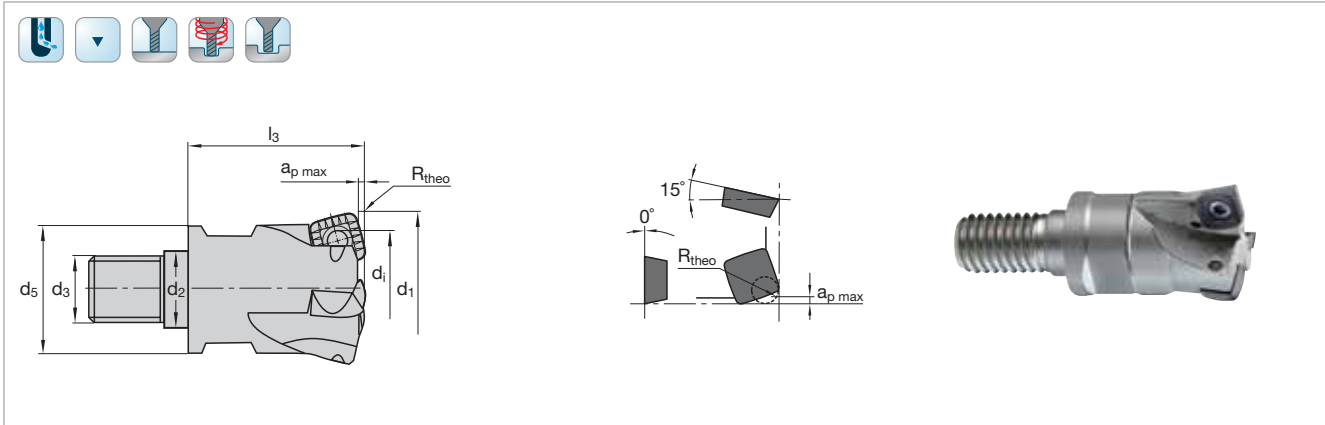

Katalog-Nr. Cat.-No.										ECP V09 IK <sup>1)</sup>				
d <sub>1</sub>	d <sub>i</sub>	l <sub>3</sub>	d <sub>3</sub>	d <sub>5</sub>	d <sub>2</sub>	z	a <sub>p max</sub>	R <sub>theo</sub>	Ident No.	LMT-Code				
32	17	43	M16	29	17	3	1,2	2,5	7028490	ECP V09.032TH043-I	XCNT 09T912 SN-TR	1045105	1048335 T15	
32	17	43	M16	29	17	4	1,2	2,5	7028491	ECP V09.032TH043-IF				XCNW 09T312 SN
35	20	43	M16	29	17	4	1,2	2,5	7028492	ECP V09.035TH043-I				
42	27	43	M16	29	17	4	1,2	2,5	7028493	ECP V09.042TH043-IW				
42	27	43	M16	29	17	5	1,2	2,5	7028494	ECP V09.042TH043-I				

<sup>1)</sup> Fräser auch verfügbar in Zoll  
Cutters also available in inch

## MultiEdge 4Feed Schaftfräser MultiEdge 4Feed end mills

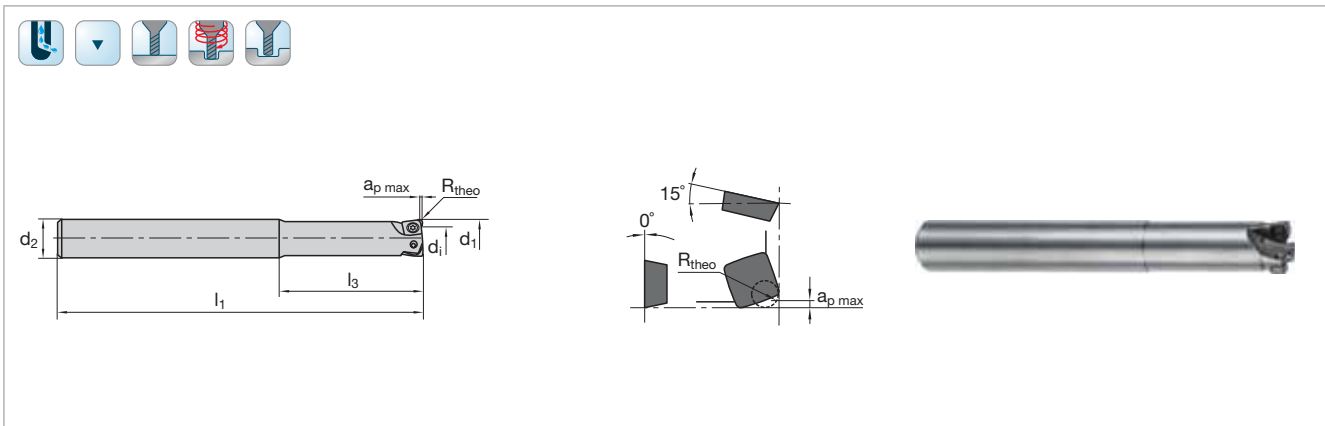

Katalog-Nr. Cat.-No.										ECP V09 IK <sup>1)</sup>			
d <sub>1</sub>	d <sub>i</sub>	l <sub>3</sub>	l <sub>1</sub>	d <sub>2</sub>	z	a <sub>p max</sub>	R <sub>theo</sub>	Ident No.	LMT-Code				
32	17	80	210	32	3	1,2	2,5	7028516	ECP V09.32AN210-I	XCNT 09T912 SN-TR	1045105	1048335 T15	
32	17	80	210	32	4	1,2	2,5	7028517	ECP V09.32AN210-IF				XCNW 09T312 SN

<sup>1)</sup> Fräser auch verfügbar in Zoll  
Cutters also available in inch

Schnittwertempfehlungen siehe Seite 23  
Cutting data recommendations see page 23

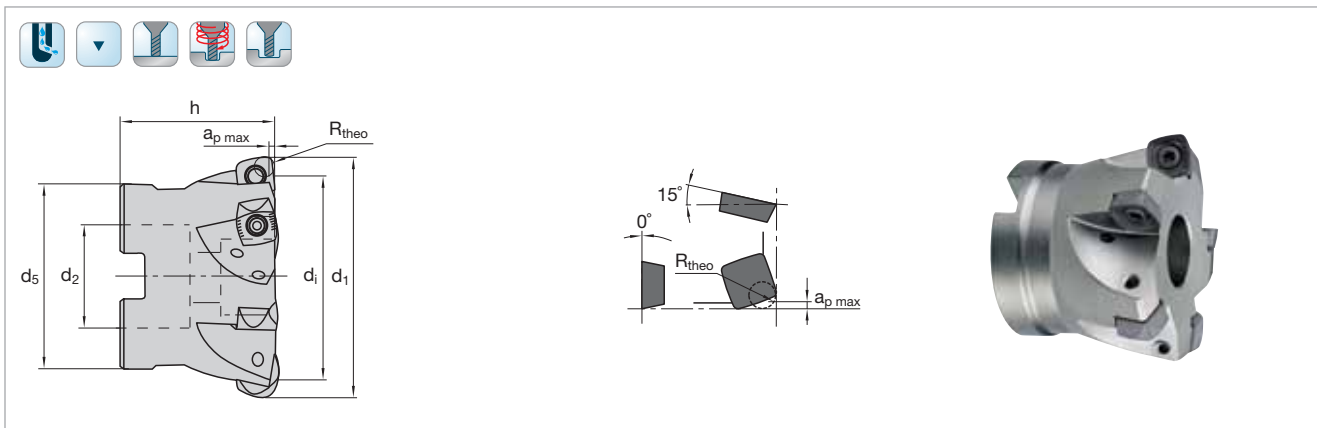

Katalog-Nr. Cat.-No.									FCP				
d <sub>1</sub>	d <sub>i</sub>	h	d <sub>5</sub>	d <sub>2</sub>	z	a <sub>p max</sub>	R <sub>theo</sub>	Ident No.	LMT-Code				
<b>FCP V09 IK<sup>1)</sup></b>													
42	27	40	32	16	3	1,2	2,5	7028495	FCP V09.042AN-IX	XCNT 09T312 SN-TR XCNW 09T312 SN	1045114	1048335 T15	
42	27	40	32	16	4	1,2	2,5	7028497	FCP V09.042AN-IW				
42	27	40	32	16	5	1,2	2,5	7028496	FCP V09.042AN-I				
52	37	40	40	22	4	1,2	2,5	7028498	FCP V09.052AN-IX				
52	37	40	40	22	5	1,2	2,5	7028499	FCP V09.052AN-IW				
52	37	40	40	22	6	1,2	2,5	7028500	FCP V09.052AN-I				
<b>FCP V12 IK<sup>1)</sup></b>													
42	23	40	32	16	3	1,5	3,5	7028501	FCP V12.042AN-IW	XCNT 120520 SN XCNW 120520 SN	1045123	1048344 T20	
42	23	40	32	16	4	1,5	3,5	7028502	FCP V12.042AN-I				
52	33,1	40	40	22	4	1,5	3,5	7028503	FCP V12.052AN-IW				
52	33,1	40	40	22	5	1,5	3,5	7028504	FCP V12.052AN-I				
66	47,1	50	50	27	5	1,5	3,5	7028505	FCP V12.066AN-IX				
66	47,1	50	50	27	6	1,5	3,5	7028506	FCP V12.066AN-IW				
66	47,1	50	50	27	7	1,5	3,5	7028507	FCP V12.066AN-I				
80	61,2	50	60	27	6	1,5	3,5	7028508	FCP V12.080AN-IW				
80	61,2	50	60	27	8	1,5	3,5	7028509	FCP V12.080AN-I				
100	81,2	50	65	32	7	1,5	3,5	7028510	FCP V12.100AN-IW				
100	81,2	50	65	32	10	1,5	3,5	7028511	FCP V12.100AN-I				

<sup>1)</sup> Fräser auch verfügbar in Zoll  
Cutters also available in inch

Schnittwertempfehlungen siehe Seite 23  
Cutting data recommendations see page 23

							Schneidstoffsorten Cutting materials Ident No.	
N = Anzahl der Schneidkanten N = Number of cutting edges	LMT-Code	l	d	s	d <sub>1</sub>	r	NEW LCK10M	Für Fräser For cutter  Cat-No.
<p>N = 4</p>	XCNT 070308 SN-TR	7,94	7,94	3,18	3,4	0,8		7047949
<p>N = 4</p>	XCNW 070308 SN	7,94	7,94	3,18	3,4	0,8	7047952	ECP IK
								P
								M
								K
								N
								S
								H

■ = Hauptanwendung First choice

							Schneidstoffsorten Cutting materials Ident No.	Für Fräser For cutter  Cat-No.
N = Anzahl der Schneidkanten N = Number of cutting edges	LMT-Code	l	d	s	d <sub>1</sub>	r	LCK10M	
<p>N = 4</p>	XCNT 09T312 SN-TR	9,52	9,52	3,97	3,8	1,2	7047950	ECP IK
	<p>N = 4</p>	XCNW 09T312 SN	9,52	9,52	3,97	3,8	1,2	7047353
								P
								M
							■	K
								N
								S
								H

■ = Hauptanwendung First choice

							Schneidstoffsorten Cutting materials Ident No.	
N = Anzahl der Schneidkanten N = Number of cutting edges	LMT-Code	l	d	s	d <sub>1</sub>	r	LCK10M	Für Fräser For cutter
								Cat-No.
<p>N = 4</p>	XCNT 120520 SN-TR	12,7	12,7	5,56	5,2	2,0	7047951	ECP IK
	<b>NEW</b>							
<p>N = 4</p>	XCNW 120520 SN	12,7	12,7	5,56	5,2	2,0	7047954	ECP IK
								M
■								K
								N
								S
								H

■ = Hauptanwendung First choice

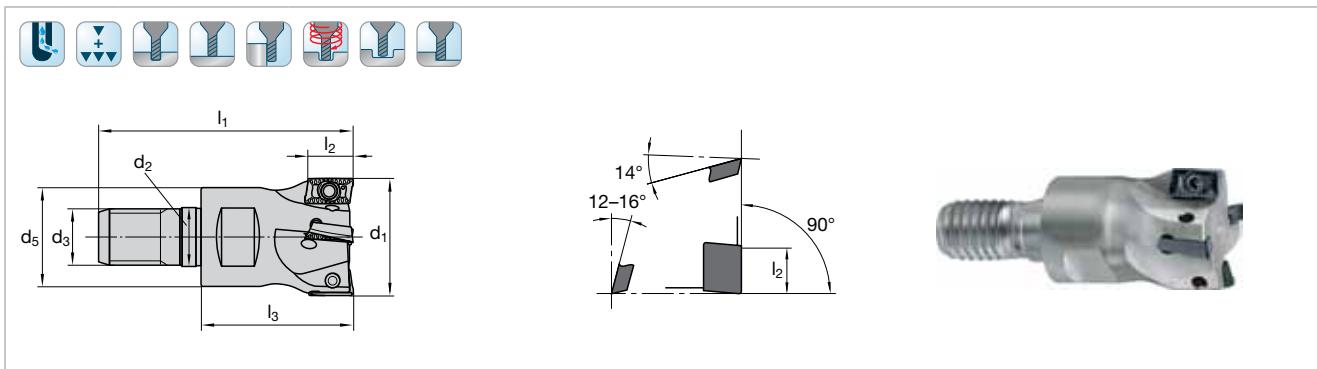

Katalog-Nr. Cat.-No.									EMU90 IK			
d <sub>1</sub>	l <sub>2</sub>	l <sub>1</sub>	l <sub>3</sub>	d <sub>5</sub>	d <sub>3</sub>	d <sub>2</sub>	z	Ident No.	LMT-Code			
20	8,5	49	30	18	M10	10,5	3	7012585	EMU90 A09.020TS-I	ADKX 09...	2127640	T08 1048326
25	8,5	55	33	21	M12	12,5	4	7012586	EMU90 A09.025TF-I			
32	8,5	67	43	29	M16	17	6	7012587	EMU90 A09.032TH-I			

Univex Premium Schafffräser 90°  
Univex Premium end mills 90°

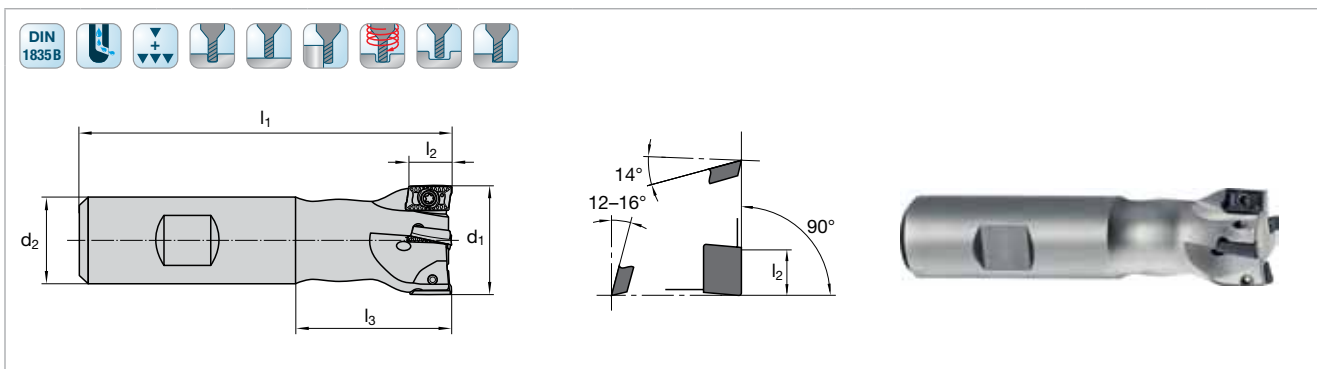

Katalog-Nr. Cat.-No.								EMU90 IK			
d <sub>1</sub>	l <sub>2</sub>	l <sub>1</sub>	l <sub>3</sub>	d <sub>2</sub>	z	Ident No.	LMT-Code				
16	8,5	76	28	16	2	1045071	EMU90 A09.016BN-I	ADKX 09...	2127640	T08 1048326	
20	8,5	86	36	20	3	1045072	EMU90 A09.020BN-I				
20	8,5	86	36	20	4	1045073	EMU90 A09.020BN-IF				
25	8,5	86	36	20	4	1045074	EMU90 A09.025BI-I				
25	8,5	86	36	20	5	1045075	EMU90 A09.025BI-IF				
32	8,5	86	40	25	6	1045076	EMU90 A09.032BG-I				

Schnittwertempfehlungen siehe Seite 24  
Cutting data recommendations see page 24

**Wendeschnidplatten für Univex Premium Aufschraubfräser 90°  
und Schafffräser 90°**  
Indexable inserts for Univex Premium screw-on type end mills 90°  
and end mills 90°

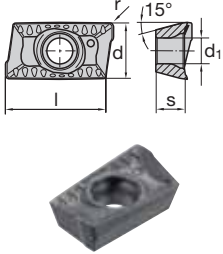
							Schneidstoffsorten Cutting materials Ident No.	Für Fräser For cutter  Cat-No.
N = Anzahl der Schneidkanten N = Number of cutting edges	LMT-Code	l	d	s	d <sub>1</sub>	r	<b>NEW</b>  LCK10M	
 N = 2	ADKX 090304 SR-TR	9,52	5,56	3,18	2,8	0,4	7048189	EMU90 IK
	ADKX 090308 SR-TR	9,52	5,56	3,18	2,8	0,8	7048190	
	ADKX 090312 SR-TR	9,52	5,56	3,18	2,8	1,2	7048191	
	ADKX 090316 SR-TR	9,52	5,56	3,18	2,8	1,6	7048192	
								P
								M
							■	K
								N
								S
								H

■ = Hauptanwendung First choice



**Univex Premium Aufschraubschafffräser 90°**  
**Univex Premium screw-on type end mills 90°**



Katalog-Nr. Cat.-No.										EMU90 IK		
d <sub>1</sub>	l <sub>2</sub>	l <sub>1</sub>	l <sub>3</sub>	d <sub>5</sub>	d <sub>3</sub>	d <sub>2</sub>	z	Ident No.	LMT-Code			
32	12	67	43	29	M16	17	4	7012588	EMU90 A12.032TH-I	ADKX 12...	2237513	T08 1048326
40	12	67	43	29	M16	17	6	7012589	EMU90 A12.040TH-I			

**Univex Premium Schafffräser 90°**  
**Univex Premium end mills 90°**

Katalog-Nr. Cat.-No.								EMU90 IK				
d <sub>1</sub>	l <sub>2</sub>	l <sub>1</sub>	l <sub>3</sub>	d <sub>2</sub>	z	Ident No.	LMT-Code					
20	12	86	36	20	2	1045090	EMU90 A12.020BN-I	ADKX 12...	2237513	T08 1048326		
25	12	86	36	20	3	1045092	EMU90 A12.025BI-I					
32	12	96	40	25	4	1045093	EMU90 A12.032BG-I					
32	12	96	40	25	5	1045094	EMU90 A12.032BG-IF					
40	12	110	50	32	6	1045095	EMU90 A12.040BF-I					

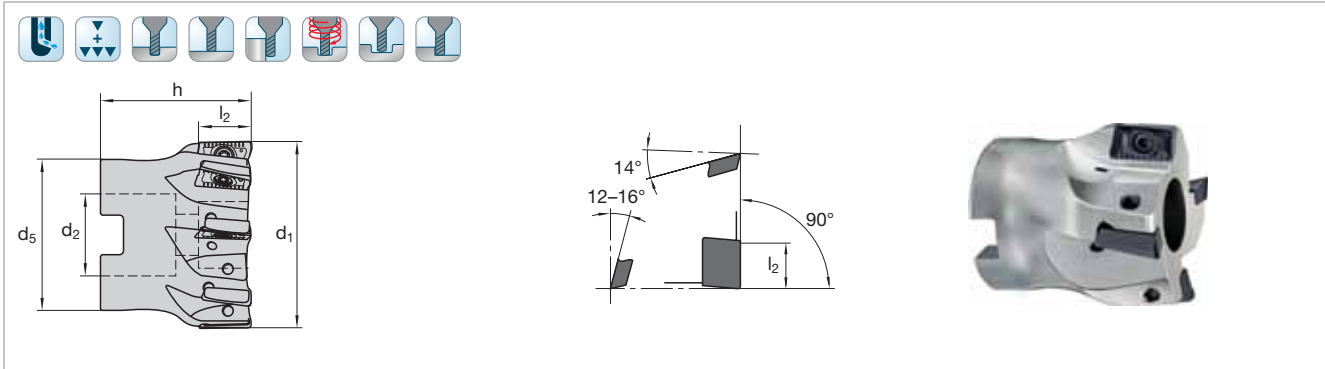
Schnittwertempfehlungen siehe Seite 24  
 Cutting data recommendations see page 24



Katalog-Nr. Cat.-No.							FMU90 IK			
d <sub>1</sub>	l <sub>2</sub>	h	d <sub>5</sub>	d <sub>2</sub>	z	Ident No.	LMT-Code			
40	12	40	32	16	4	1045100	FMU90 A12.040AN-IW	ADKX 12...	2237513	T08 1048326
40	12	40	32	16	6	1045101	FMU90 A12.040AN-I			
50	12	40	40	22	5	1045102	FMU90 A12.050AN-IW			
50	12	40	40	22	7	1045103	FMU90 A12.050AN-I			
63	12	40	50	22	6	1045104	FMU90 A12.063AN-IW			
63	12	40	50	22	9	1045106	FMU90 A12.063AN-I			

Schnittwertempfehlungen siehe Seite 24  
Cutting data recommendations see page 24

							Schneidstoffsorten Cutting materials Ident No.	
N = Anzahl der Schneidkanten N = Number of cutting edges	LMT-Code	l	d	s	d <sub>1</sub>	r	LCK10M	Für Fräser For cutter
								Cat-No.
 N = 2	ADKX 120408 SR-TR	12,7	7,4	4,76	3,4	0,8	7048193	FMU90 IK
	ADKX 120412 SR-TR	12,7	7,4	4,76	3,4	1,2	7048194	
	ADKX 120416 SR-TR	12,7	7,4	4,76	3,4	1,6	7048195	
	ADKX 120420 SR-TR	12,7	7,4	4,76	3,4	2	7048196	
								P
								M
							■	K
								N
								S
								H

■ = Hauptanwendung First choice

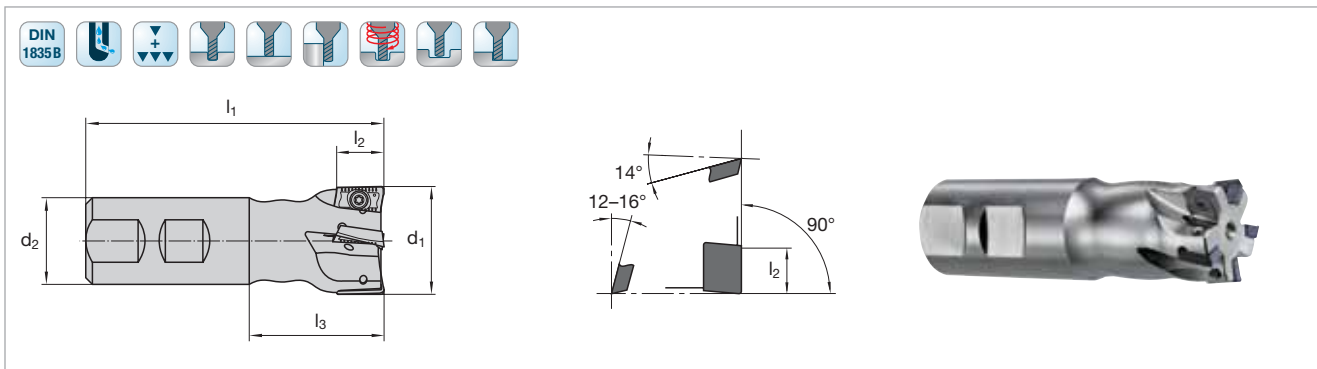

Katalog-Nr. Cat.-No.							EMU90 IK			
d <sub>1</sub>	l <sub>2</sub>	l <sub>1</sub>	l <sub>3</sub>	d <sub>2</sub>	z	Ident No.	LMT-Code			
25	16,5	96	40	25	2	1045050	EMU90 A17.025BN-IF	ADKX 17...	1045105	T15
32	16,5	110	50	32	3	1045053	EMU90 A17.032BN-IF		1045114	1048335
40	16,5	110	50	32	4	1045054	EMU90 A17.040BF-IF			

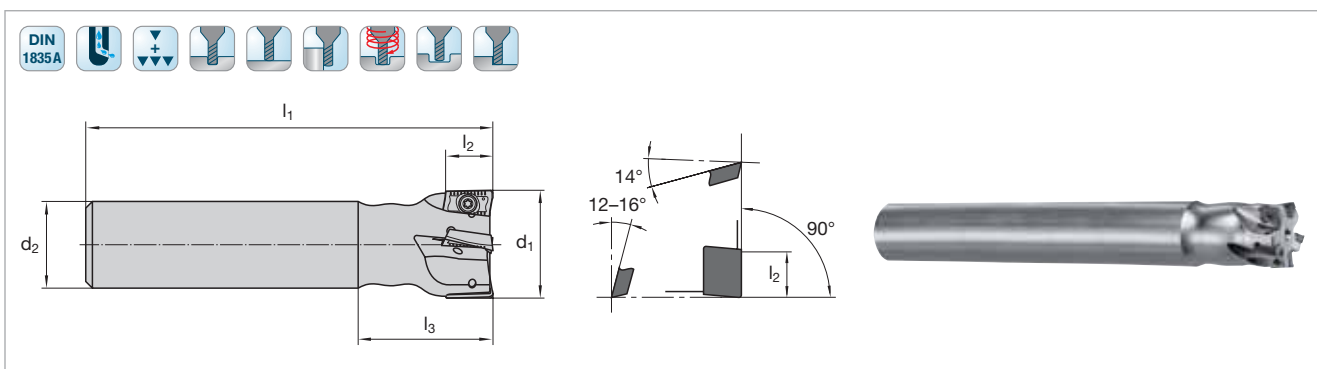

Univex Premium Schaftfräser 90°, extra lang  
Univex Premium end mills 90°, extra long

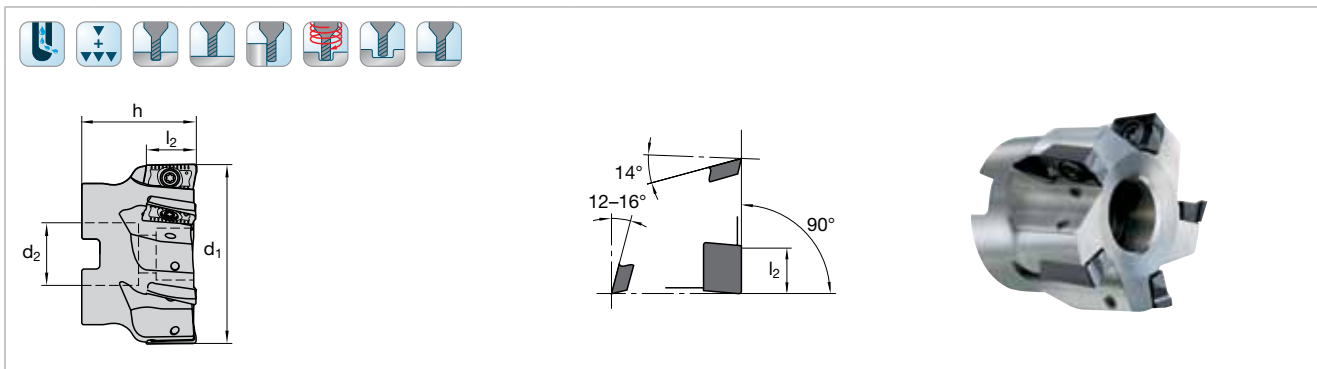

Katalog-Nr. Cat.-No.							EMU90 IK			
d <sub>1</sub>	l <sub>2</sub>	l <sub>1</sub>	l <sub>3</sub>	d <sub>2</sub>	z	Ident No.	LMT-Code			
25	16,5	200	40	25	2	1045043	EMU90 A17.025AN-IF	ADKX 17...	1045105	T15
32	16,5	250	50	32	3	1045044	EMU90 A17.032AN-IF		1045114	1048335
40	16,5	250	50	32	4	1045045	EMU90 A17.040AF-IF			

Schnittwertempfehlungen siehe Seite 24  
Cutting data recommendations see page 24



Katalog-Nr. Cat.-No.						FMU90 IK			
d <sub>1</sub>	l <sub>2</sub>	h	d <sub>2</sub>	z	Ident No.	LMT-Code			
40	16,5	36	16	4	1045035	FMU90 A17.040AN-IF	ADKX 17...	1045114	T15 1048335
50	16,5	40	22	5	1045036	FMU90 A17.050AN-IF			
63	16,5	40	22	6	1045037	FMU90 A17.063AN-IF			
80	16,5	50	27	8	1045038	FMU90 A17.080AN-IF			
100	16,5	50	32	9	1045039	FMU90 A17.100AN-IF			

Schnittwertempfehlungen siehe Seite 24  
Cutting data recommendations see page 24

**Wendeschneidplatten für Univex Premium Schafffräser 90° und Schafffräser 90°, extra lang**  
**Indexable inserts for Univex Premium end mills 90° and end mills 90°, extra long**

							Schneidstoffsorten Cutting materials Ident No.	Für Fräser For cutter  Cat-No.
N = Anzahl der Schneidkanten N = Number of cutting edges	LMT-Code	l	d	s	d <sub>1</sub>	r	<b>NEW</b> LCK10M	
<p>N = 2</p>	ADKX 170508 SR-TR	17,5	9,62	5,6	3,8	0,8	7048197	EMU90 IK
	ADKX 170512 SR-TR	17,5	9,62	5,6	3,8	1,2	7048198	
	ADKX 170516 SR-TR	17,5	9,62	5,6	3,8	1,6	7048199	
	ADKX 170520 SR-TR	17,5	9,62	5,6	3,8	2	7048200	
								P
								M
							■	K
								N
								S
								H

■ = Hauptanwendung First choice

MultiEdge Double 8

Werkstoff Material	Werkstoff-Nr. Material No.	DIN Bezeichnung DIN Description	R <sub>m</sub> /UTS (N/mm <sup>2</sup> )	Kühlung Cooling	Schnittgeschw. Cutting speed v <sub>c</sub> (m/min)	Empfohlene maximale Zahnvorschübe Recommended max. feed per tooth f <sub>z</sub> (mm) bei with a <sub>e</sub> = 0,75 x d <sub>1</sub>		
						LCK10M		
						ONGU 0505	ONGU 0606	
						f <sub>z</sub>	f <sub>z</sub>	
K Gusseisen mit Lamellengraphit Cast iron with flake graphite	EN-JL-1040 (0.6025)	EN-GJL-250 (GG 25)	120–260 HB		240–340	0,35	0,40	
	Gusseisen mit Kugelgraphit Cast iron with nodular graphite	EN-JS-1030 (0.7040)	EN-GJS-400 (GGG 40)	135–180 HB		200–280	0,35	0,40
		EN-JS-1060 (0.7060)	EN-GJS-600 (GGG 60)	190–270 HB		180–240	0,30	0,35
Temperguss Malleable cast iron	EN-JM-1160 (0.8155)	EN-GJMB-550-4 (GTS 55)	150–280 HB					

MultiEdge 4Feed

Werkstoff Material	Werkstoff-Nr. Material No.	DIN Bezeichnung DIN Description	R <sub>m</sub> /UTS (N/mm <sup>2</sup> )	Kühlung Cooling	Schnittgeschw. Cutting speed v <sub>c</sub> (m/min)	Empfohlene max. Zahnvorschübe Recommended max. feed per tooth f <sub>z</sub> (mm) bei with a <sub>e</sub> = 0,75 x d <sub>1</sub> (d <sub>1</sub> = Fräserdurchmesser Cutter diameter)			
						LCK10M			
						XCNT07 SN-TR XCNW07 SN	XCNT09 SN-TR XCNW09 SN	XCNT12 SN-TR XCNW12 SN	
						f <sub>z</sub>	f <sub>z</sub>	f <sub>z</sub>	
K Gusseisen mit Lamellengraphit Cast iron with flake graphite	EN-JL-1040 (0.6025)	EN-GJL-250 (GG 25)	120–260 HB		260–340	1,50	2,00	2,50	
	Gusseisen mit Kugelgraphit Cast iron with nodular graphite	EN-JS-1030 (0.7040)	EN-GJS-400 (GGG 40)	135–180 HB		200–280	1,50	2,00	2,50
		EN-JS-1060 (0.7060)	EN-GJS-600 (GGG 60)	190–270 HB		180–240	1,00	1,20	1,40
Temperguss Malleable cast iron	EN-JM-1160 (0.8155)	EN-GJMB-550-4 (GTS 55)	150–280 HB						

MultiEdge FCT45

Werkstoff Material	Werkstoff-Nr. Material No.	DIN Bezeichnung DIN Description	R <sub>m</sub> /UTS (N/mm <sup>2</sup> )	Kühlung Cooling	Schnittgeschw. Cutting speed v <sub>c</sub> (m/min)	Empfohlene max. Zahnvorschübe Recommended max. feed per tooth f <sub>z</sub> (mm) bei with a <sub>e</sub> = 0,75 x d <sub>1</sub> (d <sub>1</sub> = Fräserdurchmesser Cutter diameter)				
						LCK10M				
						SAHT 1005 <sup>1)</sup> SAHT 1306 <sup>1)</sup>	OCKX 0505 OCKX 0606	RCKX 1205	RCKX 1606	
						f <sub>z</sub>	f <sub>z</sub>	f <sub>z</sub>	f <sub>z</sub>	
K Gusseisen mit Lamellengraphit Cast iron with flake graphite	EN-JL-1040 (0.6025)	EN-GJL-250 (GG 25)	120–260 HB		260–340	0,40	0,50	0,40	0,50	
	Gusseisen mit Kugelgraphit Cast iron with nodular graphite	EN-JS-1030 (0.7040)	EN-GJS-400 (GGG 40)	135–180 HB		200–280	0,35	0,40	0,35	0,40
		EN-JS-1060 (0.7060)	EN-GJS-600 (GGG 60)	190–270 HB		180–240	0,35	0,40	0,35	0,40
Temperguss Malleable cast iron	EN-JM-1160 (0.8155)	EN-GJMB-550-4 (GTS 55)	150–280 HB							

<sup>1)</sup> Bei der SAHT 1005 auf a<sub>p</sub> = 2 mm und bei der SAHT 1306 auf a<sub>p</sub> = 3 mm For SAHT 1005 with a<sub>p</sub> = 2 mm and for SAHT 1306 with a<sub>p</sub> = 3 mm  
Die angegebenen Schnittwerte sind Startwerte und müssen auf die vorhandenen Bedingungen abgestimmt werden.  
The cutting data indicated are starting values and must be adjusted to the prevailing conditions.

Univex Premium

	Werkstoff Material	Werkstoff-Nr. Material No.	DIN Bezeichnung DIN Description	R <sub>m</sub> /UTS (N/mm <sup>2</sup> )	Kühlung Cooling	Schnittgeschw. Cutting speed v <sub>c</sub> (m/min)	Empfohlene max. Zahnvorschübe Recommended max. feed per tooth f <sub>z</sub> (mm) bei with a <sub>e</sub> = 0,75 x d <sub>1</sub> (d <sub>1</sub> = Fräserdurchmesser Cutter diameter)		
							LCK10M		
							ADKX 0903	ADKX 1204	ADKX 1705
K	Gusseisen mit Lamellengraphit Cast iron with flake graphite	EN-JL-1040 (0.6025)	EN-GJL-250 (GG 25)	120–260 HB		240–300	0,20	0,25	0,35
	Gusseisen mit Kugelgraphit Cast iron with nodular graphite	EN-JS-130 (0.7040)	EN-GJS-400 (GGG 40)	135–180 HB			180–240	0,15	0,22
		EN-JS-1060 (0.7060)	EN-GJS-600 (GGG 60)	190–270 HB	160–200		0,12	0,20	0,3
	Temperguss Malleable cast iron	EN-JM-1160 (0.8155)	EN-GJMB-550-4 (GTS 55)	150–280 HB					

Die angegebenen Schnittwerte sind Startwerte und müssen auf die vorhandenen Bedingungen abgestimmt werden.  
The cutting data indicated are starting values and must be adjusted to the prevailing conditions.

Berechnungsformeln Calculating formulas		
<b>Drehzahl Speed n (min<sup>-1</sup>):</b> $n = \frac{v_c \cdot 1000}{\pi \cdot d_1}$	<b>Schnittgeschwindigkeit Cutting speed</b> $v_c = \frac{n \cdot \pi \cdot d_1}{1000}$	v <sub>c</sub> = Schnittgeschwindigkeit Cutting speed (m/min) n = Drehzahl Speed (min <sup>-1</sup> ) d <sub>1</sub> = Fräser-Durchmesser Cutter dia. (mm) v <sub>f</sub> = Vorschubgeschwindigkeit Feed rate (mm/min) f <sub>z</sub> = Vorschub pro Zahn Feed per tooth (mm) P <sub>e</sub> = Antriebsleistung Drive power (kW) z <sub>eff</sub> = effektive Zähnezahle Effective number of teeth f <sub>2</sub> = Korrekturfaktor für v <sub>f</sub> Correction factor Q = Spanvolumen Chip volume (cm <sup>3</sup> /min) a <sub>e</sub> = Schnittbreite Width of cut (mm) a <sub>p</sub> = Schnitttiefe Depth of cut (mm) LF = Leistungsfaktor Efficiency factor (cm <sup>3</sup> /min/kW)
<b>Vorschubgeschwindigkeit Feed rate v<sub>f</sub> (mm/min):</b> v <sub>f</sub> = f <sub>z</sub> · z <sub>eff</sub> · n · f <sub>2</sub>	<b>Vorschub pro Zahn Feed per tooth</b> $f_z = \frac{v_f}{z_{eff} \cdot n \cdot f_2}$	
<b>Spanvolumen Chip volume-Q (cm<sup>3</sup>/min):</b> $Q = \frac{a_e \cdot a_p \cdot v_f}{1000}$	<b>Antriebsleistung Drive power</b> $P_e = \frac{Q}{LF}$	

Vorschub-Korrektur Feed correction			
v <sub>f</sub> = f <sub>z</sub> · z · n · f <sub>2</sub>	a <sub>p</sub>	f <sub>2</sub>	
		l <sub>ges.</sub> < 4 x d <sub>1</sub>	f <sub>2</sub> l <sub>ges.</sub> > 4 x d <sub>1</sub>
	0,5 x a <sub>p max</sub>	1,3	1,0
	0,75 x a <sub>p max</sub>	1,0	0,75
	1,0 x a <sub>p max</sub>	0,7	0,5





**Maschinenbau, Pumpengehäuse**  
Machine construction, Pump unit

**Werkzeug Tool:**

Univex Premium Eckfräser 90°  
Univex Premium Face Mill 90°  
FMU90,  $d_1 = 50$ ,  $z = 5$

**Wendeplatte Insert:**

ADKX 170512 SR-TR, LCK10M

**Werkstoff Material:**

EN-GJL-250 (GG25)

**Schnittwerte Cutting data:**

$v_c = 290$  m/min  
 $n = 1850$  min<sup>-1</sup>  
 $f_z = 0,25$  mm  
 $v_f = 2300$  mm/min  
 $a_e = 35$  mm  
 $a_p = 15$  mm

**Kühlung Coolant:**

trocken dry



**Maschinenbau, Spindelgehäuse**  
Machine construction, Spindle housing

**Werkzeug Tool:**

MultiEdge Planfräskopf  
MultiEdge Face Cutter  
FCT45,  $d_1 = 100$ ,  $z = 7$

**Wendeplatte Insert:**

OCKX 0606 Ad-TR, LCK10M

**Werkstoff Material:**

EN-GJS-400 (GGG40)

**Schnittwerte Cutting data:**

$v_c = 240$  m/min  
 $n = 760$  min<sup>-1</sup>  
 $f_z = 0,3$  mm  
 $v_f = 1600$  mm/min  
 $a_e = 75$  mm  
 $a_p = 2,5$  mm

**Kühlung Coolant:**

trocken dry



**Maschinenbau, Getriebegehäuse**  
Machine construction, Gear housing

**Werkzeug Tool:**  
MultiEdge Planfräskopf  
MultiEdge Face Cutter  
FCT45,  $d_1 = 80$ ,  $z = 7$

**Wendeplatte Insert:**  
OCKX 0505 AD-TR, LCK10M

**Werkstoff Material:**  
EN-GJL-250 (GG25)

**Schnittwerte Cutting data:**

$v_c = 360$  m/min  
 $n = 1430$  min<sup>-1</sup>  
 $f_z = 0,18$  mm  
 $v_f = 1800$  mm/min  
 $a_e = 55$  mm  
 $a_p = 0,8$  mm

**Kühlung Coolant:**  
trocken dry



**Maschinenbau, Gehäuseoberteil Rundläuferpresse**  
Machine construction, Rotary press housing top

**Werkzeug Tool:**  
MultiEdge Double 8  
MultiEdge Double 8  
FMN45,  $d_1 = 125$ ,  $z = 15$

**Wendeplatte Insert:**  
ONGU 0606 ANEN, LCK10M

**Werkstoff Material:**  
EN-GJS-400 (GGG40)

**Schnittwerte Cutting data:**









$v_c = 230$  m/min  
 $n = 590$  min<sup>-1</sup>  
 $f_z = 0,28$  mm  
 $v_f = 2500$  mm/min  
 $a_e = 105$  mm  
 $a_p = 3$  mm

**Kühlung Coolant:**  
trocken dry



**Normen für Schäfte und Schneiden**  
Standards for shanks and cutting edges

DIN  
1835B

**Prozesse**  
Processes

-  **Schruppen**  
Roughing
-  **Schruppen + Schlichten**  
Roughing + Finishing
-  **Planfräsen**  
Face milling
-  **Kopierfräsen**  
Copying
-  **Eckfräsen**  
Corner milling
-  **Außenkonturfräsen**  
Contour milling
-  **Nutenfräsen**  
Slotting
-  **Taschenfräsen**  
Pocket milling
-  **Zirkularfräsen**  
Circular milling

**Besonderheiten**  
Special features

-  **Innenkühlung mit seitl. Austritt**  
Internal cooling with side outlet
-  **Trockenbearbeitung**  
Dry machining
-  **Nassbearbeitung**  
Wet machining

© by LMT Fette Werkzeugtechnik GmbH & Co. KG

Nachdruck, auch auszugsweise, ist nur mit unserer Zustimmung gestattet. Alle Rechte vorbehalten. Irrtümer, Satz- oder Druckfehler berechtigen nicht zu irgendwelchen Ansprüchen. Abbildungen, Ausführungen und Maße entsprechen dem neuesten Stand bei Herausgabe dieser Druckschrift. Technische Änderungen müssen vorbehalten sein. Die bildliche Darstellung der Produkte muss nicht in jedem Falle und in allen Einzelheiten dem tatsächlichen Aussehen entsprechen.

This publication may not be reprinted in whole or part without our express permission. All right reserved. No rights may be derived from any errors in content or from typographical or typesetting errors. Diagrams, features and dimensions represent the current status on the date of issue of this leaflets. We reserve the right to make technical changes. The visual appearance of the products may not necessarily correspond to the actual appearance in all cases or in every detail.

**Brasilien / Brazil**

LMT Boehlerit Ltda.  
Alameda Caiapós, 693  
Centro Empresarial  
Tamboré  
06460-110 – Barueri  
São Paulo  
Telefon +55 11 55460755  
Telefax +55 11 55460476  
lmtvendas@lmt.com.br

**China**

LMT China Co. Ltd.  
No. 8 Phoenix Road,  
Jiangning Development Zone  
211100 Nanjing  
Telefon +86 25 52128866  
Telefax +86 25 52106376  
lmt.cn@lmt-tools.com

**Deutschland / Germany**

LMT Tool Systems GmbH  
Heidenheimer Str. 84  
73447 Oberkochen  
Telefon +49 7364 9579-0  
Telefax +49 7364 9579-8000  
lmt.de@lmt-tools.com

**Frankreich / France**

LMT Belin France S.A.S.  
01590 Lavancia  
Telefon +33 474 758989  
Telefax +33 474 758990  
lmt.fr@lmt-tools.com

**Großbritannien und Irland /  
United Kingdom**

LMT UK Ltd.  
5 Elm Court  
Copse Drive  
Meriden  
CV5 9RG  
Telefon +44 1676 523440  
Telefax +44 1676 525379  
lmt.uk@lmt-tools.com

**LMT Belin France S.A.S.**

01590 Lavancia  
Frankreich  
Telefon +33 474 758989  
Telefax +33 474 758990  
info@lmt-belin.com  
www.lmt-belin.com

**LMT Fette Werkzeugtechnik  
GmbH & Co. KG**

Grabauer Straße 24  
21493 Schwarzenbek  
Deutschland  
Telefon +49 4151 12-0  
Telefax +49 4151 3797  
info@lmt-fette.com  
www.lmt-fette.com

**Indien / India**

LMT (India) Private Limited  
Old No. 14, New No. 29,  
IInd Main Road  
Gandhinagar, Adyar  
Chennai – 600 020  
Telefon +91 44 24405136/137  
+91 44 42337701/03  
Telefax +91 42337704  
lmt.in@lmt-tools.com

**Italien / Italy**

LMT ITALY S.r.l.  
Via Bruno Buozzi 31  
20090 Segrate (MI)  
Telefon +39 02 2694971  
Telefax +39 02 21872422  
lmt.it@lmt-tools.com

**Kanada / Canada**

LMT USA Inc.  
1081 S. Northpoint Blvd.  
Waukegan, IL 60085  
Telefon +1 847 6933270  
Telefax +1 847 6933271  
lmt.us@lmt-tools.com

**Korea**

LMT Korea Co. Ltd.  
Room #1212, Anyang Trade  
Center  
1107 Bisan-Dong, Dongan-Gu,  
Anyang-Si,  
Gyeonggi-Do, 431-817,  
South Korea  
Telefon +82 31 3848600  
Telefax +82 31 3842121  
lmt.kr@lmt-tools.com

**LMT Kieninger GmbH**

Vogesenstraße 23  
77933 Lahr  
Deutschland  
Telefon +49 7821 943-0  
Telefax +49 7821 943213  
info@lmt-kieninger.com  
www.lmt-kieninger.com

**LMT Onsrud LP**

1081 S. Northpoint Blvd.  
Waukegan, IL 60085  
USA  
Telefon +1 847 3621560  
Telefax +1 847 4731934  
info@lmt-onsrud.com  
www.lmt-onsrud.com

**Mexiko / Mexico**

LMT Boehlerit S.A. de C.V.  
Ave. Acueducto No. 15  
Parque Industrial  
Bernardo Quintana  
76246 El Marqués, Querétaro  
Telefon +52 442 2215706  
Telefax +52 442 2215555  
info@lmt.com.mx

**Österreich / Austria**

Boehlerit GmbH & Co. KG  
Werk-VI-Straße  
8605 Kapfenberg  
Telefon +43 3862 300-0  
Telefax +43 3862 300793  
info@boehlerit.com

**Polen / Poland**

LMT Boehlerit Polska Sp. z o.o.  
ul. Wysogotowska 9  
62-081 Przemierowo  
Telefon +48 61 6512030  
Telefax +48 61 6232014  
lmt@lmt-polska.pl

**Rußland / Russia**

OOO LMT Tools  
Kotlyakowskaya str. 3  
115201 Moscow  
Telefon +7 495 510-1027  
Telefax +7 495 510-1028  
info@lmt-russia.ru

**Singapur / Singapore**

LMT Asia PTE LTD.  
1 Clementi Loop 04-01  
Clementi West District Park  
Singapur 12 9808  
Telefon +65 64 624214  
Telefax +65 64 624215  
sales@lmta.com.sg

in alliance

**Spanien und Portugal /  
Spain and Portugal**

LMT Boehlerit S.L.  
C/. Narcis Monturiol 11-15  
08339 Vilassar de Dalt  
Barcelona  
Telefon +34 93 7507907  
Telefax +34 93 7507925  
lmt.es@lmt-tools.com

**Tschechische Republik  
und Slowakei /  
Czech Republic and Slovakia**

LMT Czech Republic s.r.o.  
Dusikova 3  
63800 Brno-Lesná  
Telefon +420 548 218722  
Telefax +420 548 218723  
lmt.fette@iol.cz

**Türkei / Turkey**

BÖHLER Sert Maden  
ve Takim Sanayi ve Ticaret A.Ş.  
Ankara Asfaltı Üzeri No. 22,  
Kartal 34873  
Istanbul  
Telefon +90 216 306 65 70  
Telefax +90 216 306 65 74  
bohler@bohler.com.tr

**Ungarn / Hungary**

LMT-Boehlerit Kft  
Kis-Duna U. 6  
2030 Erd  
Po Box # 2036 Erdliget Pf. 32  
Telefon +36 23 521910  
Telefax +36 23 521919  
lmt.hu@lmt-tools.com

**USA**

LMT USA Inc.  
1081 S. Northpoint Blvd.  
Waukegan, IL 60085  
Telefon +1 847 6933270  
Telefax +1 847 6933271  
lmt.us@lmt-tools.com

**Bilz Werkzeugfabrik  
GmbH & Co. KG**

Vogelsangstraße 8  
73760 Ostfildern  
Deutschland  
Telefon +49 711 348010  
Telefax +49 711 3481256  
info@bilz.com  
www.bilz.com

**Boehlerit GmbH & Co. KG**

Werk-VI-Straße  
8605 Kapfenberg  
Österreich  
Telefon +43 3862 300-0  
Telefax +43 3862 300793  
info@boehlerit.com  
www.boehlerit.com

LMT Technology Group

**BELIN  
FETTE  
KIENINGER  
ONSRUD**

in alliance

**BILZ  
BOEHLERIT**