



WORKBENCHES
A system made to measure

According to individual needs and functions, ergonomic aspects or personal wishes, a workstation can be equipped with the Huni Italiana workbench system.

The unlimited diversity of the system, featuring numerous components in various sizes and variations, creates ideal prerequisites for clean, clearly arranged and efficient work.

Tools and smart parts can be tidily packed away at the workstation. Huni Italiana offers a complete programme of drawer cabinets with several drawers in various sizes and a wide selection of partitioning materials as well as an assortment of hooks, for various use, to be fixed into place with screws on the perforated panels. Beside the bench, under the bench or on the floor, drawer cabinets can be mounted according to preference and use.

WERKBÄNKE
Freie Auswahl im System

Ganz individuell nach Anforderung und Funktion, ergonomischen Aspekten oder persönlichen Wünschen, gestaltet sich ein Arbeitsplatz mit dem Huni Italiana Werkbanksystem.

Die fast unbegrenzte Systemvielfalt mit einer Vielzahl an Komponenten in verschiedensten Abmessungen und Ausführungsvarianten schafft ideale Voraussetzungen für sauberes, übersichtliches und rationelles Arbeiten. Werkzeuge und Kleinteile am Arbeitsplatz werden übersichtlich aufbewahrt. Dafür bietet Huni Italiana ein umfassendes Programm für Schubladenschränke mit vielen Schubladengrößen und einem breiten Sortiment an Einteilungsmaterial. Neben dem Tisch, unter dem Tisch oder bodenstehend, ganz nach Wunsch und Einsatz, wird der Schubladenschrank montiert.





WORKBENCHES

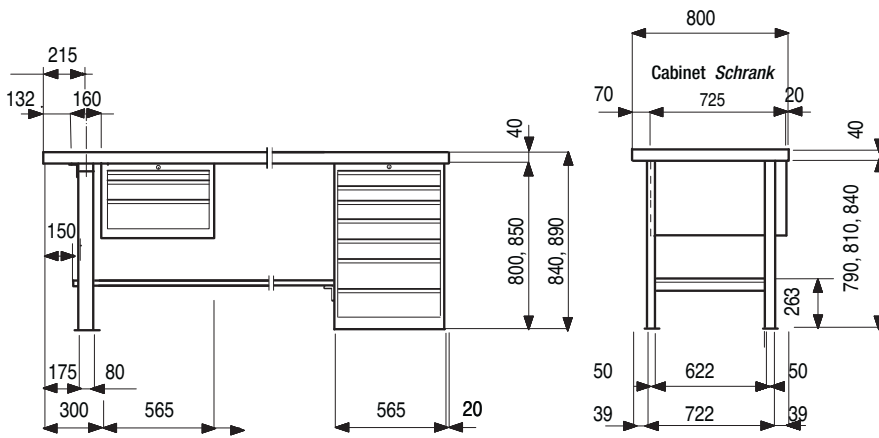

Workbenches dimensions
Maße von Werkbänken

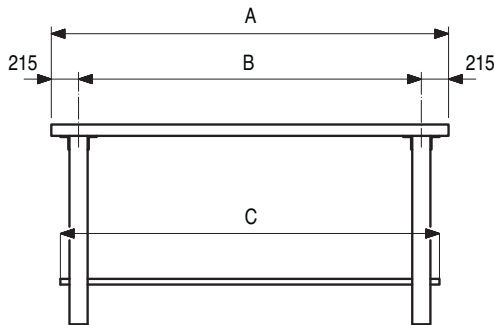

Locating distances of the workbench top
Auflagemaß der Platten

A mm	B mm	C mm
1500	1070	1200
1750	1320	1450
2000	1570	1700

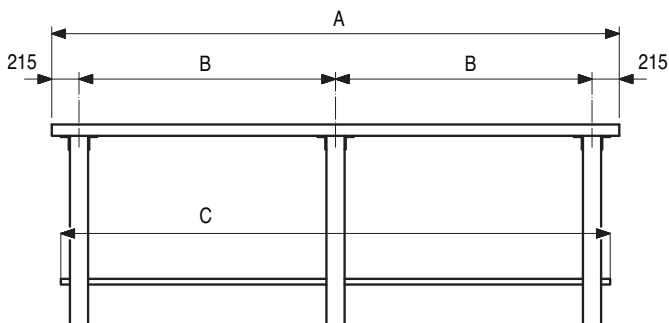

A mm	B mm	C mm
2500	1035	2200
3000	1285	2700

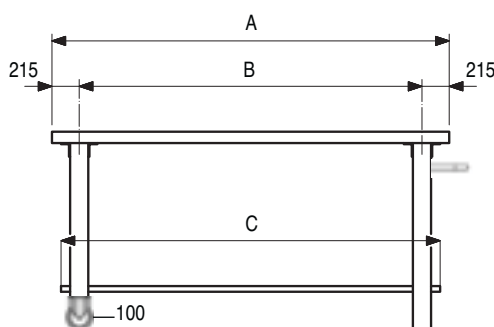

A mm	B mm	C mm
1500	1070	1200
1750	1320	1450
2000	1570	1700

■ **Wooden tops, 40 mm thick**

■ **Holzplatten, 40 mm stark**

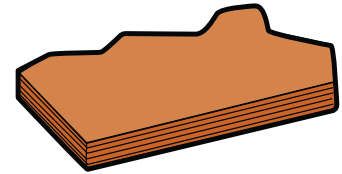

Lenght <i>Länge</i> mm	Depth without rear panel <i>Tiefe ohne Rückwand</i> mm	Rear panel height <i>Höhe der Rückwand</i> mm	Code <i>Bestell-Nr.</i>
1500	800	-	827.404
		60	827.405
1750	800	-	827.407
		60	827.453
2000	800	-	827.409
		60	827.410
2500*	800	-	827.412
		60	827.454
3000*	800	-	827.414
		60	827.455

* 3 supports points are necessary

* 3 Auflagen notwendig

■ **Bench legs**

■ **Werkbankfüße**

Steel sheet construction, powder coated according to the colour chart. Upper support with 6 holes for fastening of wooden top. Drilled base plates for floor anchoring.

Stahlkonstruktion, pulverbeschichtet und einbrennlackiert nach Farbkarte. Im oberen Träger gibt es 6 Schlitzlöcher für die Plattenbefestigung. In der Fussplatte gibt es ein Loch für die Bodenverankerung.

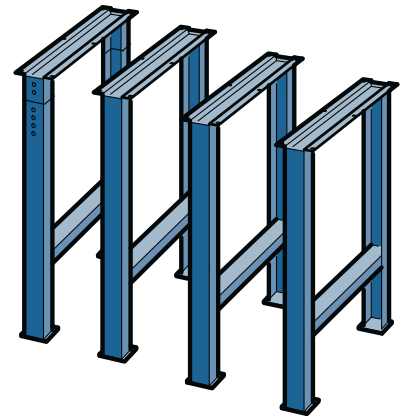

Height <i>Höhe</i> mm	Bench height <i>Werkbankhöhe</i>	Width <i>Breite</i> mm	Depth <i>Tiefe</i> mm	Code <i>Bestell-Nr.</i>
800	840	80	722	827.151
830	870	80	722	827.154
850	890	80	722	827.155
750-1050*	790-1090	80	722	827.180

* Adjustable every 25 mm

* Höhenverstellbar alle 25 mm

Fastening material without pre-assembling
Befestigungsmaterial, ohne Vormontage 827.552

Load capacity: 400 Kg

Tragfähigkeit: 400 Kg

■ **Bench legs on wheels**

■ **Werkbankfüße mit Rädern**

Steel sheet construction, powder coated according to the colour chart. Available with handle, with fixed and rotating wheels. Upper part with 6 buttonholes to fix at the wooden tops.

Stahlkonstruktion, pulverbeschichtet und einbrennlackiert nach Farbkarte. Halter verfügbar mit Stosgriff, festen und drehbaren Rädern. Obere Schnitt mit 6 Knopflöcher für die Verankerung der Werkbänke.

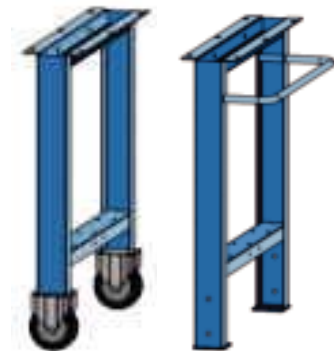

Naming <i>Bezeichnung</i>	Height <i>Höhe</i> mm	Depth <i>Tiefe</i> mm	Code <i>Bestell-Nr.</i>
Support with handle <i>Halter mit Stosgriff</i>	830	722	827.171
Support with fixed wheels Ø 100 mm <i>Halter mit festen Rädern Ø 100 mm</i>	830	722	827.169
Support with rotating wheels Ø 100 mm <i>Halter mit drehbaren Rädern Ø 100 mm</i>	830	722	827.170

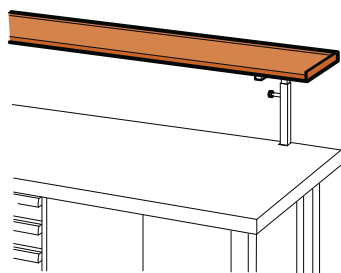

■ **Adjustable shelves**

■ **Verstellböden**

Multiplex shelf, 25 mm thick, planed and impregnated.

Multiplexplatte 25 mm stark, geschliffen und imprägniert.

Width Breite mm	Depth Tiefe mm	Brackets Konsolen Nr.	Code Bestell-Nr.
1500	300	2	827.372
1750	300	2	827.373
2000	300	2	827.374
2500	300	3	827.375
3000	300	3	827.376

Maximum distance between the brackets 1600 mm *Maximaler Konsolenabstand 1600 mm*

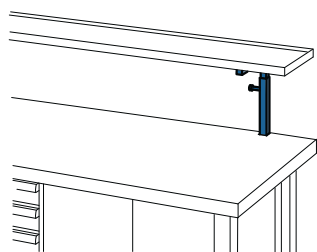

■ **Adjustable shelf brackets**

■ **Konsolen**

Tubular steel, powder coated, according to the colour chart. Adjustable Height. To be bolted to the workbench top. Fastening material included.

Aus Vierkantstahlrohr, pulverbeschichtet und einbrennlackiert nach Farbkarte. In der Höhe stufenlos verstellbar. Durch die Werkbankplatten verschraubt. Inklusive Befestigungsmaterial.

Depth Tiefe mm	Height over bench top Höhe über Platte mm	Code Bestell-Nr.
280	300-450	827.371

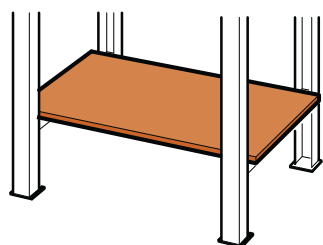

■ **Riser shelf, between bench legs**

■ **Ablegeboden, zwischen Werkbankfüße**

Multiplex shelf, 25 mm thick.

Multiplexplatte 25 mm Stärke.

For bench length Werkbanklänge mm	Shelf length Bodenlänge mm	Shelf depth Bodentiefe mm	Code Bestell-Nr.
1500	1200	620	827.509
1750	1450	620	827.510
2000	1700	620	827.511
2500	2200	620	827.512
3000	2700	620	827.513

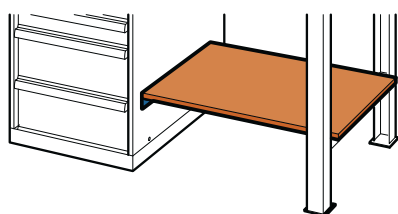

■ **Riser shelf, between drawer cabinet and bench**

■ **Ablegeboden, zwischen Schubladenschrank und Werkbankfuß**

Multiplex shelf, 25 mm thick. Steel sheet angle support, powder-coated according to the colour chart. Fastening material included.

Multiplexplatte 25 mm stark. Auflegewinkel aus Stahlblech, pulverbeschichtet und einbrennlackiert nach Farbkarte. Inklusive Befestigungsmaterial.

For bench length Werkbanklänge mm	Shelf length Bodenlänge mm	Shelf depth Bodentiefe mm	Code Bestell-Nr.
1500	765	620	827.514
1750	1015	620	827.515
2000	1265	620	827.516
2500	1765	620	827.517
3000	2265	620	827.518

Angle support
Auflegewinkel 827.481

■ Fixed foot rest

■ Feste Fußauflage

Steel sheet construction, powder coated according to the colour chart.

Aus Stahlblech, pulverbeschichtet und einbrennlackiert nach Farbkarte.



Bench length Bänkelänge mm	Foot rest length Fussauflägelänge mm	Supports for bench Halter pro Werkbank Nr.	Code Bestell-Nr.
1250	744	2	827.342
1500	994	2	827.337
1750	1244	2	827.343
2000	1494	2	827.334
2500	1994	2	827.332
2500	959	3	827.333
3000	1209	3	827.331

■ Foot rest

■ Fußauflage

Steel sheet construction, powder coated according to the colour chart. With rubber ribbed mat.

Aus Stahlblech, pulverbeschichtet und einbrennlackiert nach Farbkarte. Mit Gummi-Rillenmatte.

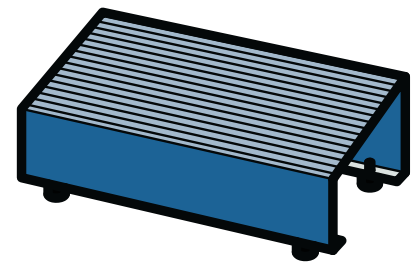

Height Höhe mm	Depth Tiefe mm	Width Breite mm	Code Bestell-Nr.
500	250	140	827.335



■ Straight hook
■ Gerader Werkzeughalterhaken

Lenght Länge mm	Diameter Durchmesser mm	Code * Bestell-Nr.
24	5	827.211
38	5	827.212
100	6	827.213

* 10 pieces set * Satz von 10 Stück



■ Double hook
■ Doppelter Haken

Lenght Länge mm	Diameter Durchmesser mm	Code * Bestell-Nr.
38	5	827.214
100	5	827.215

* 10 pieces set * Satz von 10 Stück



■ Single hook for tools
■ Einzelner Haken für Werkzeuge

Lenght Länge mm	Diameter Durchmesser mm	Code * Bestell-Nr.
50	6	827.216

* 10 pieces set * Satz von 10 Stück



■ Single spring hook
■ Einzelner Federhaken

Diameter Durchmesser mm	Code * Bestell-Nr.
12	827.217
18	827.218
25	827.219

* 10 pieces set * Satz von 10 Stück



■ Pair of pliers holder hooks
■ Paarhaken für Zange halten

Opening Öffnung mm	Code * Bestell-Nr.
20-43	827.220

* 10 pieces set * Satz von 10 Stück



■ Circular hook
■ Runder Haken

Diameter Durchmesser mm	Code * Bestell-Nr.
60	827.223
80	827.224

* 10 pieces set * Satz von 10 Stück

■ Ring hook
■ Ringförmiger Haken

Diameter Durchmesser mm	Code * Bestell-Nr.
40	827.225
60	827.226
80	827.227

* 10 pieces set * Satz von 10 Stück



■ Rack for screwdriver
■ Schraubendreherhalter

Lenght Länge mm	Code * Bestell-Nr.
238	827.221

* 5 pieces set * Satz von 5 Stück



■ Rack for keys
■ Schlüsselgestell

Lenght Länge mm	Code * Bestell-Nr.
555	827.222

* 5 pieces set * Satz von 5 Stück



■ Points holder
■ Spitzenhalter

Lenght Länge mm	Code * Bestell-Nr.
238	827.234

* 5 pieces set * Satz von 5 Stück



■ Shelf
■ Boden

Lenght Länge mm	Depth Tiefe mm	Code * Bestell-Nr.
350	120	827.228

* 5 pieces set * Satz von 5 Stück



■ Perforated panels and uprights
■ Lochplatten und Ständer

Lenght Länge mm	Height Höhe mm	Code * Bestell-Nr.
640	480	827.232
870	480	827.233
Upright Ständer	1000	827.231

* Fixing hooks included * Inklusive Befestigungshaken



EXAMPLES OF COMPOSITIONS
BESTELLBEISPIELE



Drawers height Schubladen- höhe mm	Height Höhe mm	Depth Tiefe mm	Lenght Länge mm	Code Bestell-Nr.
50	870	800	1500	827.600
100	870	800	2000	827.601
150				

- | | |
|-----------------------------|---------------------|
| 2 bench legs | 2 Werkbankfüße |
| 1 cabinet | 1 Schubladenschrank |
| 1 riser shelf | 1 Ablegeboden |
| 2 adjustable shelf brackets | 2 Konsolen |
| 1 adjustable shelf | 1 Boden |

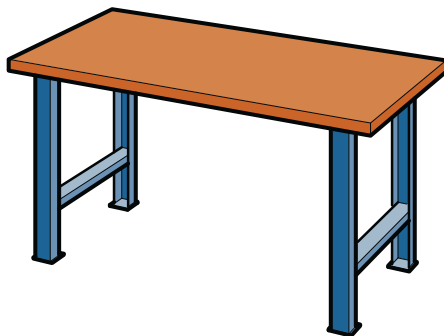

Height Höhe mm	Depth Tiefe mm	Lenght Länge mm	Code Bestell-Nr.
870	800	1500	827.602
870	800	1750	827.603
870	800	2000	827.604

- 2 bench legs 2 Werkbankfüße

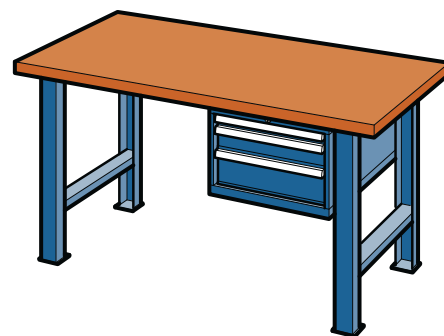

Drawers height Schubladen- höhe mm	Height Höhe mm	Depth Tiefe mm	Lenght Länge mm	Code Bestell-Nr.
50	870	800	1500	827.605
100	870	800	1750	827.606
150	870	800	2000	827.607

- 2 bench legs 2 Werkbankfüße
 1 cabinet 1 Schubladenschrank



Drawers height Schubladen- höhe mm	Height Höhe mm	Depth Tiefe mm	Lenght Länge mm	Code Bestell-Nr.
50	870	800	1500	827.608
100	870	800	2000	827.609
150				

- | | |
|---------------------|--------------------|
| 2 bench legs | 2 Werkbankfüße |
| 1 cabinet | 1 Schrank |
| 1 riser shelf | 1 Ablegeboden |
| 3 panel brackets | 3 Lochwandhalter |
| 4 perforated panels | 4 Gelochte Platten |

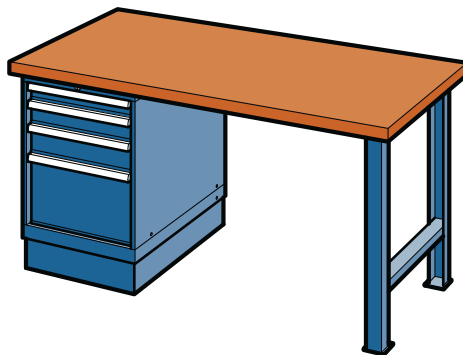

Drawers height Schubladen- höhe mm	Height Höhe mm	Depth Tiefe mm	Lenght Länge mm	Code Bestell-Nr.
75	870	800	1750	827.610
100				
125	870	800	2000	827.611
300				

- 1 bench leg 1 Werkbankfüße
 1 cabinet with base 1 Schrank mit Sockel
 H=130 mm H=130 mm

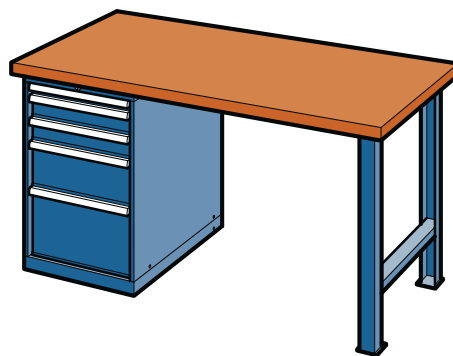

Drawers height Schubladen- höhe mm	Height Höhe mm	Depth Tiefe mm	Lenght Länge mm	Code Bestell-Nr.
50	890	800	1750	827.614
100				
200				
300	890	800	2000	827.615

- 1 bench leg 1 Werkbankfuß
 1 cabinet 1 Schubladenschrank

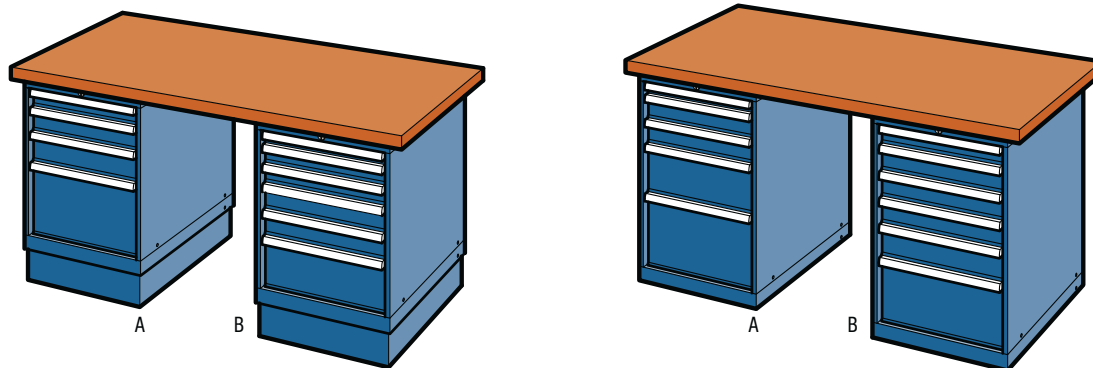

A	B	Height Höhe	Depth Tiefe	Lenght Länge	Code Bestell-Nr.
Drawers height Schubladenhöhe	Drawers height Schubladenhöhe				
75	50	870	800	1750	827.612
100	75				
125	75				
300	100	870	800	2000	827.613
	200				

2 Cabinet with bases
H=130 mm

2 Schränke mit Sockel
H=130 mm

A	B	Height Höhe	Depth Tiefe	Lenght Länge	Code Bestell-Nr.
Drawers height Schubladenhöhe	Drawers height Schubladenhöhe				
50	75	890	800	1750	827.616
100	100				
100	100				
200	100	890	800	2000	827.617
300	125				
	250				

2 cabinets

2 Schränke

■ Drawer for workbench type J12 ■ Schublade für Werkbank Typ J 12

Steel sheet construction, powder-coated according to the color chart. Useful to store all those tools habitually used on top of the workbench. Provided with one drawer of 150 and cylinder lock, it is fastened under the workbench wooden top by proper bolts.

Stahlblechkonstruktion, pulverbeschichtet und einbrennlackiert nach Farbkarte. Nützlich für die Unterbringung von allen Werkzeugen, die normalerweise über Werkbank benutzt werden. Versorgt mit einer Schublade von 150 und Sicherheitszylinderschloss. Es wird unter dem Abdeckplatt vom Werkbank mit geeigneten Riegeln gelegt.

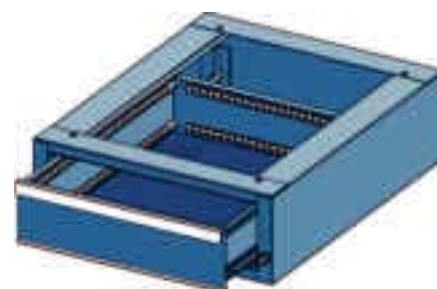

Height Höhe	Drawers height Schubladenhöhe	Usable height Nutzhöhe	Lenght Länge	Depth Tiefe	Code Bestell-Nr.
204	150	150	578	725	827.581

Drawer with 100% full extension
Schublade mit 100% Teleskopauszug