

INDICE PRODOTTI

PRODUCT
CONTENTS

pag. 78

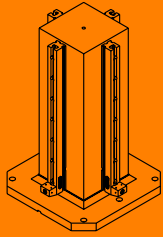

CUBO QUADRO
MULTIPRESA
MULTI-GRIP SQUARE
WORKCUBE

pag. 79

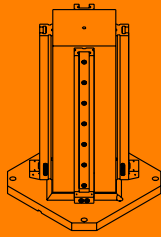

CUBO QUADRO 45°
MULTIPRESA
MULTI-GRIP 45°
SQUARE WORKCUBE

pag. 80

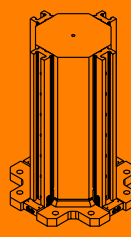

CUBO OTTAGONALE PLUS
MULTIPRESA
MULTI-GRIP PLUS
OCTAGONAL WORKCUBE

pag. 81

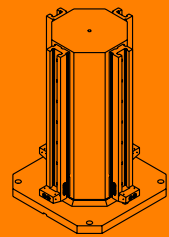

CUBO OTTAGONO
MULTIPRESA
MULTI-GRIP OCTAGONAL
WORKCUBE

pag. 82

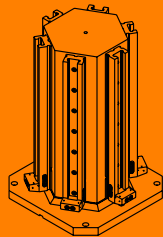

CUBO ESAGONALE
MULTIPRESA
MULTI-GRIP HEXAGONAL
WORKCUBE

pag. 83

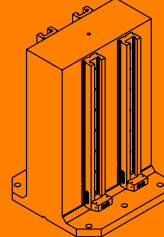

CUBO SPALLA
RASENTE MULTIPRESA
MULTI-GRIP CLOSE
SHOULDER WORKCUBE

pag. 84

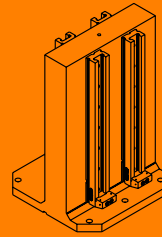

CUBO SPALLA DISASSATA
MULTIPRESA
MULTI-GRIP OFF CENTRE
SHOULDER CUBE

pag. 85

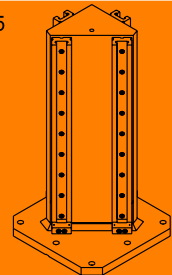

CUBO TRIANGOLO
MULTIPRESA
MULTI-GRIP TRIANGULAR
WORKCUBE

pag. 86-87

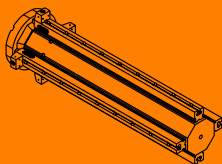

COLONNE MULTIPRESA
PER DIVISORI
MULTI-GRIP COLUMN
FOR DIVIDERS

CUBI MULTIPRESA
MULTI-GRIP WORK CUBES

MULTI-GRIP SQUARE WORKCUBE

CUBI MULTIPRESA
MULTI-GRIP WORK CUBES

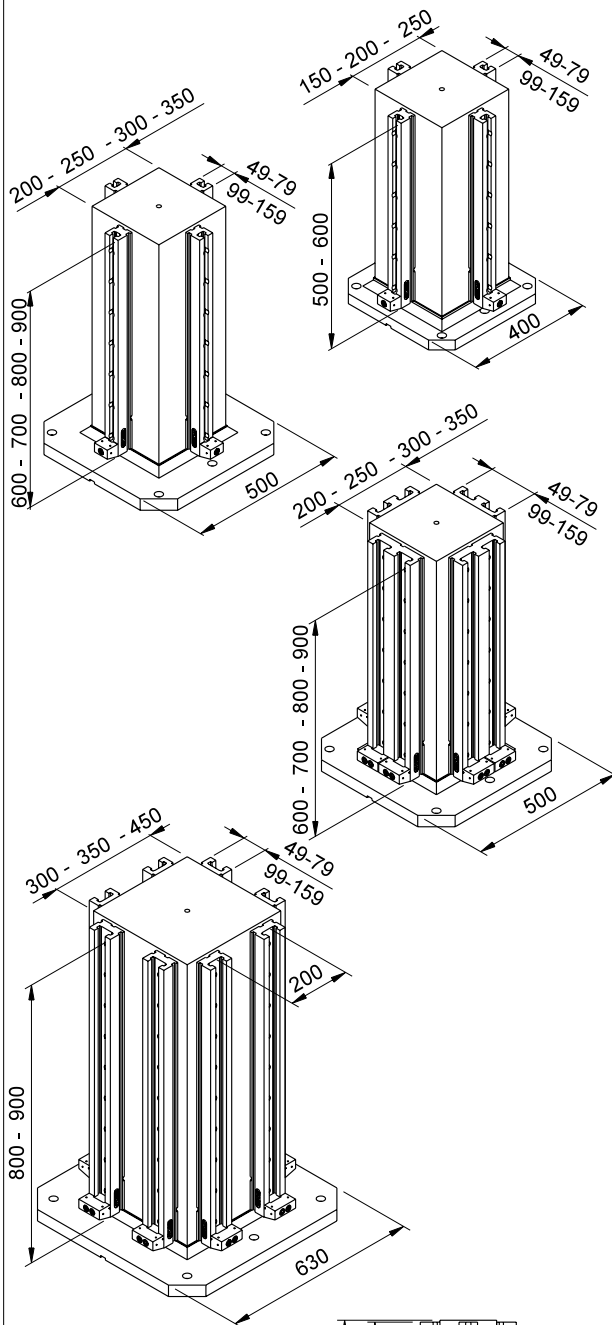

NB.: Il Cubo Multipresa è fornito con una presa pezzo per morsa. Per i gruppi di spinta aggiuntivi riferirsi alle schede delle morse.

N.B.: The multi-grip workcube is supplied with a vice piece grip. Refer to the vice specifications for the additional pushing unit.

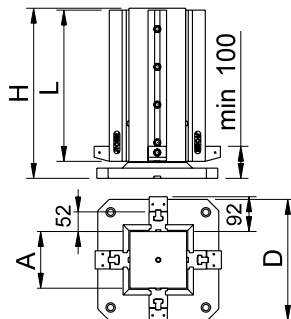

COD.	D	A	H	L	Size Vise	n° Vises	daN - Kg
J 02 320 S 50 _	320	100	450	400	50	4	70
J 02 320 S 80 _	320	100	450	400	80	4	88
J 02 321 S 50 _	320	150	450	400	50	4	80
J 02 321 S 80 _	320	150	450	400	80	4	98
J 02 400 S 50 _	400	150	570	500	50	4	126
J 02 400 S 80 _	400	150	570	500	80	4	146
J 02 401 S 50 _	400	250	570	500	50	4	176
J 02 401 S 80 _	400	250	570	500	80	4	196
J 02 402 S 50 _	400	200	670	600	50	4	172
J 02 402 S 80 _	400	200	670	600	80	4	194
J 02 402 S 100 _	400	200	670	600	100	4	218
J 02 402 S 160 _	400	200	670	600	160	4	262
J 02 403 S 50 _	400	250	670	600	50	4	192
J 02 403 S 80 _	400	250	670	600	80	4	214
J 02 403 S 100 _	400	250	670	600	100	4	238
J 02 403 S 160 _	400	250	670	600	160	4	282
J 02 500 S 50 _	500	200	670	600	50	4	202
J 02 500 S 80 _	500	200	670	600	80	4	224
J 02 500 S 100 _	500	200	670	600	100	4	248
J 02 500 S 160 _	500	200	670	600	160	4	290
J 02 501 S 50 _	500	250	670	600	50	4	222
J 02 501 S 80 _	500	250	670	600	80	4	244
J 02 501 S 100 _	500	250	670	600	100	4	268
J 02 501 S 160 _	500	250	670	600	160	4	312
J 02 502 S 50 _	500	250	770	700	50	4	248
J 02 502 S 80 _	500	250	770	700	80	4	272
J 02 502 S 100 _	500	250	770	700	100	4	300
J 02 502 S 160 _	500	250	770	700	160	4	348
J 02 503 S 50 _	500	350	770	700	50	4	308
J 02 503 S 80 _	500	350	770	700	80	4	332
J 02 503 S 100 _	500	350	770	700	100	4	360
J 02 503 S 160 _	500	350	770	700	160	4	408
J 02 504 S 50 _	500	250	870	800	50	4	272
J 02 504 S 80 _	500	250	870	800	80	4	300
J 02 504 S 100 _	500	250	870	800	100	4	332
J 02 504 S 160 _	500	250	870	800	160	4	388
J 02 505 S 50 _	500	250	970	900	50	4	290
J 02 505 S 80 _	500	250	970	900	80	4	322
J 02 505 S 100 _	500	250	970	900	100	4	354
J 02 505 S 160 _	500	250	970	900	160	4	414
J 02 630 S 80 _	630	300	870	800	80	8	450
J 02 630 S 160 _	630	300	870	800	160	4	458
J 02 631 S 80 _	630	350	870	800	80	8	490
J 02 631 S 160 _	630	350	870	800	160	4	498
J 02 632 S 80 _	630	350	970	900	80	8	534
J 02 632 S 160 _	630	350	970	900	160	4	540
J 02 633 S 80 _	630	450	970	900	80	12	706
J 02 633 S 160 _	630	450	970	900	160	8	798
Speciale							

Indicare la lettera del Tipo di presa pezzo (A,B,C,D,E,F,G)
Indicate the letter of the piece grip type (A,B,C,D,E,F,G)

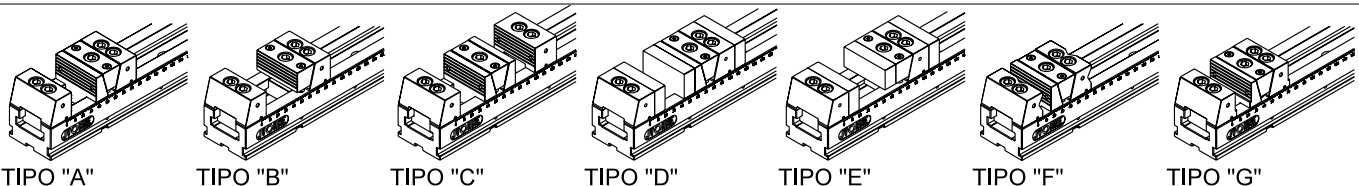

MULTI-GRIP 45° SQUARE WORKCUBE

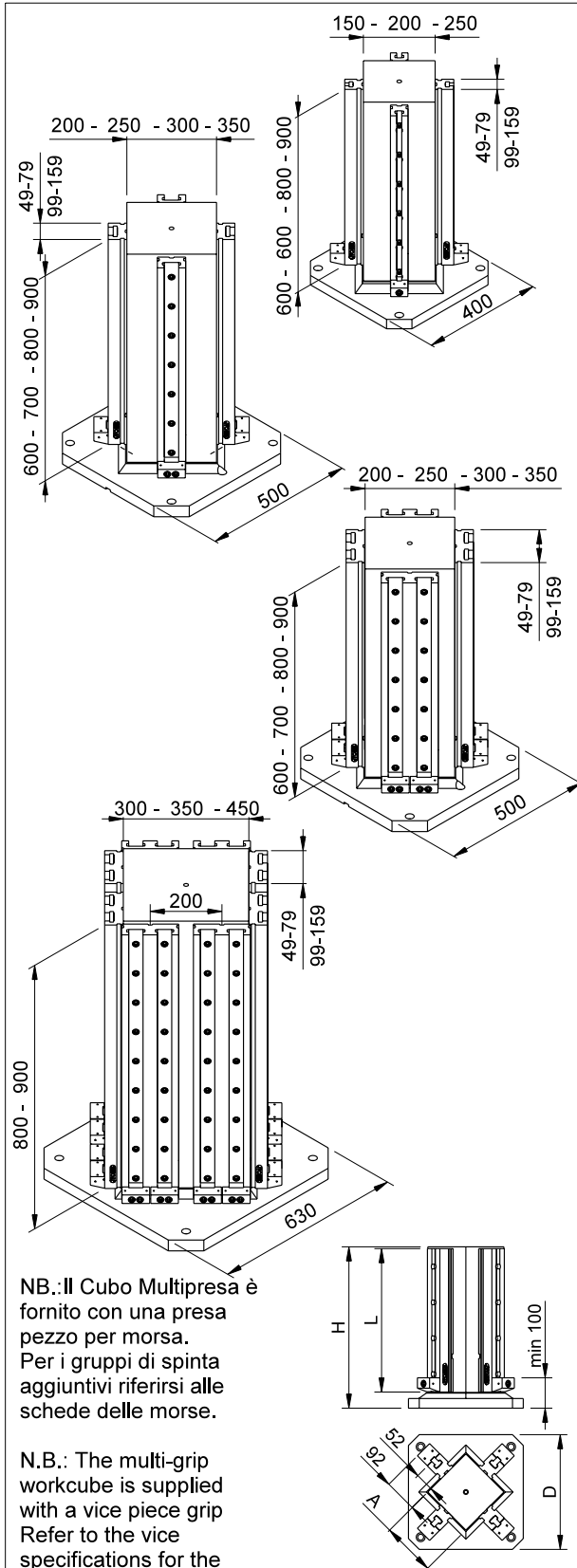

COD.	D	A	H	L	Size Vise	n° Vises	daN - Kg
J 38 320 S 50 _	320	100	450	400	50	4	70
J 38 320 S 80 _	320	100	450	400	80	4	88
J 38 321 S 50 _	320	150	450	400	50	4	80
J 38 321 S 80 _	320	150	450	400	80	4	98
J 38 400 S 50 _	400	150	570	500	50	4	126
J 38 400 S 80 _	400	150	570	500	80	4	146
J 38 401 S 50 _	400	250	570	500	50	4	176
J 38 401 S 80 _	400	250	570	500	80	4	196
J 38 402 S 50 _	400	200	670	600	50	4	172
J 38 402 S 80 _	400	200	670	600	80	4	194
J 38 402 S 100 _	400	200	670	600	100	4	218
J 38 402 S 160 _	400	200	670	600	160	4	262
J 38 403 S 50 _	400	250	670	600	50	4	192
J 38 403 S 80 _	400	250	670	600	80	4	214
J 38 403 S 100 _	400	250	670	600	100	4	238
J 38 403 S 160 _	400	250	670	600	160	4	282
J 38 500 S 50 _	500	200	670	600	50	4	202
J 38 500 S 80 _	500	200	670	600	80	4	224
J 38 500 S 100 _	500	200	670	600	100	4	248
J 38 500 S 160 _	500	200	670	600	160	4	290
J 38 501 S 50 _	500	250	670	600	50	4	222
J 38 501 S 80 _	500	250	670	600	80	4	244
J 38 501 S 100 _	500	250	670	600	100	4	268
J 38 501 S 160 _	500	250	670	600	160	4	312
J 38 502 S 50 _	500	250	770	700	50	4	248
J 38 502 S 80 _	500	250	770	700	80	4	272
J 38 502 S 100 _	500	250	770	700	100	4	300
J 38 502 S 160 _	500	250	770	700	160	4	348
J 38 503 S 50 _	500	350	770	700	50	4	308
J 38 503 S 80 _	500	350	770	700	80	4	332
J 38 503 S 100 _	500	350	770	700	100	4	360
J 38 503 S 160 _	500	350	770	700	160	4	408
J 38 504 S 50 _	500	250	870	800	50	4	272
J 38 504 S 80 _	500	250	870	800	80	4	300
J 38 504 S 100 _	500	250	870	800	100	4	332
J 38 504 S 160 _	500	250	870	800	160	4	388
J 38 505 S 50 _	500	250	970	900	50	4	290
J 38 505 S 80 _	500	250	970	900	80	4	322
J 38 505 S 100 _	500	250	970	900	100	4	354
J 38 505 S 160 _	500	250	970	900	160	4	414
J 38 630 S 80 _	630	300	870	800	80	8	450
J 38 630 S 160 _	630	300	870	800	160	4	458
J 38 631 S 80 _	630	350	870	800	80	8	490
J 38 631 S 160 _	630	350	870	800	160	4	498
J 38 632 S 80 _	630	350	970	900	80	8	534
J 38 632 S 160 _	630	350	970	900	160	4	540
J 38 633 S 80 _	630	450	970	900	80	12	706
J 38 633 S 160 _	630	450	970	900	160	8	798
Speciale							

Indicare la lettera del Tipo di presa pezzo (A,B,C,D,E,F,G)
Indicate the letter of the piece grip type (A,B,C,D,E,F,G)

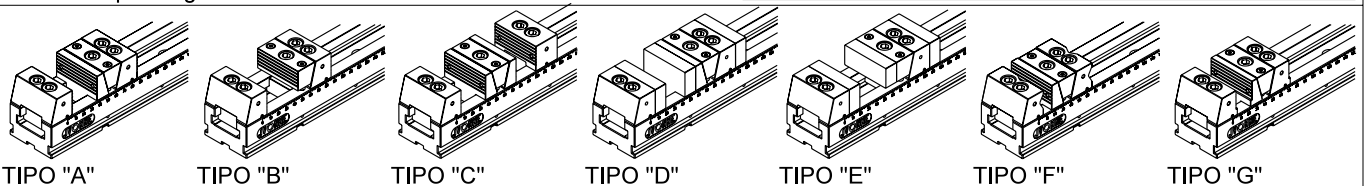
 CUBI MULTIPRESA
MULTI-GRIP WORK CUBES

MULTI-GRIP PLUS OCTAGONAL WORKCUBE

CUBI MULTIPRESA
MULTI-GRIP WORK CUBES

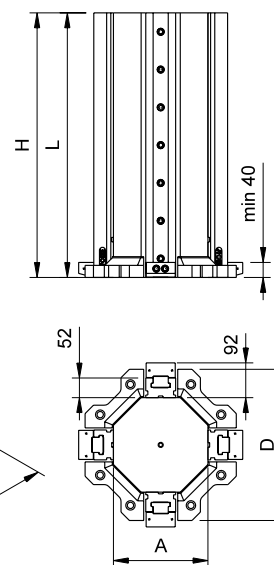
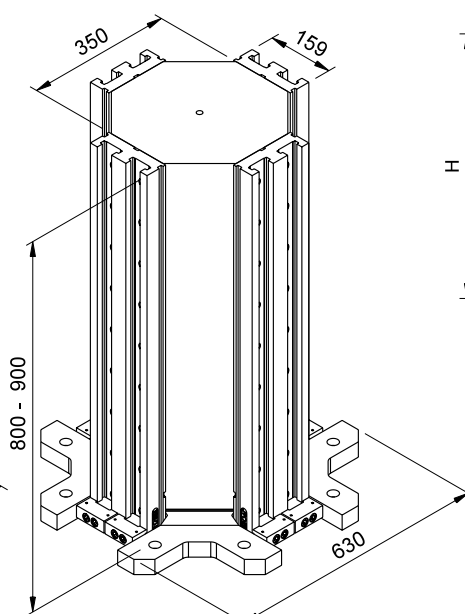
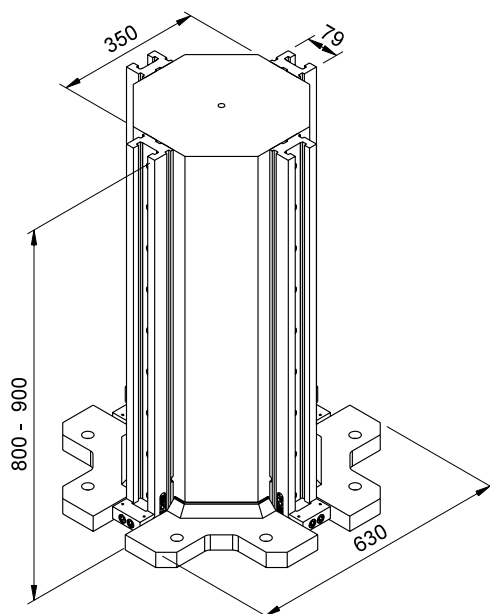
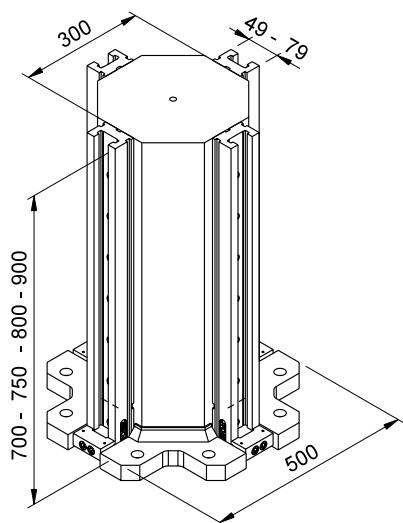
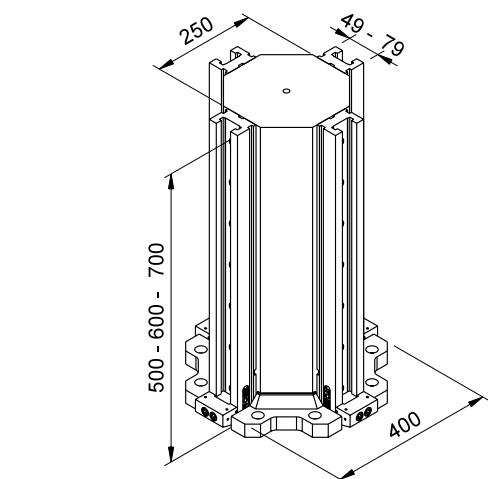

COD.	D	A	H	L	Size Vise	n° Vises	daN - Kg
J 55 402 S 50 _	400	250	500	500	50	4	140
J 55 402 S 80 _	400	250	500	500	80	4	155
J 55 403 S 50 _	400	250	600	600	50	4	155
J 55 403 S 80 _	400	250	600	600	80	4	175
J 55 404 S 50 _	400	250	700	700	50	4	170
J 55 404 S 80 _	400	250	700	700	80	4	190
J 55 502 S 50 _	500	300	700	700	50	4	230
J 55 502 S 80 _	500	300	700	700	80	4	250
J 55 502 S 100 _	500	300	700	700	100	4	280
J 55 503 S 50 _	500	300	750	750	50	4	220
J 55 503 S 80 _	500	300	750	750	80	4	250
J 55 503 S 100 _	500	300	750	750	100	4	275
J 55 504 S 50 _	500	300	800	800	50	4	230
J 55 504 S 80 _	500	300	800	800	80	4	255
J 55 504 S 100 _	500	300	800	800	100	4	290
J 55 505 S 50 _	500	300	900	900	50	4	250
J 55 505 S 80 _	500	300	900	900	80	4	280
J 55 505 S 100 _	500	300	900	900	100	4	305
J 55 631 S 80 _	630	350	800	800	80	4	300
J 55 631 S 160 _	630	350	800	800	160	4	390
J 55 632 S 50 _	630	350	900	900	50	4	325
J 55 632 S 80 _	630	350	900	900	80	4	335
J 55 632 S 160 _	630	350	900	900	160	4	415
Speciale							

Indicare la lettera del Tipo di presa pezzo (A,B,C,D,E,F,G)
Indicate the letter of the piece grip type (A,B,C,D,E,F,G)

NB.: Il Cubo Multipresa è fornito con una presa pezzo per morsa.
Per i gruppi di spinta aggiuntivi riferirsi alle schede delle morse.

N.B.: The multi-grip workcube is supplied with a vice piece grip
Refer to the vice specifications for the additional pushing unit

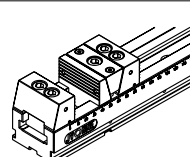

TIPO "A"

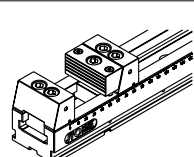

TIPO "B"

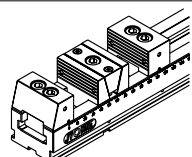

TIPO "C"

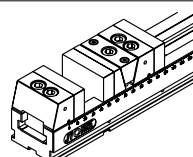

TIPO "D"

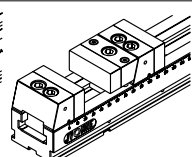

TIPO "E"

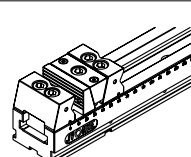

TIPO "F"

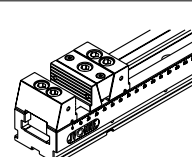

TIPO "G"

MULTI-GRIP OCTAGONAL WORKCUBE

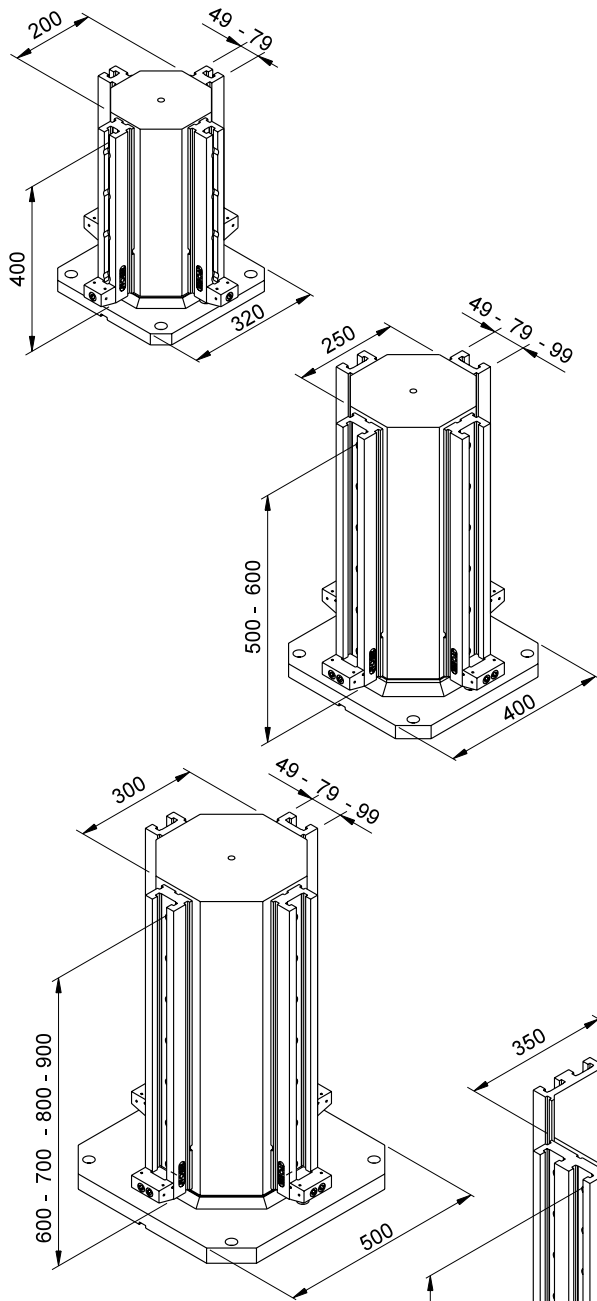

COD.	D	A	H	L	Size Vise	n° Vises	daN - Kg
J 18 320 S 50 _	320	200	450	400	50	4	100
J 18 320 S 80 _	320	200	450	400	80	4	120
J 18 400 S 50 _	400	250	670	600	50	4	175
J 18 400 S 80 _	400	250	670	600	80	4	195
J 18 400 S 100 _	400	250	670	600	100	4	220
J 18 401 S 50 _	400	250	570	500	50	4	155
J 18 401 S 80 _	400	250	570	500	80	4	175
J 18 401 S 100 _	400	250	570	500	100	4	195
J 18 500 S 50 _	500	300	770	700	50	4	240
J 18 500 S 80 _	500	300	770	700	80	4	265
J 18 500 S 100 _	500	300	770	700	100	4	290
J 18 501 S 50 _	500	300	670	600	50	4	225
J 18 501 S 80 _	500	300	670	600	80	4	245
J 18 501 S 100 _	500	300	670	600	100	4	270
J 18 502 S 50 _	500	300	870	800	50	4	255
J 18 502 S 80 _	500	300	870	800	80	4	280
J 18 502 S 100 _	500	300	870	800	100	4	315
J 18 503 S 50 _	500	300	970	900	50	4	270
J 18 503 S 80 _	500	300	970	900	80	4	305
J 18 503 S 100 _	500	300	970	900	100	4	335
J 18 630 S 50 _	630	350	970	900	50	4	345
J 18 630 S 80 _	630	350	970	900	80	4	385
J 18 630 S 160 _	630	350	970	900	160	4	475
J 18 631 S 80 _	630	350	870	800	80	4	355
J 18 631 S 160 _	630	350	870	800	160	4	445
Speciale							

Indicare la lettera del Tipo di presa pezzo (A,B,C,D,E,F,G)
Indicate the letter of the piece grip type (A,B,C,D,E,F,G)

NB.: Il Cubo Multipresa è fornito con una presa pezzo per morsa.
Per i gruppi di spinta aggiuntivi riferirsi alle schede delle morse.

N.B.: The multi-grip workcube is supplied with a vice piece grip
Refer to the vice specifications for the additional pushing unit

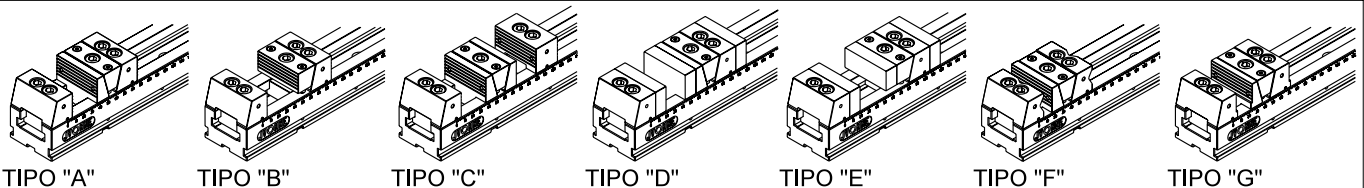
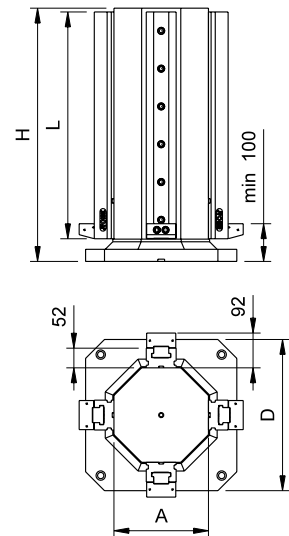

MULTI-GRIP HEXAGONAL WORKCUBE

CUBI MULTIPRESA
MULTI-GRIP WORK CUBES

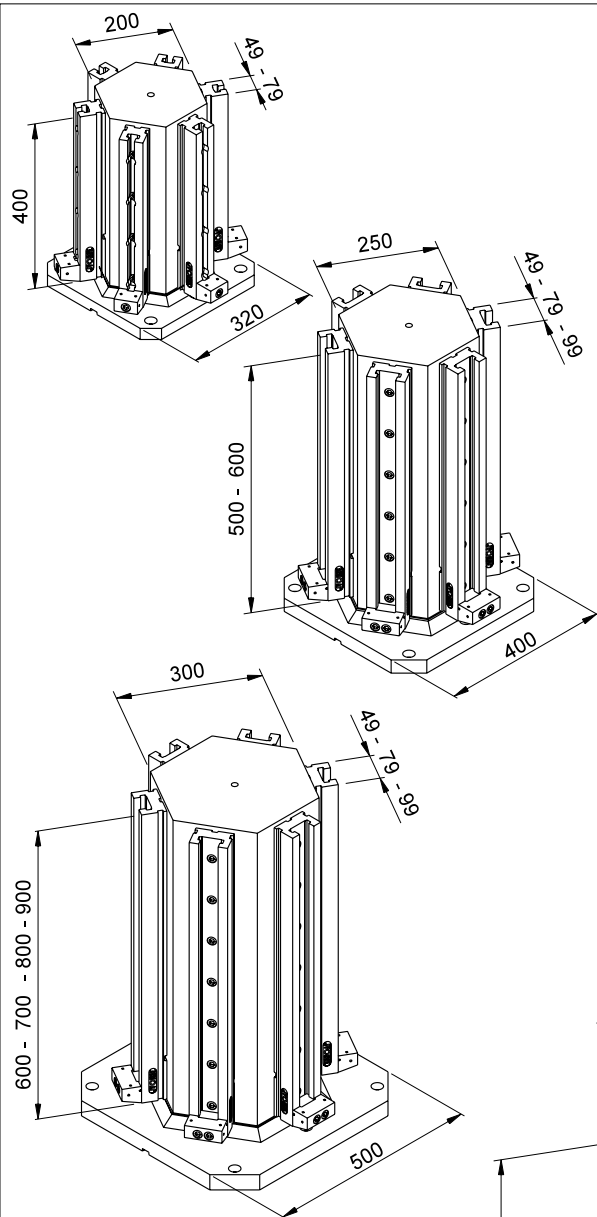

COD.	D	A	H	L	Size Vise	n° Vises	daN - Kg
J 16 320 S 50_	320	200	450	400	50	6	105
J 16 320 S 80_	320	200	450	400	80	6	135
J 16 400 S 50_	400	250	670	600	50	6	195
J 16 400 S 80_	400	250	670	600	80	6	225
J 16 400 S 100_	400	250	670	600	100	6	265
J 16 401 S 50_	400	250	570	500	50	6	175
J 16 401 S 80_	400	250	570	500	80	6	205
J 16 401 S 100_	400	250	570	500	100	6	235
J 16 500 S 50_	500	300	770	700	50	6	265
J 16 500 S 80_	500	300	770	700	80	6	300
J 16 500 S 100_	500	300	770	700	100	6	340
J 16 501 S 50_	500	300	670	600	50	6	245
J 16 501 S 80_	500	300	670	600	80	6	275
J 16 501 S 100_	500	300	670	600	100	6	315
J 16 502 S 50_	500	300	870	800	50	6	280
J 16 502 S 80_	500	300	870	800	80	6	320
J 16 502 S 100_	500	300	870	800	100	6	370
J 16 503 S 50_	500	300	970	900	50	6	300
J 16 503 S 80_	500	300	970	900	80	6	350
J 16 503 S 100_	500	300	970	900	100	6	375
J 16 630 S 50_	630	350	970	900	50	6	390
J 16 630 S 80_	630	350	970	900	80	6	430
J 16 630 S 160_	630	350	970	900	160	6	565
J 16 631 S 80_	630	350	870	800	80	6	400
J 16 631 S 160_	630	350	870	800	160	6	530
Speciale							

Indicare la lettera del Tipo di presa pezzo (A,B,C,D,E,F,G)
Indicate the letter of the piece grip type (A,B,C,D,E,F,G)

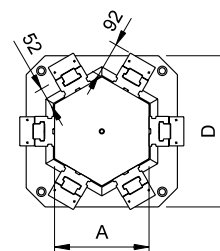
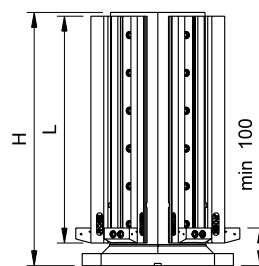
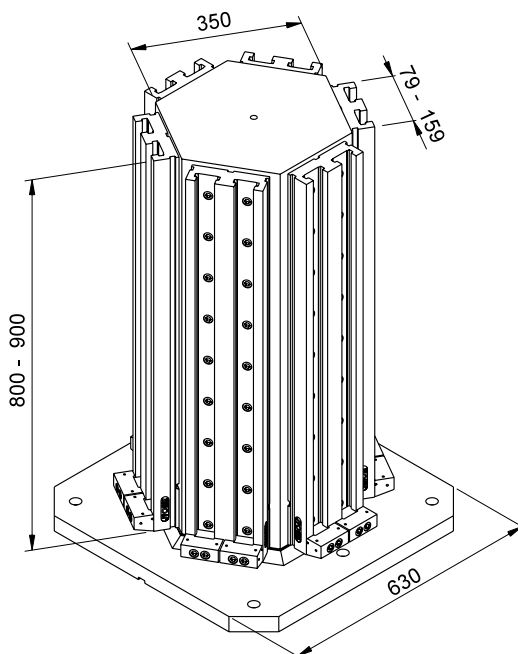

NB.: Il Cubo Multipresa è fornito con una presa pezzo per morsa.
Per i gruppi di spinta aggiuntivi riferirsi alle schede delle morse.

N.B.: The multi-grip workcube is supplied with a vice piece grip
Refer to the vice specifications for the additional pushing unit

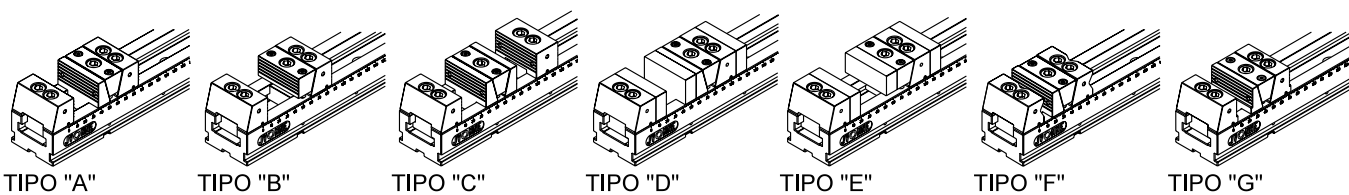

MULTI-GRIP CLOSE SHOULDER WORKCUBE

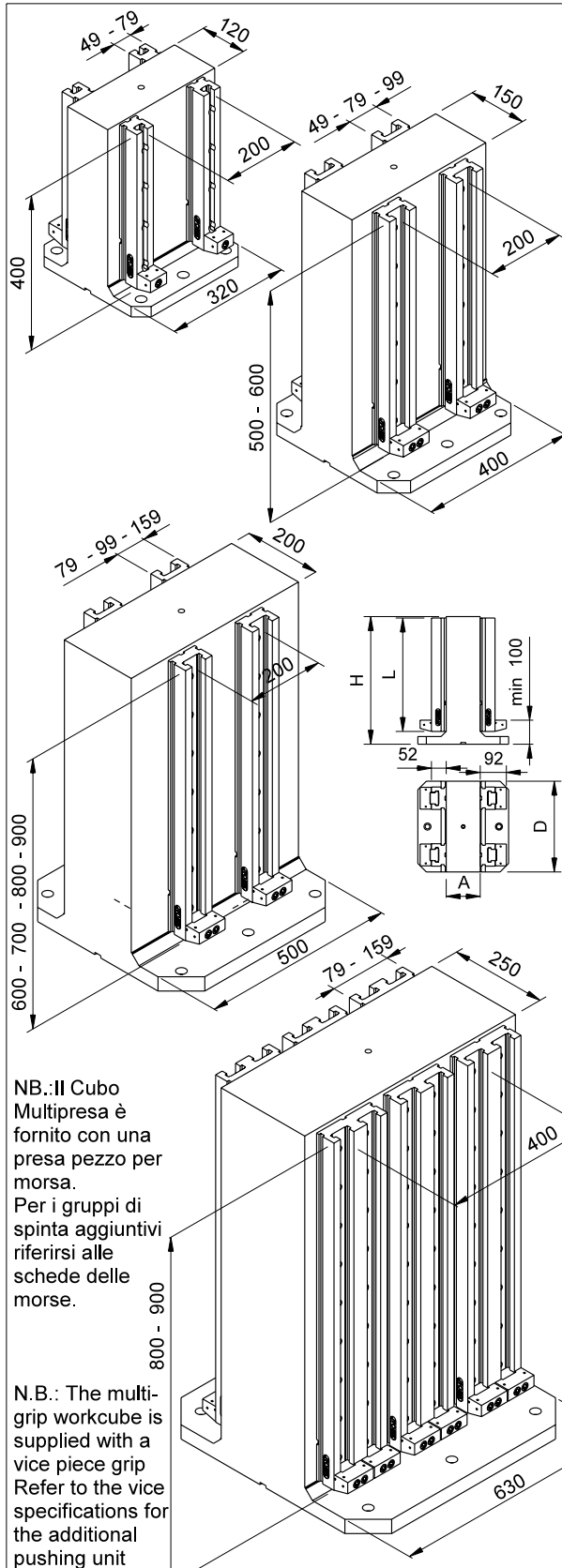

COD.	D	A	H	L	Size Vise	n° Vises	daN - Kg
J 36 320 S 50 _	320	80	450	400	50	4	100
J 36 320 S 80 _	320	80	450	400	80	4	120
J 36 321 S 80 _	320	120	450	400	50	4	100
J 36 321 S 80 _	320	120	450	400	80	4	120
J 36 400 S 50 _	400	100	570	500	50	4	165
J 36 400 S 80 _	400	100	570	500	80	4	185
J 36 401 S 50 _	400	150	570	500	50	4	175
J 36 401 S 80 _	400	150	570	500	80	4	195
J 36 402 S 50 _	400	100	670	600	50	4	195
J 36 402 S 80 _	400	100	670	600	80	4	215
J 36 402 S 100 _	400	100	670	600	100	4	240
J 36 402 S 160 _	400	100	670	600	160	4	285
J 36 403 S 50 _	400	150	670	600	50	4	205
J 36 403 S 80 _	400	150	670	600	80	4	225
J 36 403 S 100 _	400	150	670	600	100	4	250
J 36 403 S 160 _	400	150	670	600	160	4	295
J 36 500 S 50 _	500	120	670	600	50	4	255
J 36 500 S 80 _	500	120	670	600	80	4	275
J 36 500 S 100 _	500	120	670	600	100	4	300
J 36 500 S 160 _	500	120	670	600	160	4	345
J 36 501 S 50 _	500	200	670	600	50	4	275
J 36 501 S 80 _	500	200	670	600	80	4	295
J 36 501 S 100 _	500	200	670	600	100	4	320
J 36 501 S 160 _	500	200	670	600	160	4	365
J 36 502 S 50 _	500	120	770	700	50	4	280
J 36 502 S 80 _	500	120	770	700	80	4	300
J 36 502 S 100 _	500	120	770	700	100	4	330
J 36 502 S 160 _	500	120	770	700	160	4	380
J 36 503 S 50 _	500	200	770	700	50	4	310
J 36 503 S 80 _	500	200	770	700	80	4	335
J 36 503 S 100 _	500	200	770	700	100	4	360
J 36 503 S 160 _	500	200	770	700	160	4	410
J 36 504 S 50 _	500	200	870	800	50	4	330
J 36 504 S 80 _	500	200	870	800	80	4	350
J 36 505 S 50 _	500	200	970	900	50	4	350
J 36 505 S 80 _	500	200	970	900	80	4	370
J 36 630 S 80 _	630	200	870	800	80	4	440
J 36 630 S 160 _	630	200	870	800	160	4	530
J 36 631 S 80 _	630	250	870	800	80	4	460
J 36 631 S 160 _	630	250	870	800	160	4	550
J 36 632 S 80 _	630	200	970	900	80	6	530
J 36 632 S 164 _	630	200	970	900	160	4	580
J 36 632 S 160 _	630	200	970	900	160	6	665
J 36 633 S 80 _	630	250	970	900	80	6	550
J 36 633 S 164 _	630	250	970	900	160	4	595
J 36 633 S 160 _	630	250	970	900	160	6	685
Speciale							

Indicare la lettera del Tipo di presa pezzo (A,B,C,D,E,F,G)
Indicate the letter of the piece grip type (A,B,C,D,E,F,G)

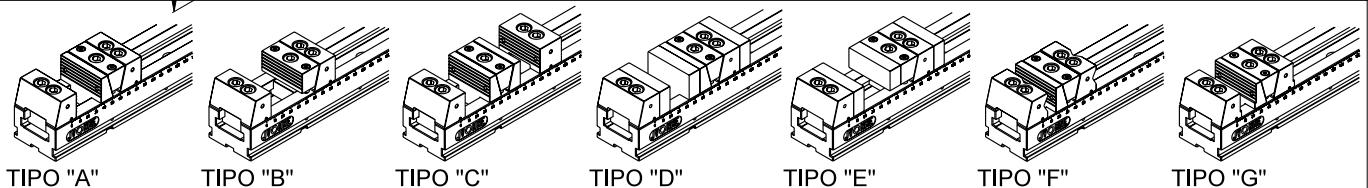

CUBI MULTIPRESA
MULTI-GRIP WORK CUBES

MULTI-GRIP OFF CENTRE SHOULDER CUBE

**CUBI MULTIPRESA
MULTI-GRIP WORK CUBES**

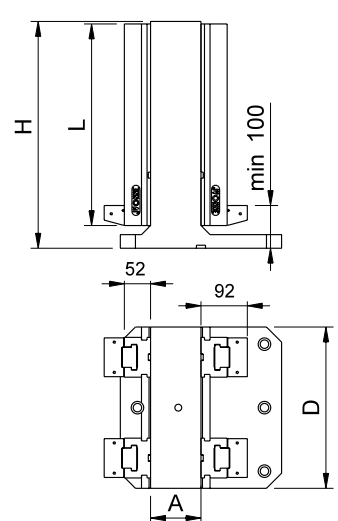
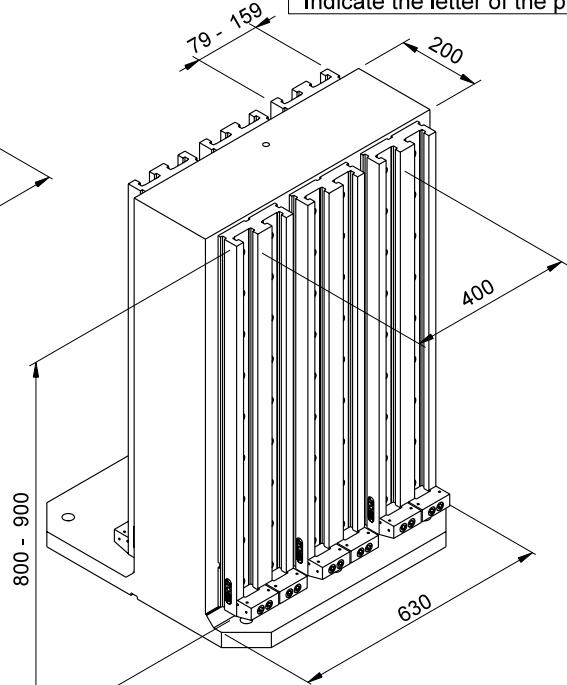
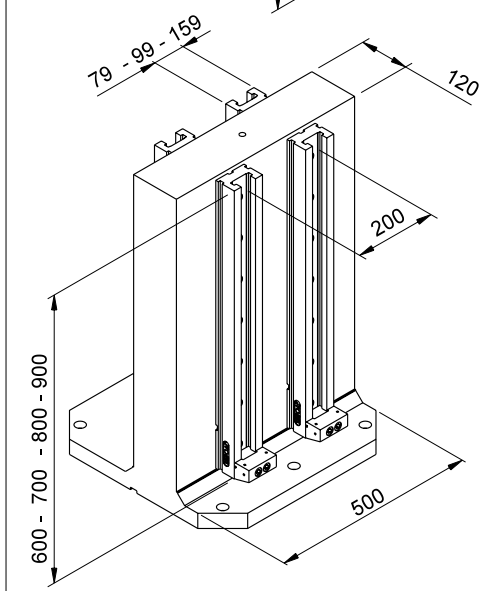
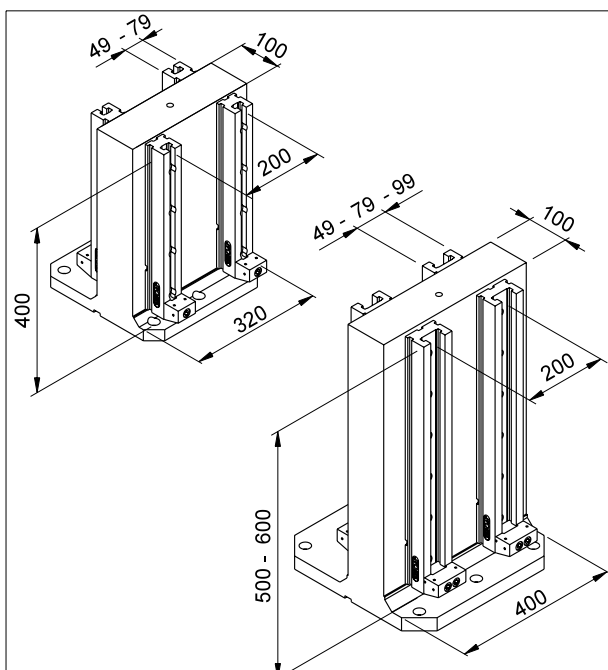

COD.	D	A	H	L	Size Vise	n° Vises	daN - Kg
J 12 320 S 50_	320	80	450	400	50	4	120
J 12 320 S 80_	320	80	450	400	80	4	140
J 12 400 S 50_	400	100	570	500	50	4	205
J 12 400 S 80_	400	100	570	500	80	4	225
J 12 401 S 50_	400	100	670	600	50	4	235
J 12 401 S 80_	400	100	670	600	80	4	255
J 12 401 S 100_	400	100	670	600	100	4	280
J 12 401 S 160_	400	100	670	600	160	4	325
J 12 500 S 50_	500	120	670	600	50	4	305
J 12 500 S 80_	500	120	670	600	80	4	325
J 12 500 S 100_	500	120	670	600	100	4	350
J 12 500 S 160_	500	120	670	600	160	4	395
J 12 501 S 50_	500	120	770	700	50	4	340
J 12 501 S 80_	500	120	770	700	80	4	365
J 12 501 S 100_	500	120	770	700	100	4	390
J 12 501 S 160_	500	120	770	700	160	4	440
J 12 504 S 50_	500	120	870	800	50	4	375
J 12 504 S 80_	500	120	870	800	80	4	405
J 12 505 S 50_	500	120	970	900	50	4	410
J 12 505 S 80_	500	120	970	900	80	4	445
J 12 630 S 80_	630	200	870	800	80	4	600
J 12 630 S 160_	630	200	870	800	160	4	690
J 12 631 S 80_	630	200	970	900	80	6	700
J 12 631 S 160_	630	200	970	900	160	6	840
J 12 631 S 164_	630	200	970	900	160	4	750
Speciale							

Indicare la lettera del Tipo di presa pezzo (A,B,C,D,E,F,G)
Indicate the letter of the piece grip type (A,B,C,D,E,F,G)

NB.: Il Cubo Multipresa è fornito con una presa pezzo per morsa. Per i gruppi di spinta aggiuntivi riferirsi alle schede delle morse.

N.B.: The multi-grip workcube is supplied with a vice piece grip. Refer to the vice specifications for the additional pushing unit.

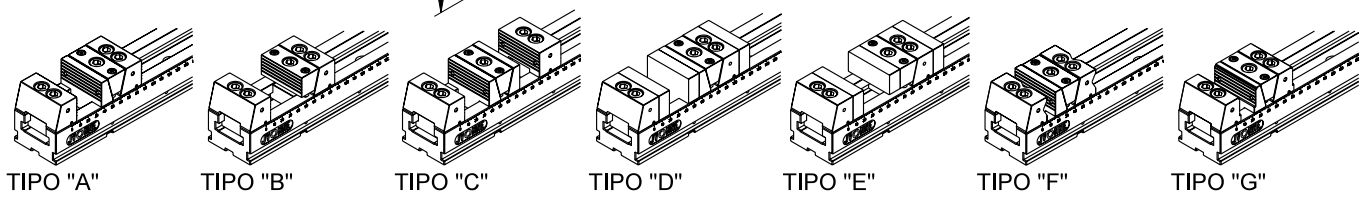

MULTI-GRIP TRIANGULAR WORKCUBE

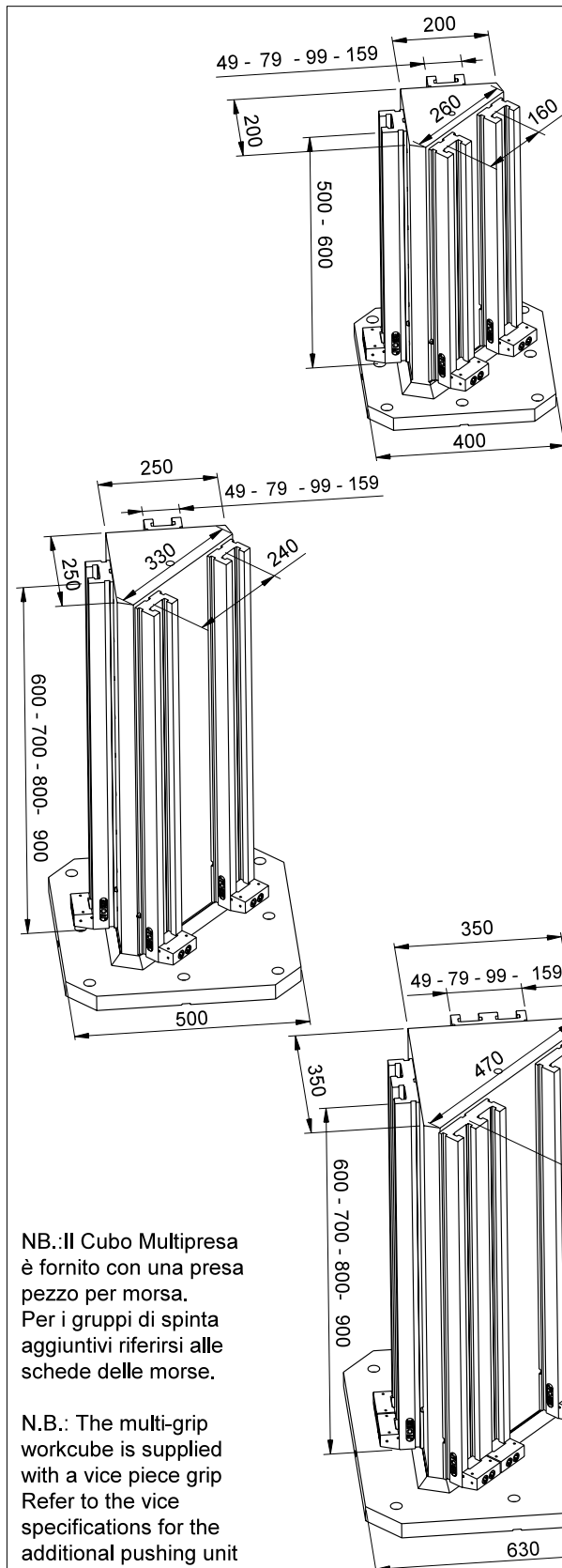

COD.	D	A	H	L	Size Vise	n° Vises	daN - Kg
J 39 400 S 50 _	400	200	670	600	50	4	160
J 39 400 S 80 _	400	200	670	600	80	4	180
J 39 400 S 100 _	400	200	670	600	100	4	205
J 39 400 S 160 _	400	200	670	600	160	4	245
J 39 401 S 50 _	400	200	570	500	50	4	140
J 39 401 S 80 _	400	200	570	500	80	4	160
J 39 401 S 100 _	400	200	570	500	100	4	185
J 39 401 S 160 _	400	200	570	500	160	4	225
J 39 500 S 50 _	500	250	670	600	50	4	210
J 39 500 S 80 _	500	250	670	600	80	4	230
J 39 500 S 100 _	500	250	670	600	100	4	250
J 39 500 S 160 _	500	250	670	600	160	4	305
J 39 501 S 50 _	500	250	770	700	50	4	230
J 39 501 S 80 _	500	250	770	700	80	4	255
J 39 501 S 100 _	500	250	770	700	100	4	275
J 39 501 S 160 _	500	250	770	700	160	4	335
J 39 502 S 50 _	500	250	870	800	50	4	250
J 39 502 S 80 _	500	250	870	800	80	4	280
J 39 502 S 100 _	500	250	870	800	100	4	305
J 39 502 S 160 _	500	250	870	800	160	4	365
J 39 503 S 50 _	500	250	970	900	50	4	270
J 39 503 S 80 _	500	250	970	900	80	4	305
J 39 503 S 100 _	500	250	970	900	100	4	335
J 39 503 S 160 _	500	250	970	900	160	4	395
J 39 630 S 50 _	630	350	970	900	50	4	375
J 39 630 S 80 _	630	350	970	900	80	4	405
J 39 630 S 160 _	630	350	970	900	160	4	500
J 39 631 S 50 _	630	350	870	800	50	4	350
J 39 631 S 80 _	630	350	870	800	80	4	375
J 39 631 S 160 _	630	350	870	800	160	4	460
Speciale							

Indicare la lettera del Tipo di presa pezzo (A,B,C,D,E,F,G)
Indicate the letter of the piece grip type (A,B,C,D,E,F,G)

NB.:Il Cubo Multipresa è fornito con una presa pezzo per morsa. Per i gruppi di spinta aggiuntivi riferirsi alle schede delle morse.

N.B.: The multi-grip workcube is supplied with a vice piece grip. Refer to the vice specifications for the additional pushing unit.

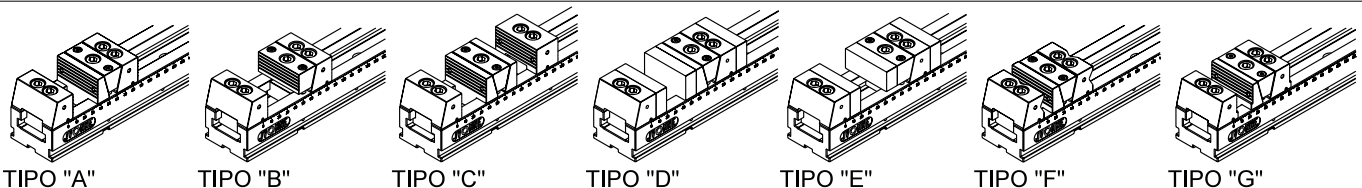
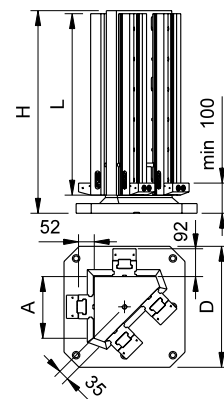

CUBI MULTIPRESA
MULTI-GRIP WORK CUBES

MULTI-GRIP COLUMN FOR DIVIDERS

CUBI MULTIPRESA
MULTI-GRIP WORK CUBES

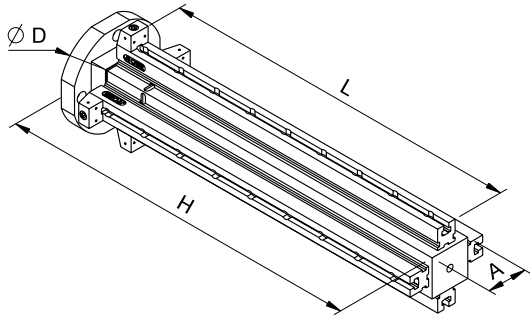

COLONNA QUADRA PER DIVISORE

COD.	D	A	H	L	min. H	Size Vise	n° Vises
J 41							
Speciale							

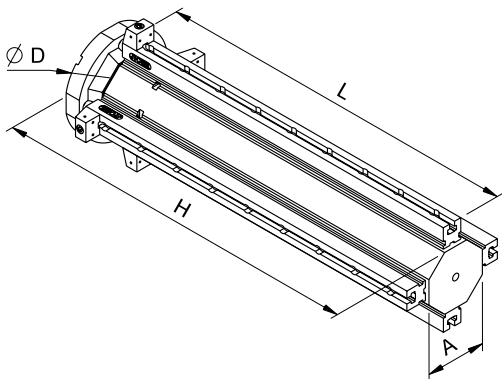
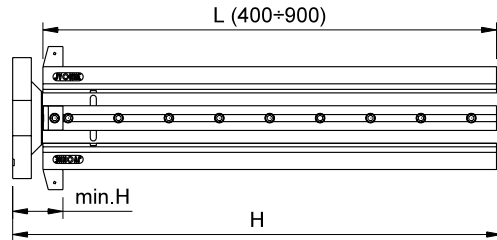
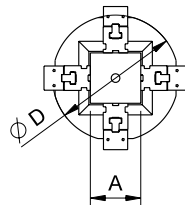

COLONNA OTTAGONALE PER DIVISORE

COD.	D	A	H	L	min. H	Size Vise	n° Vises
J 42							
Speciale							

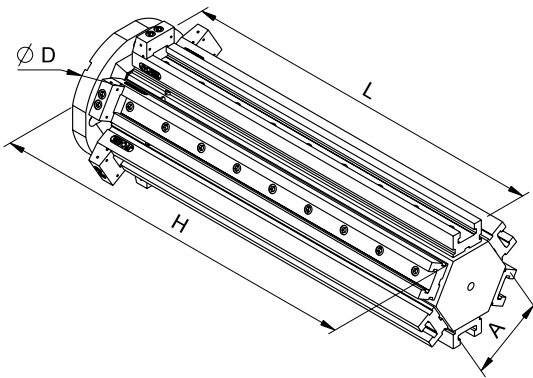
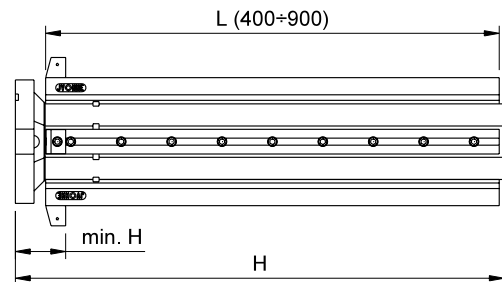
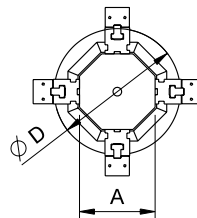

COLONNA ESAGONALE PER DIVISORE

COD.	D	A	H	L	min. H	Size Vise	n° Vises
J 43							
Speciale							

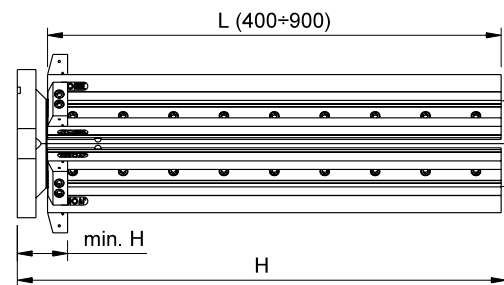
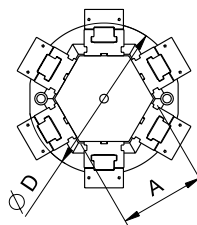

NB.: Il Cubo Multipresa è fornito con una presa pezzo per morsa.
Per i gruppi di spinta aggiuntivi riferirsi alle schede delle morse.

N.B.: The multi-grip column is supplied with a vice piece grip
Refer to the vice specifications for the additional pushing unit

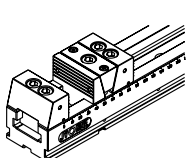

TIPO "A"

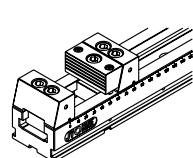

TIPO "B"

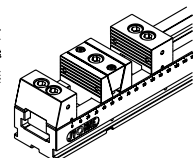

TIPO "C"

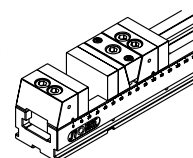

TIPO "D"

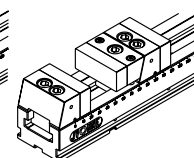

TIPO "E"

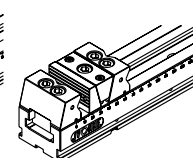

TIPO "F"

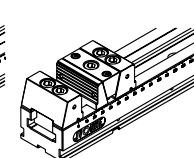

TIPO "G"

MULTI-GRIP COLUMN FOR DIVIDERS

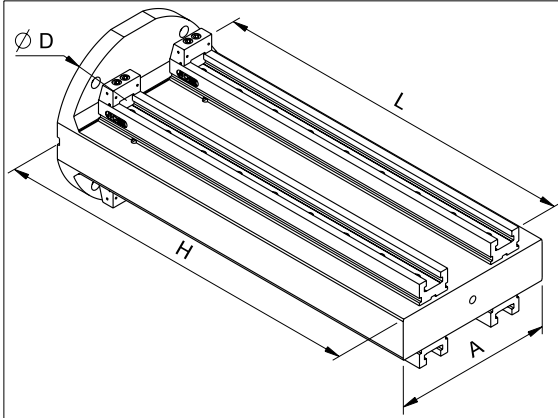

COLONNA SPALLA PER DIVISORE

COD.	D	A	H	L	min. H	Size Vise	n° Vises
J 44							
Speciale							

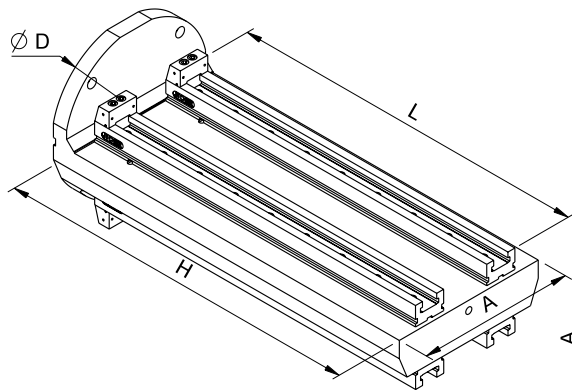
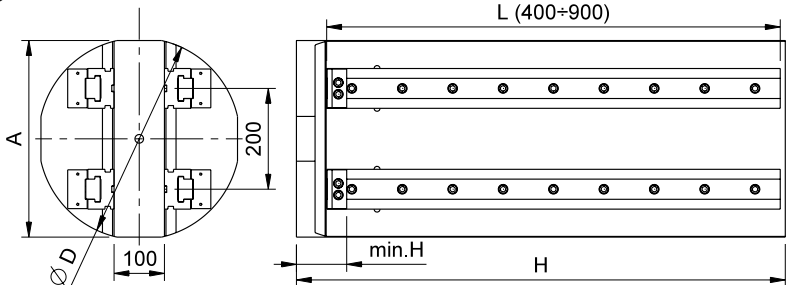

COLONNA SPALLA DISASSATA PER DIVISORE

COD.	D	A	H	L	min. H	Size Vise	n° Vises
J 45							
Speciale							

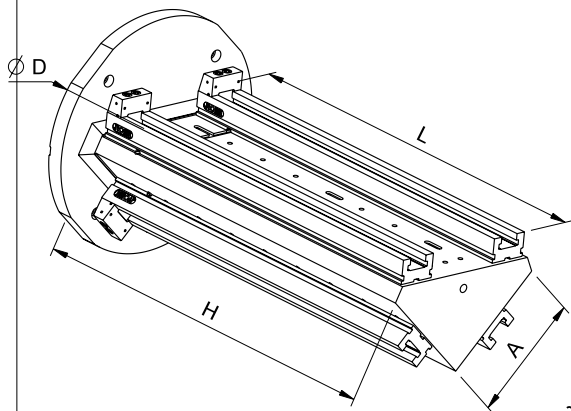
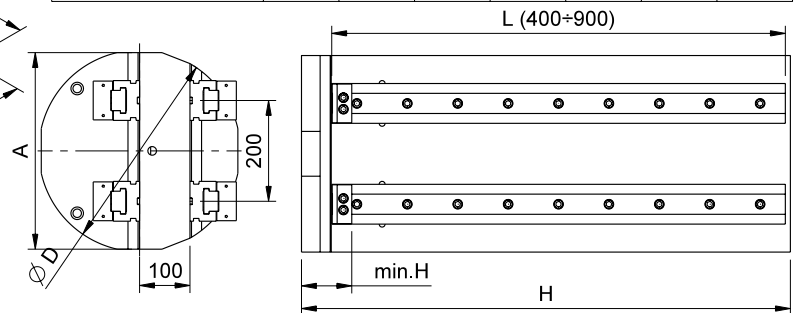

COLONNA TRIANGOLO PER DIVISORE

COD.	D	A	H	L	min. H	Size Vise	n° Vises
J 46							
Speciale							

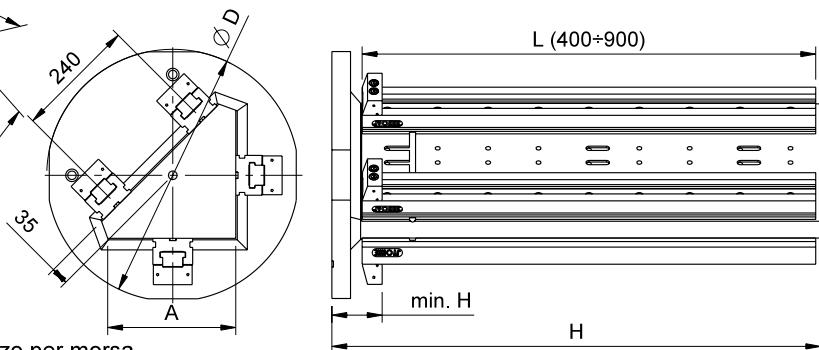

NB.: Il Cubo Multipresa è fornito con una presa pezzo per morsa.
Per i gruppi di spinta aggiuntivi riferirsi alle schede delle morse.

N.B.: The multi-grip column is supplied with a vice piece grip
Refer to the vice specifications for the additional pushing unit

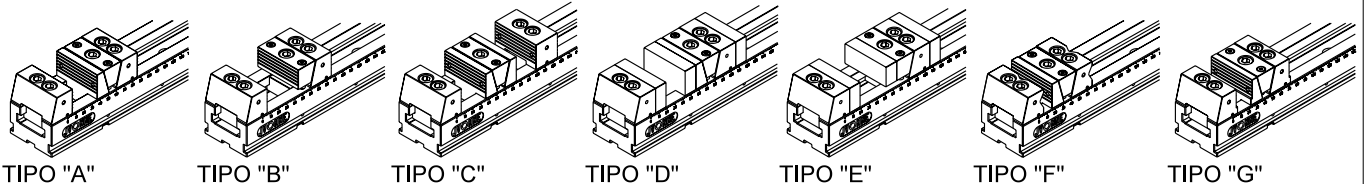

CUBI MULTIPRESA
MULTI-GRIP WORK CUBES