

# KINTEK®

## HYDRO-EXPANSION CHUCKS FOR TOOLS WITH CYLINDRICAL SHANK

MANDRINI IDRAULICI PER UTENSILI ATTACCO CILINDRICO



[www.kintek.it](http://www.kintek.it)

# HYDRO-EXPANSION CHUCKS FOR TOOLS WITH CYLINDRICAL SHANK

MANDRINI IDRAULICI PER UTENSILI  
ATTACCO CILINDRICO 

HYDRO-DEHNSPANNFUTTER  
FÜR WERKZEUGE MIT ZYLINDERSCHAFT 

CONOS HIDRAULICOS PARA  
HERRAMIENTAS DE MANGO CILINDRICO 

MANDRINS HYDRO-EXPANSIBLES  
POUR OUTILS A QUEUE CYLINDRIQUE 

ГИДРАВЛИЧЕСКИЕ ПАТРОНЫ ДЛЯ  
ИНСТРУМЕНТА С ЦИЛИНДРИЧЕСКИМ  
ХВОСТОВИКОМ 

适用圆柱刀柄的液压膨胀夹头 

## OPERATING MANUAL FOR HIDRAULIC EXPANSION CHUCKS

MANUALE OPERATIVO PER L'UTILIZZO DEI MANDRINI IDRAULICI  
 MANUAL DE INSTRUCCIONES PARA EL USO DE LOS CONOS HIDRAULICOS  
 ИНСТРУКЦИЯ ПО ПРИМЕНЕНИЮ ГИДРАВЛИЧЕСКИХ ПАТРОНОВ

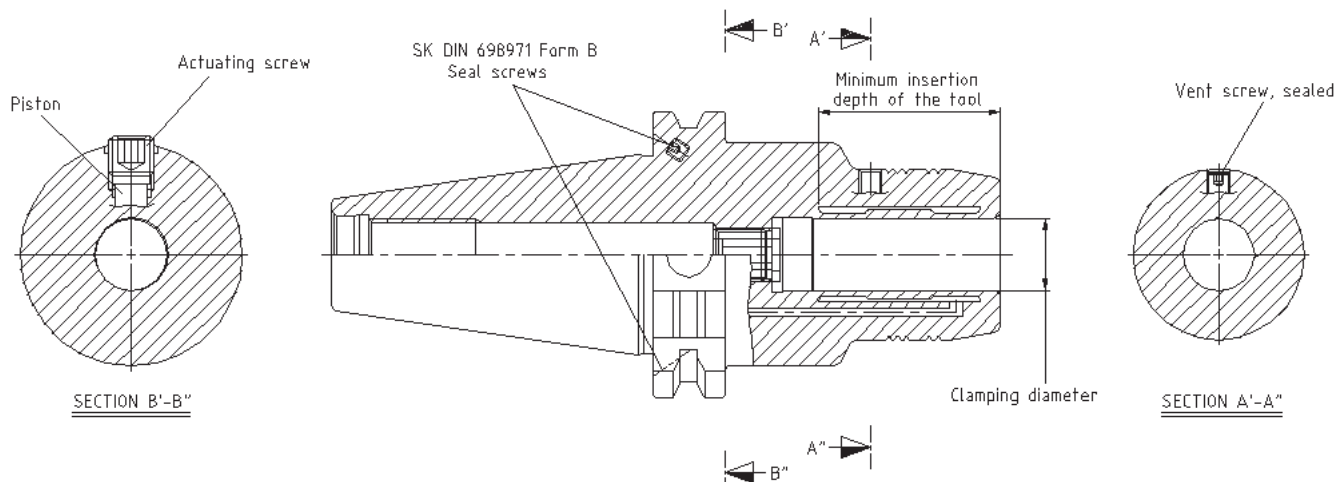

- Please follow our operating instruction carefully to save time and avoid problems:  
 Raccomandiamo di seguire le nostre istruzioni operative per risparmiare tempo ed evitare problemi:  
 Пожалуйста, следуйте нашим инструкциям, чтобы избежать проблем и потери времени:  
 Recomendamos seguir nuestras instrucciones de uso para ahorrar tiempo y evitar problemas:  
 Chart of technical data  
 Tabella delle informazioni tecniche  
 Tabla de datos técnicos:  
 Таблица с техническими характеристиками:

CHUCK DIAMETER (HC)	SHAFT CLAMPING	DEPENDENT ON THE MOUNTING SHANK (max RPM)	MINIMUM CLAMPING LENGTH (mm)	OPERATING TEMPERATURE	MAX COOLANT PRESSURE (bar)	MOMENT (Nm) 3
HC6	6 hb	40.000	27	20-50	80	8 Nm
HC8	8 hb	40.000	27	20-50	80	15 Nm
HC10	10 hb	40.000	32	20-50	80	30 Nm
HC12	12 hb	40.000	37	20-50	80	45 Nm
HC14	14 hb	40.000	37	20-50	80	75 Nm
HC16	16 hb	40.000	42	20-50	80	120 Nm
HC18	18 hb	40.000	42	20-50	80	170 Nm
HC20	20 hb	40.000	42	20-50	80	230 Nm
HC25	25 hb	25.000	48	20-50	80	300 Nm
HC32	32 hb	25.000	55	20-50	80	400 Nm

- Insert tools with totally cylindrical shank only and with tolerance h6
- Do not directly insert Weldon or Whistle-Notch attachments but only with reduction sleeve
- Never clamp the hydraulic chuck loosely without inserting the tool first
- During the clamping phase, screw the clamping screw until the end stop
- If the chuck is subject to long periods of use, open and clamp again the mounted tool before reusing it

- Inserire solo utensili con gambo totalmente cilindrico ed in tolleranza h6
- Non inserire direttamente attacchi Weldon o Whistle-Notch ma solo con bussola di riduzione
- Non chiudere mai il mandrino idraulico a vuoto senza inserire prima l'utensile
- In fase di chiusura mandare la vite di chiusura fino in battuta
- Se il mandrino è soggetto a lunghi periodi di utilizzo, prima di riutilizzarlo aprire e richiudere l'utensile montato

- Introducir solo herramientas con mango cilíndrico y tolerancia h6
- No introducir directamente las herramientas con mango Weldon o Whistle-Notch, utilizar casquillo reductor
- No accionar nunca el hidráulico sin meter la herramienta primero.
- Durante la fase de sujeción, apretar el tornillo de apriete hasta el tope
- Si el porta hidráulico ha estado con la herramienta apretado durante mucho tiempo, abrir y cerrar de nuevo para una correcta reutilización.

- Werkzeuge nur mit vollständig zylindrischem Schaft und mit Toleranz h6 einsetzen
- Keine Weldon- oder Whistle-Notch-Aufnahme direkt einsetzen, sondern nur mit einer Reduzierhülse
- Das Hydrospannfutter niemals locker klemmen, ohne vorher das Werkzeug einzusetzen

- Die Klemmschraube während der Spannphase bis zum Anschlag aufschrauben
- Wenn das Spannfutter für eine lange Zeit verwendet wird, das montierte Werkzeug aus- und wieder einspannen, bevor es wiederverwendet wird

- Insérer uniquement des outils avec une queue totalement cylindrique et avec tolérance h6
- Ne pas insérer directement les attachments Weldon ou Whistle-Notch mais uniquement avec une douille de réduction
- Ne jamais serrer le mandrin hydraulique à vide sans insérer l'outil au préalable
- Pendant la phase de serrage, visser la vis de serrage jusqu'à la butée
- Si le mandrin est sujet à de longues périodes d'utilisation, ouvrez et serrez à nouveau l'outil monté avant de le réutiliser

- Вставляются только инструменты с цилиндрическим хвостовиком и точностью h6
- Хвостовики weldon и whistle-notch вставляются только при помощи вспомогательных муфт
- Не закрывать гидравлический патрон без вставки инструмента
- При закрытии вкручивать винт до конца хода
- Если оправка подлежит длинным периодам использования, перед новым использованием необходимо заменить инструмент

- 仅限插入圆柱柄和公差h6的刀具
- 放入变径套之后才能插入侧固或者凹槽型附件
- 未插入刀具之前千万不要拧液压刀柄
- 在夹持过程中，拧紧螺丝到拧不动为止
- 刀柄在长时间使用过程中，每次使用前请先取出刀具，然后再插入刀柄重新拧紧。

# HYDRO-EXPANSION CHUCKS FOR TOOLS WITH CYLINDRICAL SHANK

## HYDRO-EXPANSION CHUCKS FOR TOOLS WITH CYLINDRICAL SHANK

HYDRO-DEHNSTANNFUTTER FÜR WERKZEUGE MIT ZYLINDERSCHAFT  
 CONOS HIDRAULICOS PARA HERRAMIENTAS CON MANGO CILINDRICO  
 ГИДРАВЛИЧЕСКИЕ ПАТРОНЫ ДЛЯ ИНСТРУМЕНТА  
 С ЦИЛИНДРИЧЕСКИМ ХВОСТОВИКОМ

MANDRINI IDRAULICI PER UTENSILI ATTACCO CILINDRICO  
 MANDRINS HYDRO-EXPANSIBLES POUR OUTILS  
 A QUEUE CYLINDRIQUE  
 适用圆柱刀柄的液压膨胀夹头

### MAS 403/BT AD

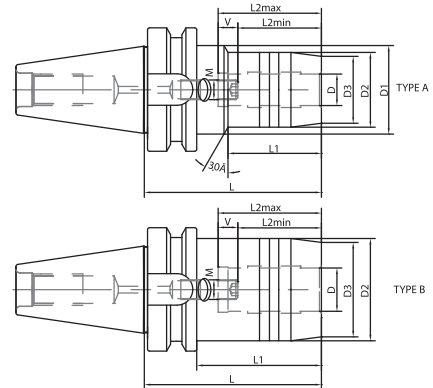
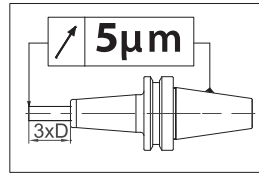

	CODE N.	DESCRIPTION	ISO	D	D1	D2	D3	L	L1	L2 min	L2 max	V	M	TYPE	G2,5 25000	
BT 30	252-11467	BT30-HC3-70	30	3	45	24	21	70	30	-	24	-	-	A	•	
	252-11468	BT30-HC4-70	30	4	45	25	22	70	30	-	28	-	-	A	•	
	252-11470	BT30-HC6-70	30	6	45	28	25	70	28	27,5	37,5	10	M5x0,8	A	•	
	252-11471	BT30-HC8-70	30	8	45	30	27	70	28	27,5	37,5	10	M6x1	A	•	
	252-11472	BT30-HC10-75	30	10	45	32	29	75	38	32,5	42,5	10	M6x1	A	•	
	252-11473	BT30-HC12-75	30	12	45	34	31	75	36	37,5	47,5	10	M6x1	A	•	
	252-11474	BT30-HC14-85	30	14	45	36	33	85	44	37,5	47,5	10	M6x1	A	•	
	252-11419	BT30-HC16-90	30	16	45	38	35	90	48	42,5	52,5	10	M8x1	A	•	
	252-11420	BT30-HC18-90	30	18	45	41	38	90	48	42,5	52,5	10	M8x1	A	•	
	*	252-11442	BT30-G20CS-85	30	20	-	44	40	85	63	42,5	52,5	10	M8x1	B	•
	252-11421	BT30-HC20-90	30	20	-	43	40	90	68	42,5	52,5	10	M8x1	B	•	
BT 40	252-11422	BT40-HC6-90	40	6	50	28	25	90	44	27,5	37,5	10	M5x0,8	A	•	
	252-11423	BT40-HC8-90	40	8	50	30	27	90	39	27,5	37,5	10	M6x1	A	•	
	252-11424	BT40-HC10-90	40	10	50	32	29	90	44	32,5	42,5	10	M6x1	A	•	
	252-11425	BT40-HC12-90	40	12	50	34	31	90	44	37,5	47,5	10	M6x1	A	•	
	252-11426	BT40-HC14-90	40	14	50	36	33	90	44	37,5	47,5	10	M6x1	A	•	
	252-11427	BT40-HC16-90	40	16	50	38	35	90	48	42,5	52,5	10	M8x1	A	•	
	252-11428	BT40-HC18-90	40	18	50	41	38	90	48	42,5	52,5	10	M8x1	A	•	
	*	252-11443	BT40-G20CS-72,5	40	20	-	49,5	40	72,5	45,5	42,5	52,5	10	M8x1	B	•
		252-11429	BT40-HC20-90	40	20	50	43	40	90	48	42,5	52,5	10	M8x1	A	•
		252-11482	BT40-HC20-140	40	20	50	43	40	140	48	42,5	52,5	10	M8x1	A	•
	252-11483	BT40-HC25-100	40	25	-	57	53	100	73	51	61	10	M16x1	B	•	
	252-11485	BT40-HC32-105	40	32	-	63	58	105	-	55	65	10	M16x1	B	•	

	CODE N.	DESCRIPTION	ISO	D	D1	D2	D3	L	L1	L2 min	L2 max	V	M	TYPE	G2,5 25000
	252-11433	BT50-HC8-90	50	8	50	30	27	90	32	27,5	37,5	10	M6x1	A	•
	252-11434	BT50-HC10-90	50	10	50	32	29	90	32	32,5	42,5	10	M6x1	A	•
	252-11435	BT50-HC12-90	50	12	50	34	31	90	32	37,5	47,5	10	M6x1	A	•
	252-11436	BT50-HC14-90	50	14	50	36	33	90	32	37,5	47,5	10	M6x1	A	•
	252-11437	BT50-HC16-90	50	16	50	38	35	90	32	42,5	52,5	10	M8x1	A	•
	252-11438	BT50-HC18-90	50	18	50	41	38	90	32	42,5	52,5	10	M8x1	A	•
*	252-11439	BT50-HC20-90	50	20	50	43	40	90	32	42,5	52,5	10	M8x1	A	•
	252-11494	BT50-HC20-140	50	20	50	43	40	140	48	42,5	52,5	10	M8x1	A	•
	252-11495	BT50-HC25-105	50	25	-	57	53	105	86	51	61	10	M16x1	A	•
	252-11496	BT50-HC25-150	50	25	-	57	53	150	112	51	61	10	M16x1	B	•
	252-11444	BT50-G32CS-90	50	32	-	72	60	90	52	55	65	10	M16x1	B	•
	252-11497	BT50-HC32-115	50	32	-	63	58	115	77	55	65	10	M16x1	B	•

### \* COMPACT VERSION

Accessories  
 Accessori  
 Zubehör  
 Accesorios  
 Accessoires  
 Принадлежности  
 零件



# HYDRO-EXPANSION CHUCKS FOR TOOLS WITH CYLINDRICAL SHANK

## HYDRO-EXPANSION CHUCKS FOR TOOLS WITH CYLINDRICAL SHANK

HYDRO-DEHNSPANNFUTTER FÜR WERKZEUGE MIT ZYLINDERSCHAFT  
CONOS HIDRAULICOS PARA HERRAMIENTAS CON MANGO CILINDRICO  
ГИДРАВЛИЧЕСКИЕ ПАТРОНЫ ДЛЯ ИНСТРУМЕНТА  
С ЦИЛИНДРИЧЕСКИМ ХВОСТОВИКОМ

MANDRINI IDRAULICI PER UTENSILI ATTACCO CILINDRICO  
MANDRINS HYDRO-EXPANSIBLES POUR OUTILS  
A QUEUE CYLINDRIQUE  
适用圆柱刀柄的液压膨胀夹头

**DIN69871 AD**

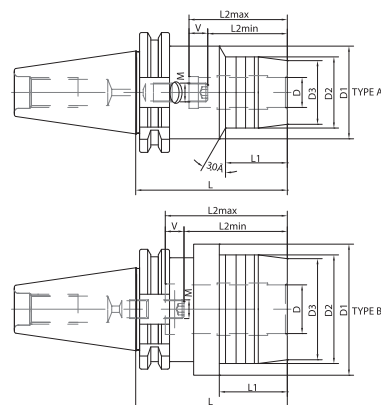
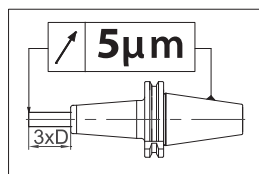

CODE N.	DESCRIPTION	ISO	D	D1	D2	D3	L	L1	L2 min	L2 max	V	M	TYPE	G2,5 25000
252-11305	TC40-HC6-80,5	40	6	50	28	25	80,5	44	27,5	37,5	10	M5x0,8	A	•
252-11307	TC40-HC8-80,5	40	8	50	30	27	80,5	44	27,5	37,5	10	M6x1	A	•
252-11308	TC40-HC8-110	40	8	50	30	27	110	44	27,5	37,5	10	M6x1	A	•
252-11309	TC40-HC10-80,5	40	10	50	32	29	80,5	44	32,5	42,5	10	M6x1	A	•
252-11310	TC40-HC10-110	40	10	50	32	29	110	44	32,5	42,5	10	M6x1	A	•
252-11311	TC40-HC12-80,5	40	12	50	34	31	80,5	44	37,5	47,5	10	M6x1	A	•
252-11312	TC40-HC12-110	40	12	50	34	31	110	44	37,5	47,5	10	M6x1	A	•
252-11327	TC40-HC14-80,5	40	14	50	36	33	80,5	44	37,5	47,5	10	M6x1	A	•
252-11313	TC40-HC16-80,5	40	16	50	38	35	80,5	48	42,5	52,5	10	M8x1	A	•
252-11314	TC40-HC16-110	40	16	50	38	35	110	48	42,5	52,5	10	M8x1	A	•
252-11328	TC40-HC18-80,5	40	18	50	41	38	80,5	30	42,5	52,5	10	M8x1	A	•
*252-11325	TC40-G20CS-64,5	40	20	-	49,5	40	64,5	45,5	42,5	52,5	10	M8x1	A	•
252-11315	TC40-HC20-80,5	40	20	50	43	40	80,5	48	42,5	52,5	10	M8x1	A	•
252-11316	TC40-HC20-110	40	20	50	43	40	110	48	42,5	52,5	10	M8x1	A	•
252-11317	TC40-HC25-80,5	40	25	66	57	53	80,5	26	51	61	10	M16x1	B	•
252-11318	TC40-HC32-80,5	40	32	80	63	60	80,5	26	55	65	10	M16x1	B	•

CODE N.	DESCRIPTION	ISO	D	D1	D2	D3	L	L1	L2 min	L2 max	V	M	TYPE	G2,5 25000
252-11348	TC50-HC6-90	50	6	50	28	25	90	44	27,5	37,5	10	M5x0,8	A	•
252-11350	TC50-HC8-90	50	8	50	30	27	90	44	27,5	37,5	10	M6x1	A	•
252-11352	TC50-HC10-90	50	10	50	32	29	90	44	32,5	42,5	10	M6x1	A	•
252-11354	TC50-HC12-90	50	12	50	34	31	90	44	37,5	47,5	10	M6x1	A	•
252-11356	TC50-HC14-90	50	14	50	36	33	90	47	37,5	47,5	10	M6x1	A	•
252-11358	TC50-HC16-90	50	16	50	38	35	90	48	42,5	52,5	10	M8x1	A	•
252-11360	TC50-HC18-90	50	18	50	41	38	90	48	42,5	52,5	10	M8x1	A	•
252-11362	TC50-HC20-90	50	20	50	43	40	90	48	42,5	52,5	10	M8x1	A	•
252-11363	TC50-HC20-140	50	20	50	43	40	140	48	42,5	52,5	10	M8x1	A	•
252-11364	TC50-HC25-105	50	25	-	57	53	105	86	51	61	10	M16x1	B	•
*252-11326	TC50-G32CS-81	50	32	-	72	60	81	62	55	65	10	M16x1	B	•
252-11366	TC50-HC32-115	50	32	-	63	58	115	96	55	65	10	M16x1	B	•
252-11367	TC50-HC32-140	50	32	-	63	58	140	121	55	65	10	M16x1	B	•

**\* COMPACT VERSION**

Accessories  
Accessori  
Zubehör  
Accesorios  
Accessoires  
Принадлежности  
零件



# HYDRO-EXPANSION CHUCKS FOR TOOLS WITH CYLINDRICAL SHANK

## HYDRO-EXPANSION CHUCKS FOR TOOLS WITH CYLINDRICAL SHANK

HYDRO-DEHNSPANNFUTTER FÜR WERKZEUGE MIT ZYLINDERSCHAFT  
 CONOS HIDRAULICOS PARA HERRAMIENTAS CON MANGO CILINDRICO  
 ГИДРАВЛИЧЕСКИЕ ПАТРОНЫ ДЛЯ ИНСТРУМЕНТА  
 С ЦИЛИНДРИЧЕСКИМ ХВОСТОВИКОМ

MANDRINI IDRAULICI PER UTENSILI ATTACCO CILINDRICO  
 MANDRINS HYDRO-EXPANSIBLES POUR OUTILS  
 A QUEUE CYLINDRIQUE  
 适用圆柱刀柄的液压膨胀夹头

**DIN69893 A**

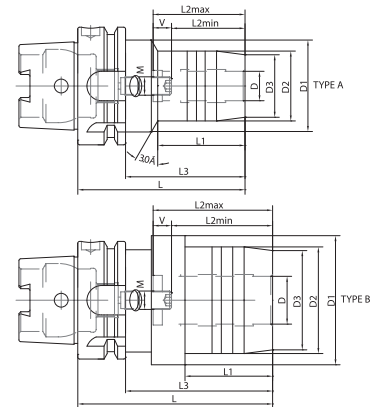
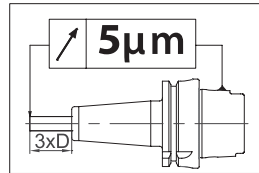

	CODE N.	DESCRIPTION	HSK	D	D1	D2	D3	L	L1	L3	L2 min	L2 max	V	M	TYPE	G2,5 25000
HSK 50	252-11759	HSK50A-HC6-70	50	6	40	28	25	70	28	44	27,5	37,5	10	M5x0,8	A	•
	252-11760	HSK50A-HC8-70	50	8	40	30	27	70	28	44	27,5	37,5	10	M6x1	A	•
	252-11761	HSK50A-HC10-80	50	10	40	32	29	80	34	54	32,5	42,5	10	M6x1	A	•
	252-11762	HSK50A-HC12-85	50	12	40	34	31	85	44	59	37,5	47,5	10	M6x1	A	•
	252-11764	HSK50A-HC16-90	50	16	60	38	35	90	30	64	42,5	52,5	10	M6x1	B	•
	252-11765	HSK50A-HC18-90	50	18	-	41	38	90	-	64	42,5	52,5	10	M6x1	A	•
	252-11766	HSK50A-HC20-90	50	20	-	42	40	90	-	64	42,5	52,5	10	M6x1	A	•
HSK 63	252-11737	HSK63A-HC6-70	63	6	50	28	25	70	24	44	27,5	37,5	10	M5x0,8	A	•
	252-11738	HSK63A-HC8-70	63	8	50	30	27	70	24	44	27,5	37,5	10	M6x1	A	•
	252-11739	HSK63A-HC10-80	63	10	50	32	29	80	35	54	32,5	42,5	10	M6x1	A	•
	252-11740	HSK63A-HC12-85	63	12	50	34	31	85	40	59	37,5	47,5	10	M6x1	A	•
	252-11741	HSK63A-HC14-85	63	14	50	36	33	85	40	59	37,5	47,5	10	M6x1	A	•
	252-11742	HSK63A-HC16-90	63	16	50	38	35	90	46	64	42,5	52,5	10	M8x1	A	•
	*252-11744	HSK63A-HC20-90	63	20	50	43	40	90	48	64	42,5	52,5	10	M8x1	A	•
	252-21718	HSK63A-HC20-150	63	20	50	43	40	150	108	124	42,5	52,5	10	M8x1	-	•
	252-21719	HSK63A-HC20-200	63	20	50	43	40	200	108	174	42,5	52,5	10	M8x1	-	•
	252-11745	HSK63A-HC25-120	63	25	63	57	53	120	59	94	51	61	10	M16x1	B	•
252-11746	HSK63A-HC32-125	63	32	75	63	58	125	63	99	55	65	10	M16x1	B	•	
HSK 100	252-11767	HSK100A-HC6-75	100	6	54	28	25	75	26	46	27,5	37,5	10	M5x0,8	A	•
	252-11768	HSK100A-HC8-75	100	8	54	30	27	75	26	46	27,5	37,5	10	M6x1	A	•
	252-11769	HSK100A-HC10-90	100	10	50	32	29	90	42	61	32,5	42,5	10	M6x1	A	•
	252-11770	HSK100A-HC12-95	100	12	50	34	31	95	47	66	37,5	47,5	10	M6x1	A	•
	252-11771	HSK100A-HC14-95	100	14	50	36	33	95	47	66	37,5	47,5	10	M6x1	A	•
	252-11772	HSK100A-HC16-100	100	16	50	38	35	100	53	71	42,5	52,5	10	M8x1	A	•
	252-11774	HSK100A-HC20-105	100	20	50	43	40	105	59	76	42,5	52,5	10	M8x1	A	•
	252-11775	HSK100A-HC25-110	100	25	63	57	53	110	62	81	51	61	10	M8x1	A	•
	252-11776	HSK100A-HC32-110	100	32	75	63	58	110	62	81	55	65	10	M8x1	A	•

**\* COMPACT VERSION**

Accessories  
 Accessori  
 Zubehör  
 Accesorios  
 Accessoires  
 Принадлежности  
 零件



05

KINTEK®

## WATERTIGHT COLLETS

SPANNZANGEN ABGEDICHTET PINZE A TENUTA STAGNA  
 PINZAS ESTANCAS PINCES ETANCHES  
 ЦАНГИ ДЛЯ ВНУТРЕННЕЙ ПОДАЧИ СОЖ 水密性 夹头

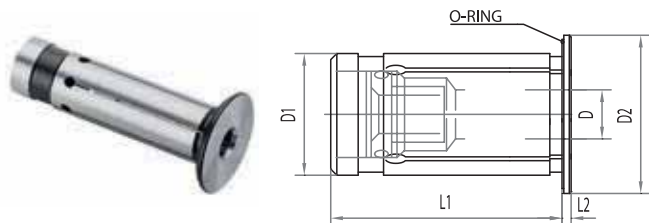

TYPE	D1	D2	L1	L2	D nole size
OGX12D...	12	21	45	2	3;4;5;6;8;
OGX20D...	20	29	50.5	2	3;4;5;6;8;10;12;16
OGX32D...	32	39	60.5	3	6;8;10;12;16;20;25

OGX TYPE IS 100% COOLANT WATERPROOF OVER TO 80 BAR.  
 PLEASE INSERT THE REDUCTION SLEEVE INTO THE CHUCK AFTER INSERT  
 A CUTTING TOOL INTO THE REDUCTION SLEEVE.

## COLLETS FOR HYDRAULIC CHUCKS

ABGEDICHTETE SPANNZANGEN FÜR HYDRODEHNSPANNFUTTER PINZE PER MANDRINI IDRAULICI  
 PINZAS PARA CONOS HIDRAULICOS PINCES POUR MANDRINS HYDRAULIQUES  
 ЦАНГИ ДЛЯ ГИДРАВЛИЧЕСКИХ ПАТРОНОВ 液压卡盘夹头

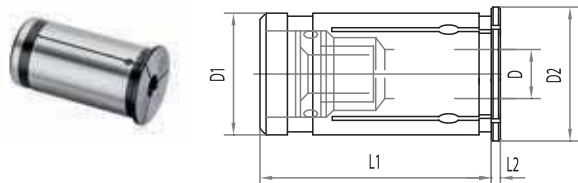

TYPE	D1	D2	L1	L2	D nole size
GX12D...	12	16	44,5	2	3;4;5;6;8;
GX20D...	20	24	50.5	2	3;4;5;6;8;10;12;14;16
GX32D...	32	36	60.5	3	6;8;10;12;14;16;18;20;25

## HYDRAULIC KIT

HYDRO-DEHNSPANNFUTTERSATZ KIT IDRAULICO  
 SET HIDRAULICO JEUX HYDRAULIQUE  
 НАБОРЫ ГИДРОПЛАСТОВЫХ ПАТРОНОВ С ЦАНГАМИ 液压组套

**Kit Box:** 1 hydraulic chuck + 1 collets kit + 1 wrench

**Cassetta Corredo:** 1 mandrino "idraulico" + 1 serie pinze + 1 chiave

**Ausstattungskasten:** 1 Hydro-Dehnspannfutter + 1 Spannzangensatz + 1 Spannschlüssel

**Contenido del set:** 1 Cono hidraulico + 1 Juego de pinzas + 1 Llave

**Boîte d'équipement:** 1 mandrin hydraulique + 1 jeux de pince + 1 clé

**Набор:** 1 гидропластовый патрон + 1 ключ + 1 набор втулок  
 组套箱: 1个液压夹头 + 1个夹头组套 + 1个扳手



	CODICE ORDINAZIONE ORDER CODE	COMPOSIZIONE COMPOSITION
ISO 40	KIT BT30 G20	N°1 BT30 H85 G20-WO + n°5 pinze GX20: Ø6,8,10,12,16
	KIT BT40 G20	N°1 BT40 H72,5 G20-WO + n°5 pinze GX20: Ø6,8,10,12,16
	KIT BT40 G32	N°1 BT40 H105 G32-WO + n°7 pinze GX32: Ø10,12,14,16,18,20,25
	KIT TC40 G20	N°1 TC40 H64,5 G20-WO + n°5 pinze GX20: Ø6,8,10,12,16
	KIT TC40 G32	N°1 TC40 H80,5 G32-WO + n°7 pinze GX32: Ø10,12,14,16,18,20,25
ISO 50	KIT BT50 G20	N°1 BT50 H90 G20-WO + n°5 pinze GX20: Ø6,8,10,12,16
	KIT BT50 G32	N°1 BT50 H90 G32-WO + n°7 pinze GX32: Ø10,12,14,16,18,20,25
	KIT TC50 G20	N°1 TC50 H90 G20-WO + n°5 pinze GX20: Ø6,8,10,12,16
	KIT TC50 G32	N°1 TC50 H81 G32-WO + n°7 pinze GX32: Ø10,12,14,16,18,20,25
	KIT HSK63A G20	N°1 HSK63A H90 G20 + n°5 pinze GX20: Ø6,8,10,12,16
	KIT HSK63A G32	N°1 HSK63A H125 G32 + n°7 pinze GX32: Ø10,12,14,16,18,20,25
	KIT HSK100 G20	N°1 HSK100 H105 G20 + n°5 pinze GX20: Ø6,8,10,12,16
	KIT HSK100 G32	N°1 HSK100 H110 G32 + n°7 pinze GX32: Ø10,12,14,16,18,20,25

# HYDRO POWER LINE



## A new technology in the hydraulic chucking for high precision and excellent surfaces !

Thanks to a modern mixture of conventional steel body and sintered-processed material, we introduce you to the new **HYDRO POWER LINE** of chucks.

Main advantages:

- Thermal performances till 120 ° C and the clamping force increases under the influence of temperature.
- Suitable solution for Drilling, Reaming and also Milling!
- Ideal for machining in contour-critical areas, slim 3° version as for shrink
- High torque transmission
- Long tool life and easy tool change
- Exceptional radial runout <3µ
- No investment for additional equipment , no risk of burning for operator or damaging the holder because of wrong cooling.



## Eine neue Technologie von hydraulischen Spannfütern für hohe Präzision und hervorragende Oberflächen

Dank einer modernen Mischung vom konventionellen Stahl-Grundkörper und gesintertes Material, präsentieren wir die neue **HYDRO POWER LINE** Futter.

Einige Plus:

- Thermische Stabilität bis 120° , die Vorspannkraft steigt unter Einfluss der Temperatur.
- Richtige Lösung zum Bohren, Reiben und auch Fräsen!
- Ideal für die Bearbeitung in konturkritischen Bereichen, Slim 3° Ausführung wie bei Schrumpffutter
- Hohe Vorspannkraft
- Längere Standzeiten, einfacherer und schnellerer Werkzeugwechsel
- Außergewöhnlicher Rundlauf <3µ
- Keine Investition für zusätzliche Ausrüstung, kein Verbrennungsrisiko für den Bediener und keine Beschädigung des Futter wegen falscher Kühlung



## Новая технология гидравлических патронов: высокая точность и отличная поверхность!

Новая технология гидравлических патронов: высокая точность и отличная поверхность! Благодаря современной обработке стандартного стального корпуса и материала для спекания, мы представляем Вам новый вариант патронов **HYDRO POWER LINE**.

Основные преимущества:

- Температурные характеристики до 120 ° C и зажимное усилие увеличивается под воздействием температуры.
- Отлично подходит для сверления, развертывания и фрезерования!
- Идеально подходит для обработки в критических областях, тонкая версия 3 ° как у термозажимных патронов
- Передача с высоким крутящим моментом
- Длительный срок службы и замены инструмента
- Радиальное биение <3µ
- Отсутствие риска ожога для оператора и повреждения держателя из-за охлаждения при отжиме.



## Una nueva tecnología de conos hidráulicos para una alta precisión y mecanizado excelentes!

Gracias a la moderna combinación entre el cuerpo de acero y el proceso de sinterizado, os presentemos nuestra nueva línea de portas

### HYDRO POWER LINE.

Principales ventajas:

- Estabilidad térmica hasta los 120° C. La fuerza de apriete incrementa bajo la influencia de la temperatura.
- Solución adecuada para taladrar, escariar y también fresar!
- Ideal para mecanizado en áreas de contornos críticos, versión 3° Slim como para los térmicos.
- Elevada fuerza de apriete
- Vida de la herramienta más larga y cambio herramienta más rápido y sencillo
- Extraordinaria concentricidad <3µ
- No requiere de inversión adicional, sin riesgo de quemaduras para el operador y de daños del cono debido a un enfriamiento incorrecto



## Una nuova tecnologia di mandrini idraulici per un'elevata precisione e lavorazioni eccellenti

Grazie alla moderna unione tra base mandrino in acciaio e parte in materiale sinterizzato, vi presentiamo la nostra nuova linea di mandrini **HYDRO POWER LINE**

Alcuni dei vantaggi:

- Stabilità termica fino a 120° C. La forza di serraggio aumenta sotto l'influenza della temperatura.
- Giusta soluzione per forare, alesare e anche per fresare!
- Ideale per lavorazioni in aree dai contorni critici, Versione 3° Slim come nel calettamento
- Elevata forza di serraggio
- Vita dell'utensile più lunga e cambio utensile più veloce e semplice
- Eccezionale runout <3µ
- Nessun investimento per attrezzature aggiuntive, nessun rischio di bruciatura per l'operatore e di danneggiamento mandrino a causa di un raffreddamento errato.



## Une nouvelle technologie de mandrins hydro-expansibles pour une haute précision et pour un usinage excellent!

Grâce au moderne mélange entre la base en acier du mandrin et la partie en matériel fritté, nous vous présentons la nouvelle **LIGNE HYDRO POWER** de mandrins.

Principaux avantages:

- Stabilité thermique jusqu'à 120 ° C. La force de serrage augmente sous l'influence de la température.
- Solution appropriée pour le perçage, l'alesage et le fraisage!
- Idéal pour l'usinage dans les zones aux contours critiques, version 3 ° Slim comme pour le frettage
- Haute force de serrage
- Vie de l'outil plus longue et changement d'outil plus simple et plus rapide
- Concentricité exceptionnelle <3 µ
- Aucun investissement pour équipement supplémentaire, aucun risque de brûlure pour l'opérateur et aucun endommagement du mandrin à cause d'un refroidissement incorrect.



## 高精度和杰出触面的液压刀柄新技术！

得益于特殊内部钢体构造和经过特殊烧结加工的材料完美结合，我们推出新的强力液压刀柄

主要优势:

- 高达120° C的完美热表现，夹持力在温度影响下增强
- 适合钻，铰，铣加工！
- 尤其适合表面条件严峻的区域，在适合3°热缩刀柄加工的场合亦能胜任！
- 超高力矩传输
- 超长使用期限和超筒装配工序
- 杰出的径向精度 <3µ
- 无需投资额外设备，无烫伤风险及因不当冷却导致的刀柄损坏风险。



# HYDRO-EXPANSION CHUCKS FOR TOOLS WITH CYLINDRICAL SHANK

## HYDRO-EXPANSION CHUCKS FOR TOOLS WITH CYLINDRICAL SHANK

HYDRO-DEHNSPANNFUTTER FÜR WERKZEUGE MIT ZYLINDERSCHAFT  
CONOS HIDRAULICOS PARA HERRAMIENTAS CON MANGO CILINDRICO  
ГИДРАВЛИЧЕСКИЕ ПАТРОНЫ ДЛЯ ИНСТРУМЕНТА  
С ЦИЛИНДРИЧЕСКИМ ХВОСТОВИКОВ

MANDRINI IDRAULICI PER UTENSILI ATTACCO CILINDRICO  
MANDRINS HYDRO-EXPANSIBLES POUR OUTILS  
A QUEUE CYLINDRIQUE  
适用圆柱刀柄的液压膨胀夹头

**DIN69871**

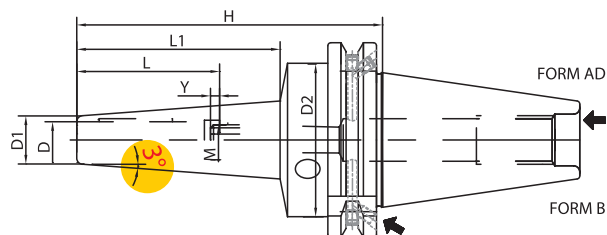
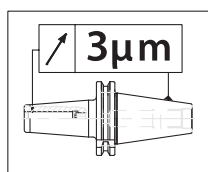

### 3° PROGRAMME HYDRO SLIM LINE

CODE N.	DESCRIPTION	D	H	L	Ymax	D1	D2	L1	M	SW	G2,5 25000
252-11368	TC40H120D03-HPL	3	120	28	16	9	49,5	80	M2,5	1,3	•
252-11369	TC40H120D04-HPL	4	120	28	12	10	49,5	80	M2,5	1,3	•
252-11370	TC40H120D05-HPL	5	120	28	8	11	49,5	80	M2,5	1,3	•
252-11371	TC40H120D06-HPL	6	120	37	10	12	49,5	80	M5	2,5	•
252-11379	TC40H160D06-HPL	6	160	37	10	16	49,5	119	M5	2,5	•
252-11380	TC40H200D06-HPL	6	200	37	10	16	49,5	161	M5	2,5	•
252-11372	TC40H120D08-HPL	8	120	37	10	14	49,5	80	M6	3	•
252-11381	TC40H160D08-HPL	8	160	37	10	18	49,5	120	M6	3	•
252-11373	TC40H120D10-HPL	10	120	41	10	16	49,5	81	M8x1	3	•
252-11383	TC40H160D10-HPL	10	160	41	10	20	49,5	121	M8x1	3	•
252-11374	TC40H120D12-HPL	12	120	46	10	18	49,5	82	M10x1	5	•
252-11385	TC40H160D12-HPL	12	160	46	10	22	49,5	122	M10x1	5	•
252-11376	TC40H120D16-HPL	16	120	49	10	24	49,5	79	M12x1	5	•
252-11378	TC40H120D20-HPL	20	120	51	10	28	49,5	80	M16x1	5	•

**MAS BT**

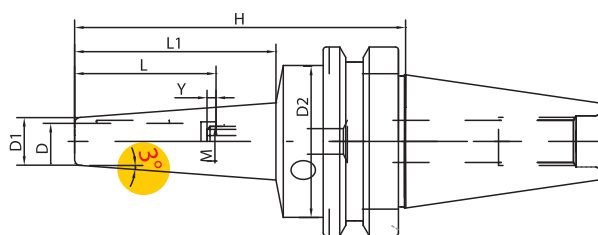
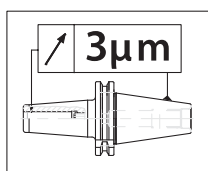

### 3° PROGRAMME HYDRO SLIM LINE

CODE N.	DESCRIPTION	D	H	L	Ymax	D1	D2	L1	M	SW	G2,5 25000
252-21401	BT40H120D03-HPL	3	120	28	16	9	49,5	72	M2,5	1,3	•
252-21402	BT40H120D04-HPL	4	120	28	12	10	49,5	72	M2,5	1,3	•
252-21404	BT40H120D06-HPL	6	120	37	10	12	49,5	72	M5	2,5	•
252-21412	BT40H160D06-HPL	6	160	37	10	16	49,5	111	M5	2,5	•
252-21405	BT40H120D08-HPL	8	120	37	10	14	49,5	72	M6	3	•
252-21414	BT40H160D08-HPL	8	160	37	10	18	49,5	112	M6	3	•
252-21406	BT40H120D10-HPL	10	120	41	10	16	49,5	73	M8x1	3	•
252-21416	BT40H160D10-HPL	10	160	41	10	20	49,5	113	M8x1	3	•
252-21407	BT40H120D12-HPL	12	120	46	10	18	49,5	74	M10x1	5	•
252-21418	BT40H160D12-HPL	12	160	46	10	22	49,5	114	M10x1	5	•
252-21409	BT40H120D16-HPL	16	120	49	10	24	49,5	71	M12x1	5	•
252-21411	BT40H120D20-HPL	20	120	51	10	28	49,5	72	M16x1	5	•

## HYDRO-EXPANSION CHUCKS FOR TOOLS WITH CYLINDRICAL SHANK

HYDRO-DEHNSPANNFUTTER FÜR WERKZEUGE MIT ZYLINDERSCHAFT  
 CONOS HIDRAULICOS PARA HERRAMIENTAS CON MANGO CILINDRICO  
 ГИДРАВЛИЧЕСКИЕ ПАТРОНЫ ДЛЯ ИНСТРУМЕНТА  
 С ЦИЛИНДРИЧЕСКИМ ХВОСТОВИКОМ

MANDRINI IDRAULICI PER UTENSILI ATTACCO CILINDRICO  
 MANDRINS HYDRO-EXPANSIBLES POUR OUTILS  
 A QUEUE CYLINDRIQUE  
 适用圆柱刀柄的液压膨胀夹头

**DIN 69893A**

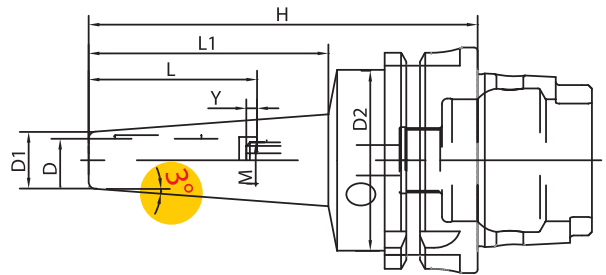
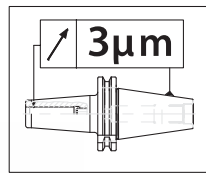

### 3° PROGRAMME HYDRO SLIM LINE

CODE N.	DESCRIPTION	D	H	L	Ymax	D1	D2	L1	M	SW	G2,5 25000
252-21720	HSK63AH120D03-HPL	3	120	28	16	9	50	73	M2,5	1,3	•
252-21721	HSK63AH120D04-HPL	4	120	28	12	10	50	73	M2,5	1,3	•
252-21723	HSK63AH120D06-HPL	6	120	37	10	12	50	73	M5	2,5	•
252-21738	HSK63AH160D06-HPL	6	160	37	10	16	50	111	M5	2,5	•
252-21724	HSK63AH120D08-HPL	8	120	37	10	14	50	74	M6	3	•
252-21754	HSK63AH160D08-HPL	8	160	37	10	18	50	111	M6	3	•
252-21756	HSK63AH120D09-HPL	9	120	37	10	15	50	74	M6	3	•
252-21725	HSK63AH120D10-HPL	10	120	41	10	16	50	74	M8x1	3	•
252-21757	HSK63AH160D10-HPL	10	160	41	10	20	50	113	M8x1	3	•
252-21726	HSK63AH120D12-HPL	12	120	46	10	18	50	75	M10x1	5	•
252-21760	HSK63AH160D12-HPL	12	160	46	10	22	50	113	M10x1	5	•
252-21727	HSK63AH120D14-HPL	14	120	46	10	22	50	71	M10x1	5	•
252-21728	HSK63AH120D16-HPL	16	120	49	10	24	50	72	M12x1	5	•
252-21729	HSK63AH120D18-HPL	18	120	49	10	26	50	72	M12x1	5	•
252-21730	HSK63AH120D20-HPL	20	120	51	10	28	50	72	M16x1	5	•

